



Standard Practice for Heat Fusion Joining of Polyethylene Pipe and Fittings¹

This standard is issued under the fixed designation F2620; the number immediately following the designation indicates the year of original adoption or, in the case of revision, the year of last revision. A number in parentheses indicates the year of last reapproval. A superscript epsilon (ϵ) indicates an editorial change since the last revision or reapproval.

1. Scope*

1.1 This practice describes procedures for making joints with polyethylene (PE) pipe and fittings by means of heat fusion joining in, but not limited to, a field environment. Other suitable heat fusion joining procedures are available from various sources including pipe and fitting manufacturers. This standard does not purport to address all possible heat fusion joining procedures, or to preclude the use of qualified procedures developed by other parties that have been proved to produce reliable heat fusion joints.

1.2 The parameters and procedures are applicable only to joining polyethylene pipe and fittings of related polymer chemistry. They are intended for PE fuel gas pipe per Specification **D2513** and PE potable water, sewer and industrial pipe manufactured per Specification **F714**, Specification **D3035**, and AWWA C901 and C906. Consult with the pipe manufacturers to make sure they approve this procedure for the pipe to be joined (see **Appendix X1**).

NOTE 1—Information about polyethylene pipe and fittings that have related polymer chemistry is presented in Plastics Pipe Institute (PPI) TR-33 and TR-41.

1.3 Parts that are within the dimensional tolerances given in present ASTM specifications are required to produce sound joints between polyethylene pipe and fittings when using the joining techniques described in this practice.

1.4 The values stated in inch-pound units are to be regarded as standard. The values given in parentheses are mathematical conversions to SI units that are provided for information only and are not considered standard.

1.5 The text of this practice references notes, footnotes, and appendixes which provide explanatory material. These notes and footnotes (excluding those in tables and figures) shall not be considered as requirements of the practice.

1.6 *This standard does not purport to address all of the safety concerns, if any, associated with its use. It is the responsibility of the user of this standard to establish appro-*

priate safety and health practices and determine the applicability of regulatory limitations prior to use.

2. Referenced Documents

2.1 ASTM Standards:²

D2513 Specification for Polyethylene (PE) Gas Pressure Pipe, Tubing, and Fittings

D3035 Specification for Polyethylene (PE) Plastic Pipe (DR-PR) Based on Controlled Outside Diameter

F714 Specification for Polyethylene (PE) Plastic Pipe (DR-PR) Based on Outside Diameter

F1056 Specification for Socket Fusion Tools for Use in Socket Fusion Joining Polyethylene Pipe or Tubing and Fittings

2.2 PPI Documents:

TR-33 Generic Butt Fusion Joining Procedure for Field Joining of Polyethylene³

TR-41 Generic Saddle Fusion Joining Procedure for Polyethylene Gas Piping³

2.3 AWWA Documents:

AWWA C901 Standard for Polyethylene (PE) Pressure Pipe and Tubing, ½ in. (13 mm) through 3 in. (76 mm), for Water Service⁴

AWWA C906 Standard for Polyethylene (PE) Pressure Pipe and Fittings, 4 in. (100 mm) through 63 in. (1575 mm), for Water Distribution and Transmission⁴

3. Summary of Practice

3.1 The principle of heat fusion joining of polyethylene (PE) pipe is to heat two prepared surfaces to a designated temperature, then fuse them together by application of a sufficient force. This force causes the melted materials to flow and mix, thereby resulting in fusion.

3.2 The heat-fusion procedures covered in this practice are socket fusion, butt fusion, and saddle fusion.

² For referenced ASTM standards, visit the ASTM website, www.astm.org, or contact ASTM Customer Service at service@astm.org. For *Annual Book of ASTM Standards* volume information, refer to the standard's Document Summary page on the ASTM website.

³ Available from Plastics Pipe Institute (PPI), 105 Decker Court, Suite 825, Irving, TX 75062, <http://www.plasticpipe.org>.

⁴ Available from American Water Works Association (AWWA), 6666 W. Quincy Ave., Denver, CO 80235, <http://www.awwa.org>.

¹ This practice is under the jurisdiction of ASTM Committee **F17** on Plastic Piping Systems and is the direct responsibility of Subcommittee **F17.20** on Joining.

Current edition approved Nov. 1, 2013. Published January 2014. Originally approved in 2006. Last previous edition approved in 2012 as F2620 – 12. DOI: 10.1520/F2620-13.

*A Summary of Changes section appears at the end of this standard

3.2.1 *Procedure 1, Socket Fusion*—The socket-fusion procedure involves simultaneously heating the outside surface of a pipe end and the inside of a fitting socket, which is sized to be smaller than the smallest outside diameter of the pipe. After the proper melt has been generated at each face to be mated, the two components are joined by inserting one component into the other. See Fig. 1. The fusion bond is formed at the interface resulting from the interference fit. The melts from the two components flow together and fuse as the joint cools. Optional alignment devices are used to hold the pipe and socket fitting in longitudinal alignment during the joining process; especially with pipe sizes IPS 3 in. (89 mm) and larger. Automated socket fusion is not addressed in this procedure.

3.2.2 *Procedure 2, Butt Fusion*—The butt-fusion procedure in its simplest form consists of heating the squared ends of two pipes, a pipe and a fitting, or two fittings, by holding them against a heated plate, removing the heater plate when the proper melt is obtained, promptly bringing the ends together, and allowing the joint to cool while maintaining the appropriate applied force.

3.2.2.1 An appropriately sized butt fusion machine is used to clamp, align and face the pipe or fitting ends and to apply the specified fusion force. See Fig. 2.

3.2.3 *Procedure 3, Saddle Fusion*—The saddle-fusion procedure involves melting the concave surface of the base of a saddle fitting, while simultaneously melting a matching pattern on the surface of the pipe, bringing the two melted surfaces together and allowing the joint to cool while maintaining the appropriate applied force. See Fig. 3.

3.2.3.1 An appropriately sized saddle fusion machine is used to clamp the pipe main and the fitting, align the parts and apply the specified fusion force.

4. Significance and Use

4.1 The procedures described in Sections 7–9 are primarily intended for (but not limited to) field joining of polyethylene (PE) pipe and fittings, using suitable equipment and appropriate environmental control procedures. When properly implemented, strong pressure/leak-tight joints are produced. When these joints are destructively tested, the failure occurs outside the fusion joined area.

4.2 Melt characteristics, average molecular weight and molecular weight distribution are influential factors in establishing suitable fusion parameters; therefore, consider the manufacturer’s instructions in the use or development of a specific fusion procedure. See Annex A1.

4.3 The socket fusion, butt fusion, and saddle fusion procedures in this practice are suitable for joining PE gas pipe and fittings, PE water pipe and fittings, and PE general purpose pipes and fittings made to PE product specifications from organizations such as ASTM, AWWA, API, and ISO that are used in pressure, low pressure and non-pressure applications. For gas applications, qualification of the procedure by testing joints made using the procedure in accordance with regulations from the authority having jurisdiction are required.

5. Operator Experience

5.1 Skill and knowledge on the part of the operator are required to obtain a good quality joint. This skill and knowledge is obtained by making joints in accordance with proven procedures under the guidance of skilled operators. Evaluate operator proficiency by testing sample joints.

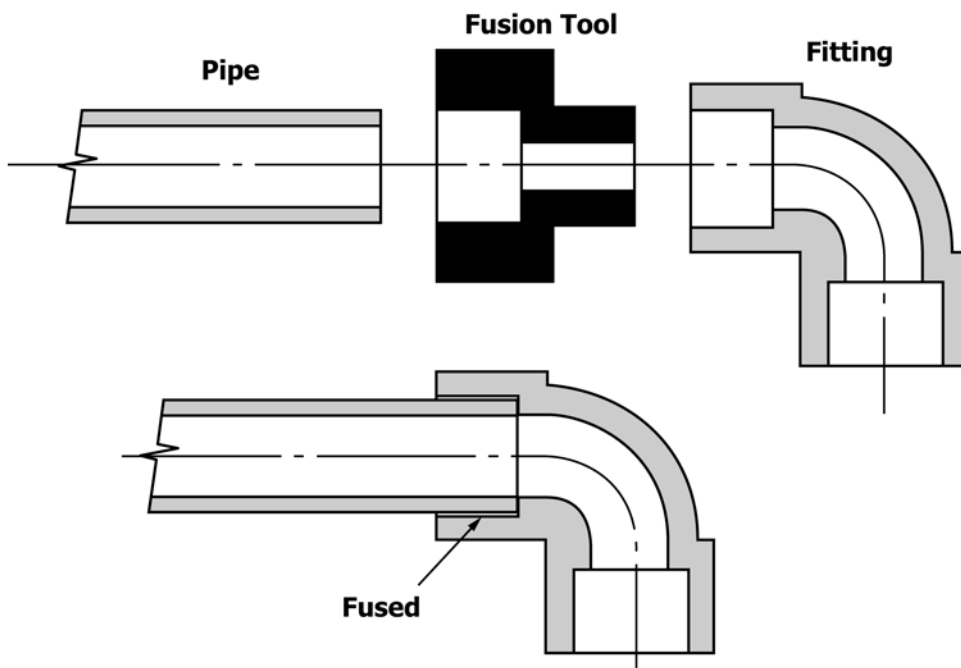

FIG. 1 Socket Fusion

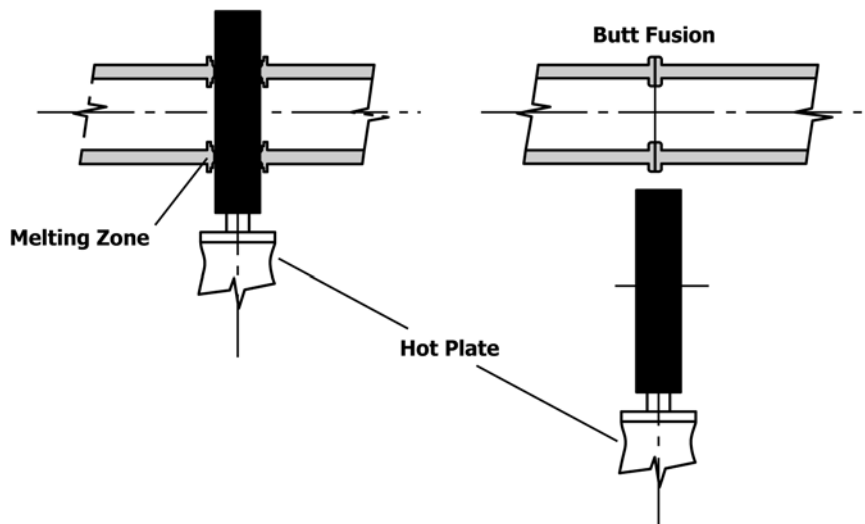

FIG. 2 Butt Fusion

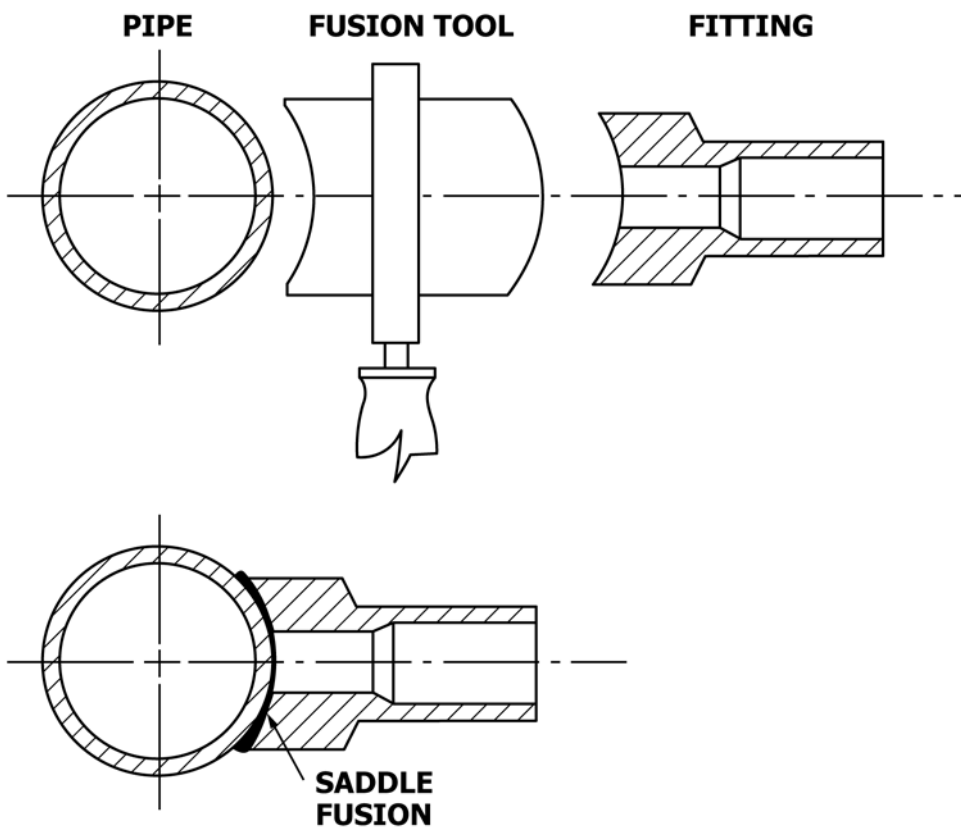

FIG. 3 Saddle Fusion

5.2 The party responsible for the joining of polyethylene pipe and fittings shall ensure that detailed procedures developed in conjunction with applicable codes and regulations and the manufacturers of the pipe, fittings, and joining equipment involved, including the safety precautions to be followed, are issued before actual joining operations begin.

6. Apparatus—General Recommendations

6.1 *Heating Tool*—Electric heating tools come in a variety of sizes that match the fusion machines capabilities. They are

designed with enough wattage and electronic control to maintain the specified heater face temperature required in this procedure. The range of the heater control shall be larger than the heating temperature specification (the typical control range is 50°F (30°C) above and below the maximum and minimum required heating tool surface temperatures. Electric heating plates maintain consistent fusion temperatures when provided with an adequate power source.

6.2 *Heating Tool Faces*—Heating tools may be made from materials such as aluminum, stainless steel, copper, or copper alloys. Polyethylene material may stick to hot metal heating surfaces. This sticking may be minimized by applying a non-stick coating to the heating surfaces or by fitting a high-temperature, non-stick fabric over the heating surfaces. The heating plate surfaces, coated or uncoated, shall be kept clean and free of contaminants such as dirt, grease and plastic build-up, which may cause excessive sticking and create unsatisfactory joints. Most of these contaminants are removed from the hot tool surfaces using a clean, dry, lint-free, non-synthetic cloth such as cotton. Do not use synthetic fabrics which may char and stick to the fusion surface. Some pigments, such as carbon black, may stain a heating surface and probably cannot be removed; such stains will not contaminate the joint interface.

6.2.1 After a period of time in service, non-stick coatings or fabrics will deteriorate and become less effective. Deteriorated fabrics shall be replaced, and worn, scratched, or gouged non-stick coatings shall be re-coated when they lose effectiveness. Heat fusion quality may be adversely affected by deteriorated non-stick surfaces. Spray-on chemicals, such as non-stick lubricants or oils shall not be applied to heating iron surfaces as they will contaminate the joint.

6.3 *Temperature Indicator*—Heating tools shall be equipped with a thermometer or other built-in temperature indicating device. This device indicates the internal temperature of the heating iron, which is usually higher than temperature of the heating tool surfaces. Use a pyrometer, or other temperature measuring device, on the first joint of the day and periodically during the day to verify the temperature of the tool face surfaces within the pipe or fitting contact area. Select multiple checkpoints to ensure uniform surface temperature. An infrared pyrometer is calibrated by comparison to a calibrated surface pyrometer and adjusted to agree on each heating tool.

NOTE 2—A significant temperature variation, that is, cold spots, on the heating tool surfaces may indicate a faulty heating iron which may need to be serviced before it can be used.

7. Procedure 1—Socket Fusion

7.1 Apparatus:

7.1.1 *Socket Fusion Tools*—Socket fusion tools consist of a heating tool, heating tool faces, rounding clamps (cold rings), depth gage/chamfer tools, and pipe/fittings made to ASTM specifications.

7.1.2 *Heating Tool*—In order to obtain a proper melt, it is necessary for a uniform temperature to be maintained across the heating tool faces. An electrical tool shall have sufficient wattage and control to maintain the specified surface temperature of the tool faces.

7.1.3 *Heating Tool Faces*—Consisting of two parts, a male end for the interior socket surface and a female end for the exterior pipe surface. Both parts shall be made to such tolerances as to cause an interference fit. Heating tool faces are produced to Specification **F1056** dimensions, and are coated with a non-stick material to keep melted pipe and fitting material from sticking to the face.

7.1.4 *Alignment Jig*—The alignment jig is an optional tool which consists of two sets of devices holding the components

in alignment to each other. One set of holding devices is fixed, and the other allows longitudinal movement for making the joint.

7.1.5 *Rounding Clamps*, (cold ring) to maintain roundness of the pipe and control the depth of pipe insertion into the socket during the joining operation.

7.1.6 *Depth Gage*, for proper positioning of the rounding clamp on the pipe.

7.1.7 *Chamfering Tool*, to bevel the end of the pipe.

NOTE 3—The depth gage and chamfering tool may be combined into a single tool.

7.1.8 *Tubing Cutter*, to obtain a square end cut on the pipe.

7.1.9 *Fitting Puller*, an optional tool to assist in the removal of the fitting from the heating tool and to hold the fitting during assembly.

7.2 Procedure:

7.2.1 Attach the proper size heater faces to the heating tool, and bring the surface temperature of the tool faces to 490 to 510°F (254 to 266°C). Use a pyrometer, or other temperature measuring device, on the first joint of the day and periodically during the day to verify the temperature of the tool face surfaces within the pipe or fitting contact area. Select multiple checkpoints to ensure uniform surface temperature. Heating tool thermometers measure the internal temperature of the heating tool, which is typically higher than the surface temperature of the heating tool faces.

7.2.2 Cut the pipe end squarely, and clean the pipe end and fitting, both inside and outside, by wiping with a clean, dry, lint-free, non-synthetic cloth such as cotton. If this does not remove the contamination, refer to **X1.7.1**.

7.2.3 Chamfer the outside edge of the pipe end slightly and fix the rounding clamp about the pipe as determined from the depth gage. (See **Note 4**.)

7.2.4 Clean the heater adapters by wiping them with a clean, dry, lint-free, non-synthetic cloth such as cotton to remove any contamination from the surfaces. Push the socket fitting onto the preheated fitting tool face first, and then push the pipe into the pipe-side tool face until the rounding clamps make contact with the heating faces.

7.2.5 Heat the pipe end and the fitting socket for the time required in **Table 1**.

7.2.6 At the end of the heating time, simultaneously remove the pipe and fitting straight out from the tool, using a snap action. Immediately insert the pipe straight into the socket of the fitting so the rounding clamp is flush against the end of the fitting socket. Hold or block the joint in place to cool for the time specified in **Table 1**. (For ambient temperatures 100°F and higher, additional cooling time may be needed.)

7.2.7 Remove the rounding clamp, and inspect the melt pattern at the end of the socket for a complete impression of the rounding clamp in the melt surface. There shall be no gaps, voids, or un-bonded areas. Visually inspect and compare the joint against recommended appearance guidelines (see **Appendix X2**). Allow the joint to cool an additional five (5) minutes before exposing the joint to any type of stresses (that is, burial, testing or fusing the other end of the fitting.)

TABLE 1 Socket Fusion Time Cycles

Pipe Size	PE 2406/ PE 2708		PE 3408/ PE 3608/ PE 4710	
	Heating Time Seconds	Cooling Time Seconds	Heating Time Seconds	Cooling Time Seconds
½ in CTS	6-7	30	6-10	30
¾ in CTS	6-7	30	6-10	30
1 in. CTS	9-10	30	9-16	30
1 ¼ in. CTS	10-12	30	10-16	30
½ in. IPS	6-7	30	6-10	30
¾ in. IPS	8-10	30	8-14	30
1 in. IPS	10-12	30	15-17	30
1¼ in. IPS	12-14	45	18-21	60
1½ in. IPS	14-17	45	20-23	60
2 in. IPS	16-19	45	24-28	60
3 in. IPS	20-24	60	28-32	75
4 in. IPS	24-29	60	32-37	75

7.2.8 Allow for extremes in weather when making field joints. Heating times, dimensional changes, etc., are affected by extreme weather conditions.

NOTE 4—Some recommend using a 50-60 grit emery or garnet cloth to roughen the outside of the pipe and inside of the fitting as a means of minimizing any possible skin interface when making the fusion. Sandpaper is not recommended for this purpose, as it might disintegrate and contaminate the joint interface. If roughening is performed, first clean the surfaces before roughening with a clean cloth or water. Once the pipe or fitting surfaces have been roughened and clean material has been exposed, water cannot be used to clean the pipe surfaces. Clean dust and particles from the roughened surfaces afterwards by cleaning the pipe or fitting ends with a clean dry lint-free, non-synthetic cloth such as cotton.

8. Procedure 2—Butt Fusion

8.1 Apparatus:

8.1.1 *Heating Tool*—The heating tool shall have sufficient area to adequately cover the ends of the size of pipe to be joined. This electrical tool shall have sufficient wattage and control to maintain the specified surface temperature of the tool faces. It shall also be equipped with heater faces that are coated with a non-stick material to prevent sticking to the pipe surface.

8.1.2 *Butt Fusion Machine*—A Butt Fusion Machine has three basic parts: (1) a stationary clamping fixture and a movable clamping fixture for aligning and holding each of the two parts to be fused. This may or may not include the power

supply to operate the machine; (2) a facer for simultaneously preparing the ends of the parts to be joined (Note 5); and (3) appropriate inserts for clamping different pipe sizes or fitting shapes. Butt Fusion Machines are operated manually or hydraulically. Some have their own power supply and some require a separate generator. They are available in a variety of sizes to fuse pipe and tubing produced to ASTM and other industry specifications.

NOTE 5—A facer is a rotating cutting device used to square-off the pipe or fitting ends to obtain properly mating fusion surfaces. If so equipped, facing should continue until a positive mechanical stop on the butt fusion machine is reached.

8.1.3 *Pipe Support Stands*—Optional pipe support stands or racks are used to support the pipe at both ends of the butt fusion machine to assist with pipe loading and alignment.

8.2 Setup:

8.2.1 Butt fusion machine setup parameters are prescribed in Table 2.

8.2.2 An interfacial pressure (IFP) of 60 to 90 psi (0.41 to 0.62 MPa) is used to determine the force required to butt fuse the pipe components. For manually operated fusion machines, enough force should be applied to roll the bead back to the pipe surface. A torque wrench may be used to apply the proper force. Manual fusion without a torque wrench has been used successfully by many gas utilities. For hydraulically operated

TABLE 2 Butt Fusion Machine Setup Parameters

Setup Parameter		Required Condition
Manual Butt Fusion Machine	Hydraulic Butt Fusion Machine	
Set heating tool temperature and heat to specified temperature		The surface temperature of heating tool faces must be 400 to 450°F (204 to 232°C). (See X1.1.) A pyrometer or other surface temperature measuring device should be used periodically to insure proper surface temperature of the heating tool faces.
Install inserts	Install inserts	Install inserts for the pipe OD or the fitting being fused.
Electric power supply	Electric power supply	Check field generator for adequate power supply and fuel sufficient to complete the fusion joint.
Manual pressure	Set facing pressure	As required. Observe butt fusion machine manufacturer's instructions for setting facing pressure.
Manual pressure	Set heating pressure	Observe the pipe and butt fusion machine manufacturer's instructions for setting heating pressures.
Manual pressure	Set fusion joining pressure	Determine fusion joining pressure for the pipe OD and dimension ratio (DR) using 60 to 90 psi (414 to 621 kPa) interface pressure. Observe pipe and butt fusion machine manufacturer's instructions to determine the theoretical fusion joining pressure.
	Determine drag pressure	Drag pressure is the amount of pressure required to get the carriage to move. Add this pressure to the theoretical fusion joining pressure to get the actual machine gage pressure to set.

fusion machines, the IFP is multiplied by the pipe area (A_p) to obtain the fusion force required in pounds. The fusion force required is then divided by the total effective piston area (TEPA) of the fusion machine carriage to obtain the theoretical fusion pressure (TFP) (See Eq 2). The drag pressure (P_D) is then added to the TFP to obtain the fusion machine gauge pressure (P_G) in psig required by the machine, see (Eq 1). (TFP and IFP are *not* the same value.) P_D is found by bringing the faced pipe ends within 2 in. (50 mm) of each other and increase the pressure on the carriage until it starts moving. Back off the pressure until the carriage is barely moving and record the drag pressure in psig. The equations used to calculate for the fusion machine gage pressure is shown below. These equations only apply when using a hydraulic fusion machine.

$$P_G = \text{TFP} + P_D \quad (1)$$

$$\text{TFP} = (A_p \times \text{IFP}) / \text{TEPA} \quad (2)$$

$$A_p = (\text{OD} - t) \times t \times 3.1416 \quad (3)$$

where:

- P_G = Fusion Machine Gauge Pressure, psig
- TFP = Theoretical Fusion Pressure, psig
- IFP = Interfacial Pressure, 60 – 90 psig
- TEPA = Total Effective Piston Area, in² – Supplied by fusion machine manufacturer
- P_D = Fusion Machine Drag Pressure, psig
- A_p = Pipe Area, in²
- OD = Pipe Outside Diameter, in
- t = Pipe Wall Thickness, in

NOTE 6—Interfacial pressure is used to determine butt fusion joining pressure settings for hydraulic butt fusion machines when joining specific pipe diameters and DR's. Interfacial pressure is *not* the gauge pressure. A slide rule or a gauge pressure calculator obtained from the machine's manufacturer can be used as a tool for the calculation.

8.3 Procedure:

8.3.1 Clean the inside and outside of the components (pipe or pipe and fitting) to be joined with a clean, dry, lint-free, non-synthetic cloth such as cotton. Remove all foreign matter from the piping component surfaces where they will be clamped in the butt fusion machine. If this does not remove the contamination, refer to X1.7.1.

8.3.2 If applicable, place pipe support stands at both ends of the butt fusion machine and adjust the support stands to align the pipe with the fusion machine centerline. Install the pipes or fittings being joined in the stationary and movable clamps of the butt fusion machine. Leave enough pipe protruding through the clamps to allow for facing and clamp the pipe or fitting in the machine.

8.3.2.1 Take care when placing pipe or fittings in the butt fusion machine. Pipes shall be aligned before the alignment clamp is closed. Do not force the pipe into alignment by pushing it against the side of an open butt fusion machine clamp. Pipes that are freshly cut and molded fittings generally do not have toe-in, and when mated to old-cut pipe or fabricated fittings, removing toe-in can ease adjustment for high-low alignment.

8.3.3 Face the piping component ends until the facer bottoms out on the stops and is locked between the jaws to establish clean, parallel mating surfaces between the pipe/fitting ends (see Note 5). Move the carriage to separate the pipe

ends from the facer, remove the facer and all shavings and debris from the facing operation by brushing away with a clean, dry, lint-free, non-synthetic cloth such as cotton. Bring the pipe/fitting ends together at facing pressure. A visual inspection of this operation should verify a square face, perpendicular to the pipe centerline on each pipe end and with no detectable gap.

8.3.4 Check the pipe ends for high-low alignment and out-of-roundness. If adjustment is needed, adjust the high side down by tightening the high side clamp. Do not loosen the low side clamp or slippage may occur during fusion. Re-face the pipe or fitting ends if excessive adjustment is required (more than 180° rotation of the clamp knob) and remove any shavings from the re-facing operation with a clean, dry, lint-free, non-synthetic cloth such as cotton. The maximum OD high-low misalignment allowed in the butt fusion procedure is to be less than 10 % of the pipe minimum wall thickness.

8.3.5 Verify that the heater surface temperatures are in the specified temperature range 400 to 450°F (204 to 232°C). (See Appendix X1.) A pyrometer or other surface temperature measuring device should be used before the first joint of the day and periodically throughout the day to insure proper temperature of the heating tool face. All pyrometers are sensitive to usage techniques. Carefully follow the manufacturer's instructions for best results.

8.3.5.1 Clean the contact surfaces of the heating tool with a clean, dry, lint-free, non-synthetic cloth such as cotton. Place the heating tool in the butt fusion machine between the piping component ends and bring the pipe or fitting ends into full contact with the heating tool at fusion pressure. Briefly ensure full contact between piping component ends and the heating tool and then reduce the pressure to drag pressure but without breaking contact between the piping component ends and the heating tool. (On larger pipe sizes, (14 in. and larger) hold fusion pressure until a slight melt is observed around the circumference of the pipe or fitting before reducing pressure. This normally varies from about 10 s on 14 in. pipe to greater than 2 min on 36 and larger pipe sizes.)

8.3.5.2 Once the indication of melt is observed around the circumference of the pipe, begin the heat soak by reducing the pressure to maintain contact, without force, while a bead of molten polyethylene develops between the heater and the pipe or fitting ends. For 14 in. IPS pipe sizes and larger, maintain the heat soak for a minimum of 4.5 minutes for every inch (25.4 mm) of pipe wall thickness. (example: minimum heat soak time for a pipe with .50 in. (12.7mm) wall would be 2 min 15 s). Continue heating the pipe ends until the melt bead size has developed against the heater face per Table 3.

8.3.6 When the proper bead size is observed, quickly move the piping component ends away from the heating tool, remove the heating tool and quickly inspect the pipe ends.

8.3.6.1 Acceptable melt appears flat and smooth with no unmelted areas. Unacceptable melt appearance is any combination of a concave surface, unmelted areas, a bubbly pock-marked sandpaper-like surface or melted material sticking to heating tool surfaces (see Fig. X2.7). Low strength joints result from unacceptable melt appearance. Discontinue the joining

TABLE 3 Minimum Melt Bead Size

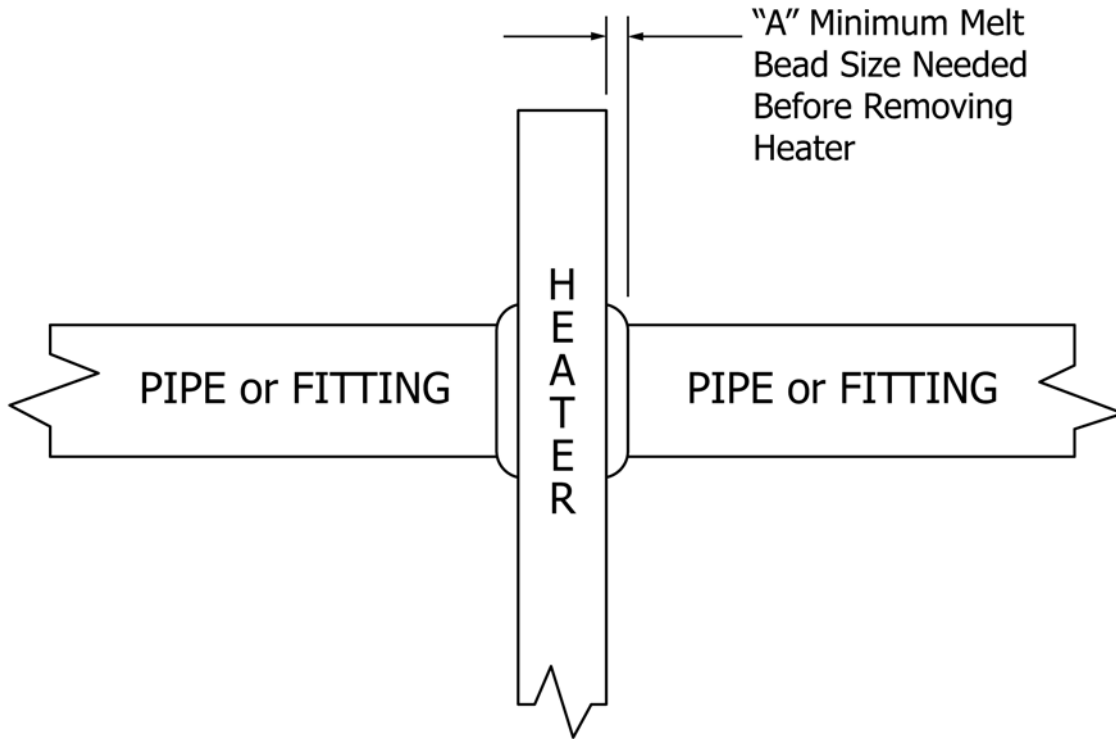

Pipe (OD) [Outside Diameter, in. (mm)]	"A" Minimum Bead Size, in. (mm)
< 2.37 (60)	1/32 (1)
≥ 2.37 (60) ≤ 3.5 (89)	1/16 (1.5)
> 3.5 (89) ≤ 8.62 (219)	3/16 (5)
> 8.62 (219) ≤ 12.75 (324)	1/4 (6)
> 12.75 (324) ≤ 24 (610)	5/8 (10)
> 24 (610) ≤ 36 (900)	7/16 (11)
> 36 (900) ≤ 65 (1625)	9/16 (14)

procedure, allow the component ends to cool completely and restart from 8.3.1. (See Appendix X2.)

8.3.6.2 The maximum time allowed for opening the machine, removing the heater and bringing the pipe ends together is shown in Table 4. For tubing sizes that are generally butt fused with mechanical fusion machines (not hydraulically controlled) (1/2 CTS to 1 1/2 in. IPS), the maximum open/close time is 4 s. The quicker you can safely do this process, the better. See A1.4.3.1 for guidance on butt fusion in cold temperatures. Do not slam the pipe ends together.

NOTE 7—A concave melt surface is caused by unacceptable pressure during heating.

8.3.6.3 The correct fusion pressure rolls both melt beads over so that they touch the piping component OD surfaces. Do not use excessive or insufficient force (more than or less than the fusion interfacial pressure range). If the components are brought together with excessive force, molten material may be pushed out of the joint and cold material brought into contact forming a “cold” joint. If too little force is used, voids and weak bonded areas can develop in the joint as molten material cools and contracts.

8.3.7 Hold the molten joint immobile under fusion pressure until sufficiently cooled. Cooling under pressure before removal from the butt fusion machine is important in achieving

TABLE 4 Maximum Heater Plate Removal Times

NOTE 1—Fusion joints made in an enclosed and controlled factory fabrication environment will tolerate and may use longer maximum heater removal times.

Field Applications Pipe Wall Thickness, in. (mm)	Max. Heater Plate Removal Time Seconds
0.17 to 0.36 (5 to 9)	8
>0.36 to 0.55 (9 to 14)	10
>0.55 to 1.18 (14 to 30)	15
>1.18 to 2.5 (30 to 64)	20
>2.5 to 4.5 (64 to 114)	25

joint integrity. Maintain fusion pressure against the piping component ends for a minimum of 11 minutes per inch (25.4 mm) of pipe wall. For ambient temperatures 100°F and higher, additional cooling time may be needed. Avoid high stress such as pulling, installation or rough handling for an additional 30 min or more after removal from the fusion machine (only 10 minutes additional cooling time is required for IPS 1 in. and smaller pipe sizes). Do not apply internal pressure until the joint and surrounding material have reached ambient air temperature. (See Appendix X1.)

NOTE 8—Pouring water or applying wet cloths to the joint to reduce cooling time is not acceptable. Applying conditioned air is acceptable only as part of a controlled cooling cycle procedure where testing demonstrates that acceptable joints are produced using the controlled cooling cycle procedure.

8.3.7.1 Visually inspect and compare the joint against the butt fusion bead visual inspection acceptance guideline in Fig. 4. The v-groove between the beads should not be deeper than half the bead height above the pipe surface. When butt fusing to molded fittings, the fitting-side bead may display shape

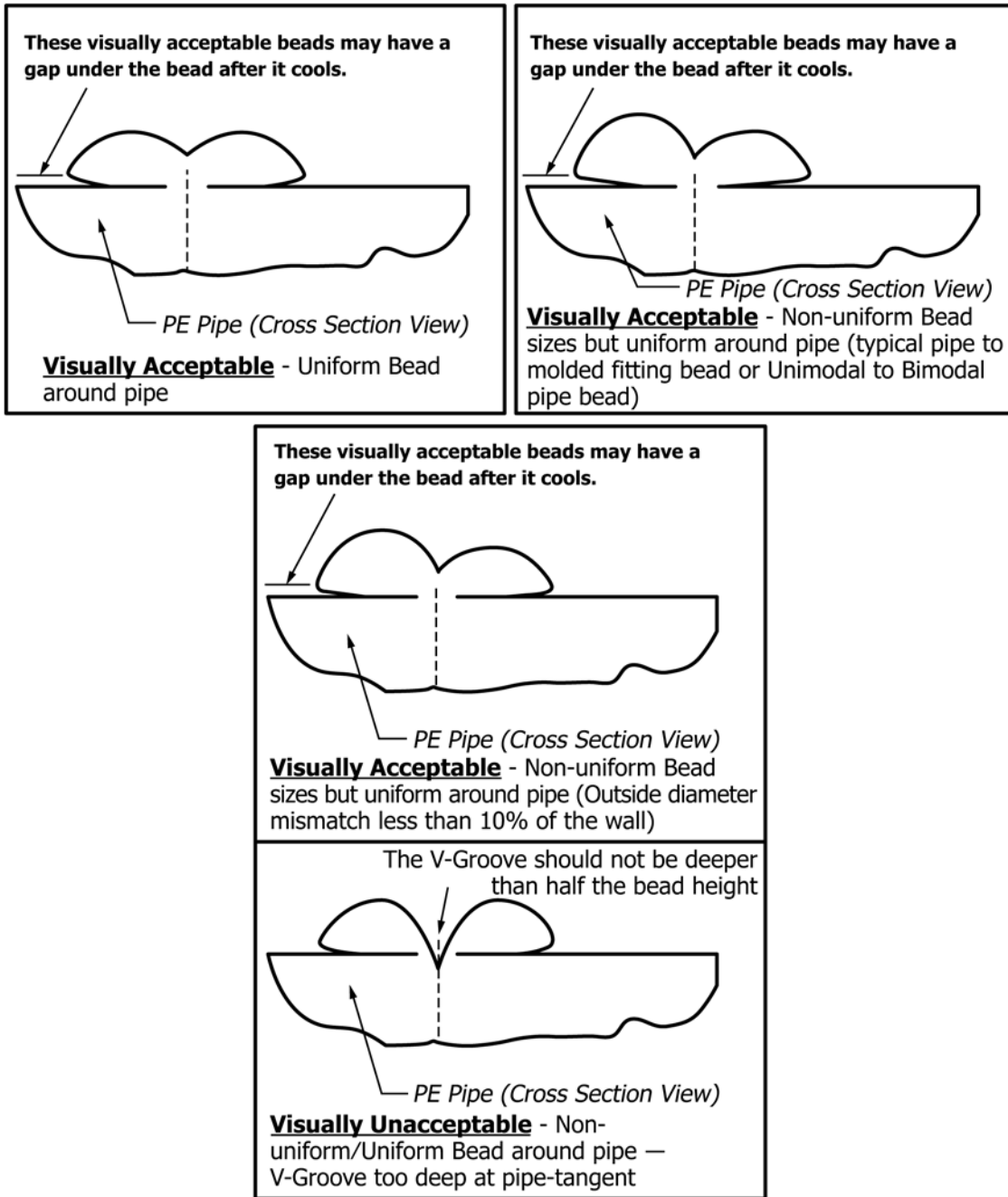

FIG. 4 Outside Diameter Butt Fusion Bead Guideline

irregularities such as minor indentations, deflections and non-uniform bead rollover from molded part cooling and knit lines. In such cases, visual evaluation is based mainly on the size and shape of the pipe-side bead. (See [Appendix X2](#) for additional guidance.)

9. Procedure 3—Saddle Fusion

9.1 Apparatus:

9.1.1 *Heating Tool and Faces*—This electrical tool shall have sufficient wattage and control to maintain the specified surface temperature of the tool faces. The serrated or smooth faces are matched sets, by pipe size, of concave and convex blocks, which bolt or clamp onto a flat heating tool. The heating faces are coated with a non-stick material to prevent sticking to the pipe or fitting surfaces.

9.1.2 *Saddle Fusion Tool*—This tool clamps to the main, rounding and supporting the main for good alignment between the pipe and fitting. It holds the fitting, in correct alignment to the main. It also applies and indicates the proper force during the fusion process. A support or bolster is clamped to IPS 6 in. (168 mm) and smaller main pipe opposite the fitting installation area to support the main and assist in rounding the pipe.

9.1.3 *Optional Flexible Heat Shield*—A flexible heat resistant metal or insulated fabric pad used to help establish a melt pattern on larger mains before applying heat to the fitting.

9.2 Saddle Fusion Terminology:

9.2.1 *Initial Heat (Bead-up)*—The heating step used to develop an initial melt bead on the main pipe.

9.2.2 *Initial Heat Force (Bead-up Force)*—The force (lb) applied to establish an initial melt pattern on the main pipe. The Initial Heat Force is determined by multiplying the fitting base area (in.²) by the initial interfacial pressure 60 (lb/in.²).

9.2.3 *Heat Soak Force*—The force (lb) applied after an initial melt pattern is established on the main pipe. The Heat Soak Force is the minimum force (essentially zero pounds) that ensures that the fitting, heater and main stay in contact with each other.

9.2.4 *Fusion Force*—The force (lb) applied to establish the fusion bond between the fitting and the pipe. The fusion Force is determined by multiplying the fitting projected base area (in.²) by the fusion interfacial pressure 30 (lb/in.²).

9.2.5 *Total Heat Time*—A time that starts when the heater is placed on the main pipe and initial heat force is applied and ends when the heater is removed.

9.2.6 *Cool Time*—The time required to cool the joint to approximately 120°F (49°C). The fusion force must be maintained for 5 min on IPS 1¼ in. (42 mm) or 10 min for all other main sizes, after which the saddle fusion equipment can be removed. The joint must be allowed to cool undisturbed for an additional 30 min before tapping the main or joining to the branch saddle.

9.2.7 *Interfacial Area for Rectangular Base Fittings*—The major width times the major length of the saddle base, without taking into account the curvature of the base or sides, minus the area of the hole in the center of the base.

9.2.8 *Interfacial Area for Round Base Fittings*—The radius of the saddle base squared times π (3.1416) without taking into account the curvature of the base or sides, minus the area of the hole in the center of the base.

9.2.9 *Fitting Label*—The initial heat force, heat soak force and the fusion force will be listed on a fitting label in the lower right hand corner of the fitting for some manufacturer's saddle fusion fittings. This will eliminate the need to calculate the fusion forces in the field (for example, 180/0/90). If the label is not present, the heat and fusion forces need to be calculated.

9.3 Setup:

9.3.1 Select and install the proper heating tool faces to the heating tool based on the main size and fitting base size. Consult the pipe, fitting or equipment manufacturer's recommendations.

9.3.2 Plug in the heating tool and bring the heating tool face surfaces to 490 to 510°F (254 to 266°C) (see [Table 5](#)). A pyrometer or other surface temperature measuring device is used to determine and periodically check the heating tool surface temperature. Heating tool thermometers measure the internal temperature of the heating tool which is typically higher than the surface temperature of the heating tool faces.

9.3.3 Install the proper clamps in the Saddle Fusion Tool for the main size to be fused. Install the proper fitting clamp for the fitting to be joined. Consult the pipe, fitting or equipment manufacturer's recommendations.

9.4 Procedure:

9.4.1 Preparation:

9.4.1.1 Clean the inside and outside of the components (pipe or pipe and fitting) to be joined with a clean, dry, lint-free, non-synthetic cloth such as cotton. Remove all foreign matter from the piping component surfaces where they will be

TABLE 5 Generic Saddle Fusion Parameters

Heater Adapter Surface Temperature	500 ± 10°F (260 ± 6°C)
Initial Interfacial Pressure	60 ± 6 psi (4.14 ± 0.41 bar)
Heat Soak Interfacial Pressure	0 psi
Fusion Interfacial Pressure	30 ± 3 psi (2.07 ± 0.20 bar)
Total Heating Time on Main—1¼ in. IPS Pressure Main	15 s max
Total Heating Time on Main—2 in. IPS Pressure Main	25 to 35 s max
Total Heating Time on non-pressure 1¼ in. IPS, 2 in. IPS mains, and on pressure or non-pressure 3 in. IPS and larger mains.	Look for a ¼ in. (1.6 mm) bead around the fitting base

clamped in the butt fusion machine. If this does not remove the contamination, refer to **X1.7.1**. Install the Saddle Fusion Tool on the main according to the manufacturer's instructions. The tool should be centered over a clean, dry location where the fitting will be fused. Secure the tool to the main. A main bolster or support is recommended under the pipe on IPS 6 in. (168 mm) and smaller main pipe sizes.

9.4.1.2 Abrade or scrape the surface of the main, where the fitting will be joined, approximately 0.007 in. (.178mm) deep to remove any oxidation or contamination. This can be done before or after the Tool is attached to the main. The abraded/scraped area must be larger than the area covered by the fitting base. It is important that the pipe surface be free from any type of contaminates that may be spread before the scraping or abrading process begins. Marks can be made on the outer surface of the pipe to aid in visual indication of abrading/scraping coverage, however the marks should be made with a non-petroleum based fast drying marker. After abrading/scraping, clean the pipe or fitting ends with a clean, dry, lint-free, non-synthetic cloth such as cotton. All markings on the pipe surface should be removed before beginning the heat cycle.

9.4.1.3 Abrade the fusion surface of the fitting with 50 to 60 grit utility cloth; remove all dust and residue with a clean, dry, lint-free, non-synthetic cloth such as cotton. Insert the fitting in the Saddle Fusion Tool loosely. Using the Saddle Fusion Tool, move the fitting base against the main pipe and apply about 100 lbf to seat the fitting. Secure the fitting in the Saddle Fusion Tool.

9.4.2 *Heating Procedure for Small Fittings (<2 in. IPS)* (see **Table 5**):

9.4.2.1 Clean the heating tool faces with a clean, dry, lint-free, non-synthetic cloth such as cotton. Place the heating tool on the main centered beneath the fitting base. Immediately move the fitting against the heater faces, apply the Initial Heat Force (see fitting label), and start the heat time. Apply the Initial Heat Force until melt is first observed on the crown of the pipe main (Initial Heat is the term used to describe the initial heating (bead-up) step to develop a melt bead on the main pipe and usually is 3 to 5 s) and then reduce the force to the Heat Soak Force (Bead-up force) (see fitting label). Maintain the Heat Soak Force until the Total Heat Time is complete. Total Heat Time ends:

(1) When the Total Heating Time expires for a pressurized IPS 1¼ in. (42 mm) or IPS 2 in. (63 mm) main, or

(2) When a melt bead of about 1/16 in. (2 mm) is visible all around the fitting base for a IPS 1¼ in. (42 mm) or IPS 2 in. (63 mm) non-pressurized main, or a larger pressurized or non-pressurized main, (see **Table 5**).

9.4.2.2 At the end of the Total Heat Time, remove the fitting from the heater and the heater from the main with a quick snapping action. Quickly check for a complete and even melt pattern on the pipe main and fitting heated surfaces (no unheated areas).

9.4.3 *Heating Procedure for Large Fittings (>IPS 3 in.) and Large Mains (>IPS 6 in.)* (see **Table 5**):

9.4.3.1 Place the heating tool on the main centered beneath the fitting base, and then place the Flexible Heat Shield

between the heating tool and the fitting base. (This step usually requires an assistant to handle the Flexible Heat Shield).

9.4.3.2 Move the fitting against the Flexible Heat Shield, apply Initial Heat Force, and observe melt bead formation on the main all around the heating tool faces. When a melt bead is first visible on the main all around the heating tool faces, in a quick continuous motion, release the Initial Heat Force, raise the fitting slightly, remove the Flexible Heat Shield, move the fitting against the heating tool face, apply Initial Heat Force and start the heat time. When a melt bead is first visible all around the fitting base (usually about 3 to 5 s) immediately reduce applied force to the Heat Soak Force (usually zero). Maintain the Heat Soak Force until the **Table 5** Total Heat Time ends.

NOTE 9—During heating, hold the heating tool in position by lightly supporting the heating tool handle. If not supported, the heating tool can slip out of position or displace the main or fitting melt and result in a poor joint.

9.4.3.3 At the end of the Total Heat Time, remove the fitting from the heater and the heater from the main with a quick snapping action. Quickly check for a complete and even melt pattern on the pipe main and fitting heated surfaces (no unheated areas). A mirror may be needed to check the bottom of the fitting.

9.4.4 *Fusion and Cooling* (see **Table 5**):

9.4.4.1 Whether or not the melt patterns are satisfactory, press the fitting onto the main pipe very quickly (within 3 s) after removing the heater and apply the Fusion Force (see the fitting label). Maintain the Fusion Force on the assembly for 5 min on IPS 1¼ in. (42 mm) and for 10 min on all larger sizes, after which the saddle fusion equipment may be removed. (Fusion Force adjustment may be required during Cool Time, but never reduce the Fusion Force during cooling.)

9.4.4.2 Cool the assembly for an additional 30 min before rough handling, branch joining or tapping the main. (If the melt patterns were not satisfactory or if the fusion bead is unacceptable, cut off the saddle fitting above the base to prevent use, relocate to a new section of main, and make a new saddle fusion using a new fitting.)

NOTE 10—These procedures are based on tests conducted under controlled ambient temperature conditions. Environmental conditions on a job site could affect heating and cooling times. Regardless of job site conditions or ambient temperature, the prescribed heating tool temperature is required. Do not increase or decrease the heating tool temperature. When saddle fittings are fused to pipes that are under pressure, it is important that the surface melt be obtained quickly without too much heat penetration with out exceeding the time guidelines in **Table 5**. Otherwise, too much heat penetration could result in pipe rupture from internal pressure.

9.5 *Visual Inspection*:

9.5.1 Visually inspect and compare the joint against visual inspection guidelines. There shall be three beads, a melt bead around the fitting base, a bead on the main from the edge of the heating tool, and a main pipe melt bead. The fitting and pipe melt beads should be rounded and about 1/8 in. (3 mm) wide all around the fitting base. The heating tool edge bead should be visible all around the fitting base, but may be separate from the main pipe melt bead.

9.5.2 The saddle fusion joint is unacceptable for use if visual bead appearance is unacceptable or if the melted surfaces were unacceptable. To prevent use, cut the fitting off at or just above the base. (See [Appendix X2](#).)

NOTE 11—Look in the lower right hand corner of the fitting label for the forces required for that fitting in pounds force (Initial Heat Force/Heat

Soak Force/Fusion Force) (for example, 180/0/90).

10. Keywords

10.1 butt fusion; fitting; heat fusion; joining; pipe; polyethylene; polyolefin; saddle fusion; socket fusion

ANNEX

(Mandatory Information)

A1. COLD WEATHER PROCEDURES

A1.1 Cold Weather Handling:

A1.1.1 Pipe shall be inspected for damage. Polyolefin Polyethylene pipes have reduced impact resistance in sub-freezing conditions. Avoid dropping pipe in sub-freezing conditions. When handling coiled pipe at temperatures below 40°F (4.44°C), it is helpful to uncoil the pipe prior to installation and let it straighten out. Gradually uncoil the pipe and cover it with dirt at intervals to keep it from recoiling. Always use caution when cutting the straps on coils of pipe because the outside end of a coil may spring out when the strapping is removed.

A1.2 Preparation for Socket, Saddle, and Butt Fusion Joining:

A1.2.1 *Wind and Precipitation*—The heating tool shall be shielded in an insulated container to prevent excessive heat loss. Shield the pipe fusion area and fusion tools from wind, snow, blowing dust, and rain by using a canopy or similar device.

A1.2.2 *Pipe and Fitting Surface Preparation*—The pipe and fitting surfaces to be “joined” or held in clamps shall be dry and clean and free of ice, frost, snow, dirt, and other contamination. Regular procedures for preparation of surfaces to be joined, such as facing for butt fusion and roughening for saddle fusion shall be emphasized. After preparation, the surfaces shall be protected from contamination until joined. Contamination of the area to be fused will likely cause incomplete fusion. Frost and ice on the surfaces of the pipe to be clamped in either a cold ring or alignment jigs may cause slippage during fusion. Inspect coiled pipe to see if it has flattened during storage, which could cause incomplete melt pattern or poor fusion. It may be necessary to remove several inches at the pipe ends to eliminate such distortion. Pipe may have a slight toe-in or reduced diameter for several inches at the end of the pipe. The toe-in may need to be removed before butt fusing to a freshly cut pipe end, or to a fitting.

A1.2.3 *Heating*—Work quickly once pipe and fitting have been separated from the heating tool, so that melt heat loss is minimized, but still take time (no more than 3 s) to inspect both melt patterns. Keep the heater dry at all times. Check the temperature of the heating tool regularly with a pyrometer or other surface temperature measuring device. Keep the heating tool in an insulated container between fusions. Do not increase

heating tool temperature above the specified temperature setting. Gas-fired heating tools are used only in above freezing conditions.

A1.3 Socket Fusion:

A1.3.1 *Pipe Outside Diameter*—Pipe outside diameter contracts when cold. This results in loose or slipping cold rings. For best results, clamp one cold ring in its normal position adjacent to the depth gage. Place shim material (that is, piece of paper or rag, etc.) around the inside diameter of a second rounding ring and clamp this cold ring directly behind the first cold ring to prevent slippage. The first cold ring allows the pipe adjacent to the heated pipe to expand to its normal diameter during the heating cycle.

A1.3.2 *Fitting Condition*—If possible, store socket fittings at a warm temperature, such as in a truck cab, prior to use. This will make it easier to place the fitting on the heating tool because fittings contract when cold.

A1.3.3 *Heating*—At colder temperatures the pipe and fitting contract, thus the pipe slips more easily into the heating tool. At very cold outdoor temperatures (particularly with IPS 2, 3, and 4-in. pipe), the pipe may barely contact the heating surface. Longer heating times are used so that the pipe first expands (from tool heat) to properly contact the heating tool, then develops complete melt. The length of time necessary to obtain a complete melt pattern will depend not only on the outdoor (pipe) temperature but wind conditions and operator variation. Avoid cycles in excess of that required to achieve a good melt pattern. To determine the proper time for any particular condition, make a melt pattern on a scrap piece of pipe, using the heating time as instructed by the pipe manufacturer. If the pattern is incomplete (be sure rounding rings are being used), try a 3 s longer cycle on a fresh (cold) end of pipe. If the melt pattern is still not completely around the pipe end, add an additional 3 s and repeat the procedure. Completeness of melt pattern is the key. Keep the heater dry at all times. Check the temperature of the heating tool regularly and keep the heating tool in an insulated container between fusions.

A1.4 Butt Fusion:

A1.4.1 Joining:

A1.4.1.1 The fusion operator shall be aware of ambient weather conditions during the butt fusion of polyethylene pipe

and fittings and be ready and capable to make adjustments to the fusion procedure if ambient weather conditions change significantly.

A1.4.1.2 The qualified fusion procedure shall provide suitable measures for adjustment of fusion parameters, in particular the heating time, when the ambient temperature changes or during windy conditions. When the ambient temperature becomes colder, it will require a longer heating time to develop an indication of melt and the final bead size. The pipe wall thickness and pipe diameter are primary factors to consider when determining the necessary heating cycle time.

A1.4.1.3 The modifications to the fusion procedure require validation through the production of test fusions and their assessment by comparison to visual guidelines and bend testing.

A1.4.1.4 The specified heating plate temperature range shall not be exceeded to accommodate cold weather conditions.

A1.4.1.5 The fusion pressure must be maintained until a slight melt is observed around the circumference of the pipe or fitting before releasing pressure for the heat soak.

NOTE A1.1—Check for pipe slippage in the fusion machine in cold weather applications. The pipe is stiffer in cold temperatures and the OD of the pipe will shrink slightly, increasing the potential for slippage in the jaws.

A1.4.1.6 Do not apply additional pressure during the heat soak to accommodate cold weather conditions.

A1.4.1.7 Follow the minimum heat soak time for the wall thickness of pipe to be fused per 8.3.5.2. The melt beads formed against the heater surface during the heating soak shall be in accordance with Table 3. It is critical that the melt bead sizes specified in Table 3 be achieved.

A1.4.1.8 When the specified heat soak time and melt bead size has been achieved, the pipe and heater shall be separated in a rapid, snap-like motion. The melted surfaces shall then be joined as soon as possible, within the maximum times allowed in Table 4, so as to minimize cooling of the melted pipe ends. Cool the joint per 8.3.7.

A1.4.2 *Assessment*—Inspection assessment guidelines for fusion joints that are made under cold weather conditions are the same as for fusion joints made at warmer ambient temperatures. Key concerns affecting the quality of cold weather fusion joints are incorrect heating time and application of pressure during heating soak and moisture contamination that could generate a weak fusion joint. Therefore strict adherence to the butt fusion guidelines and adequate butt fusion process controls are the primary means to minimize this probability.

A1.4.2.1 Visual assessment of the finished bead is critical, since signs of incorrect heating, facing or joining force may be evident on the fusion bead. Correct shape of the finished bead, degree of bead rollover to the pipe surface and depth of the v-groove are key indicators (see Fig. 4 and Appendix X2.)

A1.4.3 *Joining in Adverse Weather:*

A1.4.3.1 *Cold Ambient Temperatures Below 32°F (0°C)*—Butt, Saddle or Socket, Fusion is generally not recommended below -4°F (-20°C) without special provisions such as a portable shelter or trailer or other suitable protective measures

with auxiliary heating. When making a butt fusion joint with the ambient temperature is below 3°F(-16°C), the pipe ends shall be pre-heated using a heating blanket or warm air device to elevate the pipe temperature to improve the heating starting condition. With pipe mounted in the fusion machine, an alternate method of pre-heating is to stop the pipe ends within .25-.50 inches (6.4-12.7mm) of the heater plate face to allow the pipe ends to warm for 30 seconds to 2 minutes, depending on the pipe size and wall thickness. The use of direct application open flame devices, such as torches, for heating polyethylene pipe is prohibited due to the lack of adequate heating control and possibility of damage to the pipe ends. When fusing pipe under adverse cold weather or in windy field conditions with blowing dust is required, the provision of portable shelters or trailers with heating should be considered and are recommended to provide more consistent and acceptable working conditions. When fusing coiled pipe when the ambient temperature is below 32°F (0°C), it may be required to remove an end section of pipe from the coil and butt fuse on a straight section of pipe to enable correct pipe alignment. Completed joints shall be allowed to cool to ambient temperature before any stress is applied.

A1.4.3.2 *Wind*—Exposure of the fusion heater plate and pipe to wind can result in unacceptable temperature variations during butt fusions and possible joint contamination. When extreme wind conditions exist, the provision of a suitable shelter is required to protect the pipe and fusion heater plate to ensure a more consistent environment is provided. Wind conditions can develop through the pipe bore and cause unacceptable temperature variations during the heating process. Therefore, open pipe ends may require plugs or covers to prevent this condition. Note: Although wind conditions, during cold weather butt fusion, are the primary concern, wind conditions can affect butt fusion quality at all ambient temperatures by chilling the heated pipe surfaces during the heat soak. This increases the heat soak time to obtain the bead size against the heater surface.

A1.5 *Saddle Fusion:*

A1.5.1 *Surface Preparations*—Regular procedures for roughening the surfaces to be fused on the pipe and the fitting shall be emphasized. After the surfaces have been prepared, particular care shall be taken to protect against contamination.

A1.5.2 *Heating Time*—Make a trial melt pattern on a scrap piece of pipe. A clean, dry piece of wood is used to push the heating tool against the pipe. If the melt pattern is incomplete, add 3 s to the cycle time and make another trial melt pattern on another section of cold pipe. If the pattern is still incomplete, continue 3 s additions on a fresh section of cold pipe until a complete melt pattern is attained. Use this heating cycle for fusions during prevailing conditions. Regardless of the weather or the type of tools used, the important point to remember is that complete and even melt must occur on the fitting and the pipe in order to produce a good fusion joint. This requires pipe preparation to make it clean, straight, round, and well supported.

APPENDIXES

(Nonmandatory Information)

X1. JOINING

X1.1 Parameters and Procedures—These parameters and procedures in this practice are approved by the majority of pipe manufacturers for the majority of the solid wall polyethylene pipe materials on the market today. Consult with the pipe manufacturer to make sure they approve this procedure for the pipe to be joined. Other specific parameters and procedures, such as heater temperature variations, have been developed, tested and approved by some municipalities, utilities, and end users. They are not covered in this specification.

X1.2 Quality Assurance Recommendations—It is recommended that the following steps be followed to help insure quality fusion joints.

X1.2.1 Make sure the equipment or tooling used to make the fusion joints is in good working order and conforms to the equipment manufacturer’s quality assurance guidelines.

X1.2.2 Make sure the operator of the equipment or tooling to be used has had the proper training in the operation of that equipment.

X1.2.3 If possible, use a datalogging device with hydraulic joining equipment to record the critical fusion parameters of pressure, temperature and time for each joint.

X1.2.4 Visually inspect each joint and compare the datalogged records to this approved standard before burying the pipe. (See [Appendix X2](#) for visual guidelines.)

X1.3 Heating Polyethylene (PE) in a Hazardous Environment—Electrically powered heat fusion tools and equipment are usually not explosion proof. When performing heat fusion in a potentially combustible atmosphere such as in an excavation where gas is present, all electrically powered tools and equipment that will be used in the combustible atmosphere shall be disconnected from the electrical power source and operated manually to prevent explosion and fire. For the heating tool, this requires bringing the heating tool up approximately 25°F (14°C) above the recommended maximum surface temperature in a safe area, then disconnecting it from electrical power immediately before use.

X1.4 Butt Fusion of Unlike Wall Thicknesses—The butt fusion procedure in this practice is based on joining piping components (pipes and fittings) made from compatible polyethylene compounds having the same outside diameter and wall thickness (PR) per ASTM or other industry product specifications. In some cases, butt fusion joining of pipes and fittings that have the same outside diameter but unlike wall thickness (different by one standard DR or more) is possible. The quality of butt fusion joints made between pipes of unlike wall thickness is highly dependent on the performance properties of the polyethylene compound used for the pipes or fittings being joined. Consult the pipe or fitting manufacturer

for applicable butt fusion procedures for components with dissimilar wall thicknesses.

X1.5 Butt Fusion of Coiled Pipe—Coiled pipe is available in sizes up to 6 in. IPS. Coiling may leave a set in some pipe sizes that must be addressed in the preparation of the butt fusion process. There are several ways to address this situation:

X1.5.1 Straighten and re-round coiled pipe before the butt fusion process. (Specification [D2513](#) requires field re-rounding of coiled pipe before joining pipe sizes larger than 3 in. IPS.)

X1.5.2 If there is still a curvature present, install the pipe ends in the machine in an “S” configuration with the print lines approximately 180° apart in order to help gain proper alignment and help produce a straight joint. See Fig. X2.15.

X1.5.3 If there is still a curvature present, another option would be to install a straight piece of pipe between the two coiled pipes.

X1.6 Butt Fusion of Pipe with “Toe-In” on the End of the Pipe:

X1.6.1 “Toe-In” is a slight reduction in diameter at the end from pipe extrusion. When butt fusing two extruded pipe segments, the toe-in is normally about the same and therefore the alignment is easily attained. When one end of the pipe is field cut, toe-in is temporarily removed which can affect high-low alignment when butt fusing to a pipe that has not been field cut. Trimming up to 2 in. off the end of the pipe that has not been field cut will usually correct difficulties with high-low alignment. This condition may also occur when joining pipe to molded fittings. In this circumstance as well, trimming up to 2 in. from the pipe end will usually correct difficulties with high-low alignment. For pipe that has been trimmed, toe-in will reoccur after several hours.

X1.7 Contamination of Pipe before Fusion—Introduction of contamination to the pipe can happen in a number of ways and should be avoided by following the precautions listed below:

X1.7.1 Before installing the pipe in the fusion machine, clean the OD, ID and ends with a clean, dry, lint-free, non-synthetic cloth such as cotton. If the contamination cannot be removed this way, wash the pipe with water and a clean cloth or paper towel to remove the contamination, rinse the pipe with water and dry thoroughly with a clean, dry, lint-free, non-synthetic cloth such as cotton or paper towel. If contamination, such as bar oil, was transferred to the pipe ends after cutting, use 90 % or greater isopropyl alcohol or acetone on a clean cloth or isopropyl alcohol wipes on the ends of the pipe to clean the contamination, then rinse with water and dry thoroughly on the pipe ends, ID and OD. It is important that

pipe ends be clean before installing in the fusion machine to avoid contaminating fusion machine parts that contact the pipe ends such as the facer and heater. If the facer or heater becomes contaminated, the contamination may be transferred back to the pipe ends, possibly compromising joint quality. Do not use the facer to remove contamination.

X1.7.2 After the pipe ends are faced and aligned, bring the pipe ends together to prevent dirt and other contaminants from

blowing onto the fusion surfaces. Keep the pipe ends together until you are ready to install the heater for the butt fusion process.

NOTE X1.1—Every effort should be made to make the joint perpendicular to the axis of the pipe. Visually mitered (angled, off-set) joints should be cut out and re-fused (see appearance guidelines in [Appendix X2](#)).

X2. HEAT FUSION VISUAL APPEARANCE GUIDELINE



Acceptable Visual Appearance

Melt bead flattened by cold ring.
No gaps or voids.
Good alignment between pipe and fitting.

FIG. X2.1 Socket Fusion

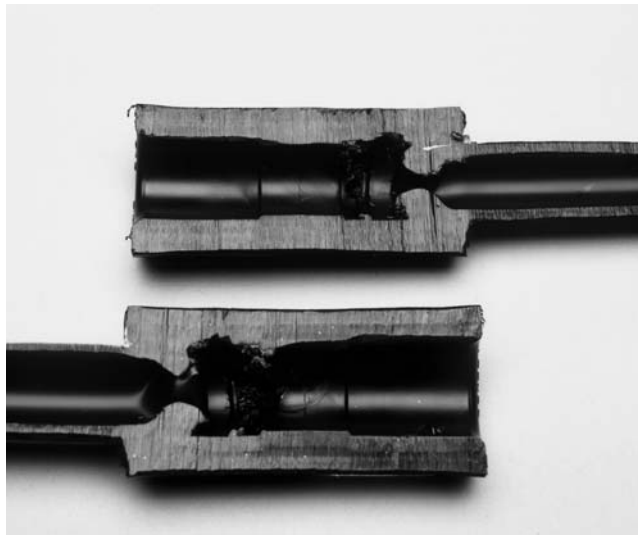

Unacceptable Visual Appearance

Excessive heating.

FIG. X2.2 Socket Fusion



Unacceptable Visual Appearance

Melt bead not flattened against the fitting/cold ring.
Improper insertion depth; no cold ring.
Excessive heating.

FIG. X2.3 Socket Fusion

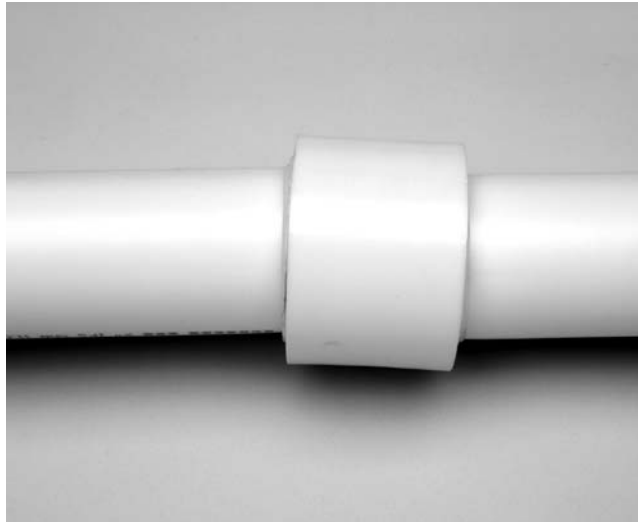

Unacceptable Visual Appearance

Misalignment.

FIG. X2.4 Socket Fusion

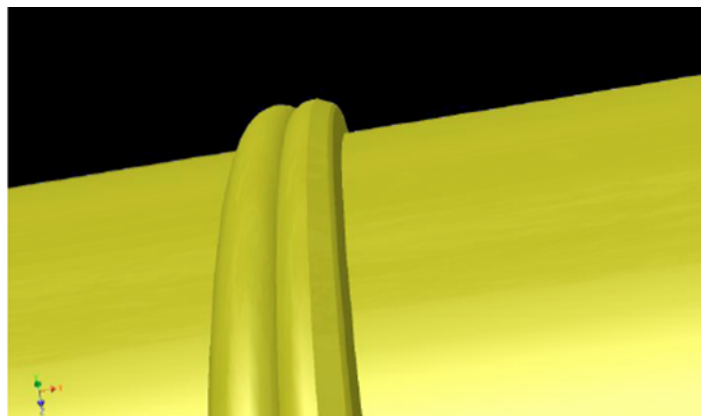

Acceptable Visual Appearances

Proper double roll-back bead.
Proper alignment.

FIG. X2.5 Butt Fusion



Unacceptable Visual Appearance

Incomplete face-off.

FIG. X2.6 Butt Fusion



Unacceptable Visual Appearance

Unacceptable concave melt appearance after heating.
Possible over-pressurization during the heat cycle.

FIG. X2.7 Butt Fusion



Unacceptable Visual Appearance

Improper “high-low” pipe alignment.
Visually mitered joint.

FIG. X2.8 Butt Fusion



Unacceptable Visual Appearance

Improper alignment in fusion machine—mitered joint.

FIG. X2.9 Butt Fusion



Unacceptable Visual Appearance

Contamination in joint.

FIG. X2.10 Butt Fusion



Acceptable Visual Appearance

Proper alignment, force and melt.
Proper surface preparation.

FIG. X2.11 Saddle Fusion Joint

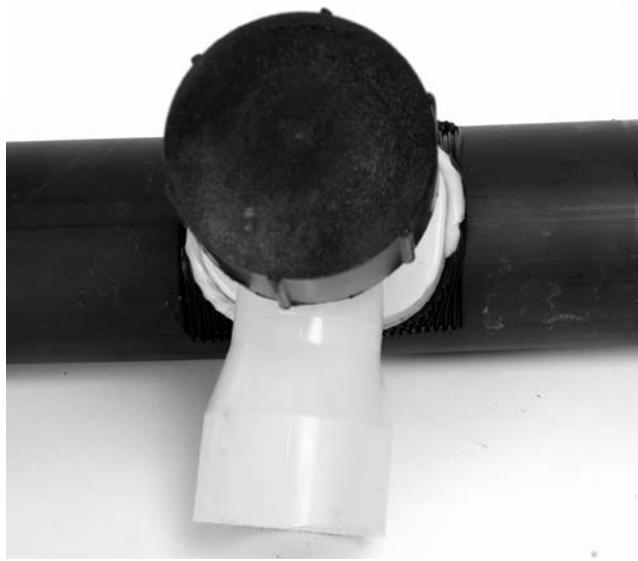

Unacceptable Visual Appearance

Improper alignment.
Fitting offset from melt pattern.

FIG. X2.12 Saddle Fusion Joint



Unacceptable Visual Appearance

Over-melt of fitting and main.
Possible over-pressurization of fitting on main.

FIG. X2.13 Saddle Fusion Joint



Unacceptable Visual Appearance

Under-melt of fitting and main.
Fitting offset from melt pattern.
Possible under-pressurization of fitting on main.

FIG. X2.14 Saddle Fusion Joint

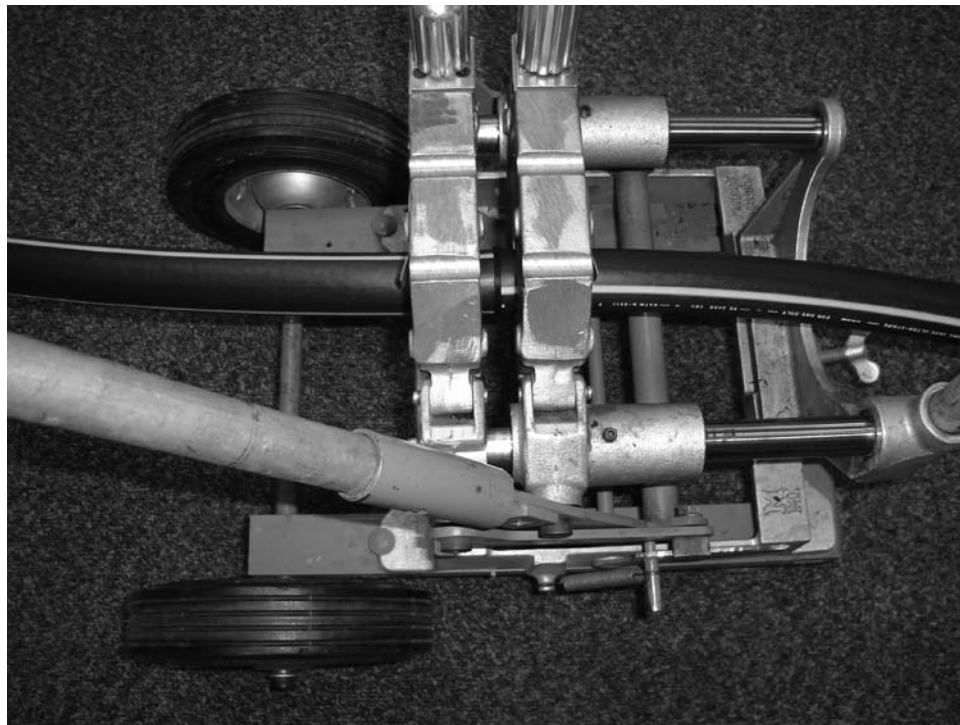

FIG. X2.15 Coiled Pipe Installation in Fusion Machine

X3. DETERMINING SADDLE FUSION FORCE IF LABEL IS NOT PRESENT

X3.1 When the saddle fusion fitting does not have a label to show the initial heat force (IHF) and the fusion force (FF), use the following formulas to determine the forces required.

$$IHF = L \times W - (0.785 \times d^2) \times 60 \quad (X3.1)$$

$$IHF = 0.785 \times (D^2 - d^2) \times 60 \quad (X3.2)$$

X3.2 Determining IHF and FF:

X3.2.1 IHF is determined by multiplying the area of the saddle fitting base by 60 psi, the initial interface pressure. For rectangular base saddle fittings, the fusion area is the base length times the base width less the area of the outlet hole. Base curvature and corner radii are ignored. For round base saddle fittings, the fusion area is the area of the base outside diameter less the area of the outlet hole. Base curvature is ignored.

where:

IHF = initial heat force, lb,

L = rectangular base length, in.,

W = rectangular base width, in.,

d = outlet hole inside diameter, in., and

D = round base outside diameter, in.

X3.2.2 *FF* is one-half of *IHF*:

$$FF = \frac{IHF}{2} \quad (X3.3)$$

X4. BEND BACK TESTING OF FUSED JOINTS

X4.1 It is possible to evaluate sample joints in order to verify the skill and knowledge of the fusion operator. Cut joints into straps, (see Fig. X4.1) and visually examine and test for bond continuity and strength. Bending, peeling, and elongation tests are useful for this purpose. These tests are generally conducted on smaller pipe sizes. For butt fusion test straps, limit the wall thickness of the pipe to 1 in. (25mm) to prevent possible injury in conducting the test. Visually inspect the cut joint for any indications of voids, gaps, misalignment of surfaces that have not been properly bonded. Bend each sample at the fusion joint with the inside of the pipe facing out until the ends touch. The inside bend radius should be less than the

minimum wall thickness of the pipe. In order to successfully complete the bend back, a vise may be needed. The sample must be free of cracks and separations within the fusion joint location. If failure does occur at the weld in any of the samples, then the fusion procedure should be reviewed and corrected. After correction, another sample fusion joint should be made per the new procedure and re-tested. Bend testing of pipes with a wall thickness greater than 1 in. (25mm) could be dangerous and should be done with an approved bending fixture that supports and contains the pipe during the test or with another approved procedure.

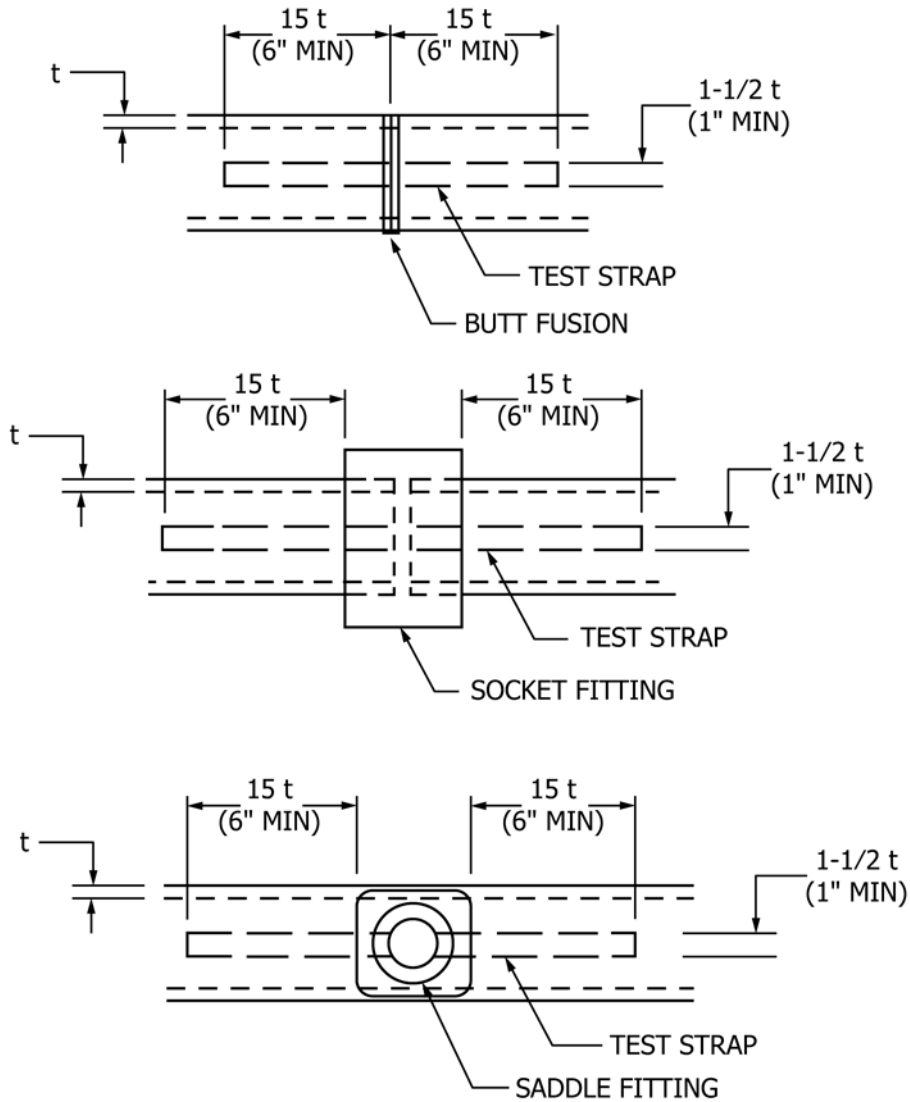

FIG. X4.1 Bent Strap Test Specimen

SUMMARY OF CHANGES

Committee F17 has identified the location of selected changes to this standard since the last issue (F2620-12) that may impact the use of this standard. (Approved Nov. 1, 2013.)

(1) 8.2.2 was revised.

Committee F17 has identified the location of selected changes to this standard since the last issue (F2620-11^{e1}) that may impact the use of this standard.

- (1) Sections 6.2, 7.2.2, and 7.2.4 were revised.
- (2) 7.2.7, and Note 4 revised.
- (3) 8.3.4, 8.3.5.1 revised.
- (4) 8.3.1 and Table 8.3.3 revised.
- (5) Table 3 revised.
- (6) Table 4 revised.

- (7) Note 8 revised.
- (8) Fig. 4 revised.
- (9) Sections 9.2.9, 9.4.1.1, 9.4.1.3, 9.4.2.1 revised.
- (10) Sections X1.6 and X1.7 added.
- (11) Fig. X2.5 revised.

ASTM International takes no position respecting the validity of any patent rights asserted in connection with any item mentioned in this standard. Users of this standard are expressly advised that determination of the validity of any such patent rights, and the risk of infringement of such rights, are entirely their own responsibility.

This standard is subject to revision at any time by the responsible technical committee and must be reviewed every five years and if not revised, either reapproved or withdrawn. Your comments are invited either for revision of this standard or for additional standards and should be addressed to ASTM International Headquarters. Your comments will receive careful consideration at a meeting of the responsible technical committee, which you may attend. If you feel that your comments have not received a fair hearing you should make your views known to the ASTM Committee on Standards, at the address shown below.

This standard is copyrighted by ASTM International, 100 Barr Harbor Drive, PO Box C700, West Conshohocken, PA 19428-2959, United States. Individual reprints (single or multiple copies) of this standard may be obtained by contacting ASTM at the above address or at 610-832-9585 (phone), 610-832-9555 (fax), or service@astm.org (e-mail); or through the ASTM website (www.astm.org). Permission rights to photocopy the standard may also be secured from the Copyright Clearance Center, 222 Rosewood Drive, Danvers, MA 01923, Tel: (978) 646-2600; <http://www.copyright.com/>