



Standard Specification for Heavy-Duty Ranges, Gas and Electric¹

This standard is issued under the fixed designation F2521; the number immediately following the designation indicates the year of original adoption or, in the case of revision, the year of last revision. A number in parentheses indicates the year of last reapproval. A superscript epsilon (ϵ) indicates an editorial change since the last revision or reapproval.

1. Scope

1.1 This specification covers heavy-duty ranges that use gas or electrical heat sources, or both, for cooking food in the commercial and institutional food service establishments.

1.2 The values stated in inch-pound units are to be regarded as standard. The values given in parentheses are mathematical conversions to SI units that are provided for information only and are not considered standard.

1.3 *This standard may involve hazardous materials, operations, and equipment. This standard does not purport to address all of the safety concerns, if any, associated with its use. It is the responsibility of the user of this standard to establish appropriate safety and health practices and determine the applicability of regulatory limitations prior to use.*

2. Referenced Documents

2.1 ASTM Standards:²

- D3951 Practice for Commercial Packaging
- F760 Specification for Food Service Equipment Manuals
- F1166 Practice for Human Engineering Design for Marine Systems, Equipment, and Facilities
- F1275 Test Method for Performance of Griddles
- F1496 Test Method for Performance of Convection Ovens
- F1521 Test Methods for Performance of Range Tops

2.2 ANSI Standards:³

- ANSI B1.1 Unified Inch Screw Threads (UN and UNR Thread Form)
- ANSI Z1.4 Sampling Procedures and Tables for Inspection by Attributes
- ANSI Z21.41/CSA 6.9 Quick-Disconnect Devices for Use With Gas Fuel Appliances

¹ This specification is under the jurisdiction of ASTM Committee F26 on Food Service Equipment and is the direct responsibility of Subcommittee F26.02 on Cooking and Warming Equipment.

Current edition approved April 1, 2014. Published May 2014. Originally approved in 2005. Last previous edition approved in 2009 as F2521 – 09. DOI: 10.1520/F2521-09R14.

² For referenced ASTM standards, visit the ASTM website, www.astm.org, or contact ASTM Customer Service at service@astm.org. For *Annual Book of ASTM Standards* volume information, refer to the standard's Document Summary page on the ASTM website.

³ Available from American National Standards Institute (ANSI), 25 W. 43rd St., 4th Floor, New York, NY 10036.

ANSI Z21.45 Flexible Connector of Other Than All-Metal Construction for Gas Appliances

ANSI Z83.11/CGA-1.8 Gas Food Service Equipment

2.3 NSF Standard:⁴

NSF/ANSI 4 Commercial Cooking, Rethermalization and Powered Hot Food Holding and Transport Equipment

2.4 NFPA Standard:⁵

NFPA 70/ANSI Z223 National Electrical Code

NFPA 54/ANSI Z223 National Fuel Gas Code

2.5 UL Standard:⁶

UL/ANSI 197 Commercial Electrical Cooking Appliances

2.6 Military Standards:⁷

MIL-STD-167/1 Mechanical Vibration of Shipboard Equipment (Type 1—Environmental and Type 2—Internally Excited)

MIL-STD-461 Requirements for the Control of Electromagnetic Characteristics of Subsystems and Equipment

MIL-STD-1399/300 Interface Standard for Shipboard Systems Section 300A Electric Power, Alternating Current

3. Terminology

3.1 Definitions of Terms Specific to This Standard:

3.1.1 *broiler, n*—open cast iron or steel grate on which food is laid, allowing highly directional intense heat under the grate to cook the food. Another type is an overfired heat source, using highly directional intense heat over the food.

3.1.2 *convection oven, n*—as used in this specification, a device that combines the function of circulating hot convection air in an enclosed cavity by means of a fan or blower, which is operated by an electric motor, for the purpose of baking or roasting food.

3.1.3 *cook-top electric element, n*—open coil electrical elements supported to withstand the weight of filled cooking utensils in direct contact with the burners.

⁴ Available from NSF International, P.O. Box 130140, 789 N. Dixboro Rd., Ann Arbor, MI 48113-0140.

⁵ Available from National Fire Protection Association (NFPA), 1 Batterymarch Park, Quincy, MA 02269-9101.

⁶ Available from Underwriters Laboratories (UL), Corporate Progress, 333 Pfingsten Rd., Northbrook, IL 60062.

⁷ Available from Standardization Documents Order Desk, DODSSP, Bldg. 4, Section D, 700 Robbins Ave., Philadelphia, PA 19111-5098, or from Acquisition Streamlining and Standardization Information System (ASSIST) located at <http://dsp.dla.mil>.

3.1.4 *French top, n*—sheathed electric burner with permanent cover over entire heating element; round and sealed to the range top to resist drips and splash.

3.1.5 *griddle, n*—device for cooking food by direct contact with a hot surface.

3.1.6 *heavy-duty range, n*—appliance used for pot or pan surface cooking, griddling, frying, broiling, steaming, baking, roasting, and reheating food products with a standard oven or convection oven. It is of the most durable construction, varying in size, offers increased heat input than medium (restaurant) or specialty ranges. Typical industry widths are 32 in. (812 mm), 34 in. (863 mm), and 36 in. (914 mm) for gas range tops and for electric ranges. The top cooking surface can be $\frac{1}{3}$, $\frac{2}{3}$, or full top options of any style noted. For purposes of convenience, nominal dimensions for each width will be used in this specification.

3.1.7 *hot top, n*—flat cast iron surface sometimes called a “boiling plate” or “uniform heat top” with heat transferred from gas burners or electric heating elements under the cooking surface where pots are set to warm or keep hot food contained in the utensil.

3.1.8 *open top gas burner, n*—also called grate top; has a cast iron or steel burner top that supports the pot above the gas burner.

3.1.9 *standard oven, n*—as used in this specification, a space where food is baked or roasted without recirculating air.

4. Classification

4.1 Type:

- 4.1.1 *Type I*—Electric range top with electric oven.
- 4.1.2 *Type I*—Electric range top with gas-fired oven.
- 4.1.3 *Type I*—Electric range top with storage base.
- 4.1.4 *Type II*—Gas-fired range top with gas-fired oven.
- 4.1.5 *Type II*—Gas-fired range top with electric oven.
- 4.1.6 *Type II*—Gas-fired range top with storage base.

Type I Style, Electric Ranges—Dimensions

4.2 Widths:⁸

- 4.2.1 32 in. (812 mm)
- 4.2.2 34 in. (863 mm)
- 4.2.3 36 in. (914 mm)

4.2.4 *Heights*—Typically 37 in. (939 mm) from floor to work surface.

4.2.5 *Depth*—Typically 37 in. (939 mm) to 41 in. (1040 mm).

4.3 Electrical Class:

- 4.3.1 *Class 1*—208 V, 60 Hz, 1 phase.
- 4.3.2 *Class 2*—208 V, 60 Hz, 3 phase.
- 4.3.3 *Class 3*—240 V, 60 Hz, 1 phase.
- 4.3.4 *Class 4*—240 V, 60 Hz, 3 phase.
- 4.3.5 *Class 5*—480 V, 60 Hz, 3 phase.
- 4.3.6 *Class 6*—120 V, 60 Hz, 1 phase.

4.3.7 *Class 7*—230 V, 50 Hz, 1 phase.

4.3.8 *Class 8*—400 V, 50 Hz, 3 phase.

4.3.9 *Class 9*—440 V, 60 Hz, 3 phase (shipboard use).

4.4 Cook Top Options

4.4.1 Electric Griddles:

4.4.1.1 $\frac{1}{3}$ top cover rated nominal 5 kW, $\frac{2}{3}$ other top options.

4.4.1.2 $\frac{1}{2}$ top cover rated nominal 10 kW, $\frac{1}{2}$ other top options.

4.4.1.3 Full top cover rated nominal 10 to 15 kW (Fig. A1.24).

4.4.1.4 $\frac{2}{3}$ top cover rated nominal 10 kW (Fig. A1.25).

4.4.2 *Electric Hot Tops (also known as Boiling Tops, Uniform Heat Tops)*—Specify with or without thermostat.

4.4.2.1 $\frac{1}{3}$ top cover rated nominal 5 kW, $\frac{2}{3}$ other top options.

4.4.2.2 $\frac{1}{2}$ top cover rated nominal 10 kW, $\frac{1}{2}$ other top options.

4.4.2.3 Full top cover rated nominal 10 to 15 kW (Fig. A1.21).

4.4.2.4 $\frac{2}{3}$ top cover rated nominal 10 kW (Fig. A1.22).

4.4.3 Open Top Electric Element Burner:

4.4.3.1 9½-in. (241-mm) diameter closed element (French top) full cook top rated nominal kW each (Fig. A1.23).

4.4.3.2 9½-in. (241-mm) diameter open element cook top rated at nominal kW.

4.4.4 *Additional Electric Range Cook Top Options for Electric Ranges*—Any combination of top cook devices in $\frac{1}{3}$, $\frac{1}{2}$, $\frac{2}{3}$, or full top coverage.

4.4.4.1 Three hot tops with or without thermostat.

4.4.4.2 Two hot tops and two 9-in. (229 mm) diameter French style electric burners.

4.4.4.3 Two hot tops and two 9-in. (229 mm) diameter open top element burners.

4.4.4.4 Six 9-in. (229 mm) diameter French style electric element burners.

4.4.4.5 Six 9-in. (229 mm) diameter open top element burners.

4.4.4.6 $\frac{1}{3}$, $\frac{1}{2}$, $\frac{2}{3}$, or full top coverage with griddle.

4.4.4.7 $\frac{1}{3}$ griddle, 4-top cook elements or hot tops.

4.4.4.8 $\frac{1}{2}$ griddle 2-top cook elements or hot tops

NOTE 1—All open top burners, French top burners, hot tops and griddles may have temperature controls.

4.4.4.9 With or without electric or gas oven (see 4.5 and 4.11).

4.5 Electric Ovens:

4.5.1 *Electric Standard Oven*—7.0 kW or greater.

4.5.2 *Electric Convection Oven*—7.0 kW or greater.

Type II Style, Gas-Fired Ranges—Dimensions

4.6 Widths:⁸

- 4.6.1 32 in. (812 mm)
- 4.6.2 34 in. (863 mm)
- 4.6.3 36 in. (914 mm) are typical

4.6.4 *Heights*—Typically 37 in. (939 mm) from floor to work surface.

⁸ Tops can be either a full top of one type of cook top such as a griddle or divided in sections with one or two or three cook top styles. Depending on range width, a full top and two sections for 32 and 34-in. (813 and 864-mm) widths and one, two, or three sections on 36-in. (914-mm) range tops.

4.6.5 *Depth*—Typically 37 in. (939 mm) to 41 in. (1040 mm).

4.7 *Power*:

- 4.7.1 Natural gas.
- 4.7.2 Propane.
- 4.7.3 Manufactured gas.
- 4.7.4 Other gases (see 5.2.2).

4.8 *Gas-Fired Cook Top Options*:

- 4.8.1 1/3 range top. (Fig. A1.13).
- 4.8.2 1/2 range top (Fig. A1.11).
- 4.8.3 2/3 range top (Fig. A1.14).
- 4.8.4 Full range top (Fig. A1.16).

NOTE 2—Griddle thickness may range from 3/8 to 1.0 in. (9.5 to 25 mm) and should be specified.

4.9 *Hot Tops (also known as Boiling Tops, Uniform Heat Tops)*:

- 4.9.1 1/3 range top and 2/3 other cook surface.
- 4.9.2 1/2 range top and 1/2 other cook surface (Fig. A1.2).
- 4.9.3 2/3 range top and 1/3 other cook surface.
- 4.9.4 Full range top (Fig. A1.1).
- 4.9.5 1/2 range top in horizontal top with open burners in front.

4.10 *Open Top Burners*:

- 4.10.1 1/3 range top and 2/3 other cook surface (Fig. A1.13).
- 4.10.2 1/2 range top and 1/2 other cook surface (Figs. A1.9-A1.12).
- 4.10.3 2/3 range top and 1/3 other cook surface (Fig. A1.14).
- 4.10.4 Full range top (Figs. A1.5-A1.8).
- 4.10.5 1/2 range top in horizontal top with open burners in front (Fig. A1.11).

4.11 *Ovens*:

- 4.11.1 *Gas-Fired Standard Oven*—22 000 to 50 000 Btu/h (6.45 to 14.66 KW).
- 4.11.2 *Gas-Fired Convection Oven*—22 000 to 40 000 Btu/h (6.45 to 11.73 KW).

4.12 *Additional Gas Range Cook Top Options for Gas Ranges*:

- 4.12.1 Graduated hot top or radial fin burners; 1, 2, or 3 concentric burner rings. Can be one center location on range top or two locations, or two locations to front with hot tops a back of range top (Figs. A1.1 and A1.2).
- 4.12.2 Graduated hot tops can be substituted for open top burners (Fig. A1.4) and have hot top plates in back.

5. Ordering Information

5.1 An order for a heavy-duty range(s) under this specification shall specify:

- 5.1.1 ASTM specification number and date of issue,
- 5.1.2 Quantity to be furnished,
- 5.1.3 Class,
- 5.1.4 Style (references to figures is helpful), and
- 5.1.5 Size.

5.2 Additionally, the following options should be reviewed for inclusion in the order:

5.2.1 When Federal/Military procurement(s) is involved, refer to the supplement pages.

5.2.2 *Type of Gas, as applicable*—Natural, propane, or when “other,” specify high heating value in BTU per hour, specific gravity, and composition of gas.

5.2.3 *Electrical Power Connection, if applicable*—Power cord with plug or conduit connection and size (that is, hard wired).

5.2.4 *Fan Speed (convection ovens only)*—Single speed or two speed.

5.2.5 *Type of Controls*—Electromechanical, solid state, or programmable/computer controlled.

5.2.6 *Interior Finish (convection ovens only)*—Porcelain enamel or stainless steel.

5.2.7 When specified, with a quick-disconnect gas supply, an approved quick disconnect (socket and plug) conforming to ANSI Z21.41, and a flexible metal connector conforming to ANSI Z21.45 and consisting of a male pipe thread fitting on one end and a union with female thread on the opposite end shall be provided with the convection oven.

5.2.8 Other than the manufacturer’s standard, commercial and domestic packaging is required. Specify packaging requirements.

5.2.9 When specified, a certification to ensure that samples representing each lot have been either tested or inspected as directed and the requirements have been met. When specified, a copy of the certification or test results, or both, shall be furnished to the purchaser.

5.2.10 When specified, additional options such as wire shelves, casters, oven stand, wash-down hose assembly, and faucets shall be provided.

5.2.11 Manufactured gas or overseas specified gas (may be other than CE gasses) are to be considered to be a special requirement and, if available, may be additional cost and may include a non-standard gas train.

5.2.12 Griddles shall be hot-rolled steel.

5.2.13 When specified, surface finish other than manufacturer finish shall be provided.

5.2.14 Hot tops can be hot-rolled steel.

6. Materials and Manufacture

6.1 *General*—Convection ovens shall conform to the applicable documents listed in Section 2. Materials used shall be free from defects which would affect the performance or maintainability of individual components or of the overall assembly. Materials not specified in this specification shall be of the same quality used for the intended purpose in commercial practice. Unless otherwise specified in this specification, all equipment, material, and articles incorporated in the work covered by this specification are to be new or fabricated, using materials produced from recovered materials to the maximum extent possible without jeopardizing the intended use. None of the above shall be interpreted to mean that the use of used or rebuilt products is allowed under this specification unless otherwise specified.

6.2 *Hardware and Fittings*—Unless otherwise specified (see Section 4), all hardware and fittings shall be corrosion resistant or suitably processed to resist corrosion in accordance with the manufacturer’s standard practice.

6.3 *Threaded Parts*—All threaded parts shall conform to ANSI B1.1.

6.4 *Service Connections*—Provisions for service shall be provided in the back or bottom of the convection oven. Access to shut off gas valves and the like shall be from the front of the range.

6.5 *Electrical Characteristics*—All electric elements shall be designed for operation on nominal voltage ratings, frequency, and phases as specified by electrical Class (see 4.3). Access to circuit breakers, fuses, and the like shall be from the front of the range.

6.6 *Oven Door*—Provisions shall be made to limit dripping when opened. Gasket, when provided, shall be replaceable without the use of tools of any type.

6.7 *Oven Fan and Baffle*—A motor-operated fan or blower shall be provided to ensure forced air circulation within the oven cavity. A single-speed or two-speed motor shall operate fan. Air baffle may be provided to maintain uniformity of temperature within the oven cavity. When provided, the baffle shall be removable with the use of simple tools such as a screwdriver and pliers.

7. Oven Controls

7.1 All ranges shall be provided with means to regulate the oven interior temperature and cook top burner heat.

7.2 The temperature regulating device shall be calibrated to maintain the temperature of air inside the oven within a tolerance of 25°F (13.9°C) from the set point.

7.3 A timer to monitor the cook time may be provided. When specified, it shall signal the end of set cook time with an audible alarm and prevent continued heating of the air inside the oven cavity.

7.4 A cook timer, when provided, shall operate within a tolerance of:

7.4.1 2 min, for settings to 30 min.

7.4.2 3 min, for settings from 30 min to 2 h.

7.4.3 4 min, for settings greater than 2 h.

7.5 When control knobs, switches, and indicating lights are located on the front panel, they shall be recessed or otherwise protected from inadvertent changes or damage.

7.6 Each oven shall be provided with a switch that shall de-energize the fan or blower circuit when door is opened in any operating mode.

7.7 *Heating Elements*—The electric convection ovens shall have heating elements arranged so that they will not intrude in the cooking zone. Heating elements shall be readily accessible for repair or replacement. The terminals of the heating elements shall project a sufficient distance to permit easy access to the connections.

7.8 *Gas Valves*—Regulates gas flow to main burners.

8. Design and Construction

8.1 *General*—Griddles and accessories shall conform to National Standards references in Item 2 as applicable.

8.2 *Service Connections*—Provisions for power service shall be provided in the back or bottom of the range.

8.3 *Electrical Characteristics*—All electric griddles shall be designed for operation on nominal voltage ratings, Hz, and phases as specified by electrical class.

8.4 *Griddle Surface*—The griddle surface shall not be porous, pitted, cracked, or distorted.

8.5 *Controls*—The temperature of each griddle section shall be controlled by a temperature regulating device or thermostat. If switches and thermostats are located on the front panel, they shall be recessed or otherwise protected from inadvertent changes or damage. The temperature controlling device or thermostat shall be calibrated to maintain the surface temperature on each section at $\pm 25^\circ\text{F}$ (13.9°C). For areas adjacent to the splash guards, the surface temperature tolerance shall not vary more than 30°F (16.7°C).

8.6 *Heating Elements*—The electric griddles shall have heating elements arranged so that different areas of the griddle may be controlled independently. A minimum of one heating element shall be furnished for each linear foot (305 mm) of the griddle plate. The elements shall be the enclosed coil type and shall be attached securely to the bottom of the griddle plate. The bottom of the heating elements shall be enclosed by a heat-insulating pad or by a system of heat-reflecting baffles. Both methods shall be designed to isolate the heating elements by reducing the amount of heat radiated downwards. When an insulating pad is used, it shall be fire resistant and suitable for the temperatures generated in this area. Heating elements shall be accessible readily for repair or replacement.

9. Performance Requirements

9.1 Performance testing, when required, shall be tested in accordance with Test Method F1496, Ovens; Test Methods F1521, Ranges; and Test Method F1275, Griddles.

10. Sampling

10.1 When specified in the contract or purchase order, sampling for the inspection and tests contained in the main body of this specification shall be performed in accordance with ANSI Z1.4.

11. Test Methods

11.1 *Oven Thermostat Test*—When required, shall be tested in accordance with applicable sections of Test Method F1496.

12. Inspection

12.1 The range ready for shipment shall be measured and inspected by the manufacturer for compliance with 5.2.9 .

13. Product Marking

13.1 Each range shall be provided with an identification plate in compliance with all third party testing agencies as applicable.

14. Manuals

14.1 Each range shall be furnished with an installation and operating instructions manual. Manual shall comply with Specification F760.

15. Packaging and Package Marking

15.1 The range shall be packaged and packed in accordance with the manufacturer’s standard commercial packaging. The package shall be marked, showing the name of the product, model number, serial number, and manufacturer’s name. When specified, packaging shall be in accordance with the requirements of Practice **D3951**.

16. Keywords

16.1 convection oven; food service equipment; French tops; griddle; heavy-duty range; hot tops (boiling plates)

SUPPLEMENTARY REQUIREMENTS

FEDERAL/MILITARY PROCUREMENT

Where provisions of this supplement conflict with the main body, this supplement shall prevail.

S1. Manual

S1.1 A manual complying with Specification **F760** and supplement shall be provided.

S2. First Article Inspection

S2.1 When required, the first article inspection shall be performed on one unit. The first article may be either a first production item or a standard production item from the supplier’s current inventory, provided the item meets the requirements of the specification and is representative of the design, construction, and manufacturing technique applicable to the remaining items to be furnished under the contract.

S3. Data Nameplate

- S3.1 A nameplate shall contain the following:
 - S3.1.1 National Stock Number (NSN), and
 - S3.1.2 Government approved manual number.

S4. Part Identifying Number

S4.1 The following part identifying numbering procedure is for government purposes and does not constitute a requirement for the contractor. These classes are the same as those in Section 4. The PINs to be used for items acquired to this ASTM specification are as follows:

ASTMFXXXX	1	2	3
Specification No. _____	Type _____		
	Class _____		
	Size _____		

- S4.2 *Type I*—Floor mounted with oven on legs or casters.
- S4.3 *Type II*—Counter class (modular).
- S4.3 *Type III*—Floor mounted with storage on legs or casters.

S5. Preservation, Packaging, and Package Marking

S5.1 When other than normal commercial practice or conformance to Practice **D3951** is desired, the preservation, packaging, and package marking requirements shall be stated in the purchase order or contract.

S6. Naval Shipboard Requirements

S6.1 *Electromagnetic Compatibility*—When specified, electric heavy-duty ranges all be designed and equipped for electromagnetic compatibility in accordance with MIL-STD-

461. The contractor shall furnish written certification that the equipment meets the emission and susceptibility requirements when tested in accordance with the requirements of MIL-STD-461.

S6.2 *Inclined Operation*—When specified, the units shall operate satisfactorily, along with no spillage of product, when the heavy duty range is inclined for 30 s at an angle of 30° for submarines, and 15° for surface ships each side of the vertical in each of two vertical planes at right angles to each other. This test shall be run for 30 complete cycles in each of the two vertical planes.

S6.3 *Environmental Suitability*—Heavy-duty ranges shall be capable of withstanding the ship’s vibration and motion. When specified, the unit, under normal operating conditions, shall be tested in accordance with MIL-STD-167/1, Type I equipment. The unit shall be secured to the test machine in the same manner that it will be secured on the board ship. The unit shall operate without malfunction.

S6.4 *Access*— Unless otherwise specified, units for naval surface vessels shall pass through a 26-in. (66-cm) wide and 66-in. (168-cm) high shipboard hatch without major disassembly. Equipment for submarines shall pass through a 25-in. (64-cm) diameter circular hatch. Major disassemble of a range intended for submarine use is permissible.

S6.5 *Service Access*—This unit shall be designed for access of all utility connections and major serviceable components from the front of the unit.

S6.6 *Power*—Unless otherwise specified, equipment shall be supplied in 440 Vs, 60 Hz, 3-phase, 3-wire ungrounded system in accordance with MIL-STD-1399/300.

S6.7 *High Voltage Label*—On equipment rated 440 VAC or higher, a “Danger High Voltage” label shall be affixed to the equipment outer case assembly, on or adjacent to each service access cover adjacent to one of the fasteners which secure the cover. The warning label shall also be placed near the high voltage components inside the equipment. The label shall include, but is not limited to:

- S6.7.1 A warning of high voltage;
- S6.7.2 The power supply must be disconnected before servicing;
- S6.7.3 Access covers must be in place during use; and
- S6.7.4 Service should be done by authorized personnel.

S6.8 *Mounting*— Heavy-duty ranges for shipboard shall be provided with four stainless steel legs suitable for bolting to the ship deck.

S6.9 *Interior Oven Finish*—The interior finish of the oven shall be stainless steel or removable liners, fabricated from stainless steel.

S6.10 *Human Factors Criteria*—Human factors engineering criteria principles, and practices as defined in Practice F1166, shall be used in the design.

S6.11 *Instruction Plate*—An instruction plate shall include instruction for startup, operation, and shutdown and shall be located at a clearly visible location in front of the convection oven.

S6.12 *Manufacturer’s Certification*—If the manufacturer has successfully furnished the same equipment on a previous contract within the past 3 years, further inspection will not be required. The manufacturer shall certify in writing that the

equipment to be furnished is the same as that previously furnished and approved and that no major design changes have been made to the equipment.

S6.13 *Wiring*—Suitable shields or baffles shall be installed to prevent wiring from hanging into areas in which personnel can access or areas in which wires can come in contact with removable parts such as crumb drawers and grease troughs.

S6.14 *Drawers and Receptacles*—When provided, griddle tops shall have grease front troughs that lead to a collecting receptacle drawer such that the collection drawer can be accessed from the front of the range. A positive latch shall be provided for grease drawers and crumb drawers to prevent opening and spillage.

S6.15 *Grab Rod, Oven Latches, Pot Rails*— Shipboard ranges shall be provided with 1-in. (25-mm) round grab bar attached across the entire range front. Pot rails for hot tops and oven door latches shall be provided.

ANNEX

(Mandatory Information)

A1. PICTORIAL COOK TOP CONFIGURATIONS

Gas-Fired Range Top Configuration and Sections

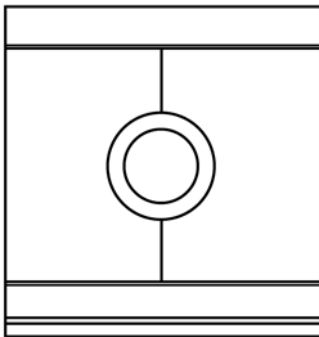

NOTE 1—Typical inner burner rated at 11 000 Btu/h (3.23 KW), middle burner rates at 14 000 Btu/h (4.11 KW), outer burner rated at 25 000 Btu/h (7.33 KW).

FIG. A1.1 Radial Fin Range Top Typically Constructed with Three Burners

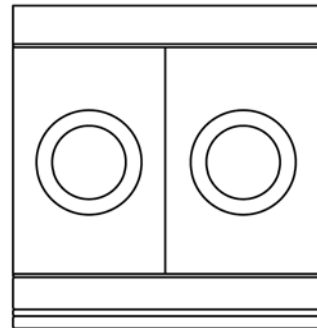

NOTE 1—Inner burner rated at 11 000 Btu/h (3.23 KW), outer burner at 25 000 Btu/h (7.33 KW).

FIG. A1.2 Radial Fin Range Top Constructed with Two Burners in Each Section

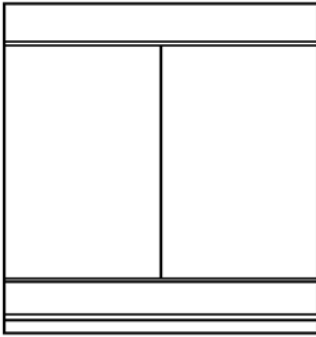

NOTE 1—Typical rating of two 32 000 to 40 000-Btu/h (9.38 to 11.73 KW) burners.

FIG. A1.3 Two-Section Hot Top or (Boiling Top)

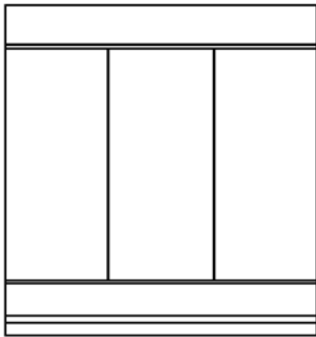

NOTE 1—Typical burners rated from 20 000 to 40 000 Btu/h (5.87 to 11.73 KW) each.

FIG. A1.4 Three-Section Hot Top (Boiling Top)

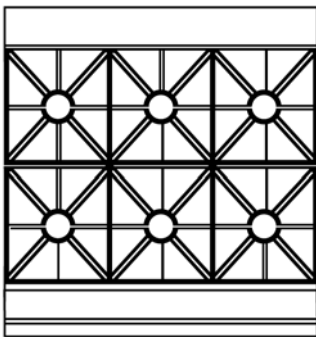

NOTE 1—Each burner typically rated from 20 000 to 40 000 Btu/h (5.87 to 11.73 KW).

FIG. A1.5 Three-Section Top Sections of Six Open Top Burners

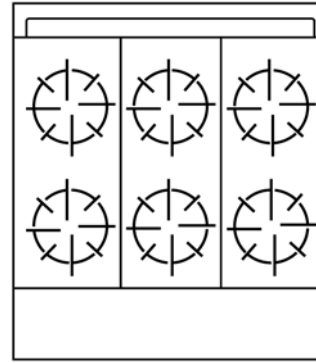

NOTE 1—Open top burners rated from 20 000 to 40 000 Btu/h (5.87 to 11.73 KW).

FIG. A1.6 Three-Section Open Top Burners with Alternate Style Burners and Grates

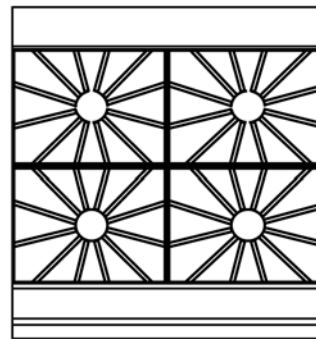

NOTE 1—Each burner typically rated from 20 000 to 40 000 Btu/h (5.87 to 11.73 KW).

FIG. A1.7 Four Open Top Burner Range Top

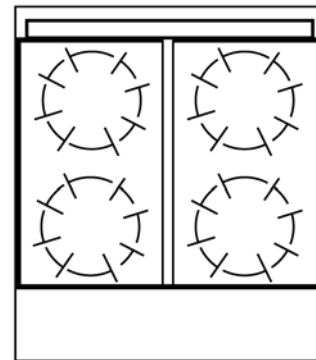

NOTE 1—Open top burners rated from 17 500 to 45 000 Btu/h (5.13 to 13.20 KW).

FIG. A1.8 Four Open Top Burners with Alternate Style Burners and Grates

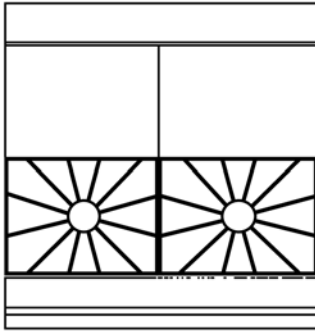

NOTE 1—Two hot top burners rated from 15 000 to 40 000 Btu/h (4.0 to 11.73 KW). Two open top burners rated from 20 000 to 40 000 Btu/h (5.87 to 11.73 KW).

FIG. A1.9 Two-Section Combination Style of Two Hot Tops and Two Open Top Burners

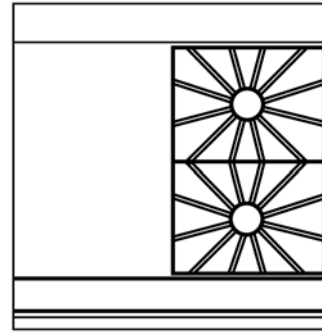

NOTE 1—Open top burners each rated from 20 000 to 45 000 Btu/h (5.87 to 13.20 KW). Griddle rated from 20 000 to 40 000 Btu/h (5.87 to 11.73 KW). Sections may be reversed.

FIG. A1.12 Two-Section Vertical Top Side Hot Top or Griddle

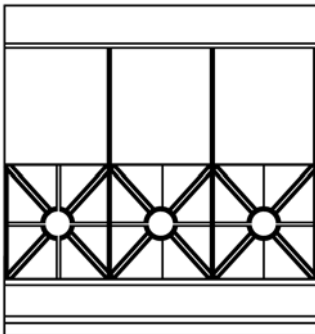

NOTE 1—Three open top burners rated from 20 000 to 40 000 Btu/h (5.87 to 11.73 KW) each section. Three hot top burners rated from 20 000 to 40 000 Btu/h (5.87 to 11.73 KW) each.

FIG. A1.10 Three-Section Combination Style of Three Hot Top and Three Open Top Burners

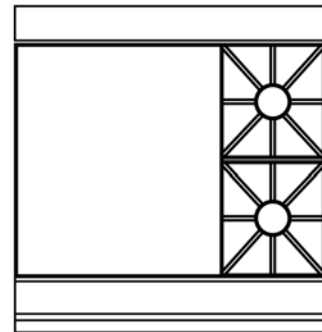

NOTE 1—Open top burners typically rated from 20 000 to 45 000 Btu/h (5.87 to 13.20 KW) each. Griddle rated from 20 000 to 40 000 Btu/h (5.87 to 11.73 KW) each section.

FIG. A1.13 Three-Section Vertical View; Two Single Open Top Section; Two-Section Griddle

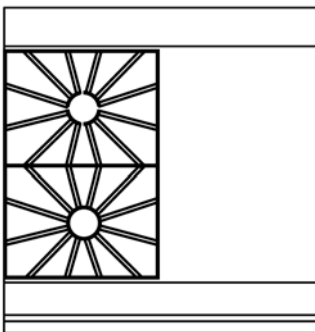

NOTE 1—Open top burners rated from 20 000 to 45 000 Btu/h (5.87 to 13.20 KW). Hot top rated from 20 000 to 40 000 Btu/h (5.87 to 11.73 KW).

FIG. A1.11 Two-Section Vertical Top Using Two Open Top Burners and Either Hot Top or Griddle

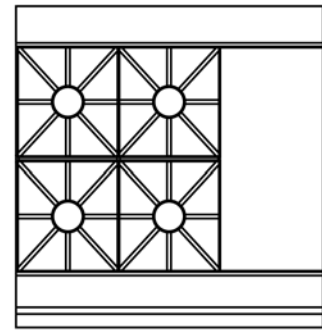

NOTE 1—Three-section vertical view with open top rated from 20 000 to 40 000 Btu/h (5.87 to 11.73 KW). Single section hot top or griddle rated from 20 000 to 40 000 Btu/h (5.87 to 11.73 KW).

FIG. A1.14 Three-Section Vertical View; Four Open Top Burners and One Griddle Section; Open Burners and One Two-Section Griddle

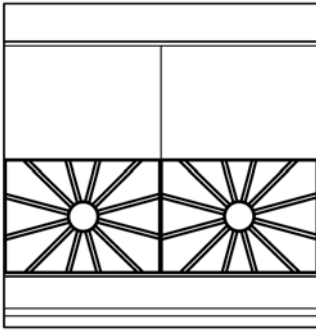

NOTE 1—Open top burners each rated from 20 000 to 45 000 Btu/h (5.87 to 13.20 KW). Hot tops rated 20 000 to 40 000 Btu/h (5.87 to 11.73 KW) each half. Hot tops can be one or two sections.

FIG. A1.15 Horizontal Range Top with 1/2 Open Top Burners in Front and Hot Top Open Top Burners Side by Side in Front; Hot Top Sections in Rear

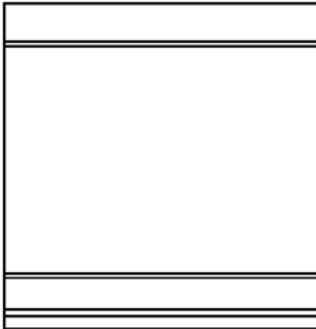

NOTE 1—Can have two or three burners per section with burners rated from 20 000 to 40 000 Btu/h (5.87 to 11.73 KW) each burner.

FIG. A1.16 Full-Top Griddle

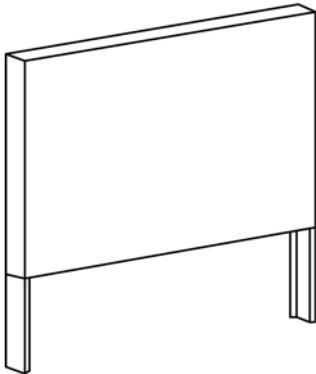

NOTE 1—Can be 60 to 72 in. (1524 to 1829 mm) high and from 24 to 36 in. (610 to 914 mm) wide.

FIG. A1.17 Range Splash Back; Single Splash Back

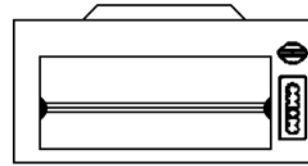

NOTE 1—Available with full-size gas or electric ranges.

FIG. A1.18 Typical Cheesemelter or Unit Broiler

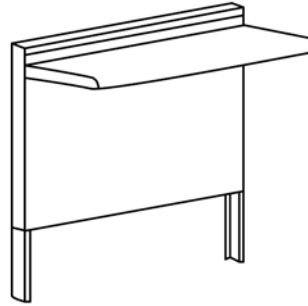

NOTE 1—Can be from 60 to 72 in. (1524 to 1829 mm) high. Back widths to fit range.

FIG. A1.19 Range Splash Back with Single Shelf

Electrical Range Top Configuration and Sections

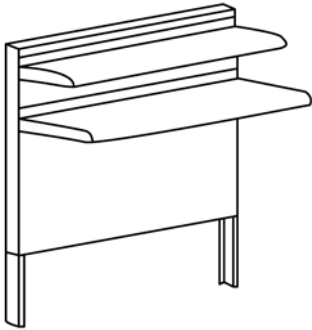

NOTE 1—Back to fit range widths.

FIG. A1.20 Range Splash Back with Double Shelves

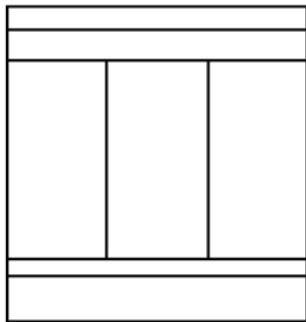

NOTE 1—May have thermostat controls.

FIG. A1.21 Electric Three-Section Range with Hot Tops

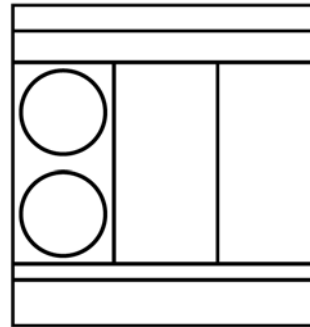

FIG. A1.22 Electric Three-Section Range Top with Two Open Element or French Type Elements and Two Hot Tops

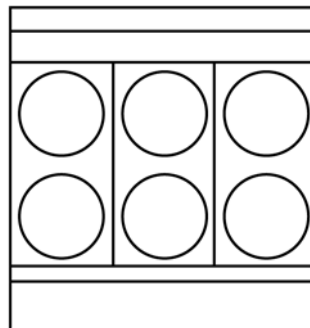

FIG. A1.23 Electric Three-Section Range Top with Six Open Element or French

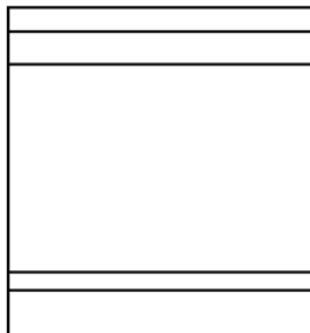

FIG. A1.24 Full Range Top Electric Style Burners Griddle

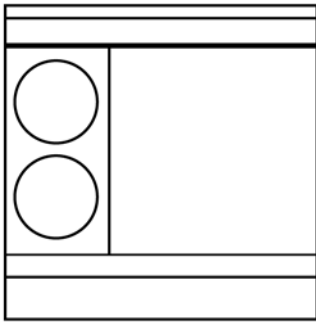

FIG. A1.25 Electric Three-Section Range Top with Two Electric Open Elements or French Style Burners and Griddle



FIG. A1.26 Sectional Range top with Open Top Burners or French Elements



FIG. A1.27 Typical Waldorf Installation

APPENDIX

(Nonmandatory Information)

X1. ADDED FEATURES

X1.1 Typically, features are added to basic models at an additional cost. Any options that are required can be written into the procurement contract as desired.

X1.2 *Construction and Accessories Available but Not Covered in this Specification:*

X1.2.1 This specification does not purport to address all of the sizes or gas and electric ratings that may be available, but it is an overview of the most common sizes used in the industry today. Most manufacturers provide additional range, Type III tops of 12 in. (305 mm), 18 in. (457 mm), or of a width equal to a full range top gas or electric section (Fig. A1.26). The top styles are described in this Specification, while ovens are not provided with these modular or expando tops. Modular or counter range tops Type II are identical in top constructions and rating.

X1.2.2 Additional features not described in this specification are: unit broilers mounted over the range top (see Fig. A1.18); working or false flues or splash backs of varying heights from 4 to 22 in. (101.6 to 558.8 mm) (see Fig. A1.17);

and tall back splash, when ordered, may have one or two shelves (see Figs. A1.19 and A1.20).

X1.2.3 Special construction of Heavy Duty Ranges in conjunction with other equipment can be ordered as separate appliances with one large top and sides covering spaces between equipment such as shown in Fig. A1.27.

X1.2.4 Additional standards can be available from the following organizations:

X1.2.4.1 *ANSI*—American National Standards Institute, 25. W 43rd St., 4th Floor, New York, NY 10036

X1.2.4.2 *ASTM*—100 Barr Harbor Drive, West Conshohocken, PA 19428

X1.2.4.3 *NFPA*—National Fire Protection Association, 1 Batterymarch Park, Quincy, MA 02269-9101

X1.2.4.4 *NSF*—NSF International, P.O. Box 130140, Ann Arbor, MI 48113-0140

X1.2.4.5 *UL*—Underwriters Laboratories, Inc., 333 Pfingsten Rd., Northbrook, IL 60062

X1.2.4.6 *Government Documents*—Standardization Documents Order Desk, 700 Robbins Ave., Building #4 - Section D, Philadelphia, PA 19222-5094

ASTM International takes no position respecting the validity of any patent rights asserted in connection with any item mentioned in this standard. Users of this standard are expressly advised that determination of the validity of any such patent rights, and the risk of infringement of such rights, are entirely their own responsibility.

This standard is subject to revision at any time by the responsible technical committee and must be reviewed every five years and if not revised, either reapproved or withdrawn. Your comments are invited either for revision of this standard or for additional standards and should be addressed to ASTM International Headquarters. Your comments will receive careful consideration at a meeting of the responsible technical committee, which you may attend. If you feel that your comments have not received a fair hearing you should make your views known to the ASTM Committee on Standards, at the address shown below.

This standard is copyrighted by ASTM International, 100 Barr Harbor Drive, PO Box C700, West Conshohocken, PA 19428-2959, United States. Individual reprints (single or multiple copies) of this standard may be obtained by contacting ASTM at the above address or at 610-832-9585 (phone), 610-832-9555 (fax), or service@astm.org (e-mail); or through the ASTM website (www.astm.org). Permission rights to photocopy the standard may also be secured from the Copyright Clearance Center, 222 Rosewood Drive, Danvers, MA 01923, Tel: (978) 646-2600; http://www.copyright.com/