



Designation: F2438 – 04 (Reapproved 2017)

Standard Specification for Oil Spill Response Boom Connection: Slide Connector¹

This standard is issued under the fixed designation F2438; the number immediately following the designation indicates the year of original adoption or, in the case of revision, the year of last revision. A number in parentheses indicates the year of last reapproval. A superscript epsilon (ϵ) indicates an editorial change since the last revision or reapproval.

1. Scope

1.1 This specification covers design criteria requirements, design geometry, material characteristics, and desirable features for oil spill response boom slide connections. These criteria are intended to define minimum mating characteristics and are not intended to be restricted to a specific configuration.

1.2 The specification defines the geometry required to mate with typical Universal slide connectors or Specification F962 connectors with web thickness up to 0.3 in. Some very heavy-duty or PVC connectors may exceed this dimension and not be compatible.

1.3 The values stated in inch-pound units are to be regarded as standard. No other units of measurement are included in this standard.

1.4 *This standard does not purport to address all of the safety concerns, if any, associated with its use. It is the responsibility of the user of this standard to establish appropriate safety and health practices and to determine the applicability of regulatory limitations prior to use.*

1.5 *This international standard was developed in accordance with internationally recognized principles on standardization established in the Decision on Principles for the Development of International Standards, Guides and Recommendations issued by the World Trade Organization Technical Barriers to Trade (TBT) Committee.*

2. Referenced Documents

2.1 *ASTM Standards:*²

F818 Terminology Relating to Spill Response Booms and Barriers

F962 Specification for Oil Spill Response Boom Connection: Z-Connector

F1523/F1523M Guide for Selection of Booms in Accordance With Water Body Classifications

¹ This specification is under the jurisdiction of ASTM Committee F20 on Hazardous Substances and Oil Spill Response and is the direct responsibility of Subcommittee F20.11 on Control.

Current edition approved May 1, 2017. Published May 2017. Originally approved in 2004. Last previous edition approved in 2010 as F2438 – 04(2010). DOI: 10.1520/F2438-04R17.

² For referenced ASTM standards, visit the ASTM website, www.astm.org, or contact ASTM Customer Service at service@astm.org. For *Annual Book of ASTM Standards* volume information, refer to the standard's Document Summary page on the ASTM website.

3. Material Characteristics

3.1 End connector and locking pin materials shall be corrosion resistant in seawater and such other environments as the intended service may require. If dissimilar metals are used, care shall be used in design to avoid galvanic corrosion.

3.2 Any material is acceptable for construction of the boom connector provided consideration is given to such factors as weight, mechanical strength, chemical resistance, flexibility, and conditions of the environment in which it is to be used.

4. Design Requirements

4.1 The minimum tensile strength of a boom-to-boom connection shall equal or exceed the minimum fabric tensile strength specified in Table 1 of Guide F1523/F1523M.

4.2 The connector design shall ensure distribution or transfer of the tension member loads from one boom section to the next through or around the end connector in such a manner that the integrity of the joint is not broken at the fabric connection or any supplemental tension member connection(s).

4.3 The connector opening shall be to the right when looking at the top of the connector as shown in Fig. 1.

4.4 The connector or adapter shall not take more than 0.04 in. permanent set when a 250-lb load, distributed over 3 in., is applied. The load shall be applied at the location that results in maximum deflection and shall be resisted by supports placed ½ in. from each end as shown in Fig. 2.

4.5 An end connector shall be long enough to be compatible with the particular boom of which it is a part and not be a limiting member as to the functional freeboard or draft of the membrane.

4.6 The design shall include a tethered, 3/8 in. diameter, self-locking pin, conforming to the dimensional criteria shown in Fig. 3, to resist vertical movement of joined connectors in relation to each other.

4.6.1 The pin's overall length shall be minimized and its ends rounded or chamfered so as to minimize wear and tear on adjacent stored booms or injury to boom handlers.

4.6.2 The pin's spring shall be captured or locked to the pin assembly and shall exert a force on the toggle of between 16 and 22 lbs when connectors are assembled.

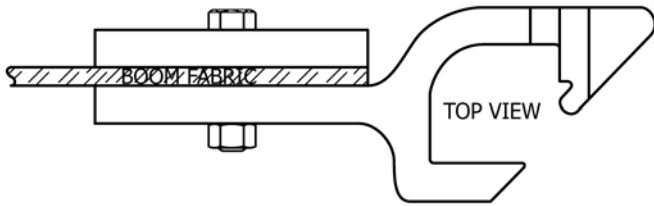

NOTE 1—All drawings in this document are generic and are not intended to depict any manufacturer’s specific product.

FIG. 1 Connector Orientation

4.6.3 When the pin’s spring is fully compressed, there shall be a clearance of $\frac{1}{8}$ in. between the short end of the toggle and the mated connector as shown in Fig. 3.

4.6.4 The toggle shall turn freely and shall latch in either direction.

4.6.5 The assembly shall incorporate a ring or lanyard loop of a minimum $1\frac{1}{2}$ in. diameter for the convenience of pulling the pin from the boom connectors.

4.6.6 The pin/lanyard assembly shall resist a tensile load of 180 lb, placed upon the closed toggle by the test fixture to which the pin’s lanyard is attached, without deformation.

4.6.7 One pin/lanyard assembly shall be furnished with, and connected to, each end connector or adapter.

4.6.8 Each lanyard shall be long enough to allow the pin to be inserted into any pinhole in the connector.

4.7 Pinholes, designed to accommodate the $\frac{3}{8}$ in. diameter self-locking pin, shall be incorporated at the design water line (DWL) and, if required, a location as determined in 4.7.1 or 4.7.2 and shown in Fig. 4.

4.7.1 For any connector with 7.0 to 12.9 in. of connector material below the DWL pinhole, a second pinhole shall be located 6.000 ± 0.015 in. below the DWL pinhole as shown in Fig. 4(b).

4.7.2 For any connector with 13.0 in. or more of connector material below the DWL pinhole, a second cross-pin hole shall be located 12.000 ± 0.015 in. below the DWL pinhole as shown in Fig. 4(c).

4.8 Where one half of a connector set mates with one having the geometry defined herein but is of other dimensions, it shall:

- 4.8.1 Possess adequate mechanical strength.
- 4.8.2 Minimize oil leakage.
- 4.8.3 Be sexless (neither male/female).
- 4.8.4 Be full height of boom of which it is a part.
- 4.8.5 Not impair stability of the boom.
- 4.8.6 Require no special tools for assembly.
- 4.8.7 Not reduce freeboard.

5. Significance and Use

5.1 The general design geometry herein defined applies to both a separate adaptor accessory mating two booms of different geometry as well as boom end connectors (see Terminology F818).

5.2 Interconnectability is intended to facilitate mating of oil spill response booms of various sizes, strengths, design, and manufacture.

5.3 The use of this general design geometry in no way guarantees the effective performance of the linked boom sections, since each boom’s design and the environmental conditions at each incident govern overall performance.

6. Desirable Features

6.1 Desirable features of the connector design include the following:

- 6.1.1 Speed and ease of connection.
- 6.1.2 Light weight.
- 6.1.3 Connectable in the water.
- 6.1.4 Readily cleaned of sand and debris.
- 6.1.5 Inherently safe to personnel.
- 6.1.6 Easy to install or replace.

7. Keywords

- 7.1 boom; boom connection; oil spill response

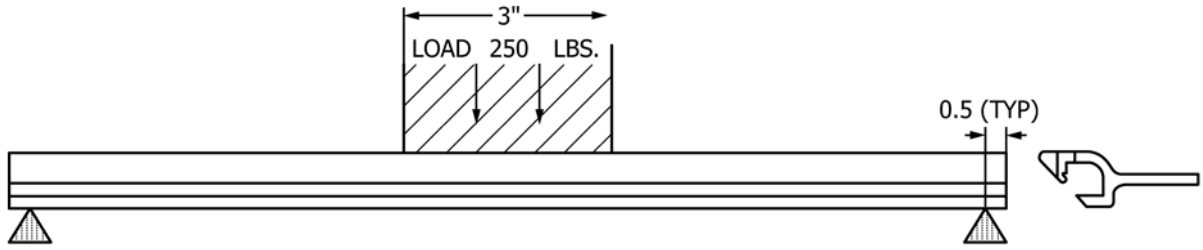

FIG. 2 Slide Connector/Adapter

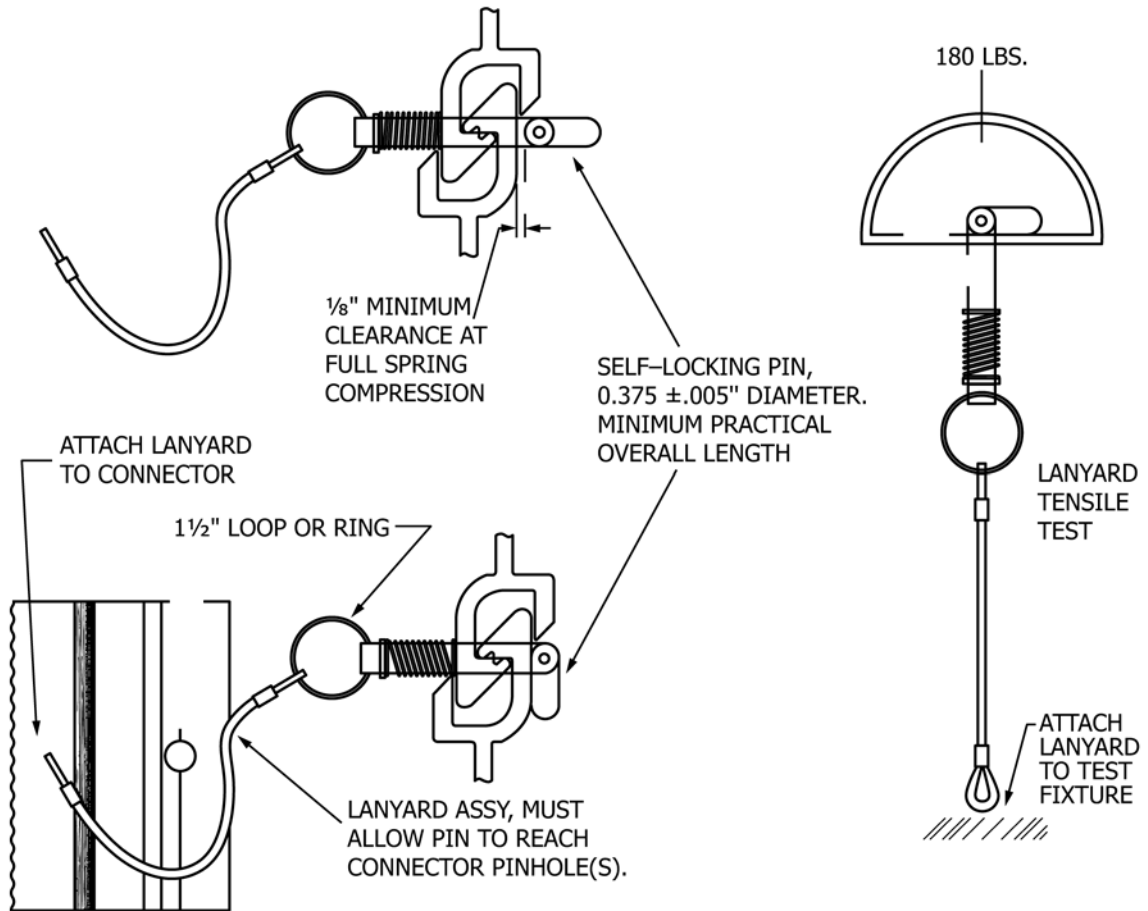
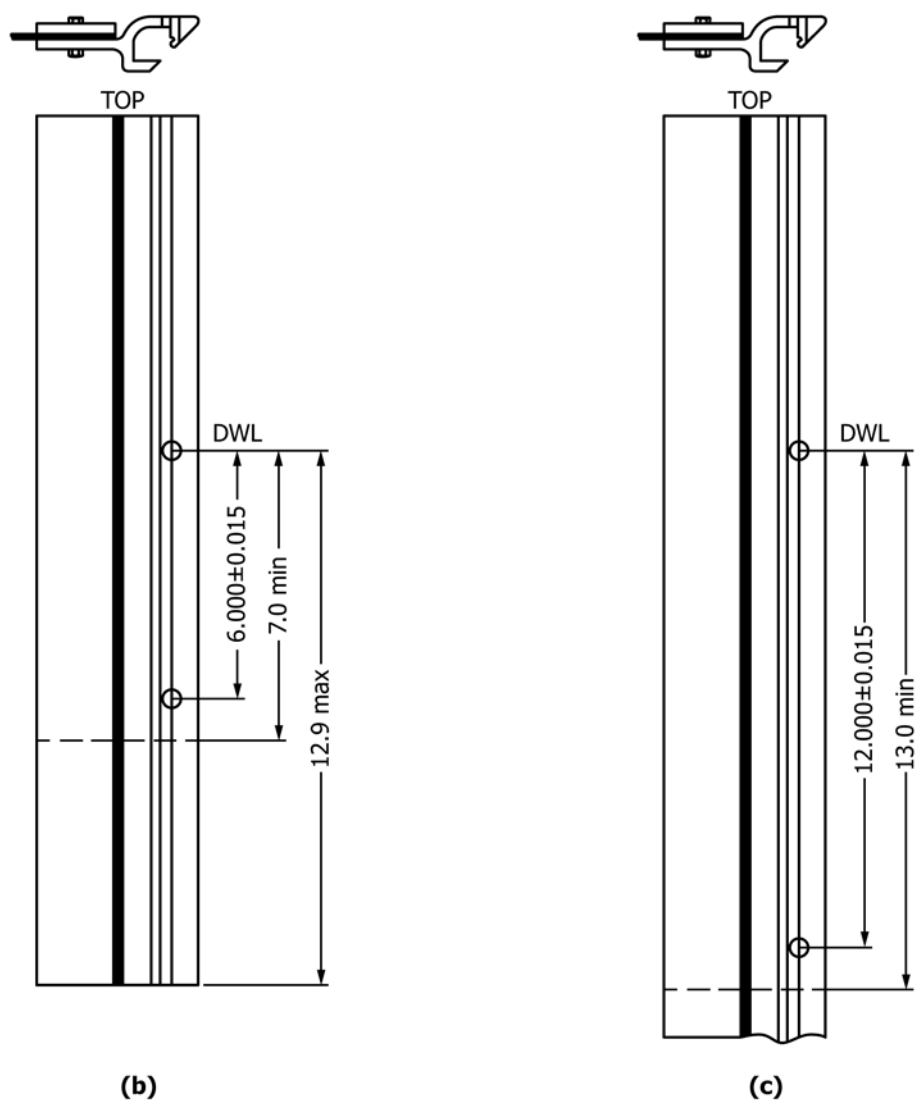
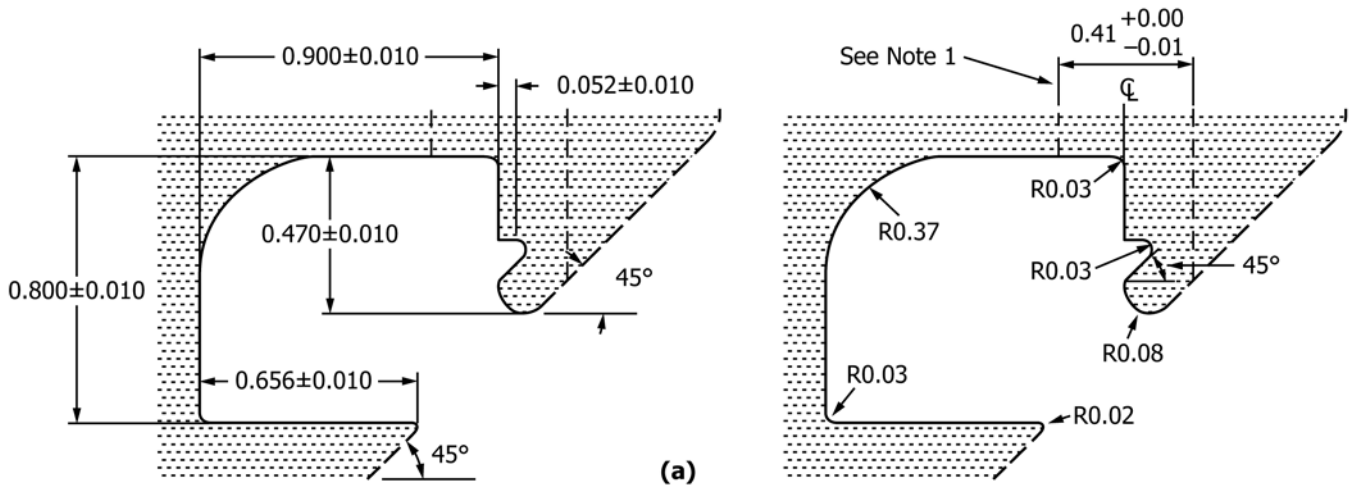



FIG. 3 Self-Locking Pin, Lanyard Assembly, and Lanyard Tensile Test



NOTE 1—0.41-in. diameter (+0.00-0.01) drill through for self-locking pinhole(s).
 NOTE 2—Surface of connector is to be defined by manufacturer where shown in dashed lines on this drawing, provided that no part of the surface protrude beyond these dashed lines.
 NOTE 3—All dimensions are stated in inches.
 NOTE 4—All top and bottom corners of each connector shall have a minimum 0.06 in. radius to reduce the possibility of injury to boom handlers.

FIG. 4 Slide Connector Configuration
4

 **F2438 – 04 (2017)**

ASTM International takes no position respecting the validity of any patent rights asserted in connection with any item mentioned in this standard. Users of this standard are expressly advised that determination of the validity of any such patent rights, and the risk of infringement of such rights, are entirely their own responsibility.

This standard is subject to revision at any time by the responsible technical committee and must be reviewed every five years and if not revised, either reapproved or withdrawn. Your comments are invited either for revision of this standard or for additional standards and should be addressed to ASTM International Headquarters. Your comments will receive careful consideration at a meeting of the responsible technical committee, which you may attend. If you feel that your comments have not received a fair hearing you should make your views known to the ASTM Committee on Standards, at the address shown below.

This standard is copyrighted by ASTM International, 100 Barr Harbor Drive, PO Box C700, West Conshohocken, PA 19428-2959, United States. Individual reprints (single or multiple copies) of this standard may be obtained by contacting ASTM at the above address or at 610-832-9585 (phone), 610-832-9555 (fax), or service@astm.org (e-mail); or through the ASTM website (www.astm.org). Permission rights to photocopy the standard may also be secured from the Copyright Clearance Center, 222 Rosewood Drive, Danvers, MA 01923, Tel: (978) 646-2600; <http://www.copyright.com/>