



Standard Test Method for Burst Strength of Surgical Sealants¹

This standard is issued under the fixed designation F2392; the number immediately following the designation indicates the year of original adoption or, in the case of revision, the year of last revision. A number in parentheses indicates the year of last reapproval. A superscript epsilon (ϵ) indicates an editorial change since the last revision or reapproval.

1. Scope

1.1 This test method provides a means for comparison of the burst or rupture strength of sealants on soft tissue. This test method can be used as a clinically relevant model for quality assurance, development, and comparative testing of different adhesives or adherends.

1.2 This test method measures only burst strength or “cohesive strength” of an adhesive/adherend system, and not the adhesive strength.

1.3 The values stated in SI units are to be regarded as standard. No other units of measurement are included in this standard.

1.4 *This standard does not purport to address all of the safety concerns, if any, associated with its use. It is the responsibility of the user of this standard to establish appropriate safety and health practices and determine the applicability of regulatory limitations prior to use.*

2. Referenced Documents

2.1 *ASTM Standards:*²
D907 Terminology of Adhesives

2.2 *American Association for Tissue Banks (AATB) Standard:*
Standards for Tissue Banking³

3. Terminology

3.1 *Definitions*—Many terms in this test method are defined in Terminology **D907**.

3.2 *Definitions:*

3.2.1 *adhesive failure*—failure of the sealant/substrate interface during burst testing.

3.2.2 *burst strength*—the average pressure required to cause failure of the sealant, either by cohesive or adhesive mechanisms.

3.2.3 *cohesive failure*—failure of the sealant during burst testing.

3.2.4 *cohesive strength*—the internal strength of the sealant, sometimes referred to as the adhesive bulk strength.

3.2.5 *substrate failure*—failure of the substrate during burst testing.

3.2.6 *tissue sealant*—a surface coating to prevent leakage of body fluids.

4. Significance and Use

4.1 Materials and devices that function at least in part by adhering to living tissues are finding increasing use in surgical procedures, either as adjuncts to sutures and staples or as frank replacements for those devices in a wide variety of medical procedures. While the nature and magnitude of the forces involved varies greatly with indication and with patient specific circumstances, all uses involve, to some extent, the ability of the material to resist imposed mechanical forces. Therefore, the mechanical properties of the materials, and in particular the adhesive and cohesive properties, are important parameters in evaluating their fitness for use. In addition, the mechanical properties of a given sealant composition can provide a useful means of determining product consistency for quality control, or as a means for determining the effects of various surface treatments on the substrate prior to use of the device.

4.2 The complexity and variety of individual applications for sealant, even within a single indicated use (surgical procedure), is such that the results of a burst test are not suitable for determining allowable design stresses without thorough analysis and understanding of the application and sealant behaviors.

4.3 This test method may be used for comparing sealants for susceptibility to environmental changes, but such comparisons must be made with great caution since different sealants may respond differently to varying conditions.

4.4 As the true sealant strength is strongly dependent on the strength of the sealant/substrate interface, the selection of a proper test substrate is critical. Care must be taken when extrapolating *in vitro* test results to *in vivo* expectations. *In*

¹ This test method is under the jurisdiction of ASTM Committee F04 on Medical and Surgical Materials and Devices and is the direct responsibility of Subcommittee F04.15 on Material Test Methods.

Current edition approved May 1, 2015. Published July 2015. Originally approved in 2004. Last previous edition approved in 2010 as F2392 – 04 (2010). DOI: 10.1520/F2392-04R15.

² For referenced ASTM standards, visit the ASTM website, www.astm.org, or contact ASTM Customer Service at service@astm.org. For *Annual Book of ASTM Standards* volume information, refer to the standard's Document Summary page on the ASTM website.

³ Available from American Association for Tissue Banks (AATB), 1320 Old Chain Bridge Rd., Suite 450, McLean, VA 22101.

vitro sealant optimization may not translate to expected *in vivo* performance due to differences in substrate surface, strength, and elasticity.

5. Apparatus

5.1 *Testing Machine*—A testing machine for determining the sealant strength and system failure mechanism and comprising essentially the following:

5.1.1 *Test Fixture*—A stationary fixture containing the test substrate and applied sealant. Fluid flows into the fixture at a fixed rate, allowing for the pressurization of the sealed substrate.

5.1.2 *Positive Displacement Fluid Pump*—A pump providing a constant flow of fluid to the test fixture. The pump must be capable of constant flow at pressures of interest. Syringe pumps are particularly well suited for this type of testing since they do not cause pulsatile flow. Peristaltic pumps have also been used successfully since the pump tubing tends to dampen pulsations.

NOTE 1—Saline is the typical fluid of choice. When air is used, a reduction in pressurization rate is expected due to gas compressibility.

5.1.3 *Pressure gage*—Consisting of a gage and method of capturing peak pressures. System sampling rate should be adequate to capture peak burst pressures. Sensitivity and precision should result in less than 1 % error. The burst test system is shown in Fig. 1. The system (A) consists of a fluid pump, a test fixture, and pressure gage connected by rigid plastic tubing. The test fixture (B) consists of a base, O-ring, and top.

5.2 *Temperature-controlling Equipment*—Must be capable of maintaining the test temperature to $\pm 2^\circ\text{C}$. If ambient laboratory conditions are employed, the same degree of control is required. A water bath or environmental chamber capable of maintaining 37°C is required for testing on tissue substrates.

6. Test Substrate

6.1 *For Comparative Testing*—Collagen sausage casing, Nippi Casing Co. (#320), should be used. It is a collagen casing of consistent properties and thickness.

NOTE 2—Nippi sausage casing (#320) is widely available throughout the meat packing industry.

6.2 Cut sections off of the collagen casing roll, wash in deionized water (to remove glycerin), then soak in fresh deionized water for five minutes.

6.3 *Application Specific Testing*—Since the fixture must clamp down on the substrate to prevent fluid leakage, some tissues (lung, liver, and so forth) may not be suitable for this test.

6.3.1 The burst strength of any sealant is dependant on its internal cohesive strength, as well as the adhesive strength to the test substrate, or adherend. For a specific application, the preferred substrate is freshly harvested tissue from the target organ of a domestic food animal. Tissue from bovine, porcine, or ovine origin is preferred due to wide availability and the fact

that relatively large samples of tissue can be harvested from a single source. Ideally, the tissue should be used within 24 h of harvest and should be kept between 5 and 10°C prior to testing if it cannot be used immediately after harvesting. Storage and handling of tissue samples should be carried out according to the guidelines set forth in Standards for Tissue Banking by the American Association of Tissue Banks. The specimens should be brought to the test temperature or other prescribed temperature (such as body temperature) prior to application of the sealant.

6.3.2 Fixed tissue should not be used since it has been demonstrated that fixatives cause large alterations in the mechanical properties of the tissue and it is probable that the adhesive strength would be affected as well.

6.3.3 If the target organ is of a size or geometry, or both, that does not allow fabrication of test samples, a tissue of similar origin but larger size should be used.

6.3.4 The thickness of the tissue sample should be minimized and should not exceed 5 mm. Thicker samples will lead to distortion of the substrate and may leak in the test fixture. Also, thicker samples will lead to sealant adherence on the insides of the hole itself, possibly leading to different failure mechanisms. It is also important that the thickness be as uniform as possible.

6.4 Substrates for Quality Control Testing:

6.4.1 For testing that is undertaken as part of a quality control process in the manufacturing of a tissue sealant, the use of freshly harvested tissue is highly inconvenient and may also lead to unacceptable variation in the test results, especially if the failure occurs in the adherend (substrate failure). Since the purpose of quality control testing is to demonstrate consistency in the device, substitution of a model substrate is preferred so long as it is demonstrated that the sealant does bond to the adherend. Since the burst test failure mechanism can depend on the amount of substrate deformation, attention to substrate flexibility and elasticity is important to best match *in vivo* substrates.

7. Substrate Preparation

7.1 Cut substrate into circles (3.0 ± 0.1 cm diameter) using a sharp scalpel or stamp.

7.2 Use a hole punch to create a 3.0 mm diameter hole in the center of the circular substrate.

NOTE 3—Depending on the application, different hole sizes, cuts, or suture lines may be used. Store in saline at room temperature until ready to use if testing will be done within 1 h of preparation. Prepared substrate may be stored in saline in a refrigerator for up to 48 h.

7.3 *Number of Test Specimens*—Test at least 10 specimens of each type. Burst testing tends to give high variances and will require more samples to attain a reasonable estimate of the mean strength. The actual number of test samples tested will depend on data variance.

8. Sample Preparation

8.1 Tissue Preparation:

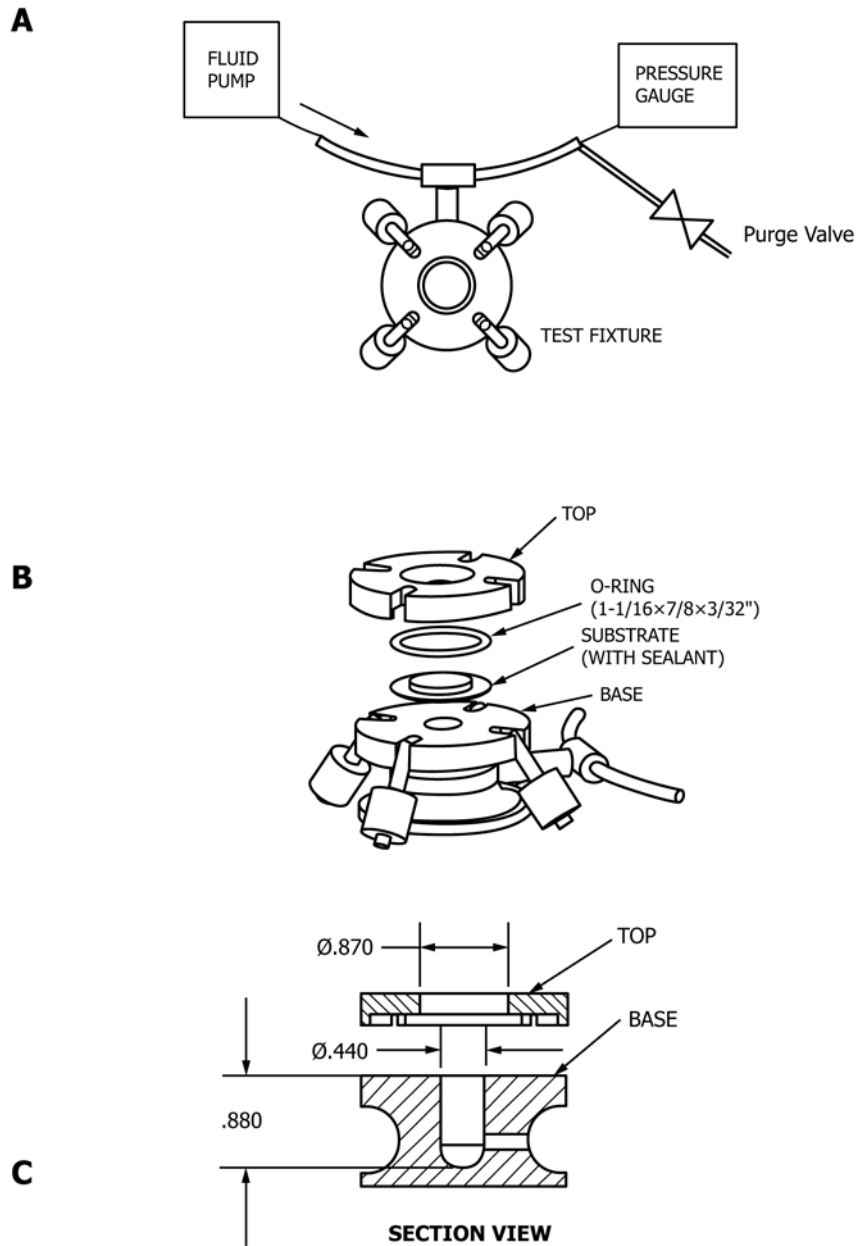

FIG. 1 Burst Test System (A), with an Exploded View of the Assembled Test Fixture (B), and the Test Fixture Cross Sectional View (in.) (C)

8.1.1 Place substrate on a polytetrafluoroethylene (PTFE) sheet and smooth out.

8.1.2 Pat substrate using surgical gauze to remove excess water.

8.1.3 Place an approximately 1.0 mm thick PTFE mask on top of the substrate, centering the 15 mm hole in the mask over the hole in the substrate as shown in Fig. 2.

8.2 Sealant Application:

8.2.1 Assemble the applicator and prepare the tissue sealant as directed for the product being tested. Use appropriate tip.

8.2.2 Apply the sealant per the instructions for use (IFU) in quantities sufficient to fill the hole in the PTFE mask. Record the volume of adhesive used.

NOTE 4—Thickness is a very important parameter to control. Variable thickness will lead to greater burst strength variation.

NOTE 5—Low viscosity sealants may flow through the 3 mm hole and under the substrate during this procedure. This may be prevented by placing a thin layer of petroleum jelly between the PTFE and substrate.

8.2.3 Allow the adhesive to cure per the IFU.

8.2.4 Lightly run an aluminum spatula around the edges of the sample to release from the mold.

8.2.5 Peel the substrate off the PTFE block, being careful not to tear the tissue sealant.

8.2.6 Samples tested more than 5 min after sealant application should be covered with gauze soaked in saline and stored at the conditioning temperature (see 9.1).

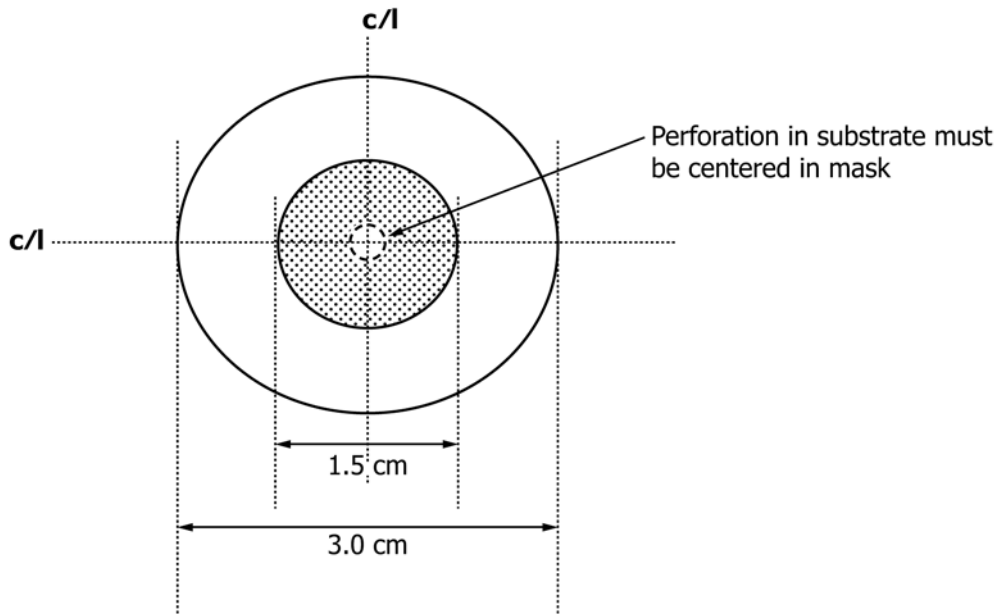

Thickness = 1 ± 0.5 mm

FIG. 2 PTFE Mask for Adhesive Application

9. Test Procedure

9.1 Condition the test specimens for definite periods of time under specified, controlled conditions before testing if desired. Recommended conditions for tissue sealants intended for internal applications are $37 \pm 1^\circ\text{C}$ in phosphate buffered saline. For quality control testing the recommended conditions are $23 \pm 2^\circ\text{C}$ and $50 \pm 5\%$ relative humidity.

9.2 After conditioning, it is recommended that all specimens be stabilized at the test temperature for 15 min before testing if the test temperature is different from the conditioning temperature. Tissue samples must be kept moist throughout the process to prevent shrinkage due to drying. For comparative testing the test conditions should be $23 \pm 2^\circ\text{C}$ and $50 \pm 5\%$ relative humidity (see [Appendix X1](#)).

9.3 Test Fixture Assembly:

9.3.1 Open the purge valve and turn on the fluid pump, thus priming the test fixture with saline to eliminate air from the fluid line.

9.3.2 Turn off the pump, and then place the substrate with tissue sealant onto the fixture base, with the sealant facing up. Place the O-ring (22 mm ID) on top of the tissue, and secure the fixture top in place.

9.4 Zero the pressure gage, and set to capture the peak pressure.

9.5 Advance saline into the test fixture by turning the fluid pump on at a flow rate of 2 mL/min. Close the purge valve after flow is established and all air has been purged from the lines.

9.6 Record the peak pressure, and the type of failure (cohesive, adhesive, or substrate) based on observation of the burst test.

10. Calculation

10.1 Calculate the average and standard deviation of burst strength for each group of samples.

11. Report

11.1 Report the following:

11.1.1 Complete identification of the sealant tested, including type, source, date manufactured, manufacturer's code number, and lot number.

11.1.2 Complete identification of the substrate used, its thickness, and any method used to clean or prepare the surface prior to bonding.

11.1.3 Estimated amount of sealant applied.

11.1.4 Method of sealant application.

11.1.5 Ambient conditions at time of bonding (temperature, humidity, and so forth).

11.1.6 Average thickness of the sealant.

11.1.7 Conditioning of specimen after application and prior to testing.

11.1.8 Maximum, minimum, mean, and standard deviation of the burst strength for the group of specimens.

11.1.9 Number of specimens tested.

11.1.10 Type of failure.

11.1.11 Test temperature and humidity employed.

12. Precision and Bias

12.1 A precision and bias statement does not exist for this test method because round-robin testing has not yet been performed.

13. Keywords

13.1 adhesive strength; burst strength; cohesive strength; tissue sealant

APPENDIX

(Nonmandatory Information)

X1. RATIONALE

X1.1 As with all mechanical testing, the temperature and humidity can have a large effect on the results obtained using this procedure. Ideally, all of the testing will be carried out at the intended use temperature (37°C for internal applications), and at a constant relative humidity. However, the equipment required for environmental control is not available in all

laboratories. Furthermore, attempting to test samples immediately after removal from the conditioning bath would lead to unacceptable variation in sample temperature at the time of failure. Therefore it was decided to allow the samples to cool to room temperature for 15 to 20 min prior to testing to eliminate that source of variability.

ASTM International takes no position respecting the validity of any patent rights asserted in connection with any item mentioned in this standard. Users of this standard are expressly advised that determination of the validity of any such patent rights, and the risk of infringement of such rights, are entirely their own responsibility.

This standard is subject to revision at any time by the responsible technical committee and must be reviewed every five years and if not revised, either reapproved or withdrawn. Your comments are invited either for revision of this standard or for additional standards and should be addressed to ASTM International Headquarters. Your comments will receive careful consideration at a meeting of the responsible technical committee, which you may attend. If you feel that your comments have not received a fair hearing you should make your views known to the ASTM Committee on Standards, at the address shown below.

This standard is copyrighted by ASTM International, 100 Barr Harbor Drive, PO Box C700, West Conshohocken, PA 19428-2959, United States. Individual reprints (single or multiple copies) of this standard may be obtained by contacting ASTM at the above address or at 610-832-9585 (phone), 610-832-9555 (fax), or service@astm.org (e-mail); or through the ASTM website (www.astm.org). Permission rights to photocopy the standard may also be secured from the Copyright Clearance Center, 222 Rosewood Drive, Danvers, MA 01923, Tel: (978) 646-2600; <http://www.copyright.com/>