



# Standard Specification for Temperature Monitoring Equipment<sup>1</sup>

This standard is issued under the fixed designation F2362; the number immediately following the designation indicates the year of original adoption or, in the case of revision, the year of last revision. A number in parentheses indicates the year of last reapproval. A superscript epsilon ( $\epsilon$ ) indicates an editorial change since the last revision or reapproval.

*This standard has been approved for use by agencies of the U.S. Department of Defense.*

## 1. Scope

1.1 This specification covers the requirements for equipment intended to provide control input and monitoring of temperatures in general applications. Equipment described in this specification includes temperature indicators, signal conditioners and power supplies, and temperature sensors such as thermocouples and resistance temperature element assemblies.

1.2 Special requirements for Naval shipboard applications are included in the Supplementary Requirements section.

1.3 The values stated in SI units are to be regarded as the standard. The values given in parentheses are for information only.

## 2. Referenced Documents

2.1 *ASTM Standards:*<sup>2</sup>

D3951 Practice for Commercial Packaging

E344 Terminology Relating to Thermometry and Hydrometry

## 3. Terminology

3.1 *Definitions*—Definitions of terminology shall be in accordance with Terminology E344.

## 4. Classification

4.1 *General*—Temperature measuring devices are generally classified as either temperature sensors or thermometers. Thermometers are not covered by this specification. Temperature sensors are classified by design and construction. Sensors may also be classified by the manner of response, basically mechanical or electrical, to a change in temperature. Mechanical response is characterized by some mechanical action as temperature changes. Electrical response is characterized by the

production or change of an electrical signal or property as temperature changes. The following describes the most common types of sensors:

4.2 *Thermocouples*—Thermocouples are constructed in a variety of designs to provide measurement of direct or differential temperature. Thermocouples are commonly installed using a thermowell which protects the thermocouple but also delays the rapid response time characteristic of thermocouples.

4.2.1 *Principle of Operation*—Most thermocouples utilize two wires fabricated from dissimilar metals joined at one end to form a measuring junction that is exposed to the process medium being measured. The other ends of the wires are usually terminated at a measuring instrument which forms a reference junction. When the two junctions are exposed to different temperatures, electrical current will flow through the circuit (Seebeck Effect). The measurement of millivoltage resulting from the current is proportional to the temperature being sensed.

4.2.2 *Types of Thermocouples*—Thermocouples can be divided into functional classes by materials and therefore, temperature ranges. The three classes are base metal, noble metal, and refractory metal. Although many types are commonly used in industrial applications, the Instrument Society of America (ISA) has assigned letter designations to seven types. By convention, the practice of using a slash mark to separate the materials of each thermocouple wire is widely accepted. Likewise, the order in which the materials appear also denotes polarity of the wires; positive/negative when the measuring junction is at a higher temperature than the reference junction. The following are examples of typical thermocouples:

Class	Type	Materials	Temperature (max)
Base metal	J	Iron/constantan	1000°C (1832°F)
Base metal	T	Copper/constantan	1000°C (1832°F)
Base metal	K	Chromel/Alumel	1000°C (1832°F)
Base metal	E	Chromel/constantan	1000°C (1832°F)
Base metal	---	Alloys of copper, nickel, iron, chromium, manganese, aluminum, and other metals	1000°C (1832°F)
Noble metal	---	Various noble metals	2000°C (3632°F)
Refractory metal	---	Tungsten-rhenium, tantalum, molybdenum, and their alloys	2600°C (4712°F)

<sup>1</sup> This specification is under the jurisdiction of ASTM Committee F25 on Ships and Marine Technology and is the direct responsibility of Subcommittee F25.10 on Electrical.

Current edition approved Oct. 1, 2013. Published October 2013. Originally approved in 2003. Last previous edition approved in 2009 as F2362 - 03 (2009). DOI: 10.1520/F2362-03R13.

<sup>2</sup> For referenced ASTM standards, visit the ASTM website, www.astm.org, or contact ASTM Customer Service at service@astm.org. For *Annual Book of ASTM Standards* volume information, refer to the standard's Document Summary page on the ASTM website.

4.3 *Resistance Temperature Measuring Devices*—Resistance thermometers measure changes in temperature based on changes in resistance of the sensor element exposed to the temperature. Two common types are resistance temperature detectors which have metal sensor elements and thermistors which have semiconductor sensor elements.

4.3.1 *Resistance Temperature Detectors (RTDs)*—An RTD consists of sensor which uses a metal wire or fiber which responds to changes in temperature by changing its resistance. The sensor is connected to a readout via a bridge circuit or other means of translating the resistance to a temperature value.

4.3.1.1 *Types of RTDs*—RTD designs include averaging RTDs, annular RTDs, and combination RTD-thermocouples. Averaging RTDs are characterized by a long resistance element. Annular RTDs have sensors that are designed to provide a tight fit within the inner walls of thermowells. Combination RTD-thermocouples have both an RTD and a thermocouple housed in the same sheath.

4.3.2 *Thermistors*—Thermistors are made of solid semiconductor materials, usually complex metal oxides, that have a high coefficient of resistance. Thermistors are available with positive and negative temperature coefficients of resistance and are usually designated PTC and NTC thermistors, respectively. The temperature range for typical thermistors is 100 to 300°C (212 to 572°F).

4.3.2.1 *Types of Thermistors*—Thermistors are classed by the configuration of the semiconductor material. Common types are the bead, disc, washer, and rod thermistors. Leads are attached to semiconductor materials, except where metal plated faces are used for contact to complete the circuit.

## 5. Ordering Information

5.1 The purchaser should provide the manufacturer with all of the pertinent application data outlined in the acquisition requirements.

5.2 *Acquisition Requirements*—Acquisition documents should specify the following:

- 5.2.1 Title, number and date of this specification,
- 5.2.2 Classification required,
- 5.2.3 Quantity of units required,
- 5.2.4 Type of enclosure mounting,
- 5.2.5 Power requirements,
- 5.2.6 Equipment temperature ranges,
- 5.2.7 Size or weight limitations,
- 5.2.8 Disposition of qualification test samples,
- 5.2.9 Product marking requirements, and
- 5.2.10 Special preservation, packaging, packing and marking requirements.

## 6. Materials and Manufacture

6.1 *Temperature Sensors*—The materials for all wetted parts shall be selected for long term compatibility with the process medium.

## 7. Physical Properties

7.1 *Description*—The equipment specified herein in conjunction with the thermocouples or resistance temperature

measuring elements comprise a temperature instrument. The temperature monitoring equipment may consist of the following units and may be built integrally together and housed in the same enclosure:

7.1.1 *Signal Conditioner*—The signal conditioner shall convert the sensing element output to a continuous linear analog signal directly proportional to temperature.

7.1.2 *Power Supply*—The power supply shall provide excitation energy to the signal conditioner and sensor.

7.1.3 *Test Device*—A test device shall be furnished to provide a calibrated test signal used for calibrating the equipment.

7.2 *Size and Weight Considerations*—A dimensional outline of the temperature monitoring equipment showing overall and principle dimensions in sufficient detail to establish space requirements in all directions necessary for installation and servicing will greatly assist proper selection. In many applications weight is a critical limitation.

7.3 *General Features*—Requirements for general features shall be specified. General features consist of the following:

- 7.3.1 Output,
- 7.3.2 Equipment range,
- 7.3.3 Adjustments,
- 7.3.4 Failsafe output,
- 7.3.5 Isolation,
- 7.3.6 Enclosure,
- 7.3.7 Power supply requirements, and
- 7.3.8 Cable entrance and connection.

## 8. Performance Requirements

8.1 *Service Life*—The purchaser may have a minimum specified service life requirement. Critical service life requirements shall be specified in the acquisition requirements.

8.2 *Performance Considerations*—Certain performance characteristics may be deemed critical to the intended or desired function of temperature monitoring equipment. Performance tolerances are usually expressed in percent of equipment span. The following performance characteristics and environmental exposures should be tailored to each purchaser's intended application:

- 8.2.1 Accuracy,
- 8.2.2 Repeatability,
- 8.2.3 Threshold and deadband,
- 8.2.4 Ripple,
- 8.2.5 Warm-up time,
- 8.2.6 Input resistance,
- 8.2.7 Supply voltage or frequency, or both,
- 8.2.8 Temperature error,
- 8.2.9 Response time,
- 8.2.10 Temperature,
- 8.2.11 Insulation resistance,
- 8.2.12 Vibration, and
- 8.2.13 Shock.

## 9. Workmanship, Finish, and Appearance

9.1 *Finish and Appearance*—Any special surface finish and appearance requirements shall be specified in the acquisition requirements.

## 10. Number of Tests and Retests

10.1 *Test Specimen*—The number of test specimens to be subjected to qualification testing shall depend on the sensor design. If each range is covered by a separate and distinct design, a test specimen for each range may require testing. In instances where a singular design series may cover multiple ranges and types, only three test specimens may need to be tested provided the electrical and mechanical similarities are approved by the purchaser. In no case, however, should less than three units, one unit each representing low, medium, and high ranges, be tested, regardless of design similarity.

## 11. Test Data

11.1 *Test Data*—All test data shall remain on file at the manufacturer's facility for review by the purchaser upon request. It is recommended that test data be retained in the manufacturer's files for at least three years, or a period of time acceptable to the purchaser and manufacturer.

## 12. Inspection

12.1 *Classification of Inspections*—The inspection requirements specified herein are classified as follows:

- 12.1.1 Qualification testing, and
- 12.1.2 Quality conformance testing.

12.2 *Qualification Testing*—Qualification test requirements shall be specified where applicable. Qualification test methods should be identified for each design and performance characteristic specified. Test report documentation requirements should also be specified.

12.3 *Quality Conformance Testing*—Quality conformance testing is accomplished when qualification testing was satisfied by a previous acquisition or product has demonstrated reliability in similar applications. Quality conformance testing is

usually less intensive than qualification, often verifying that samples of a production lot meet a few critical performance requirements.

## 13. Certification

13.1 When specified in the purchase order or contract, the purchaser shall be furnished certification that samples representing each lot have been either tested or inspected as directed in this specification and the requirements have been met. When specified in the purchase order or contract, a report of the test results shall be furnished.

## 14. Product Marking

14.1 Purchaser specified product marking shall be listed in the acquisition requirements.

## 15. Packaging and Package Marking

15.1 *Packaging of Product for Delivery*—Product should be packaged for shipment in accordance with Practice **D3951**.

15.2 Any special preservation, packaging, or package marking requirements for shipment or storage shall be identified in the acquisition requirements.

## 16. Quality Assurance Provisions

16.1 *Warranty*:

16.1.1 *Responsibility for Warranty*—Unless otherwise specified, the manufacturer is responsible for the following:

- 16.1.1.1 All materials used to produce a unit, and
- 16.1.1.2 Manufacturer will warrant his product to be free from defect of workmanship to produce the unit.

## 17. Keywords

17.1 resistance temperature detector (RTD); thermistor; thermocouple

## SUPPLEMENTARY REQUIREMENTS

### TEMPERATURE MONITORING EQUIPMENT (NAVAL SHIPBOARD USE)

The following supplementary requirements established for U.S. Naval shipboard application shall apply when specified in the contract or purchase order. When there is conflict between the standard (ASTM F2362) and this supplement, the requirements of this supplement shall take precedence for equipment acquired by this supplement. This document supercedes MIL-T-15377, Temperature Monitor Equipment, Naval Shipboard, for new ship construction.

## S1. Scope

S1.1 This supplement covers temperature monitoring equipment which continuously monitors and selectively indicates, at a central location, a number of temperatures at remote equipment locations on board naval ships.

S1.2 *Monitoring Equipment*—Monitoring equipment, in conjunction with the temperature sensor assemblies and interconnecting cabling, comprise a temperature measuring and alarm system. In order to warn operating personnel of abnor-

mal temperature conditions, the system shall energize an audible and visual alarm when the temperature at a particular location is below or above a preset limit. Monitoring of temperatures shall be accomplished by measuring the electromotive force (emf) output of thermocouples or by measuring the signal output due to changes in resistance of temperature sensing elements. Temperature monitoring equipment shall actuate external audible alarms specified herein.

**S1.3 Selective Temperature Readout Equipment**—Selective temperature readout equipment, in conjunction with temperature sensor assemblies and interconnecting cabling, comprise a temperature measuring system. In order to enable operating personnel to measure a number of temperatures at remote points, the system shall enable the operator to manually select the desired point to be measured, convert the selected temperature sensor output to a signal proportional to temperature, and display this signal on a meter calibrated in temperature °C (°F). Readout of temperatures shall be accomplished by measuring the output of thermocouples or by measuring the signal output due to changes in resistance of temperature sensing elements.

**S1.4** The U.S. Government preferred system of measurement is the metric SI system. However, since this item was originally designed using inch-pound units of measurement, in the event of conflict between the metric and inch-pound units, the inch-pound units shall take precedence.

## S2. Referenced Documents

### S2.1 Commercial Documents:

ANSI C96.1 Temperature Measurement Thermocouples<sup>3</sup>

### S2.2 Government Documents:<sup>4</sup>

#### S2.2.1 Military Standards:

MIL-STD-167-1 Mechanical Vibrations of Shipboard Equipment (Type I—Environmental and Type II—Internally Excited)

MIL-STD-1399 Interface Standard for Shipboard Systems Electric Section 300 Power, Alternating Current (Metric)

#### S2.2.2 Military Specifications:

MIL-S-901 Shock Tests, H.I. (High-Impact); Shipboard Machinery, Equipment and Systems, Requirements for

MIL-PRF-19207/1 Fuseholders, Extractor Post Type, Blown Fuse Indicating, Type FHL10U

MIL-PRF-19207/2 Fuseholders, Extractor Post Type, Blown Fuse Indicating, Type FHL11U

## S3. Terminology

### S3.1 Definitions:

**S3.1.1 temperature monitoring equipment**—the necessary equipment required to continuously or selectively sense and indicate various temperatures including audible and visual alarms when specified.

## S4. Classification

**S4.1 Classification**—Monitoring and selective temperature readout equipment classification shall be of following format:

Example: ASTM F2362S1-IC/A-1-RTE-40

Specification	Type	Alarm	Sensing Technique	Number of Channels
F2362S1	IC/A (see S4.2)	1 (see S4.3)	RTE (see S4.4)	40 (see S4.5)

**S4.2 Type**—The equipment shall be designated by the 3 letter symbols as follows:

IC/A—Continuous, simultaneous monitoring of remote temperature sensors for alarm and also manual selective temperature readout.

IC/I—Manual selective temperature readout for measuring temperatures at several remote locations.

IC/S—Continuous, sequential scanning of remote temperature sensors for indication and alarm.

**S4.3 Alarm**—The alarm technique shall be designated by a single number as follows:

1—Alarm on temperature above the set level or (exclusive or) below the set level as operator selected.

2—No alarm provision—temperature readout only.

**S4.4 Temperature Sensing Technique**—The temperature sensing technique shall be designated by 3 letter symbols as follows:

RTE—Resistance temperature element, platinum.

TCE—Thermocouple temperature element, type K.

**S4.4.1 Readout Ranges**—Readout ranges shall be provided as specified as follows:

(1) For RTE type sensors, the following ranges and meter scales shall be provided:

(a) 5 to 127°C (-40 to 260°F)

(b) 18 to 205°C (0 to 400°F)

(c) 18 to 427°C (0 to 800°F)

(d) 18 to 538°C (0 to 1000°F)

(2) For type TCE sensors, the following ranges and meter scales shall be provided:

(a) 5 to 127°C (-40 to 260°F)

(b) 18 to 205°C (0 to 400°F)

(c) 18 to 427°C (0 to 800°F)

(d) 205 to 816°C (400 to 1500°F)

(e) 260 to 1093°C (500 to 2000°F)

**S4.5 Number of Channels**—The number of channels, corresponding to the number of remote sensors that monitored shall be designated by its numerical value.

## S5. Ordering Information

**S5.1** The purchaser shall provide the manufacturer with all of the pertinent application data shown in accordance with S5.2. If special application operating conditions exist that are not shown in the acquisition requirements, they shall also be described.

**S5.2 Acquisition Requirements**—Acquisition documents should specify the following:

(1) Title, number and date of this specification,

(2) Classification required,

(3) Quantity of items required,

(4) Number of temperature sensors to be monitored,

(5) Setting of alarm channels, if other than 93.3°C (200°F),

(6) Height and weight of equipment assembly,

(7) Number of remote resistance temperature sensors or remote thermocouple temperature sensors monitored by equipment,

(8) Equipment alarm and readout temperature range,

(9) Accuracy or other performance requirements,

(10) Disposition of qualification test samples, and

(11) Unique preservation, packaging and marking requirements.

<sup>3</sup> Available from American National Standards Institute (ANSI), 25 W. 43rd St., 4th Floor, New York, NY 10036.

<sup>4</sup> Available from Standardization Documents Order Desk, DODSSP, Bldg. 4, Section D, 700 Robbins Ave., Philadelphia, PA 19111-5098.



## S6. Materials and Manufacture

S6.1 Unless otherwise specified, equipment shall be fabricated from corrosion resistant materials compatible with system piping materials and process medium.

## S7. Physical Properties

### S7.1 Enclosure Assembly:

S7.1.1 *Temperature Monitor Equipment*—Equipment enclosure assembly shall be of sheet metal, splash-proof construction, and shall be suitable for either panel or bulkhead mounting. Splash-proof construction shall be such that water or solid particles directed at the enclosed equipment or its mounting surface shall have no harmful effect on equipment operation.

S7.1.2 *Continuous Parallel Monitoring (IC/A)*—Enclosure assembly for IC/A monitor equipment shall contain one temperature readout module and the number of alarm modules required to provide the number of alarm channels specified, up to a maximum of 60. Modules shall be readily removable from the enclosure assembly by means of integral plug-in features operable from the front of the enclosure. Access to the interior or back of the enclosure assembly shall not be required to accomplish removal of any module.

S7.1.3 *Temperature Readout Module*—The temperature module shall be a temperature readout device and associated circuits. Necessary controls shall be located on the front panel of the module.

S7.1.4 *Alarm Module (IC/A and IC/I)*—Indicator lights and controls shall be located on the front panel of each alarm module to perform the following functions. Multi-position switches may be utilized to combine control functions specified.

- (1) Power on light (white lens).
- (2) Alarm light for each temperature monitoring channel (red lens).
- (3) External alarm cut-out (silence) switch for each temperature monitoring channel.
- (4) Alarm set potentiometer.
- (5) External alarm cut-out (silence) switch for temperature monitoring channels (one per equipment).
- (6) Alarm circuit reset switch: one per module (if required).
- (7) Test switch to verify continuity of alarm circuit, alarm light, and temperature sensor (one per module).
- (8) Read (indicate) light on each temperature monitoring channel to light when it has been selected at the readout module.

S7.1.5 *Access (IC/A)*—Electrical connection between alarm and readout modules and between modules and the other circuits within the enclosure assembly shall be by means of quick-disconnect connectors. Required auxiliary circuits, such as the power supply, shall be located within the enclosure assembly in such a location as to be readily accessible from the front of the enclosure assembly. Required controls and indicators, associated with the power supply, shall be on the front panel. Fold down or slide drawer chassis construction may be used. Terminals and terminal boards shall be provided for interconnection to ships power, temperature sensors, and external audible alarm. These terminals shall also be located to

be accessible from the front of the enclosure assembly. Three 2.44 m (8 ft) long cable assemblies shall be provided and stowed securely inside each equipment enclosure. With these cable assemblies, it shall be possible to remove any one alarm module and the power supply, readout, alarm, and calibration modules to operate the equipment in a normal manner on a work bench away from the installed console. These cable assemblies shall only be required to obtain access for special testing, trouble shooting, and repair.

S7.1.6 *Manual Selective Temperature Readout Equipment (IC/I)*—Enclosure assembly shall contain the temperature indicating meter, selector switch for selecting the desired temperature sensor to be read, all required, associated functional circuits and parts, and terminals for interconnection to external power and temperature sensors.

S7.1.7 *Continuous Scanning Monitoring (IC/S)*—Enclosure assembly for IC/S shall contain a readout, a micro processor, input multiplexers, A/D converters, and alarm circuits required to provide the number of channels specified, up to a maximum of 60. Operating controls and the readout shall be accessible from the front panel. A provision shall be included whereby the function of the front panel controls can be disabled to prevent tampering by unauthorized personnel.

S7.1.8 *Temperature Monitor Equipment (IC/A)*—One identification plate shall be provided for each enclosure assembly. Individual identification plates shall be provided on each module (alarm and indicator unit) showing the location of the associated temperature sensing element, next to each alarm light, and identifying the function of controls and indicators located on the front of each module. As an alternate, identification plates showing location of temperature sensor elements may be provided on the overall equipment frame adjacent to each module location. Plates shall also provide for indicating the proper scale to use on the readout for each channel if a dial type meter is used. Adjustment, calibration, setting, and standardization controls located within the enclosure assembly, shall also be identified by means of identification plates. Temperature sensor connection terminals shall be marked to correspond with the position identification for monitor point.

S7.1.9 *Selective Temperature Readout Equipment (IC/I)*—The position of all selector switches shall be marked to identify the temperature sensor selected to be measured. Adjustment, calibration, and sensor connection terminals located within the enclosure assembly shall be identified and marked.

S7.1.10 *Continuous Scanning Monitoring (IC/S)*—The equipment display shall identify the location of the temperature element when an alarm condition occurs.

### S7.2 System Requirements:

S7.2.1 *Temperature Monitor Equipment (IC/A)*—IC/A temperature monitor equipment shall provide for continuous paralleled monitoring of up to 60 temperature sensors. Equipment shall be modular, with individual modules having plug-in features as specified in S7.1.2. There shall be at least 3 types of modules:

- (1) Monitor and alarm,
- (2) Readout, and
- (3) Power supply module.

Each monitor and alarm module shall monitor 4 temperature sensors. Equipment shall be capable of operating, as specified herein, with each of the 60 temperature alarm set points adjusted for a different temperature setting. Any alarm may be activated regardless of the state of any other alarm. For purposes of standardization, the factory setting shall be approximately 93.3°C (200°F) for points, unless otherwise specified in the acquisition requirements.

**S7.2.2 Visual Alarm**—Each monitor point shall be uniquely associated with a specific remote temperature sensor and shall have its own individual indicating light. When the temperature at the point being monitored reaches a predetermined temperature setting (alarm point), the indicator light shall be energized and remain energized until manually reset.

**S7.2.3 Audible Alarm**—One relay or electronic switch having 5 A minimum rating DPDT operation shall be provided for supplying 115 V alternating current (ac) power for actuating an external audible alarm simultaneously with activating the visual alarm. The alarm relay switch shall be wired to the panel terminal boards in the cable entrance stuffing box. The audible alarm shall be activated when any one or more of the temperatures being monitored reaches the predetermined (alarm) setting. Each channel shall provide a manual switch for cutting out the audible alarm for its own monitoring point. This cut-out shall not prevent any of the other channels from sounding the audible alarm should the temperature at any other monitored point reach the predetermined (alarm) setting. A single, master cut-out switch with associated indicator light shall be provided, which will disable the sounding of the external audible alarm for the entire system.

**S7.2.4 Independent Action**—The monitoring and alarm action of individual points shall be independent of each other. Action of indicating an alarm condition at one or more monitor points shall not prevent the system (equipment) from indicating an alarm condition at other monitor points.

**S7.2.5 Temperature Readout**—The temperature readout device and channel selector switch shall be provided in a readout module. The selector switch shall be depressed to turn so that momentary contact is not made with intermediate channels. The continuous, automatic monitor and alarm capability of the system shall not be affected by the selection of a temperature sensor for reading. When a channel temperature reading is being taken, the alarm feature of all points including the one being measured shall be maintained. The operation of the readout module shall not depend on balancing motors, slidewires, potentiometers, or similar devices. The use of potentiometers shall be limited to test, adjustment, and calibration purposes only.

**S7.2.6 Test Feature**—A test switch shall be provided for each monitor and alarm module for testing alarm lights and continuity of each temperature sensor and alarm circuits of that module. When the switch is operated to the “test” position, the channel alarm light shall indicate an alarm condition. Failure of the channel alarm light on the module to light shall indicate an open circuit in the lamp, temperature sensor, or in the associated alarm circuit. This test operation shall not change the normal state of the alarm relays or external relays.

**S7.2.7 Fail Safe Design**—The IC/A temperature monitor equipment shall have an inherent “fail safe” feature. An open circuit in the external temperature sensor or its connecting cabling shall result in an alarm condition.

**S7.2.8 Calibration and Setting of Alarm Point**—Design of the IC/A temperature monitor equipment shall be such as to facilitate calibration and adjustment of the individual alarm set points. Self calibration capability shall be an inherent design feature. Test jacks shall be provided to facilitate direct connection to external instrumentation for test, calibration, and trouble shooting. Calibration, alarm set point adjustment and access to the test jacks shall not require disassembly or changes to the electrical wiring connections.

**S7.2.9 Cold Junction Compensation**—Cold junction compensation for equipment for thermocouple sensing shall be self-contained, automatic, and shall be referenced to 0°C (32°F).

**S7.2.10 Lead Length Compensation**—Equipment for resistance temperature sensing shall provide an input terminal for 3 wire sensor configuration. A means shall be provided to compensate for the resistance of interconnecting wiring between sensor and monitor equipment. This compensating provision and associated sensor input terminal configuration shall be arranged that it can be easily by-passed (removable jumper, alternate terminals, or similar means) for use with 2 wire resistance temperature elements. Equipment for thermocouple sensing shall provide for thermocouple lead length compensation. Accuracy, calibration, and response time shall be independent of thermocouple extension lead length.

**S7.2.11 Size and Weight**—Individual modules (alarm or readout) shall not exceed 15.24 cm (6 in.) in height, 7.62 cm (3 in.) in width, and 30.48 cm (12 in.) in depth. Total weight per module shall not exceed 5.44 kg (12 lb). The equipment assembly, containing the required number of alarm modules, the readout module, and power supply module shall not exceed 50.8 cm (20 in.) in width, and 35.6 cm (14 in.) in depth. The height and weight, determined by the number of temperatures the equipment is designed to monitor, shall be as specified in the acquisition requirements. The equipment assembly, containing the required number of alarm modules to monitor 60 temperatures, shall not exceed 129.6 cm (51 in.) in height. Total weight shall not exceed 90.7 kg (200 lb). For a 40 point monitor system, the equipment assembly shall not exceed 91.44 cm (36 in.) in height, and weight shall not exceed 68 kg (150 lb).

**S7.2.12 Selective Temperature Readout Equipment (IC/I)**—Equipment shall provide for the manual selection of any one of several remotely located temperature sensors and converting the signal output of the selected sensor to the signal required for display on a read-out device, calibrated in °C (°F). The operation of the readout equipment shall not depend on balancing motors, slide-wires, potentiometers, or similar devices. Use of potentiometers shall be limited to test, adjustment, and calibration purposes only. The equipment shall facilitate calibration without disassembly or changes to the electrical wiring connections. Test jacks shall be provided to permit direct connection to test and calibration instruments. An inherent “fail safe” feature shall be incorporated which will

result in an off-scale (high or low) reading to signal a failure in the manual selector, associated readout circuits, or an open or short in the external temperature sensor.

**S7.2.12.1 Size and Weight**—Selective temperature readout equipment assembly shall not exceed 30.48 cm (12 in.) in width, 30.48 cm (12 in.) in height, and 35.6 cm (14 in.) in depth. The total weight shall not exceed 18.14 kg (40 lb).

**S7.2.13 Continuous Scanning Monitoring, Indicating, and Alarm Equipment (IC/S)**—IC/S temperature monitor equipment shall provide for continuous scanning via micro processor of up to 60 temperature sensors. Equipment shall be modular, with individual modules having plug-in features. The equipment shall scan at a rate which will allow all channels to be scanned in 5 s or less. Alarm set points and temperature input characteristics shall be able to be re-programmed from the front panel. The equipment shall be capable of annunciating alarms regardless of number (up to 60) and regardless of previous alarm history.

**S7.2.14 Number of Readout Points (IC/A, IC/I and IC/S)**—The number of remote resistance temperature sensors or remote thermocouple temperature sensors monitored by the equipment shall be specified in the acquisition requirements.

**S7.3 Parts Requirements**—Electrical parts, mechanical parts, processes, and material shall be selected and applied to meet the requirements herein.

**S7.3.1 Batteries**—Batteries shall not be used.

**S7.3.2 Electrical Indicating Meters**—Electrical indicating meters shall be high-impact shock resistant, watertight, or hermetically sealed types, in accordance with one of the following:

- (1) 11.43 cm (4-1/2 in.) 250° nominal scale length.
- (2) Panel mounted, edgewise type.

**S7.3.3 Digital Readout**—Digital meters utilized in lieu of an electrical indicating meter (analog type readout) shall have a minimum of 4 digits. The meters shall be high-impact shock resistant, and watertight, or hermetically sealed.

**S7.3.4 Fuses**—Fuses shall be selected so that the overload blowing characteristics and short circuit interrupting capacity matches the overload protection requirements of the equipment and wiring being protected and the short circuit capacity of the supply circuit.

**S7.3.5 Fuse Mounting**—Fuses shall be mounted in panel mounted, indicating type fuse-holders. Fuse-holders FHL10 in accordance with MIL-PRF-19207/1 or FHL11 in accordance with MIL-PRF-19207/2 are preferred types.

**S7.3.6 Terminal Boards and Mounting**—Terminal boards shall be stud type and shall be secured only by bolts (machine screws) and shall be capable of ready removal and replacement. They shall be accessible from the front of the enclosure with the front cover plate removed or access door open.

**S7.3.7 Switches**—Switches shall be selected so that rated currents and voltages (make, break, carry) are not exceeded in the intended application, as well as for their ability to withstand the shipboard environments. Rotary switches are preferred for power circuit interruption. Readout channel selector switch shall be a “push to turn” type so that momentary contact is not made with intermediate channels while turning the switch.

## **S8. Performance Requirements**

**S8.1 Calibration and Accuracy**—Temperature monitoring equipment, selective temperature readout equipment, and continuous scanning temperature monitoring equipment shall comply with the calibration and accuracy requirements specified below. Equipment performance requirements specified herein are specified on the basis of simulating the signal output of the appropriate temperature sensors and applying this signal to the input terminals (temperature sensor terminal points) of the equipment.

**S8.1.1 Accuracy of Alarm Set Point**—Temperature monitoring equipment (IC/A, IC/I, and IC/S) shall permit the setting of the alarm point at any value over the designated temperature span. The error band of the alarm level setting shall be one-half the error band of the temperature readout on any full scale range.

**S8.1.2 Accuracy of Readout**—The readout error of the equipment shall not exceed  $\pm 2\%$  of the readout range for any readout range setting. The temperature indicated on the readout device shall be within  $\pm 2\%$  of the temperature equivalent to the simulated temperature sensor output in ohms or millivolts, as applicable.

**S8.2 Ambient Temperature Error**—The change in temperature reading (temperature error) of the equipment due to any changing ambient temperature from 4.5 to 65°C (40 to 149°F) shall not exceed 0.18 (0.1) % of full scale per °C (°F) change in ambient temperature.

**S8.3 Response Time:**

**S8.3.1 Alarm Circuits (IC/A and IC/I)**—The alarm shall be actuated within 0.1 s when a step signal change of 1.5 % of full scale is applied when the monitoring systems are reading 1.4 % of full scale below the alarm setting for any alarm setting from 5 to 100 % of full scale.

**S8.3.2 Alarm Circuits (IC/S)**—The alarm shall be actuated on the first scan cycle after the alarm condition appears at the input of the equipment. Alarms shall be programmable to actuate either above a set condition or below a set condition.

**S8.3.3 Temperature Readout**—Equipment shall display the steady state temperature reading  $\pm 2.0\%$  in less than 3 s when a step signal equivalent to 80 % (from 10 to 90 %) of full temperature span is applied to the temperature sensor input terminals of the temperature monitoring equipment console.

**S8.3.4 Compensation for RTE**—Equipment shall provide for 3 wire temperature sensor inputs. Means shall be provided to compensate for the resistance of interconnecting wiring between temperature sensor and the indicator equipment. Compensating provision and associated sensor input terminal configuration shall be so arranged that it can be easily bypassed (removable jumper, alternate terminals, or similar means) for use with 2 wire uncompensated resistance temperature sensors.

**S8.3.5 Compensation for TCE**—Cold junction compensation shall be self-contained, automatic, and shall be reference to 0°C (32°F).

**S8.4 Operation:**

**S8.4.1 Temperature Monitor Equipment**—When the equipment is operated under nominal conditions simulating shipboard service (see S11.3), equipment operation shall comply with the following:



(1) Individual visual alarm indicators light when associated test switch is operated (applicable to IC/A and IC/S equipment).

(2) Test, reset, and audible alarm cut out switches operate as required.

(3) Indicator reads required temperature when test and select (or indicate as applicable) switches are operated. Readout accuracy shall be in accordance with S8.1.2.

(4) Alarm indication activated with temperature sensor terminals open or short circuited, except instruments for thermocouple sensors need not detect a short.

**S8.4.2 Selective Temperature Readout Equipment**—When the equipment is operated under nominal conditions simulating shipboard service (see S11.3), equipment operation shall comply with the following:

(1) Accuracy of readout (see S8.1.2).

(2) Selector switch operates in accordance with S8.4.1(3).

(3) Indicator scale is driven to either extreme low or high with temperature sensor terminals open or short circuited.

**S8.4.3 Power Supply Requirements**—Equipment shall operate normally from type I power as defined in MIL-STD-1399, Section 300. Nominal power input voltage and frequency shall be 115 V, 60 Hertz (Hz), single phase. Power line transients and spikes with magnitudes, duration, repetition rates, and decay characteristics as specified in MIL-STD-1399, Section 300 shall not cause equipment damage or affect equipment operation. The maximum difference in indicator reading and alarm setting level at any voltage and frequency condition and nominal (115 V, 60 Hz) with the same input, shall not exceed  $\frac{1}{2}$  of 1 % of full scale on all ranges.

**S8.5 Warm-up Time**—Transducer output shall attain a value within  $\pm 1$  % of the steady-state output with no overshoot in excess of 1 %. Output shall reach this band in 30 min or less and shall remain in this band (see S11.4).

**S8.6 Inclination**—Maximum deviation of indication resulting from inclination shall not exceed 1.0 % (see S11.5).

**S8.7 Enclosure**—There shall be no evidence of water leakage into the equipment enclosure (see S11.6).

**S8.8 Insulation Resistance**—The insulation resistance shall be not less than 10 megohms between power input lines and ground (hull).

**S8.9 Shock**—The temperature monitoring equipment shall show no evidence of mechanical or electrical damage or loosening of parts, when exposed to shock in accordance with MIL-S-901.

**S8.9.1 Temperature Monitor and Readout Equipment (IC/A, IC/I, and IC/S)**—Operating controls shall not change status during shock. There shall be no transfer of switch or relay contacts or change in selector switch position during shock. After shock, without any adjustments, the equipment shall meet the following requirements:

(1) Alarm set point accuracy as specified in S8.1.1 (as applicable).

(2) Indicator accuracy in accordance with S8.1.2.

(3) Operation shall be in accordance with S8.4.

**S8.10 Vibration**—Temperature indicating and monitoring equipment shall operate in accordance with the requirements herein when exposed to type I environmental vibration of

MIL-STD-167-1. Equipment range and accuracy requirements shall be demonstrated during and after completion of vibration. Equipment shall show no evidence of mechanical or electrical damage or loosening of parts. Operating controls and relays shall not change status during vibration. There shall be no momentary or permanent transfer of switch or relay contacts or change in selector switch position during vibration.

**S8.11 Temperature**—Equipment shall operate in accordance with S8.4 when exposed to ambient temperature conditions from 0 to 65°C (32 to 149°F). The equipment shall not be damaged in a non-operating condition when exposed to ambient temperatures of -40 to 70°C (-40 to 158°F).

## **S9. Workmanship, Finish, and Appearance**

**S9.1 Cleaning and Surface Finishes**—Surfaces of castings, forgings, molded parts, stampings, machined and welded parts shall be free of defects such as cracks, porosity, undercuts, voids and gaps as well as sand, dirt, fins, sharp edges, scale, flux, and other harmful or extraneous materials. External surfaces shall be smooth and edges shall be either rounded or beveled. There shall be no burn-through. There shall be no warpage or dimensional change due to heat from welding operation. There shall be no damage to adjacent parts resulting from welding.

## **S10. Number of Tests and Retests**

S10.1 The number of tests and retests, if any, shall be specified in the acquisition requirements.

## **S11. Test Methods**

**S11.1 Calibration and Accuracy**—Monitor and readout equipment calibration and accuracy measurements shall be accomplished by simulating temperature sensor signal output over the designated temperature span. Simulated signal for equipment using the resistance sensing technique shall be resistance values as specified in Appendix B and shall be simulated by a resistance decade (or similar device) having an accuracy of  $\pm 0.055 \Omega$ . The simulated signal for equipment using the thermocouple sensing technique shall be millivolts (mV) as specified in ANSI C96.1 and shall be simulated by a stable direct current (dc) voltage source having an accuracy of  $\pm 0.025$  mV.

**S11.1.1 Accuracy of Alarm Set Point**—Alarm set points shall be calibrated and adjusted in accordance with the instructions contained in the technical manual furnished with the equipment. The accuracy of the alarm set point shall be checked at 5 different temperatures approximately equally spaced over the temperature span for each alarm channel. A signal simulating the temperature sensor output shall then be applied to the equipment input terminals. The accuracy of the alarm set point shall be checked with both increasing and decreasing signals. The signal required to actuate the alarm shall be within the limits specified in S8.1.1.

**S11.1.2 Accuracy of Readout**—The accuracy of the readout portion of equipment types shall be determined at approximately equally spaced intervals over each readout temperature span. The reading, at each simulated temperature input, shall be as specified in S8.1.2.



**S11.1.3 Lead Resistance Compensation**—For equipment which operates with RTE sensors, one of the measurements specified in S11.1.1 and S11.1.2 shall be repeated by inserting a resistance in series with each lead of the resistor simulating the RTE to simulate lead resistance. The resistance in each lead shall be any value between 20 and 30  $\sigma$ , but the resistance for each lead shall be equal to each other within 0.1  $\Omega$ .

**S11.2 Response Time:**

**S11.2.1 Alarm Circuits**—Compliance with S8.3.1 shall be demonstrated by testing at 10, 20, 50, 90, and 100 % of the full alarm setting range.

**S11.2.2 Temperature Readout**—A step input signal, equal to 80 % of the temperature span (from 10 to 90 % of the span) for each temperature range setting shall be applied to the temperature sensor input terminals. Indicator reading shall be as specified in S8.3.3.

**S11.3 Operation (Monitor and Readout Equipment)**—Equipment shall be energized with nominal voltage and frequency (115 V, 60 Hz) and allowed to stabilize for at least 30 min. Input signals, simulating temperature sensor outputs equivalent to approximately mid-range of the temperature span, shall be connected to all equipment input terminals. Equipment controls shall then be actuated in turn to verify compliance with S8.4.1 and S8.4.2. Indicator readings shall be noted and recorded. The supply voltage and frequency shall then be adjusted to the lower limit of permissible variation (see S8.4). Equipment shall be stabilized at this input power for at least 15 min and indicator reading shall be noted and recorded. Supply voltage and frequency shall then be adjusted to the higher limit, stabilized for at least 15 min, and the indicator reading noted and recorded. Temperature sensor inputs during these tests shall remain constant. The change in indicator reading, due to variations in input power shall be within the limits specified in S8.4.

**S11.4 Warm-up Time**—Test shall be conducted to determine the elapsed time between the application or line power to the equipment and the point at which the indication reaches the conditions specified in S8.5.

**S11.4.1** The transducer shall be placed in an ambient temperature of  $25 \pm 2^\circ\text{C}$  ( $77 \pm 3.6^\circ\text{F}$ ) for not less than 2 h de-energized. Recording equipment and other auxiliary equipment shall be energized to assure complete warm-up. A simulated signal equal to  $80 \pm 5\%$  of indication shall be applied and maintained constant during this test. Performance shall conform to S8.5.

**S11.5 Inclination**—The equipment shall be inclined for a period of at least 1 min in each of the following positions:

- (1) 45° forward
- (2) 45° backward
- (3) 45° to the left
- (4) 45° to the right

In each position a reference measurement (see S11.1) shall be made. Performance shall conform to S8.6.

**S11.6 Enclosure**—The enclosure shall be subjected to a solid stream of water from a 2.54 cm (1 in.) nozzle at 246 L (65 gal) per minute at a distance from the equipment of approximately 3.05 m (10 ft). The water stream shall be directed at all

surfaces of the enclosed equipment and its mounting surface for a minimum of 5 min. Performance shall conform to S8.7.

**S11.7 Insulation Resistance**—Insulation resistance shall be determined with a test potential of 50 Vdc applied for a minimum of 60 s.

**S11.8 Shock**—Equipment and sensor assemblies shall be tested in accordance with the high-impact shock test specified in MIL-S-901 for grade A, class I, type C equipment.

**S11.8.1 Monitor and Readout Equipment**—The equipment shall be energized during the test with nominal voltage and frequency (115 V, 60 Hz) and sensor input signals shall be 80 % of span. During the test, all operating controls shall be observed for change in status. After the shock test, equipment shall be subjected to the following examinations and tests:

- (1) Alarm set point accuracy (see S11.1.1),
- (2) Readout accuracy (see S11.1.2),
- (3) Operation at nominal voltage and frequency (see S11.3), and
- (4) Examination for evidence of mechanical damage or loosening of parts.

**S11.9 Vibration**—Equipment and sensor assemblies shall be tested in accordance with type I vibration of MIL-STD-167-1. Energization, input signals, observations during test and examinations after vibration shall be as specified in S11.8 for the shock test. IC/A system shall have the alarm point set within 4 % of full scale of the incoming temperature level. The temperature level shall be at 90 % of full scale. If an alarm occurs during vibration, any vibration test is a failure and corrective action is required. Frequency variation tests of MIL-STD-167-1 are required with the same settings. It shall be demonstrated that vibration from 1 to 50 Hz in accordance with MIL-STD-167-1 shall not cause alarm.

**S11.10 Temperature:**

**S11.10.1 Operating**—The equipment shall be subjected to the following temperature cycles:

Period (h)	Temperature ( $\pm 3^\circ\text{C}$ )	Environment
6	0°C (32°F)	Chamber
6	65°C (149°F)	Chamber
6	25°C (77°F)	Stable room or chamber

Cycle periods shall be measured from the time the temperature is stabilized. All tests within a 6-h period shall be continuous. Performance during and after the tests shall conform to S8.11.

**S11.10.2 Non-operating**—The equipment shall be held at each of the two temperature extremes for a period of 24 h. Performance after the test shall conform to S8.11.

**S12. Inspection**

**S12.1 Classification of Inspections**—The inspection requirements specified herein are classified as follows:

- (a) Qualification testing, and
- (b) Quality conformance testing.

**S12.2 Qualification**—Qualification tests shall be conducted at a laboratory satisfactory to the purchaser. Qualification tests shall consist of the general examination and the tests specified in Table S1 and shall be conducted on equipment produced with techniques and procedures normally used in production.

**TABLE S1 Qualification Testing (Monitor and Selective Temperature Readout Equipment)**

Examination and Test	Requirement	Test
General examination	---	S12.5
Calibration and accuracy	S8.1	S11.1
Response time	S8.3	S11.2
Operation (Monitor and Readout Equipment)	S8.4	S11.3
Warm-up time	S8.5	S11.4
Inclination	S8.6	S11.5
Enclosure	S8.7	S11.6
Insulation resistance	S8.8	S11.7
Shock	S8.9	S11.8
Vibration	S8.10	S11.9
Temperature	S8.11	S11.10

**S12.2.1 Qualification Sample—Monitor and Readout Equipment**—One sample of each type and temperature sensing technique with the maximum number of channels for which qualification is sought shall be submitted for examination and test.

**S12.2.1.1 Extent of Qualification**—Qualification of an equipment type will also be extended to equipment of the same design, type, and sensing technique, with lesser number of channels.

**S12.2.2 Test Routine**—Equipment submitted for qualification testing shall be subjected to the tests shown in Table S1 in the order listed. Failure of an equipment to comply with any of the requirements listed shall cause refusal to grant qualification.

**S12.2.3 Disposition of Qualification Samples**—Samples subjected to qualification testing shall be considered consumed and non-deliverable as part of the contract. Final disposition of qualification samples shall be specified in the acquisition requirements.

**S12.3 Quality Conformance Testing**—The sample equipment or sensor assemblies selected shall be subjected to the examinations and tests listed in Table S3. Examinations and tests shall be performed in the order listed.

**TABLE S2 Sampling for Quality Conformance Testing**

Lot Quantity	Sample Quantity	Nonconformance Quantity
7 and under	All	---
8 to 15	7	1
16 to 40	10	1
41 to 110	15	1
11 to 300	25	2
301 to 500	35	2
501 and over	50	3

**TABLE S3 Quality Conformance Testing**

Examination and Test	Requirement	Test
General examination	---	S12.5
Calibration and accuracy	S8.1	S11.1
Insulation resistance	S8.8	S11.7
Operation	S8.4	S11.3
Response time	S8.3	S11.2

**S12.3.1 Lot**—Equipment of the same type presented for quality conformance inspection at one time shall be considered a “lot.” The lot may include the entire contract quantity, or it

may be the production of any convenient time period. Each equipment shall be subjected to general examination and accuracy test.

**S12.3.2 Sampling**—A sample of equipment shall be selected from each lot in accordance with Table S2 and subjected to the examinations and tests specified in Table S3. If the number of nonconforming equipment in any sample exceeds the acceptance number for that sample, the lot represented by the sample shall be rejected.

**S12.4 Test Conditions**—Except for those tests where the following factors are the variables, tests shall be conducted with the equipment operating under the following conditions:

(1) The ambient temperature shall be  $25 \pm 3^\circ\text{C}$  ( $77 \pm 5.4^\circ\text{F}$ ), and the relative humidity shall be between 25 and 50 %.

(2) The supply voltage shall be 115 V nominal.

(3) The supply frequency shall be 60 Hz nominal.

**S12.5 General Examination**—The temperature monitoring equipment shall be given a thorough examination to determine that it conforms to this specification and the approved drawings with respect to material, finish, construction, assembly, dimensions, workmanship, marking, identification, and information plates. This examination shall be limited to those examinations that may be performed without disassembling the unit in such a manner that its performance, durability and appearance would be affected. This examination shall include a mechanical check of all operating controls and adjustments, as applicable.

### S13. Certification

**S13.1** When specified in the purchase order or contract, the purchaser shall be furnished certification that samples representing each lot have been either tested or inspected as directed in this specification and the requirements have been met. When specified in the purchase order or contract, a report of the test result shall be furnished. It is recommended that all test data remain on file for three years at the manufacturer’s facility for review by purchaser upon request.

### S14. Product Marking

**S14.1** Product marking requirements shall be specified in the acquisition requirements.

### S15. Packaging and Package Marking

**S15.1** Packaging and package marking shall be in accordance with Section 15.

### S16. Quality Assurance Provisions

**S16.1 Warranty**—Special warranty requirements shall be specified in the acquisition requirements. Otherwise, the standard commercial warranty applies.

## SIGNAL CONDITIONER AND POWER SUPPLY (ELECTRICAL) (NAVAL SHIPBOARD USE)

The following supplementary requirements established for U.S. Naval shipboard application shall apply when specified in the contract or purchase order. When there is conflict between the standard (ASTM F2362) and this supplement's appendix, the requirements of this supplement's appendix shall take precedence for equipment acquired by this supplement's appendix. This document supercedes MIL-T-24387, Temperature Measurement Equipment Signal Conditioner and Power Supply (Electrical) for new ship construction.

### S17. Scope

S17.1 This specification covers the requirements for signal conditioners and electrical power supplies used in conjunction with thermocouples and resistance temperature element assemblies for naval ships. It does not include the design of the sensing elements and wells or the requirements for the readout or display.

S17.2 This specification defines equipment intended to provide control input and monitoring of temperatures for shipboard engineering plants.

S17.3 The U.S. Government preferred system of measurement is the metric SI system. However, since this item was originally designed using inch-pound units of measurement, in the event of conflict between the metric and inch-pound units, the inch-pound units shall take precedence.

### S18. Referenced Documents

#### S18.1 Commercial Documents:

ANSI/ASQC Q9001-1994 Quality Systems—Model for Quality Assurance in Design, Development, Production, Installation, Inspection, Testing and Servicing<sup>5</sup>

#### S18.2 Government Documents:<sup>6</sup>

##### S18.2.1 Military Standard:

MIL-STD-167-1 Mechanical Vibrations of Shipboard Equipment (Type I—Environmental and Type II—Internally Excited)

##### S18.2.2 Military Specifications:

MIL-S-901 Shock Tests, H.I. (High-Impact); Shipboard Machinery, Equipment and Systems, Requirements for

MIL-J-24142 Junction Boxes for Electrical Fittings and Fixtures, General Specification for

MIL-J-24142/3 Junction Box, Submersible, Size 6 by 9

### S19. Terminology

#### S19.1 Definitions:

S19.1.1 *thermocouple*, shall be as defined by S34.

S19.1.2 *resistance*, shall be as defined by Section S34.

S19.1.3 *deadband*, the range through which the measurand can be verified without a change in output.

S19.1.4 *static error band*, the maximum deviation from a straight line drawn through the coordinates of the lower span limit at specified output, and the upper span limit at specified output expressed in percent of span.

### S20. Classification

Temperature monitoring equipment shall consist of a series of designations which shall be assigned and listed in the format below.

Example: ASTM F2362S17-TRE-4H-YES

Specification	Type	Input Range	Alarm and Repeater Circuits
F2362S17	TRE	4H	YES
	S20.1	S20.2	

S20.1 *Type*—Temperature measurement equipment shall be designated by the three letter symbols as follows:

TRE—Temperature Resistance Equipment, platinum

TTE—Temperature Thermocouple Equipment, type K

S20.2 *Input Range*—The temperature range in degrees Fahrenheit (°F) shall be designated by its numerical value (see S20.2.1.1 and S20.2.2.1).

#### S20.2.1 Temperature Resistance (Type TRE) Input:

S20.2.1.1 *Ranges*—Equipment temperature range shall be as specified in the acquisition requirements. Ranges shall be in accordance with the following:

Range	Designation
-40 to 127°C (-40° to 260°F)	26
-18 to 205°C (0° to 400°F)	4H
-18 to 538°C (0° to 1000°F)	1K

S20.2.1.2 *Excitation Current*—The maximum current through the resistance temperature element shall be 6 ma, dc.

S20.2.1.3 *Lead Wire Resistance Compensation*—The equipment input for resistance sensing technique shall be of three-wire configuration. A means shall be provided to compensate for the factors which introduce error such as self heating and the resistance of interconnecting wiring between the sensor and signal conditioner.

#### S20.2.2 Temperature Thermocouple (Type TCE) Input:

S20.2.2.1 *Ranges*—Equipment temperature range shall be as specified in the acquisition requirements. Ranges shall be in accordance with the following:

Range	Designation
-40 to 93°C (-40° to 200°F)	2H
-18 to 205°C (0° to 400°F)	4H
-18 to 538°C (0° to 1000°F)	1K
205 to 649°C (400° to 1200°F)	12H
260 to 816°C (500° to 1500°F)	15H

S20.2.2.2 *Cold Junction Compensation*—Cold junction compensation for thermocouple sensing technique shall be automatic and shall be referenced to 0°C (32°F).

### S21. Ordering Information

S21.1 The purchaser shall provide the manufacturer with all of the pertinent application data shown in accordance with S21.2. If special application operating conditions exist that are not shown in the acquisition requirements, they shall also be described.

<sup>5</sup> Available from American National Standards Institute (ANSI), 25 W. 43rd St., 4th Floor, New York, NY 10036.

<sup>6</sup> Available from Standardization Documents Order Desk, DODSSP, Bldg. 4, Section D, 700 Robbins Ave., Philadelphia, PA 19111-5098.



**S21.2 Acquisition Requirements**—Acquisition documents should specify the following:

- (1) Title, number and date of this specification,
- (2) Classification required,
- (3) Quantity of units required,
- (4) Type of enclosure mounting,
- (5) Power requirements,
- (6) Equipment temperature ranges,
- (7) Disposition of qualification test samples,
- (8) Product marking requirements, and
- (9) Unique preservation, packaging, and marking requirements.

## **S22. Materials and Manufacture**

**S22.1** Except where specifications are referenced, materials shall be in accordance with commercial specifications having material compositions suitable for service in the shipboard marine environment.

## **S23. Physical Properties**

**S23.1 Description**—The equipment specified herein in conjunction with the thermocouples or resistance temperature elements specified in Appendix B comprise a temperature instrument. The temperature measurement equipment generally consists of the following units:

- (1) *Signal Conditioner*—The signal conditioner shall convert the sensing element output to a continuous linear analog signal directly proportional to temperature.
- (2) *Power Supply*—The power supply shall provide excitation energy to the signal conditioner and sensor.
- (3) *Test Device*—A test device shall be furnished to provide a calibrated test signal used for calibrating the equipment.

The various assemblies of temperature measurement equipment shall be built integrally together and housed in the same enclosure.

**S23.2 Output**—The electrical signal output of the equipment shall be dc, directly proportional to temperature input. The output shall be 4 to 20 ma, dc into an external resistance of  $550 \pm 10\% \sigma$ .

**S23.3 Calibration Means**—A means shall be provided to monitor equipment output corresponding to temperature input to permit in place calibration by one man. Each temperature instrument shall contain a test switch and a temperature detector simulator capable of supplying a test signal into the instrument circuitry. This test device shall have a calibrated dial and shall replace the detector when the instrument is in the test mode. The signal from this simulator shall be of sufficient accuracy to determine static error band (see S24.2) and repeatability (see S24.3). Test jacks shall be provided to monitor the equipment output and detector output. Placing the instrument in the test mode shall allow remote monitoring of the detector. Calibration shall be effected without the necessity of electrical disconnection.

**S23.4 Equipment Range**—Equipment range shall be determined by means of an interchangeable assembly or internal adjustments.

**S23.5 Adjustments**—Tamper-proof adjustments for zero and span shall be provided for calibration purposes. The number of adjustments shall be kept to a minimum, consistent with the

operation and maintenance of the equipment and the elimination for the selective matching of parts.

**S23.6 Fail Safe Output**—If the input of the signal conditioner is open circuited, the output shall drive upscale or downscale, the choice of which shall be made by means of a link.

**S23.7 Isolation**—Input and output circuits shall be isolated from each other and from ground.

**S23.8 Enclosure**—Temperature measurement equipment shall be mounted in a junction box. The junction box may be in accordance with MIL-J-24142 and MIL-J-24142/3. At a minimum, the size, mounting, and cable interface shall be per MIL-J-24142 and MIL-J-24142/3. All adjustments and test points shall be accessible when the cover is removed. Temperature measurement equipment shall be designed for bulk-head or bracket mounting.

**S23.9 Weight**—The weight of the complete equipment shall be kept to a minimum commensurate with good engineering design.

**S23.10 Power Supply Requirements**—The equipment shall be designed to operate with line variations as specified in S27.9 and S27.12. Nominal steady state power supply requirements shall be  $115 \pm 10\% V$  at  $60 \pm 5\% \text{ hertz (Hz)}$ , single phase, unless otherwise specified in the acquisition requirements.

**S23.11 Cable Entrance and Connection**—Cable entrance shall be by means of stuffing tubes located on the bottom surface of the enclosure.

**S23.12 Operation**—The operation of the equipment shall not depend on balancing motor, slide wires, or similar devices. The system shall be completely static. The use of potentiometers are for test and adjustment purposes only.

**S23.13 Resistors**—Composition type fixed or variable resistors shall not be used.

**S23.14 Batteries**—Batteries shall not be used.

**S23.15 Modular Assemblies**—Modular units or assemblies shall be fastened in such a manner to allow for quick and easy removal for maintenance accessibility or replacement.

**S23.16 Terminal Boards**—The interface with shipboard wiring shall be by means of terminal boards. These terminals shall be accessible with the coverplate removed.

## **S24. Performance Requirements**

Performance tolerances are expressed in percent of equipment span unless stated otherwise.

**S24.1 Service Life**—Equipment shall be designed for a minimum service life of 40 000 h in a shipboard marine environment.

**S24.2 Static Error Band**—The static error band shall not exceed plus or minus 1 % (see S27.2).

**S24.3 Repeatability**—Repeatability of the output shall not exceed 0.3 % (see S27.2).

**S24.4 Threshold and Deadband**—The maximum least detectable increment plus deadband shall not exceed 0.2 % (see S27.4).

**S24.5 Ripple**—Equipment output ripple shall not exceed 0.15 % of full scale output (see S27.5).

S24.6 *Warm-up Time*—The equipment output shall attain a value within plus or minus 1 % of the steady state output with no overshoot in excess of 1 %. Output shall reach this band in 30 min or less and shall remain in this band (see S27.6).

S24.7 *Inclination*—Maximum deviation of equipment output resulting from inclination shall not exceed 1.0 % (see S27.7).

S24.8 *Input Resistance*—The equipment output shall remain within the static error band (see S24.2 and S27.8).

S24.9 *Supply Voltage and Frequency (Steady State)*—Maximum difference between outputs at any voltage and frequency condition and the normal (115 V, 60 Hz) at the same input shall not exceed 1.0 % (see S27.9).

S24.10 *Response Time*—The 95 % response time shall be 0.5 s or less (see S27.10).

S24.11 *Supply Voltage and Frequency (Transients)*:

S24.11.1 *Voltage*—When the equipment is exposed to the limits of specified voltage transient, the equipment output shall remain within  $\pm 1$  % of the steady state output (see S27.11).

S24.11.2 *Frequency*—When the equipment is exposed to the limits of specified frequency transient, the equipment output shall remain within  $\pm 1$  % of the steady state output (see S27.11).

S24.12 *Temperature*—When the equipment is exposed to the ambient temperature extremes, performance shall be within the static error band specified in S24.2 (see S27.12).

S24.13 *Insulation Resistance*—The insulation resistance of the equipment between circuits and between circuits and ground shall be not less than 10 megohms (see S27.13).

S24.14 *Vibration*—When the equipment is exposed to vibration in accordance with MIL-STD-167-1, monitored output test shall show no variation from steady state output in excess of 2.0 %. There shall be no visible evidence of damage to the equipment as a result of the vibration (see S27.14).

S24.15 *Shock*—After exposure to shock in accordance with MIL-S-901 but prior to any adjustment, the equipment output shall show no deviation greater than 3 %. A post shock calibration, using adjustments provided, shall conform to performance requirements of S24.2. There shall be no visual evidence of damage to the equipment as a result of the shock (see S27.15).

## S25. Workmanship, Finish, and Appearance

S25.1 *Cleaning and Surface Finishes*—Surfaces of castings, forgings, molded parts, stampings, machined and welded parts shall be free of defects such as cracks, porosity, undercuts, voids and gaps as well as sand, dirt, fins, sharp edges, scale, flux, and other harmful or extraneous materials. External surfaces shall be smooth and edges shall be either rounded or beveled. There shall be no burn-through. There shall be no warpage or dimensional change due to heat from welding operation. There shall be no damage to adjacent parts resulting from welding.

## S26. Number of Tests and Retests

S26.1 The number of tests and retests, if any, shall be specified in the acquisition requirements.

## S27. Test Methods

S27.1 *General Examination and Operation*—The unpowered temperature monitoring equipment shall be given a thorough examination to determine conformance to the requirements of this specification with respect to material, color, finish, workmanship, safety, construction, assembly, dimensions, weight, and marking of identification plates. Examination shall be limited to the examinations that may be performed without disassembling the unit in such a manner that its performance, durability, or appearance would be affected.

S27.2 *Static Error Band and Repeatability*—Prior to the start of this test, the test sample and associated test equipment shall be energized for a period of 2 h. The test sample shall first be cycled over its full temperature range by slowly increasing and decreasing the input for six continuous cycles. The calibration measurements shall be made at a minimum of 5 equally spaced intervals over the entire range (both upscale and downscale). Precaution shall be taken to avoid overshoot. This calibration procedure shall be applied three successive times to determine repeatability. Static error band of all calibrations shall meet the requirements of S24.2. Repeatability shall meet the requirements of S24.3.

S27.3 *Reference Measurement*—A one trial calibration with at least five equally spaced intervals over the entire input range both upscale and downscale shall be conducted when specified in the individual test.

S27.4 *Determination of Threshold and Deadband*—Threshold and deadband shall be determined with  $80 \pm 5$  % of the temperature span applied to the test sample. The temperature interval beyond this point required to produce a detectable change in output and the temperature interval in the opposite direction to return the output to the original value shall be determined in each direction. Threshold is the first temperature interval. The second temperature interval is the sum of the threshold and deadband. Performance shall conform to the requirements of S24.4.

S27.5 *Ripple-equipment Output*—Ripple shall be determined at an input of  $80 \pm 5$  % of the temperature span. Performance shall conform to the requirements of S24.5.

S27.6 *Warm-up Time*—This test shall be conducted to determine the elapsed time between the application of line power to the test sample and the point at which the equipment output reaches the conditions specified in S24.6. The test sample shall be placed in an ambient temperature of  $25 \pm 2^\circ\text{C}$  ( $77 \pm 3.6^\circ\text{F}$ ) for not less than 2 h de-energized. Recording equipment and other auxiliary equipment shall be energized to assure complete warm-up. An input of  $80 \pm 5$  % of the span is to be applied to the test sample and maintained constant during this test. Performance shall conform to S24.6.

S27.7 *Inclination*—The equipment shall be inclined for a period of at least 1 min in each of the following positions:

- (1) 45 degrees forward
- (2) 45 degrees backward
- (3) 45 degrees to the left
- (4) 45 degrees to the right

In each position a reference measurement (see S27.3) shall be made. Performance shall conform to S24.7.

**S27.8 Input Resistance**—For thermocouple sensing technique, a noninductive resistance of  $150 \pm 1\% \Omega$  shall be placed in each lead to the input terminals to total a circuit resistance of approximately  $300 \Omega$ . A reference measurement (see S27.3) shall be made. Performance shall conform to S24.8.

**S27.9 Supply Voltage and Frequency (Steady State)**—The equipment shall be operated at the various combinations of normal, maximum and minimum steady state voltages and frequencies outlined in S24.9. The equipment shall be operated at least 15 min in each combination during which time a reference measurement (see S27.3) shall be taken. Performance shall conform to S24.9.

**S27.10 Response Time**—A step input equal to 10 to 90 % of full scale equipment temperature span shall be applied to the test sample. Performance shall conform to S24.10.

**S27.11 Supply Voltage and Frequency (Transient)**—The tests specified in S27.11.1 through S27.11.2 shall be conducted with a temperature input signal equal to  $80 \pm 5\%$  of the input span. Performance shall conform to S24.11.

**S27.11.1 Transient Voltage**—With the equipment operating on the upper limit of steady voltage, a transient voltage of plus 20 % of nominal voltage recovering to the steady state band in 2 s shall be superimposed. With the equipment operating on the lower limit of steady state voltage, transient voltage of minus 20 % of nominal voltage recovering to the steady state band in 2 s shall be superimposed.

**S27.11.2 Transient Frequency**—With the equipment operating at the nominal frequency, a transient frequency of 2 Hz shall be applied of which not more than  $\frac{1}{2}$  cycle per second is outside the steady state tolerance band recovering to the steady state tolerance band within 2 s. This shall be repeated with a minus 2 Hz transient frequency.

**S27.12 Temperature**—The equipment shall be capable of normal operation (without alignment or adjustment) other than the accessible controls employed for operation of the equipment) throughout the following temperature cycle; tolerances in operating characteristics shall be as specified in the individual equipment specification.

(1) Hold room temperature at  $0 \pm 2^\circ\text{C}$  ( $32 \pm 3.6^\circ\text{F}$ ) for at least 24 h.

(2) Increase room temperature in steps of  $10^\circ\text{C}$  ( $18^\circ\text{F}$ ) each, at 30 min per step, until  $65 \pm 2^\circ\text{C}$  ( $149 \pm 3.6^\circ\text{F}$ ) is reached, and hold at that temperature for at least 4 h.

(3) Reduce room temperature in steps of  $10^\circ\text{C}$  ( $18^\circ\text{F}$ ) each, at 30 min per step, until  $25 \pm 2^\circ\text{C}$  ( $77 \pm 3.6^\circ\text{F}$ ) is reached, and hold at that temperature for at least 4 h. At each temperature plateau  $0^\circ\text{C}$  ( $32^\circ\text{F}$ ),  $65^\circ\text{C}$  ( $149^\circ\text{F}$ ) and  $25^\circ\text{C}$  ( $77^\circ\text{F}$ ), a reference measurement (see S27.3) shall be made. Performance shall conform to S24.12.

**S27.13 Insulation Resistance**—The insulation resistance of the equipment shall be determined by applying 50 V dc between electrical input and output circuits and between these circuits and ground (see S24.13).

**S27.14 Vibration**—The equipment shall be tested in accordance with type I (environmental vibration) of MIL-STD-167-1 except that the upper limit of the frequency range shall be 100 Hz. The amplitudes of vibration shall be in accordance with Table S4. If no resonances are observed, the 2 h endurance test shall be conducted at 100 Hz. During the vibration test, an input equal to  $80 \pm 5\%$  of the temperature span shall be applied to the test sample. The output during the test shall be monitored. Performance shall conform to S24.14.

**TABLE S4 Amplitudes of Vibration**

Frequency Range, (Hz)	Table Amplitude, $\mu\text{m}$ (in.)
5 to 20	$762 \pm 150$ ( $0.030 \pm 0.006$ )
21 to 50	$500 \pm 100$ ( $0.020 \pm 0.004$ )
51 to 100	$250 \pm 50$ ( $0.010 \pm 0.002$ )

**S27.15 Shock**—The shock test shall be conducted in accordance with MIL-S-901, grade A, class I, type C. During the test an input equal to  $80 \pm 5\%$  of the temperature span shall be applied to the equipment. The test sample output during the test shall be monitored. Before and after this test, reference measurements shall be made for comparison (see S27.3). Performance shall conform to S24.15.

## S28. Inspection

The testing set forth in this specification shall become a part of the manufacturer's overall inspection system or quality program. The manufacturer's quality system shall comply with the requirements of ANSI/ASQC 9001-1994, Quality Systems—Model for Quality Assurance in Design, Development, Production, Installation, and Servicing. Certification and registration is highly desired but not required.

**S28.1 Classification of Inspections**—The inspection requirements specified herein are classified as follows:

- (1) Qualification testing, and
- (2) Quality conformance testing.

**S28.2 Test Conditions**—Except where the following factors are the variables, the tests shall be conducted with the equipment operating under the following conditions:

- (1) Ambient temperature shall be  $24 \pm 5^\circ\text{C}$  ( $75 \pm 9^\circ\text{F}$ ),
- (2) Relative humidity shall be  $60 \pm 15\%$ ,
- (3) Supply voltage shall be nominal, and
- (4) Supply frequency shall be nominal.

**S28.3 Qualification Testing**—The qualification testing shall consist of the tests specified in Table S5. The tests shall be performed in the sequence shown.



**TABLE S5 Qualification Testing**

Examination and Test	Requirement	Test
General examination	---	S27.1
Output	S24.4	S27.2
Static error band and repeatability	S24.2	S27.2
Reference measurement	S24.3	S27.3
Threshold and deadband	S24.4	S27.4
Ripple	S24.5	S27.5
Warm-up time	S24.6	S27.6
Inclination	S24.7	S27.7
Input resistance	S24.8	S27.8
Supply line voltage and frequency, steady-state	S24.9	S27.9
Response time	S24.10	S27.10
Supply line voltage and frequency, transients	S24.11	S27.11
Temperature	S24.12	S27.12
Insulation resistance	S24.13	S27.13
Vibration	S24.14	S27.14
Shock	S24.15	S27.15

S28.3.1 *Sample Size*—The number of samples subjected to qualification tests as specified in Table S5 shall depend on the equipment design. If each range is covered by a separate and distinct design, a sample for each range will require testing. Only one sample of a basically similar design series which may cover many ranges need be tested if mechanical and electrical similarity is deemed sufficient by the purchaser.

S28.4 *Quality Conformance Testing*—All temperature measurement equipment offered for delivery shall be subjected to the examination and tests listed in Table S6 and shall be conducted in the order listed. Failure of any temperature equipment to meet the requirements of this specification shall be cause for rejection.

**TABLE S6 Quality Conformance Testing**

Examination and Test	Requirement	Test
General examination	---	S27.1
Output	S24.4	S27.2
Static error band and repeatability	S24.2	S27.2
Ripple	S24.5	S27.5
Input resistance	S24.8	S27.8
(thermocouple sensing technique only)		
Insulation resistance	S24.13	S27.13

## S29. Certification

S29.1 When specified in the purchase order or contract, the purchaser shall be furnished certification that samples representing each lot have been either tested or inspected as directed in this specification and the requirements have been met. When specified in the purchase order or contract, a report of the test result shall be furnished. It is recommended that all test data remain on file for three years at the manufacturer's facility for review by purchaser upon request.

## S30. Product Marking

S30.1 Product marking requirements shall be specified in the acquisition requirements but at a minimum, shall include:

- (1) Manufacturer's name,
- (2) Classification, and
- (3) Signal conditioner.

## S31. Packaging and Package Marking

S31.1 Packaging and package marking shall be in accordance with Section 15.

## THERMOCOUPLE AND RESISTANCE TEMPERATURE DETECTOR ASSEMBLIES (NAVAL SHIPBOARD USE)

The following appendix to supplementary requirements established for U.S. Naval shipboard application shall apply when specified in the contract or purchase order. When there is conflict between the standard (ASTM F2362) and this supplement's appendix, the requirements of this supplement's appendix shall take precedence for equipment acquired by this supplement's appendix. This document supercedes MIL-T-24388, Thermocouple and Resistance Temperature Detector Assemblies, General Specification for (Naval Shipboard), for new ship construction.

### S32. Scope

S32.1 This specification covers environmentally hardened resistance thermometers and thermocouple sensors that transform the surrounding thermal energy in a manner that can be electrically measured and converted to a temperature using a signal conditioner/temperature monitor. Types of configurations covered in this specification are those which place the resistance thermometer or thermocouple sensor directly into the medium (bare bulb), into a thermowell, or embedded into a bearing.

S32.2 Resistance thermometers and thermocouple sensors are intended to convert temperature measured to an electrical output for input to a temperature signal conditioner.

S32.3 The U.S. Government preferred system of measurement is the metric SI system. However, since this item was originally designed using inch-pound units of measurement, in the event of conflict between the metric and inch-pound units, the inch-pound units shall take precedence.

### S33. Referenced Documents

#### S33.1 *Commercial Documents:*

##### S33.1.1 *ASTM Standards:*<sup>7</sup>

A249 Specification for Welded Austenitic Steel Boiler, Superheater, Heat Exchanger, and Condenser Tubes

A269 Specification for Seamless and Welded Austenitic Stainless Steel Tubing for General Service (DOD adopted)

A276 Specification for Stainless and Heat-Resisting Steel Bars and Shapes (DOD adopted)

A312 Specification for Seamless and Welded Austenitic Stainless Steel Pipe (DOD adopted)

B23 Specification for White Metal Bearing Alloys Known Commercially as “Babbitt Metal”

B117 Method of Salt Spray (Fog) Testing (DOD adopted)

B152 Specification for Copper Sheet, Strip, Plate, and Rolled Bar (DOD adopted)

B164 Specification for Nickel-Copper Alloy Rod, Bar, and Wire (DOD adopted)

B167 Specification for Nickel-Chromium-Iron Alloys (UNS N06600 and N06690) Seamless Pipe and Tube (DOD adopted)

B355 Specification for Nickel-Coated Soft or Annealed Copper Wire (DOD adopted)

B637 Specification for Precipitation-Hardening Nickel Alloy Bars, Forgings, and Forging Stock for High Temperature Service

D1457 Specification for Polytetrafluoroethylene PTFE Molding and Extrusion Materials (DOD adopted)

**E344** Terminology Relating to Thermometry and Hydrometry

#### S33.2 *Government Documents:*<sup>8</sup>

##### S33.2.1 *Military Standards:*

MIL-STD-167-1 Mechanical Vibrations of Shipboard Equipment (Type I—Environmental and Type II—Internally Excited)

MS 3102 Connector, Receptacle, Electric, Box Mounting, Solder Contacts, AN

MS 3106 Connector, Plug, Electric, Straight, Solder Contacts, AN Type

##### S33.2.2 *Military Specifications:*

MIL-S-901 Shock Tests, HI (High-Impact); Shipboard Machinery, Equipment and Systems, Requirements for

MIL-W-5846 Wire, Electric, Chromel, and Alumel, Thermocouple

MIL-A-8625 Anodic Coating, for Aluminum and Aluminum Alloys

MIL-W-16878 Wire, Electrical, Insulated, General Specification for

MIL-W-16878/4 Wire, Electrical, Polytetrafluoroethylene (PTFE) Insulated, 200 °C, 600 V, Extruded Insulation

MIL-W-16878/25 Wire, Electrical, Polytetrafluoroethylene (PTFE) Insulated, 260 °C, 600 V, Extruded Insulation

MIL-W-81381 Wire, Electric, Polyimide-Insulated, Copper or Copper Alloy

MIL-W-81381/12 Wire, Electric, Fluorocarbon/Polyimide Insulated, Medium Weight, Nickel Coated Copper Conductor, 600 V, 200 °C, Nominal 8.4 or 15.4 MIL WALL

### S34. Terminology

S34.1 *Definitions*—Definitions and terminology shall be in accordance with Terminology **E344**.

### S35. Classification

S35.1 *Design Type*—Resistance thermometers and thermocouple sensors shall be classified according to the following variables:

Example: ASTM F2362S32-KTC-TW-S7

Specification	Type	Configuration	Designation Number
F2362S32	KTC (see S35.2)	TW (see S35.3)	S7 (see S35.4)

S35.2 *Type*—The type of resistance thermometer or thermocouple sensor shall be designated by one of the following three-letter symbols:

Type	Symbols
Type K thermocouple sensor	KTC
Resistance thermometer with nickel element	NRT
Resistance thermometer with platinum element	PRT

S35.3 *Configuration*—Type of configuration for which the resistance thermometer or thermocouple sensor is intended shall be designated by one of the following two-letter symbols:

Type of Configuration	Symbols
Thermowell	TW
Bare bulb	BB
Embedded	EM

S35.4 *Designation Number*—The designation number used to specify the sheath length and other applicable parameters within each type of configuration shall be denoted by one or two numerals or by one or two numerals preceded by a letter found in one of the following:

Type of Configuration	Table Number
TW	S7
BB	S8
EM	S9

### S36. Ordering Information

S36.1 The purchaser shall provide the manufacturer with all of the pertinent application data shown in accordance with S36.2. If special application operating conditions exist that are not shown in the acquisition requirements, they shall also be described.

S36.2 *Acquisition Requirements*—Acquisition documents should specify the following:

- (1) Title, number, and date of this specification,
- (2) Classification required,
- (3) Design type,
- (4) Range,
- (5) Quantity required,
- (6) When qualification testing is required,
- (7) Disposition of qualification test samples,
- (8) Product marking requirements, and
- (9) Packaging requirements.

<sup>7</sup> For referenced ASTM standards, visit the ASTM website, [www.astm.org](http://www.astm.org), or contact ASTM Customer Service at [service@astm.org](mailto:service@astm.org). For *Annual Book of ASTM Standards* volume information, refer to the standard’s Document Summary page on the ASTM website.

<sup>8</sup> Available from Standardization Documents Order Desk, DODSSP, Bldg. 4, Section D, 700 Robbins Ave., Philadelphia, PA 19111-5098.

### S37. Materials and Manufacture

S37.1 *Materials*—Recommended materials of resistance thermometer and thermocouple sensor components are provided in Table S7.

S37.1.1 *Nonmetallic Materials*—Nonmetals, when used for seals, protective finishes, and so forth, shall be moisture and flame resistant, shall not support fungus growth, and shall not be adversely affected by the ambient environments specified in the performance requirements of this specification.

S37.1.2 *Connecting Wire and End Closure*—The connecting wire and end closure shall be airtight, nonhygroscopic, fungus resistant, flame resistant, and able to form a chemical bond with connecting wires (thermowell configuration), electrical connector receptacle pins, (bare bulb configuration), or the connecting wire insulation (embedded configuration) and with the sheath sufficient to meet the sealing requirements. The connecting wire end closure shall not chemically react, degrade, or outgas when subjected to the following: air,

distilled water, sea water, salt, petroleum and silicone based oils, oil solvents, prolonged (greater than 1 month) periods of exposure to ambient temperatures, prolonged periods of exposure to elevated temperatures up to 205°C (400°F), and exposure to prolonged cycling periods from ambient to elevated temperatures. A connecting wire and enclosure consisting of a ceramic-to-metal or a glass-to-metal seal shall also incorporate other characteristics to make it impenetrable to fluids and shall be considered a hermetic seal. The connecting wire end closure shall meet all the performance requirements specified in S39, including the connecting wire end closure requirement (see S42.8).

S37.1.3 *Fungus-inert Materials*—Materials which provide a nutrient medium for fungus and insects shall not be used in the construction of any resistance thermometer or thermocouple sensor.

S37.1.4 *Restricted Materials*—Cadmium or cadmium-plated parts shall not be used.

**TABLE S7 Materials**

Part	Configuration	Material	Material Specification	Remarks
Babbitt topping	EM	Babbitt	ASTM B23, grade 2	
Connecting wire resistance thermometer	TW	22 AWG, stranded nickel-plated copper	MIL-W-16878 and MIL-W-16878/25	
	BB	PTFE insulated 22 AWG, stranded nickel-plated copper	ASTM D1457 ASTM B355	
	EM	24 AWG, stranded nickel-plated or silver-plated copper	MIL-W-81381 and MIL-W-81381/12 or MIL-W-16878 and MIL-W-16878/4	
Connecting wire thermocouple sensor	TW	22 AWG, type K PTFE insulated	MIL-W-5846 ASTM D1457	
	BB	22 AWG, type K	MIL-W-5846	
	EM	24 AWG, type K fluorocarbon/polyimide insulated	MIL-W-81381/12	Conductors IAW MIL-W-5846 and no plating
Connection head cap	TW	Aluminum 356751	MIL-A-8625, type 1; 356 T6	Clear anodized
Connection head extension	TW	304 SST	ASTM A312	
Connection head	TW	Aluminum	MIL-A-8625, type 1; 356 T6	Clear anodized
identification plate		302 set	MIL-P-15024	
Gasket	BB	Copper	ASTM B152	Temper 0
Pins, connector	BB:PRT	Nickel-plated copper	MS 3102R-14S-7S	Receptacle Plug
Receptacle plug			MS 3106F-14S-7P	
	BB:NRT	Nickel-plated copper	MS 3102-R-12S-3P	Receptacle Plug
	BB:KTC	(+)chromel (-)alumel	MS 3106F-12S-3S	
Seal, ceramic to metal wire end enclosure	BB	Glass to metal epoxy		
Sheath	EM			
	TW	316 SST or Inconel	ASTM A249 ASTM A269 ASTM B167 ASTM B164	Required for type KTC
	BB	UNS NO4405		
	EM	99 % pure copper		1 % not restricted
Sheath, internal insulation	BB,TW:	Aluminum Oxide or Magnesium Oxide	Chemical certification on file required	99.8 % pure, MgO 94 % for KTC
	NRT,PRT,KTC			
Spring, compression	TW	Inconel	ASTM B637	Inconel, including grade 600
Spring stop	TW	300 Series SST	ASTM A249 ASTM A269 ASTM A276 ASTM B167	
Threaded fasteners	TW	Corrosion-resistant steel	ASTM A276	(1)
Washers	TW	316 SST	ASTM A276	



**S38. Physical Properties**

S38.1 *Construction*—Resistance thermometers and thermocouple sensors are shown on Figs. S1.0-S6.0. Resistance thermometer and thermocouple sensor construction dimen-

sions and application temperatures for thermowell, bare bulb, and embedded configurations shall be in accordance with Table S8, Table S9, and Table S10 respectively.

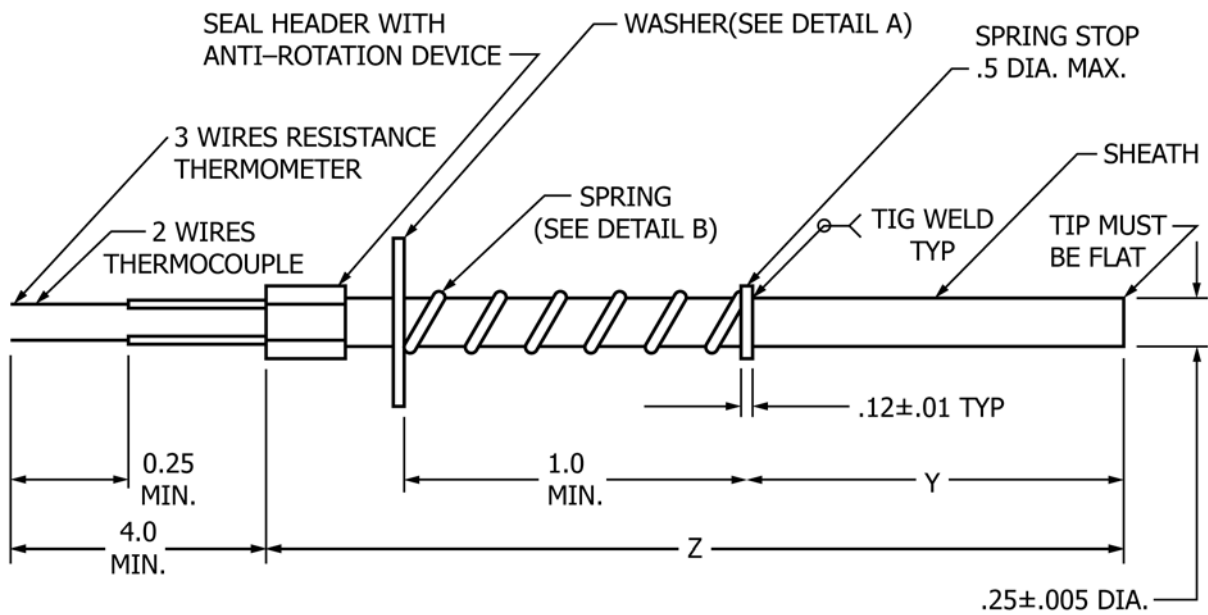

NOTE: ALL DIMENSIONS ARE IN INCHES

NOTE: SPRING SHALL PRODUCE A 5 LB FORCE WHEN COMPRESSED 3/16"

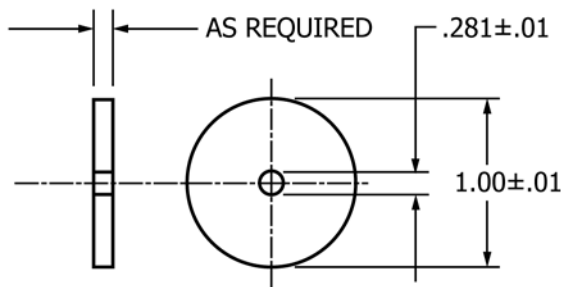

DETAIL A. WASHER

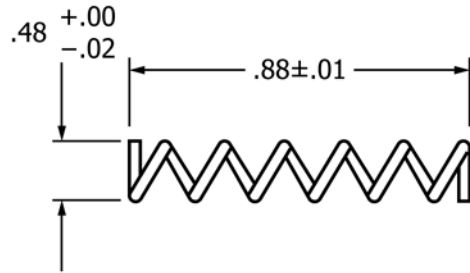

DETAIL B. UNCOMPRESSED SPRING LENGTH

NOTE 1—Dimensions and tolerances are reference only to meet installation requirements.

FIG. S1.0 Resistance Thermometer/Thermocouple Sensor Construction

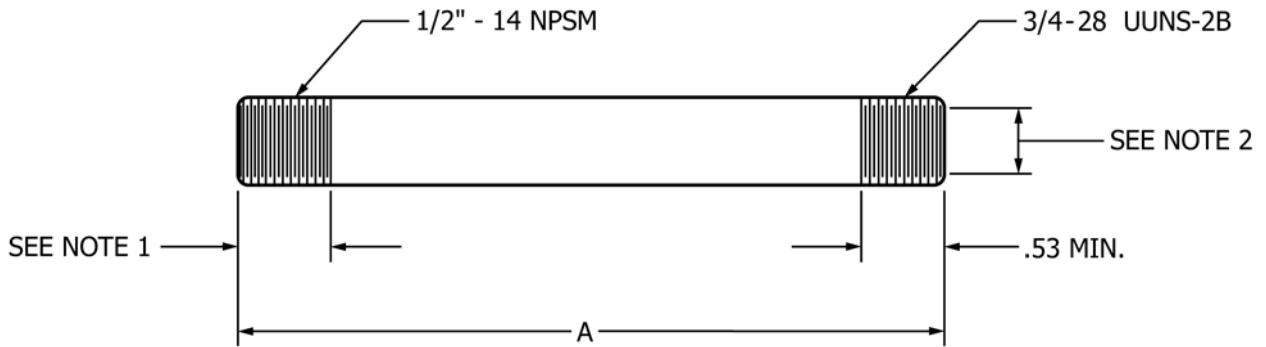

- NOTE 1—(1) Dimension to suit particular head design.  
 (2) Inside diameter shall be sized to allow clearance for sensor sheath, spring stop, and spring.  
 (3) Minimum wall thickness shall be 0.109 in..

FIG. S2.0 Connection Head Extension

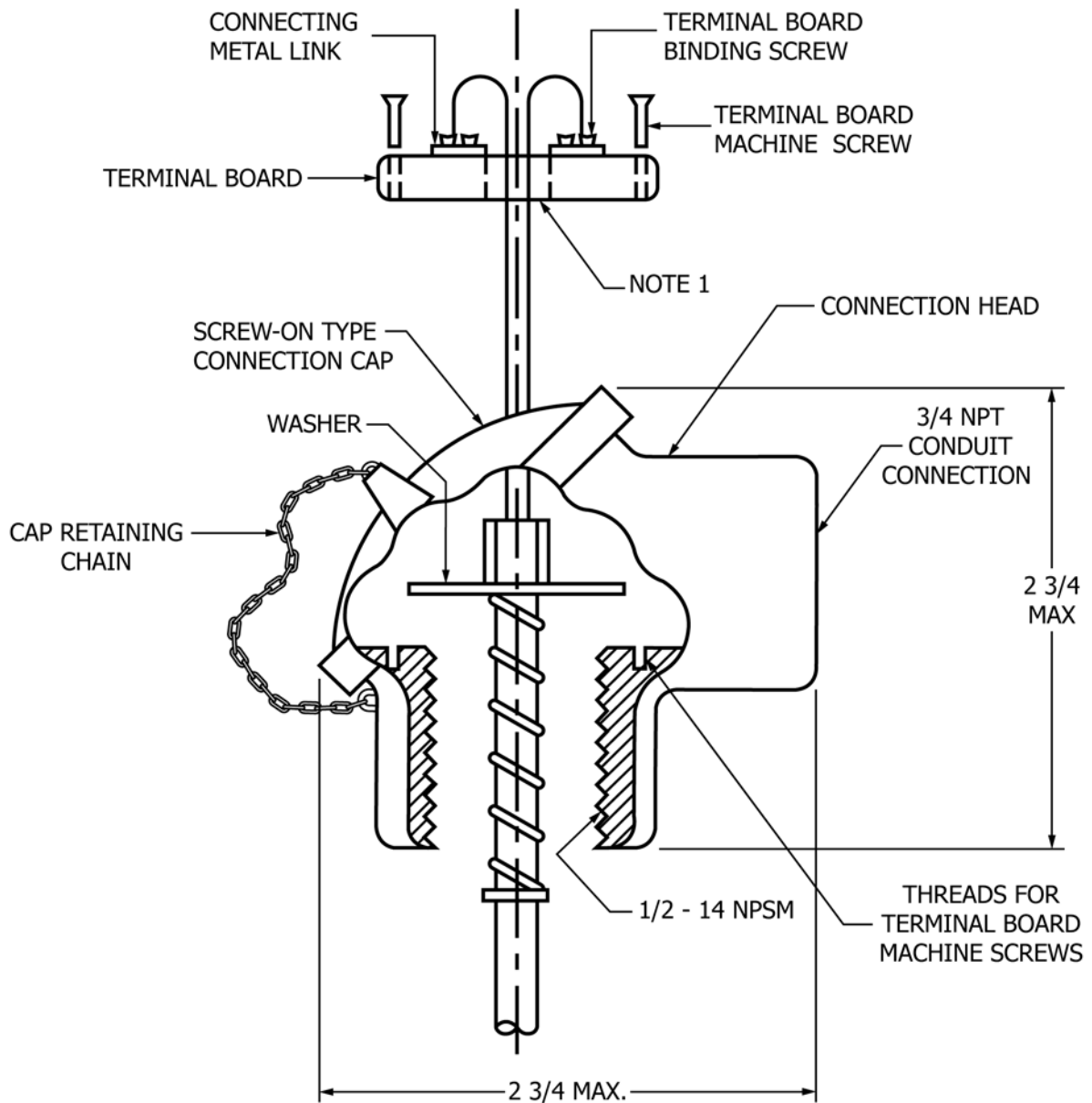

- NOTE 1—Dimensions and tolerances are reference only to meet installation requirements.

FIG. S3.0 Connection Head Construction

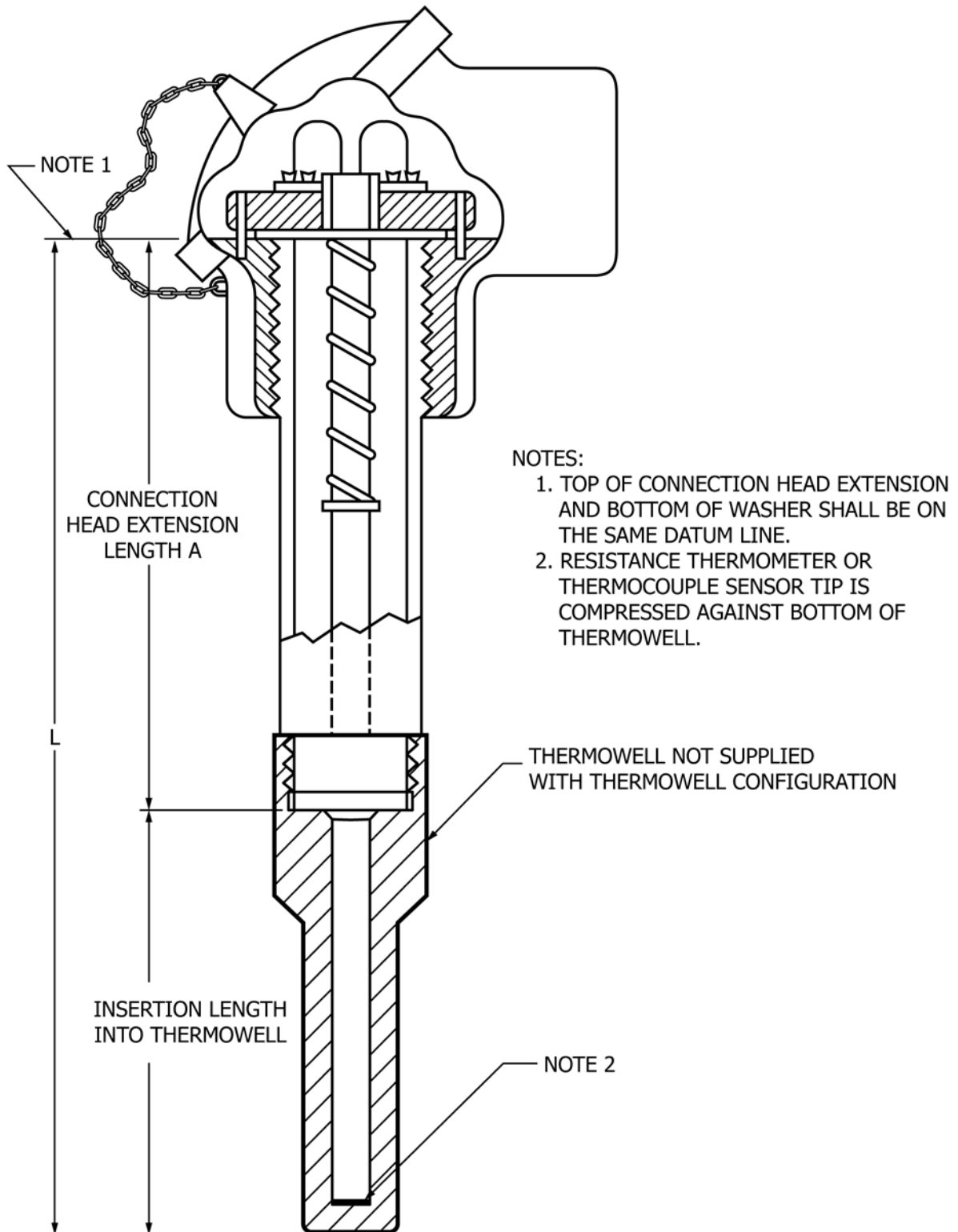

FIG. S4.0 Thermowell Type Resistance Thermometer/Thermocouple



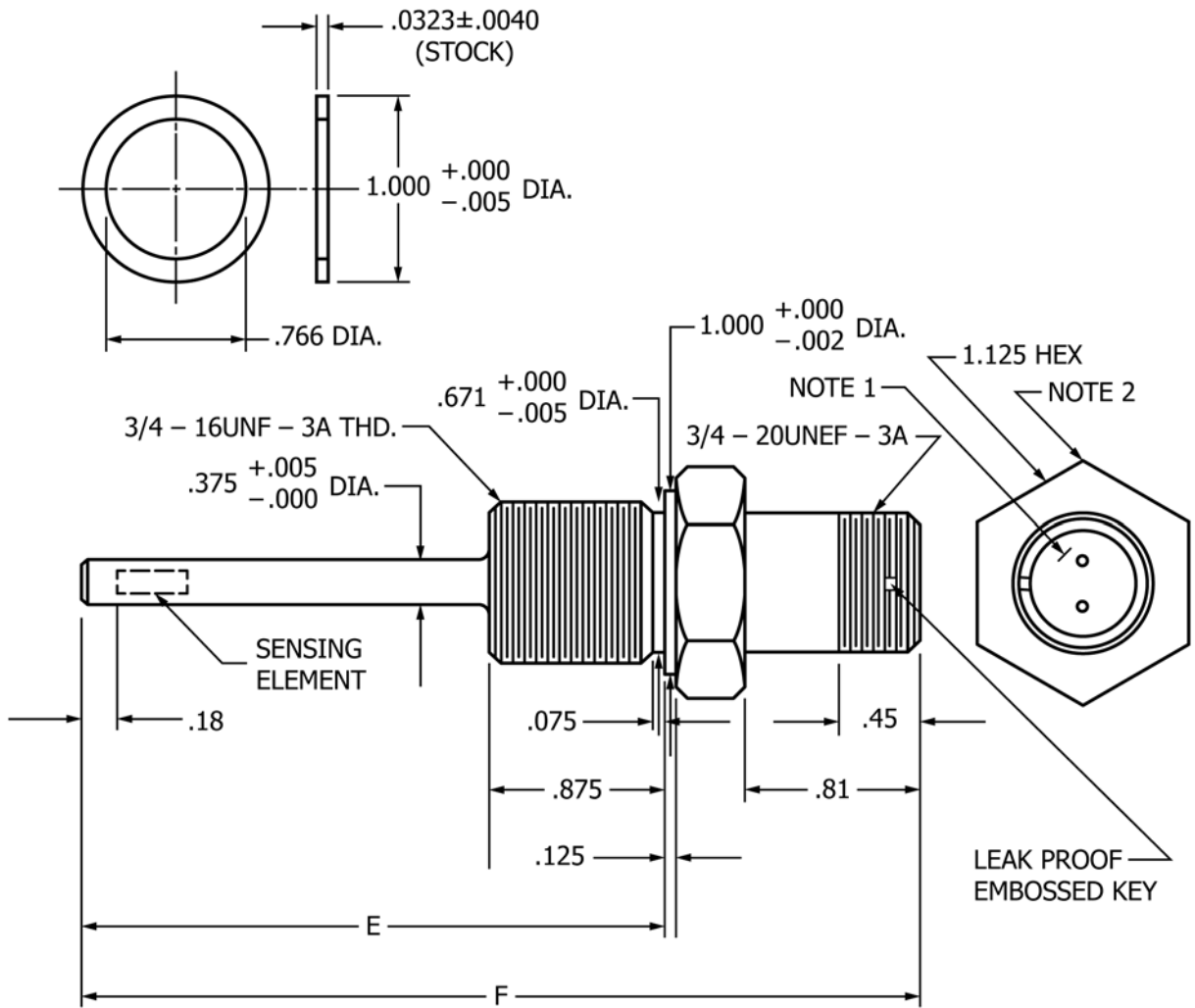

FIG. S5.0 Bare Bulb Type Resistance Thermometer/Thermocouple

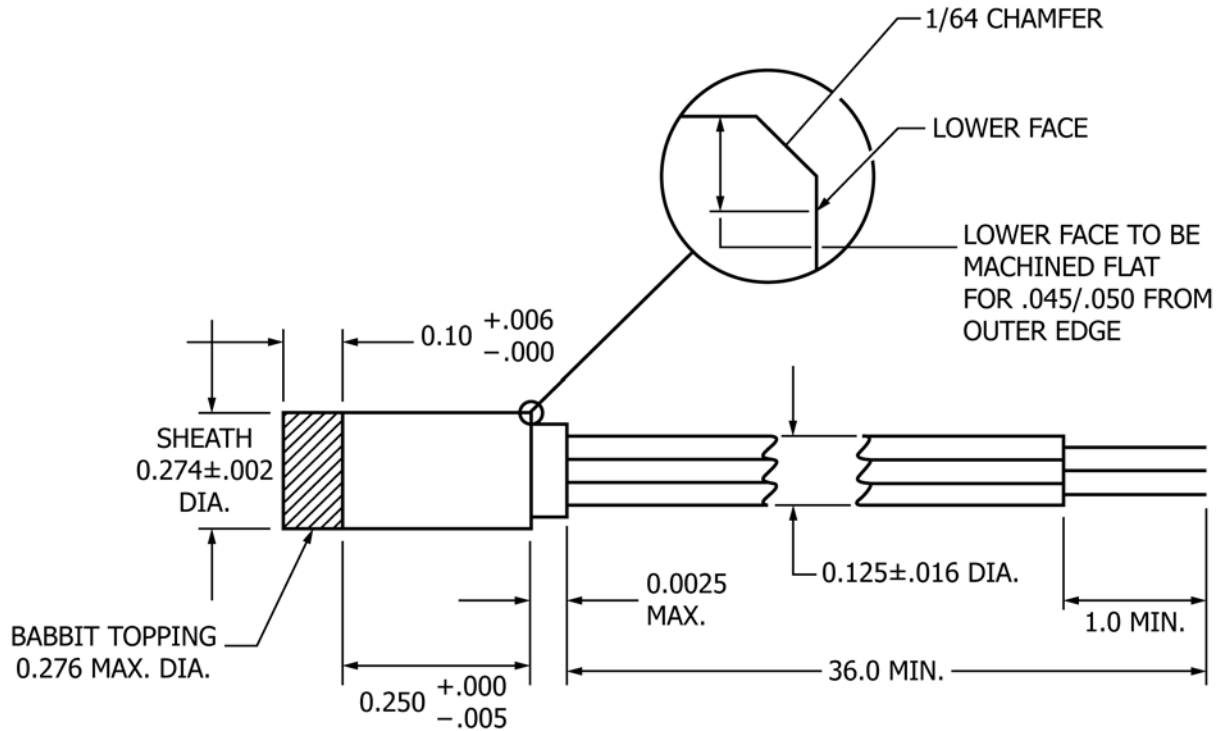

FIG. S6.0 Embedded Type Resistance Thermometer/Thermocouple

TABLE S8 Construction Dimensions and Application Temperatures, Thermowell Configuration

Type	Designation	Insertion Length, cm (in.)	Dimensions, cm (in.) (see Fig. S1.0, Fig. S2.0, and Fig. S4.0)				Temperature Range, °C(°F) <sup>A</sup>	Maximum Connection Head Temp, °C (°F)	Thermowell Design Number (B40.9)
			L ± 1 mm (±0.04)	A ± 0.75 mm (±0.03)	Y <sup>B</sup>	Z <sup>B</sup>			
PRT	4	6.8 (2.69)	11.28 (4.44)	4.45 (1.75)	9.53 (3.75)	13.34 (5.25)	-40 to 316 (-40 to 600)	260 (500)	2(E)
PRT	6	6.8 (2.69)	16.99 (6.69)	10.16 (4.00)	15.24 (6.00)	19.05 (7.50)	-40 to 316 (-40 to 600)	260 (500)	2(E)
PRT	10	11.66 (4.59)	25.88 (10.19)	14.22 (5.60)	24.13 (9.50)	27.94 (11.00)	-40 to 538 (-40 to 1000)	260 (500)	4(E)
PRT	6	11.91 (4.69)	22.07 (8.69)	10.16 (4.00)	20.32 (8.00)	24.13 (9.50)	-40 to 316 (-40 to 600)	260 (500)	4(E)
PRT	8	11.91 (4.69)	22.07 (8.69)	10.16 (4.00)	20.32 (8.00)	24.13 (9.50)	-40 to 316 (-40 to 600)	260 (500)	4(E)
PRT	---	16.99 (6.69)	22.07 (8.69)	5.08 (2.00)	20.32 (8.00)	24.13 (9.50)	-40 to 316 (-40 to 600)	260 (500)	---
NRT	9	6.8 (2.69)	24.61 (9.69)	17.78 (7.00)	22.86 (9.00)	26.67 (10.50)	-40 to 205 (-40 to 400)	149 (300)	2(E)
NRT	10	11.66 (4.59)	25.88 (10.19)	14.22 (5.60)	24.13 (9.50)	27.94 (11.00)	-40 to 205 (-40 to 400)	149 (300)	4(E)
NRT	11	11.91 (4.69)	29.69 (11.69)	17.78 (7.00)	27.94 (11.00)	31.75 (12.50)	-40 to 205 (-40 to 400)	149 (300)	4(E)
KTC	4	6.8 (2.69)	11.28 (4.44)	4.45 (1.75)	9.53 (3.75)	13.34 (5.25)	-40 to 316 (-40 to 600)	260 (500)	2(E)
KTC	6	6.8 (2.69)	16.99 (6.69)	10.16 (4.00)	15.24 (6.00)	19.05 (7.50)	-40 to 316 (-40 to 600)	260 (500)	2(E)
KTC	---	21.26 (8.37)	39.04 (15.37)	17.78 (7.00)	37.29 (14.68)	41.10 (16.18)	-40 to 816 (-40 to 1500)	260 (500)	---
KTC	6	11.91 (4.69)	16.36 (6.44)	4.45 (1.75)	14.61 (5.75)	18.42 (7.25)	-40 to 316 (-40 to 600)	260 (500)	4(E)
KTC	8	11.91 (4.69)	22.07 (8.69)	10.16 (4.00)	20.32 (8.00)	24.13 (9.50)	-40 to 316 (-40 to 600)	260 (500)	4(E)
KTC	---	29.54 (11.63)	47.32 (18.63)	17.78 (7.00)	29.54 (11.63)	49.38 (19.44)	-40 to 816 (-40 to 1500)	260 (500)	---
KTC	---	42.24 (16.63)	46.69 (18.38)	4.45 (1.75)	44.93 (17.69)	48.74 (19.19)	-40 to 316 (-40 to 600)	260 (500)	---
KTC	---	31.45 (12.38)	47.32 (18.63)	15.88 (6.25)	45.57 (17.94)	49.38 (19.44)	-40 to 816 (-40 to 1500)	260 (500)	---

<sup>A</sup> For "A" dimensions less than 12.7 cm (5.0 in.) the temperature range is limited to 56°C (100°F) above the maximum connection head temperature.

<sup>B</sup> Reference dimension only. Y and Z as required to meet installation requirements.

**TABLE S9 Construction Dimensions and Application Temperatures, Bare Bulb Configuration**

Type	Designation	Size, cm (in.) (see Fig. S5.0)		Temperature
		E ± 750 mi (0.03)	F ± 750 mi (0.03)	
NRT	B1	5.71 (2.25)	8.89 (3.50)	-40 to 205
	B2	16.5 (6.50)	19.69 (7.75)	(-40 to 400)
PRT	B3	5.71 (2.25)	8.89 (3.50)	-40 to 538
	B4	16.5 (6.50)	19.69 (7.75)	(-40 to 1000)
KTC	B5	5.71 (2.25)	8.89 (3.50)	-40 to 816
	B6	16.5 (6.50)	19.69 (7.75)	(-40 to 1500)

**TABLE S10 Construction Dimensions and Application Temperatures, Embedded Configuration**

Type	Designation	Temperature Range, °C (°F)
NRT	E1	-40 to 205 (-40 to 400)
PRT	E2	-40 to 205 (-40 to 400)
KTC	E3	-40 to 205 (-40 to 400)

**S38.1.1 Resistance Thermometer**—Resistance thermometers have the following characteristics:

(1) The two resistance thermometer elements have different temperature ranges (excluding the EM configuration):

Nickel: -40 to 205°C (-40 to 400°F),

Platinum: -40 to 538°C (-40 to 1000°F),

(2) High accuracy,

(3) Excellent stability and reproducibility but slow in response,

(4) Easily interchangeable but damages easily if not handled properly. Can be matched to close tolerances for temperature difference measurements, and

(5) Resistance thermometers with platinum elements should be specified for new construction and new instrument installations. Resistance thermometers with nickel elements should be restricted to retrofit and replacements only.

**S38.1.2 Thermocouple Sensors**—Thermocouple sensors have the following characteristics:

(1) Simple construction,

(2) Small signal output is produced which requires sensitive measuring instruments,

(3) Lower cost and faster response than the resistance thermometer,

(4) Type K thermocouple covers a temperature range of -40 to 816°C (-40 to 1500°F) (excluding EM configuration),

(5) Compensation for reference junction temperature is required,

(6) Attains high accuracy but subject to changes within the accuracy limit with use. These changes become more pronounced as the temperature increases,

(7) Preferable for use with thermowells having a 5.08 cm (2 in.) immersion depth since the thermocouple sensor's minimum immersion depth is significantly smaller than that of a resistance thermometer, and

(8) Preferable for use in the EM configuration since extremely fine resistance thermometer element wire is very susceptible to electrical opens, shorts, or intermittent behavior in service.

**S38.2 New Construction**—Resistance thermometers with platinum elements should be specified for new construction and new instrument installations with the following exceptions:

(1) Thermowells have a 5.08 cm (2 in.) immersion depth, see S38.1.2(7), and

(2) EM configuration installations, see S38.1.2(8).

**S38.2.1 Resistance Thermometer Element:**

**S38.2.1.1 Location**—The resistance thermometer element shall be located within the bottom 2 in. of sheath for the thermowell and bare bulb configurations. The resistance thermometer element for all configurations shall be located in a manner such that the installation resistance test requirements are met.

**S38.2.1.2 Resistance Thermometer Current**—Resistance thermometers shall withstand a continuous operating current of 6 milliamperes (mA) direct current (dc).

**S38.2.1.3 Temperature versus Resistance**—Relationships for resistance thermometers shall be in accordance with Table S11 and Table S12 with limits of error specified in S39.2.

NOTE 1—Resistance thermometers with nickel elements shall not be used for temperature applications above 400°F.

**S38.2.2 Thermocouple:**

**S38.2.2.1 Location**—The thermocouple measuring junction shall be ungrounded and located within the bottom 6.35 mm (¼ in.) of the sheath for the thermowell and bare bulb configurations. The thermocouple measuring junction shall be ungrounded and located in the middle of the sheath for the embedded configuration.

**S38.2.2.2 Connecting Wires**—The diameter of the connecting wire shall be the AWG as specified in Table S7. The connecting wire material shall also be in accordance with Table S7.

**S38.2.3 Resistance Thermometers:**

**S38.2.3.1 External Insulation (TW and EM Configurations)**—The material for the external insulation shall be specified in Table S7.

**S38.2.3.2 Color Code**—The external insulation for the single connecting wire attached to one end of the resistance thermometer element shall be color coded red. The external insulation for the two connecting wires attached to the other end of the resistance thermometer element shall be color coded white or amber.

**S38.2.3.3 Internal Insulation (TW and BB Configurations)**—The resistance thermometer connecting wires shall be insulated from the sheath and from each other by alumina (Al<sub>2</sub>O<sub>3</sub>). The alumina shall be alpha alumina with a minimum content of 99.5 % alumina. Sulfur shall not exceed 50 parts per million (ppm) while carbon shall not exceed 200 ppm.

**S38.2.3.4 Number of Connecting Wires**—The resistance thermometers shall be of three-wire construction except for the bare bulb configuration with a nickel element which shall be of two-wire construction.

**S38.2.4 Thermocouple Sensors:**

**S38.2.4.1 External Insulating (TW and EM Configurations)**—The material for external insulation shall be as specified in Table S7.

**S38.2.4.2 Color Code**—The external insulation for the positive (chomel) connecting wire shall be yellow. The external insulation for the negative (alumel) connecting wire shall be red.

S38.2.4.3 *Internal Insulation (TW and EM Configurations)*—The thermocouple sensor connecting wires shall be insulated from each other, except at the measuring junction, and from the sheath by magnesia (MgO). The magnesia shall be electrically fused with a 96.5 % minimum content of magnesia. The sulfur content shall be less than 50 ppm and the carbon content less than 200 ppm.

S38.2.5 *Thermowell Configuration:*

S38.2.5.1 *Temperature Exposures*—Maximum connecting head temperature shall be 300°F for resistance thermometers with nickel elements, 260°C (500°F) for resistance thermometers with platinum elements, and 260°C (500°F) for type K thermocouple sensors.

S38.2.5.2 *Watertight Enclosure*—Resistance thermometers and thermocouple sensors shall be watertight such that water directed at the sensor from any angle is prevented from entry.

S38.2.5.3 *Construction*—Thermowell configuration shall consist of resistance thermometer or thermocouple sensor, construction head, and a connection head extension as shown of Figs. S1.0-S4.0.

S38.2.5.4 *Connection Head Cap*—The connection head of the thermowell configuration shall be provided with a screw-on type cap with metal link chain.

S38.2.5.5 *Terminal Board*—Terminal board shall be secured to the connection head.

S38.2.5.6 *Thermowells*—When resistance thermometers and thermocouple sensors are intended for use with thermowells, the thermowells shall be in accordance with ASME B40.9, Supplement 1.

S38.2.6 *Bare Bulb Configuration:*

S38.2.6.1 *Temperature Exposures*—The maximum connector receptacle and plug temperature shall be 149°C (300°F).

S38.2.6.2 *Watertight Enclosure*—Resistance thermometers and thermocouple sensors shall be watertight such that water directed at the sensor from any angle is prevented from entry.

S38.2.6.3 *Construction*—The bare bulb configuration shall be of one-piece construction as shown on Fig. S5.0.

S38.2.6.4 *End Cap*—The connector receptacle shall be provided with a screw-on end cap.

S38.2.6.5 *Pressure Requirements*—The resistance thermometer and thermocouple sensor shall withstand 37.9 MPa (5500 psi) when inserted into air stream at a temperature of 182°C (360°F) with velocity of 12.2 m (40 ft) per second.

S38.2.7 *Embedded Configuration:*

S38.2.7.1 *Temperature Exposures*—Resistance thermometers and thermocouple sensors shall withstand a maximum temperature of 205°C (400°F) for continuous use, 274°C (525°F) for short term exposure of 15 min, and 288°C (550°F) for short term exposure of 2 min.

S38.2.7.2 *Construction*—The embedded configuration shall consist of the resistance thermometer or thermocouple sensor as shown in Fig. S6.0.

S38.2.7.3 *Scoring*—The material and construction of the resistance thermometer or thermocouple sensor shall be such that in the event the bearing should fail and be wiped to a depth of  $2.54 \pm 254 \mu\text{m}$  ( $0.10 \pm 0.01 \text{ in.}$ ) over the area of the resistance thermometer or thermocouple sensor, scoring of a carbon steel shaft having a Brinell hardness of 170 to 180 will be limited to a depth of  $7.62 \mu\text{m}$  (300  $\mu\text{in.}$ ) or less.

S38.2.7.4 *Babbitt Topping*—The tip of the sheath shall contain a  $2.54 \pm 1.5 \text{ mm}$  ( $0.10 \pm 0.06 \text{ in.}$ ) thick topping of babbitt. The diameter, including maximum to tolerance, of the babbitt topping shall conform to the diameter of the sheath.

S38.2.8 *Cleaning and Surface Finishes*—Surface of castings, forgings, molded parts, stampings, machined and welded parts shall be free of defects such as cracks, porosity, undercuts, voids, and gaps as well as sand, dirt, fins, sharp edges, scale, flux, and other harmful or extraneous materials. External surface shall be smooth and edges shall be either rounded or beveled. There shall be no burn-through. There shall be no warpage or dimensional change due to heat from welding operation. There shall be no damage to adjacent parts resulting from the welding.

**TABLE S11 Temperature versus Resistance Characteristics for Resistance Thermometers with Nickel Elements**

Temperature °C (°F)	Resistance (Ohms)	Temperature °C (°F)	Resistance (Ohms)	Temperature °C (°F)	Resistance (Ohms)	Temperature °C (°F)	Resistance (Ohms)
-40.0 (-40)	92.75	21.1 (70)	135.46	87.8 (190)	189.81	154.4 (310)	253.69
-34.4 (-30)	96.39	26.7 (80)	139.66	93.3 (200)	194.75	160.0 (320)	259.48
-28.9 (-20)	100.07	32.2 (90)	143.92	98.9 (210)	199.75	165.6 (330)	265.36
-23.3 (-10)	103.80	37.8 (100)	148.24	104.4 (220)	204.83	171.1 (340)	271.32
-17.8 (0)	107.57	43.3 (110)	152.61	110.0 (230)	209.97	176.7 (350)	277.35
-12.2 (10)	111.40	48.9 (120)	157.04	115.6 (240)	215.18	182.2 (360)	283.46
-6.7 (20)	115.28	54.4 (130)	161.54	121.1 (250)	220.46	187.8 (370)	289.66
-1.1 (30)	119.21	60.0 (140)	166.09	126.7 (260)	225.82	193.3 (380)	295.93
0.0 (32)	120.00	65.6 (150)	170.71	132.2 (270)	231.24	198.9 (390)	302.29
4.4 (40)	123.19	71.1 (160)	175.39	137.8 (280)	236.74	204.4 (400)	308.73
10.0 (50)	127.23	76.7 (170)	180.13	143.3 (290)	242.32		
15.6 (60)	131.32	82.2 (180)	184.94	148.8 (300)	247.96		



**TABLE S12 Temperature versus Resistance Characteristics for Resistance Thermometers with Platinum Elements**

Temperature °C (°F)	Resistance (Ohms)	Temperature °C (°F)	Resistance (Ohms)	Temperature °C (°F)	Resistance (Ohms)	Temperature °C (°F)	Resistance (Ohms)
-40.0 (-40)	83.97	100.0 (212)	139.24	260.0 (500)	199.58	415.6 (780)	255.35
-28.9 (-20)	88.44	104.4 (220)	140.96	271.1 (520)	203.66	426.7 (800)	259.23
-17.8 (0)	92.90	126.7 (260)	149.51	282.2 (540)	207.72	437.8 (820)	263.09
-6.7 (20)	97.34	137.8 (280)	153.76	293.3 (560)	211.77	448.9 (840)	266.93
0.0 (32)	100.00	148.8 (300)	158.00	304.4 (580)	215.81	460.0 (860)	270.77
4.4 (40)	101.77	160.0 (320)	162.22	315.6 (600)	219.83	471.1 (880)	274.58
15.6 (60)	106.18	171.1 (340)	166.43	326.7 (620)	223.83	482.2 (900)	278.39
27.6 (80)	110.58	182.2 (360)	170.63	337.8 (640)	227.82	493.3 (920)	282.17
37.8 (100)	114.96	193.3 (380)	174.81	348.9 (660)	231.80	504.4 (940)	285.95
48.9 (120)	119.33	204.4 (400)	178.97	360.0 (680)	235.76	515.6 (960)	289.71
60.0 (140)	123.69	215.6 (420)	183.12	371.1 (700)	239.71	526.7 (980)	293.45
71.1 (160)	128.03	226.7 (440)	187.26	382.2 (720)	243.64	537.8 (1000)	297.18
82.2 (180)	132.35	237.8 (460)	191.38	393.3 (740)	247.56		
93.3 (200)	136.67	248.9 (480)	195.49	404.4 (760)	251.46		

### S39. Performance Requirements

S39.1 *Insulation Resistance*—The insulation resistance shall be determined at 50 VDC and shall be no less than 10 megohms.

S39.2 *Accuracy*—The span and limits of error shall be as specified in Table S13 (see S42.2).

**TABLE S13 Accuracy (Span of Limits of Error)**

Temperature Range, °C (°F)	Limits of Error
Resistance Thermometers with Nickel Elements	
-40 to 93 (-40 to 200)	±1.1°C (2°F)
93 to 205 (200 to 400)	±1 % of temperature measured
Resistance Thermometers with Platinum Elements	
-40 to 277 (-40 to 530)	±1.1°C (2°F)
277 to 538 (530 to 1000)	±3/8 % of temperature measured
Thermocouple Sensors	
-40 to 277 (-40 to 530)	±1.1°C (2°F)
277 to 816 (530 to 1500)	±3/8 % of temperature measured

S39.2.1 *Accuracy Repeatability*—The span and limits of error shall be as specified in Table S14.

**TABLE S14 Accuracy Repeatability (Span of Limits of Error)**

Temperature Range, °C (°F)	Limits of Error
Resistance Thermometers with Nickel Elements	
-40 to 93 (-40 to 200)	±0.6°C (1°F)
93 to 205 (200 to 400)	±0.5 % of temperature measured
Resistance Thermometers with Platinum Elements	
-40 to 277 (-40 to 530)	±0.6°C (1°F)
277 to 538 (530 to 1000)	±3/16 % of temperature measured
Thermocouple Sensors	
-40 to 277 (-40 to 530)	±0.6°C (1°F)
277 to 816 (530 to 1500)	±3/16 % of temperature measured

S39.2.2 *Reference Measurement*—The performance shall conform to S39.2 (see S42.2.2).

S39.3 *Response Time*—Response time of the resistance thermometers and thermocouple sensors shall be as follows:

- (1) 8 s or less for thermowell configuration,
- (2) 15 s or less for bare bulb configuration, and
- (3) 5 s or less for embedded configuration.

S39.4 *Self-heating (Resistance Thermometers only)*—The temperature change due to self heating of the resistance thermometers shall not exceed 0.6°C (1°F) at an input power level of 5 milliwatts (see S42.4).

S39.5 *Thermal Cycling*—When subjected to 1500 thermal cycles, there shall be no shorts, opens, or evidence of intermittent behavior. The resistance thermometers and the thermocouple sensors shall show no evidence of physical damage as result of thermal cycling. The reference measurement performed at the conclusion of the thermal cycling shall conform to S39.2.

S39.6 *Over-temperature (EM Configuration)*—Resistance thermometers and thermocouple sensors shall conform to the temperature span and accuracy requirements specified in S39.2 after being subjected to over-temperature. During over-temperature, there shall be no shorts, opens, or evidence of intermittent behavior. The reference measurement performed at the conclusion of over-temperature shall conform to S39.2 (see S42.5).

S39.7 *Terminal Strength (TW and EM Configurations)*—Attachment of connecting wires to the connecting wire end closure and their encapsulation into the sheath shall withstand the specified static load. The resistance thermometers and thermocouple sensors shall be axially loaded for 15 min without causing circuit failure or loss of watertight integrity (see S42.7). The reference measurement performed at the conclusion of static loading shall conform to S39.2.

S39.8 *Connecting Wire end Closure*—When subjected to a vacuum or pressure, there shall be no physical damage to the resistance thermometers and thermocouple sensors and there shall be no observed evidence of air bubbles while under vacuum. After application of vacuum and pressure, the performance of the resistance thermometers and thermocouple sensors shall conform to S39.1 and S39.2 (see S42.8).

S39.9 *Enclosure (TW and BB configurations)*—There shall be no leakage of water into the watertight enclosure (see S42.9).

S39.10 *Salt Spray*—Resistance thermometers and thermocouple sensors shall show no appreciable corrosion or other damage when subjected to salt spray (S42.10). The performance of the resistance thermometers and thermocouple sensors shall conform to S39.1 and S39.2.

S39.11 *Spring Loading (TW Configuration)*—When compressed 7.62 cm (3/16 in.), the spring shall exert a minimum force of 2.27 kg (5 lb) (S42.11).

S39.12 *Vibration*—When exposed to vibration per MIL-STD-167-1, the resistance thermometers and thermocouple sensors shall show no evidence of improper operation, failure, or damage (see S42.12). The electrical signal from the resistance thermometer and thermocouple sensor shall be monitored during vibration and there shall be no shift in the temperature indication. A reference measurement performed at the conclusion of vibration shall meet the specified accuracy requirements of S39.2.

S39.13 *Shock*—Resistance thermometers and thermocouple sensors shall withstand the effects of shock in accordance with MIL-S-901 (S42.13). A reference measurement performed after exposure to shock shall meet the specified accuracy requirements of S39.2.

S39.14 *Pressure (EM Configuration)*—The embedded resistance thermometers and thermocouple sensors shall not deform to such a degree that the babbitt surface is visually determined to be dimpled, cracked, or ruptured after exposure to a pressure of 12.4 MPa (1800 lb/in.<sup>2</sup>) gauge. The insulation resistance between each connecting wire and the babbitt surface shall be no less than 10 megohms when measured both before and at the conclusion of exposure to pressure. The resistance thermometers and thermocouple sensors shall meet the reference measurement requirements of S39.2 both before and at the conclusion of exposure to pressure (S42.14).

S39.15 *Scoring (EM Configuration)*—The stylus traces resulting from the application of a scoring force of 3.63 kg (8 lb) shall not indicate a scoring depth exceeding 7.62 micrometers (300 microinches) (S42.15).

#### S40. Workmanship, Finish, and Appearance

S40.1 *Cleaning and Surface Finishes*—Surfaces of castings, forgings, molded parts, stampings, machined and welded parts shall be free of defects such as cracks, porosity, undercuts, voids and gaps as well as sand, dirt, fins, sharp edges, scale, flux, and other harmful or extraneous materials. External surfaces shall be smooth and edges shall be either rounded or beveled. There shall be no burn-through. There shall be no warpage or dimensional change due to heat from welding operation. There shall be no damage to adjacent parts resulting from welding.

#### S41. Number of Tests and Retests

S41.1 The number of tests and retests, if any, shall be specified in the acquisition requirements.

#### S42. Test Methods

S42.1 *Insulation Resistance*—Insulation resistance shall be determined by applying 50 V (dc) between the connecting wires and the sheath. Performance shall conform to S39.1.

S42.2 *Accuracy*—Resistance thermometers and thermocouple sensors shall be calibrated in accordance with the requirements of S39.2. The temperature of the bath fluid shall be as shown in Table S15,  $\pm 2.8^{\circ}\text{C}$  ( $5^{\circ}\text{F}$ ), with a temperature gradient of  $\pm 0.06^{\circ}\text{C}$  ( $1/10^{\circ}\text{F}$ ),  $0.28^{\circ}\text{C}$  ( $1/2^{\circ}\text{F}$ ) for salt bath, under steady state temperature conditions. The resistance thermometers and thermocouple sensors shall be calibrated at temperatures listed in the increasing order. Performance shall conform to S39.2.

**TABLE S15 Calibration Temperatures**

Configuration	Type	Temperature Range, (°F)	Calibration Values, (°F)
TW, BB	NRT	-40 to 205 (-40 to 400)	-29, 0, 27, 82, 138, 193 (-20, 32 <sup>A</sup> , 80, 180 <sup>A</sup> , 280, 380 <sup>A</sup> )
	PRT	-40 to 538 (-40 to 1000)	-29, 0, 93, 205, 316, 427, 527 (-20, 32 <sup>A</sup> , 200 <sup>A</sup> , 400, 600 <sup>A</sup> , 800, 980 <sup>A</sup> )
	KTC	-40 to 816 (-40 to 1500)	-29, 0, 93, 205, 316, 482, 649 (-20, 32 <sup>A</sup> , 200, 400, 600 <sup>A</sup> , 900, 1200 <sup>A</sup> )
EM	NRT	-40 to 205 (-40 to 400)	-29, 0, 27, 82, 138, 193 (-20, 32 <sup>A</sup> , 80, 180 <sup>A</sup> , 280, 380 <sup>A</sup> )
	PRT	-40 to 538 (-40 to 1000)	-29, 0, 93, 205, 316, 427, 527 (-20, 32 <sup>A</sup> , 200 <sup>A</sup> , 400, 600 <sup>A</sup> , 800, 980 <sup>A</sup> )
	KTC	-40 to 816 (-40 to 1500)	-29, 0, 93, 205, 316, 482, 649 (-20, 32 <sup>A</sup> , 200, 400, 600 <sup>A</sup> , 900, 1200 <sup>A</sup> )

<sup>A</sup> These values shall be used for reference measurement (see S42.2.2).

S42.2.1 *Accuracy Repeatability*—The accuracy test specified in S42.2 shall be performed two additional times. Performance shall conform to S39.2.1.

S42.2.2 *Reference Measurement*—The accuracy test as specified in S42.2 shall be referred to as a “reference measurement” when performed at the conclusion of another test listed in Table S15. The reference measurement shall only be conducted at the temperatures that are specified for a reference measurement in Table S15. Performance shall conform to S39.2.2.

S42.3 *Response Time*—Resistance thermometers and thermocouple sensors shall be tested in accordance with the conditions of Table S16. The low or high temperature test shall be used depending upon the configuration and the type of resistance thermometer or thermocouple sensor criteria in Table S17. The time it takes the standard cylinder output to rise from an equivalent temperature from  $T_1$  to  $T_2$  in Table S16 shall be the standard cylinder response time. The standard cylinder response time shall be within the values listed in Table S16 for at least six consecutive trials not counting those performed in establishing the proper temperature bath conditions (temperature, orientation, stirrer speed, and so forth). The response time of the resistance thermometers and thermocouple sensors shall be the average of at least six readings taken during at least six consecutive trials where the standard cylinder was within the values specified in Table S16. The test conditions of the resistance thermometers and thermocouple sensors are also those contained in Table S17. Performance shall conform to S39.3.

TABLE S16 Response Time Test Conditions

Test Conditions	Low Temperature Test	High Temperature Test
Maximum temperature °C (°F)	205 (400)	538, 816 (1000, 1500)
Bath medium	Water	Salt
Bath temperature °C (°F)	82 (180)	505 (940)
Initial temperature °C (°F)	10 (50)	238 (460)
(Start timing) temperature T <sub>1</sub> °C (°F)	27 (80)	305 (580)
(Stop timing) temperature T <sub>2</sub> °C (°F)	62 (143.2)	431 (808)
Standard cylinder response time (s)	6.0 ± 0.2	8.0 ± 0.2

TABLE S17 Conditions for Temperature

Configuration	Type	Temperature Test
TW	NRT	Low
BB	PRT, KTC	High
	NRT	Low
	PRT, KTC	High
EM	NRT, PRT, KTC	Low

S42.3.1 *Standard Cylinder*—A standard cylinder shall be used for this test. The information needed to construct a standard cylinder is provided on Fig. S7.0. Connecting wires from the standard cylinder thermocouple shall terminate at an ice bottle, ice point reference junction or a reference junction compensated electronic indicator. If an ice bottle or ice point reference junction is used, the extension wires coming from the reference junction shall be connected to an indicator such as a potentiometer or a millivolt recorder. No matter what form of indicator is used, the indicator shall have a response time not less than two times faster than the response time of the temperature rise that the standard cylinder will measure (see Table). Response time measurement shall be conducted using either a stop watch or any method capable of timing to 0.2 s or better.

S42.3.2 *Temperature Bath*—Two temperature baths are used in performing this test. The baths shall be sufficiently large or constructed in such a manner that the temperature bath fluid will not be cooled by greater than 0.5 % of the span when either the cylinder or the filled system thermometer is immersed. The “hot” bath shall contain a variable speed stirrer. Two liquid temperature bath fluids and temperatures are permissible for use with this test and are specified in Table S16. One fluid temperature is referred to as the “cold bath temperature” while the other is referred to as the “hot bath temperature.”

S42.3.3 *Set Up*—The conditions in the hot temperature bath fluid shall be set up such that the standard cylinder response time will be within the limits specified in S39.3. Hot temperature bath fluid conditions and, thus, the standard cylinder response time, will be changed by varying the stirring parameters. The standard cylinder shall be immersed in the temperature bath fluid to the bottom of the standard cylinder collar (see Fig. S7.0 for location). The standard cylinder shall always be immersed in the hot temperature bath fluid in the same location and in the same orientation. The immersion depth of the standard cylinder thermocouple measuring junction and the immersion depth of the embedded configuration resistance thermometer or thermocouple sensor shall be maintained at the same level.

S42.3.4 *Determining Response Time*—The resistance thermometer or thermocouple sensor (or standard cylinder) shall be immersed in the hot temperature bath until there is no further indication of temperature rise. The resistance thermometer or thermocouple sensor (or standard cylinder) shall then be immersed in the cold temperature bath until there is no further indication of temperature decrease. The resistance thermometer or thermocouple sensor (or standard cylinder) shall again be immersed in the hot temperature bath. Timing shall be started when the resistance thermometer or thermocouple (or standard cylinder) indicator reaches temperature T<sub>1</sub> (see Table S16) and stopped when temperature T<sub>2</sub> is reached. The time it takes the resistance thermometer or thermocouple (or standard cylinder) to indicate the difference between temperatures T<sub>1</sub> and T<sub>2</sub> shall be defined as the response time.

S42.3.5 *Conducting Response Time Test*—The response time test shall be conducted by taking alternate response time measurements between the standard cylinder and the thermometer. Each alternation of the standard cylinder’s then the thermometer’s response time measurements shall be defined as a trial.

S42.4 *Self-heating (Resistance Thermometers)*—The self-heating test shall be conducted in a water bath under the conditions specified in S42.2. A resistance thermometer shall be immersed in the water bath to at least the minimum immersion depth and allowed to stabilize at 82°C (180°F). A series of direct currents shall be passed through the resistance thermometer elements and maintained until steady state is attained such that the power impact is successively 0.5, 1.0, 3.0, and 5.0 milliwatts. A curve of the indicated temperature versus power input shall be plotted and extrapolated to zero power input. The difference between the indicated temperature at 5 milliwatts input and the extrapolated value at the indicated temperature at zero power input is the effect due to self heating. Performance shall conform to S39.4.

S42.5 *Thermal Cycling*—Resistance thermometers and thermocouple sensors shall be heated and cooled for 1500 cycles in accordance with Table S18. Cycle rate shall not exceed two cycles per minute. The output of the resistance thermometers and thermocouple sensors shall be monitored during thermal cycling. Connection head temperature shall not exceed the maximum connection head temperature specified in Table S7. Prior to and following the test, a reference measurement as specified in S42.2.2 shall be conducted. Performance shall conform to S39.5.

TABLE S18 Thermal Cycling Conditions

Temperature Range, °C (°F)	Cycle Temperature, °C (°F) ±10 %	
	Lower	Upper
-51 to 205 (-60 to 400)	182 (360)	205 (400)
-40 to 538 (-40 to 1000)	38 (100)	482 (900)
-40 to 816 (-40 to 1500)	93 (200)	649 (1200)

S42.6 *Over-temperature (EM Configuration)*—Resistance thermometers and thermocouple sensors, while at ambient temperature, shall be quickly (within 2 s) immersed for a period of 15 ± 0.5 min in a temperature bath in which the fluid is stabilized to a temperature of 274 ± 2.8°C (525 ± 5°F). The resistance thermometer or thermocouple sensor immersion depth shall be 7.62 cm (3/16 in.) if not installed in a fixture. If the resistance thermometer or thermocouple sensor is installed

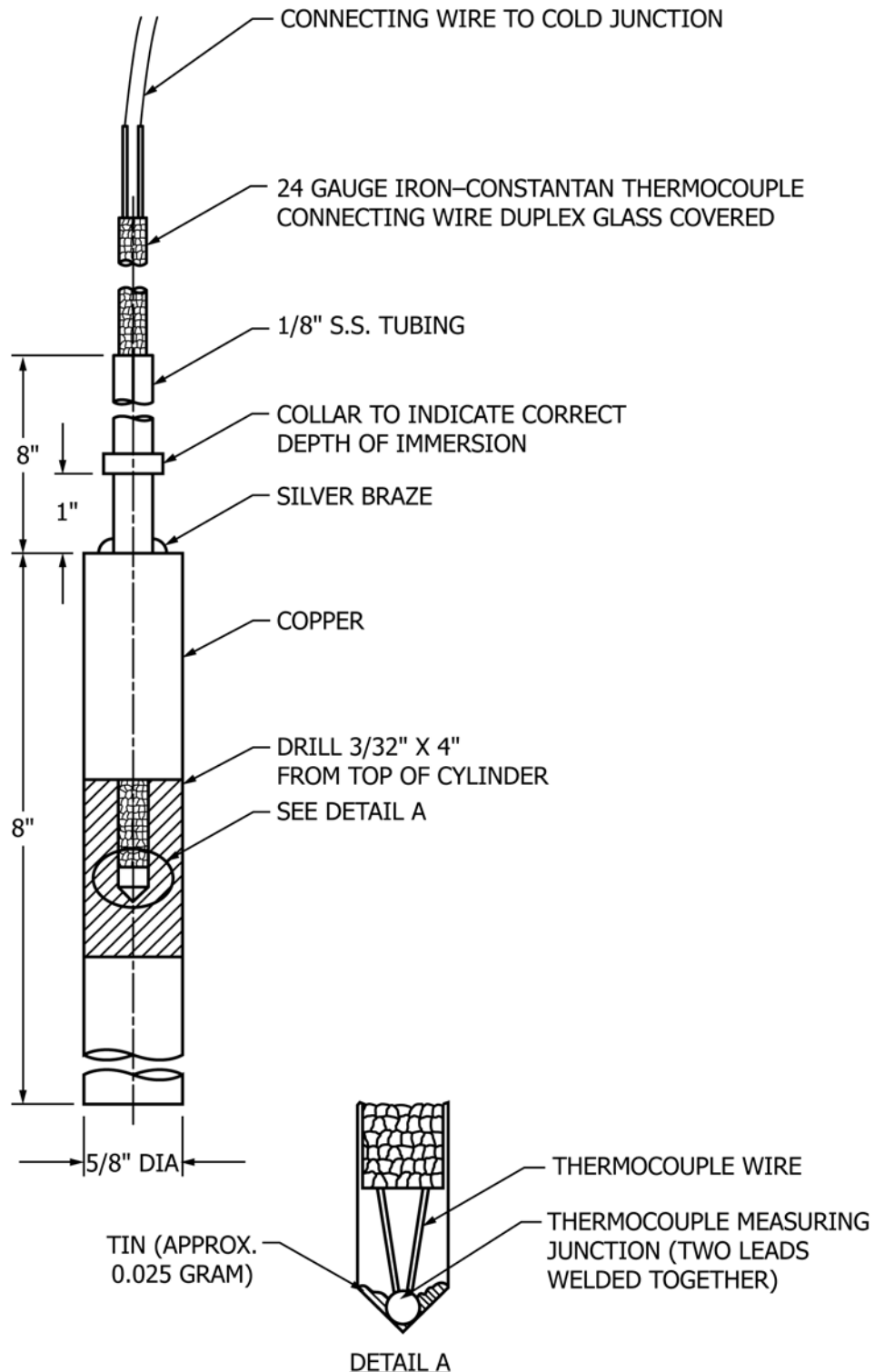

FIG. S7.0 Standard Cylinder

in a fixture, it shall be immersed to a sufficient depth to provide an accurate bath temperature measurement. The resistance thermometers or thermocouple sensors shall then be quickly immersed in another temperature bath containing the same fluid stabilized at a temperature of  $288 \pm 2.8^{\circ}\text{C}$  ( $550 \pm 5^{\circ}\text{F}$ ) to the specified depth for a period of  $2 \pm 0.05$  min. The

resistance thermometers or thermocouple sensors shall then be quickly immersed in the first temperature bath in which the fluid is stabilized at a temperature of  $274 \pm 2.8^{\circ}\text{C}$  ( $525 \pm 5^{\circ}\text{F}$ ) to the specified depth for a period of  $15 \pm 0.5$  min. The output of the resistance thermometers or thermocouple sensors shall be monitored during this test. The resistance thermometers or



thermocouple sensors shall reach the bath fluid temperature within 1 min after immersion into a temperature bath whether or not a test fixture is used. A reference measurement shall be performed at the conclusion of this test. Performance shall conform to S39.6.

**S42.7 Terminal Strength (TW and EM Configurations)**—With the resistance thermometers and thermocouple sensors firmly held in a holding fixture, a static tensile load of 2.27 kg (5 lb) shall be applied to each connecting wire simultaneously for 15 min for the thermowell configuration. For the embedded configuration, a static tensile load of 2.27 kg (5 lb) shall be applied to each connecting wire separately. The direction of the load shall be along the longitudinal axis of the resistance thermometers and thermocouple sensors. A reference measurement shall be performed at the conclusion of this test. The performance shall conform to S39.7.

**S42.8 Connecting Wire End Closure**—During this test, the resistance thermometers and thermocouple sensors of the thermowell configuration shall be removed from the connection head. No end cap shall be threaded over the connector receptacle of the resistance thermometers and thermocouple sensors of the bare bulb configuration. Connecting wire end closure shall meet the requirements specified in S39.8.

**S42.8.1 Vacuum Portion**—The desiccator shall be half filled with water and evacuated of dissolved air. The resistance thermometers and thermocouple sensors shall be immersed in this desiccator. The desiccator shall then be subjected to an absolute pressure of  $27.5 \text{ kPa} \pm 3.5 \text{ kPa}$  ( $4.0 \pm 0.5 \text{ lb/in.}^2$ ) for 15 min. The connecting wire end closure shall be observed for evidence of air leaks.

**S42.8.2 Pressure Portion**—The resistance thermometers and thermocouple sensors shall be placed inside a pressure chamber and the pressure chamber shall be hydrostatically pressurized with water to  $172.4 \pm 3.5 \text{ kPa}$  ( $25 \pm 5 \text{ lb/in.}^2$ ) for a period of no less than  $15 \pm 0.5 \text{ min}$ .

**S42.8.3 Post Test Measurements**—At the conclusion of this test, an insulation resistance test followed by a reference measurement shall be performed. Performance shall conform to S39.8.

**S42.9 Enclosures (TW and BB Configurations)**—The resistance thermometers and thermocouple sensors of the thermowell configuration shall be tested with the thermowell attached to the connection head extension and a threaded plug inserted into the connection head conduit connection. The resistance thermometers and thermocouple sensors of the bare bulb configuration shall be tested with an end cap threaded over the connector receptacle. The test shall consist of a solid stream of water from a 2.54 cm (1 in.) diameter nozzle at a rate of 246 L (65 gal) per minute. The stream shall be directed on all surfaces of the equipment and its mounting surface from a maximum distance of 3.048 m (10 ft) and for a minimum of 60 min.

**S42.10 Salt Spray**—Resistance thermometers and thermocouple sensors shall be subjected to the salt spray test in accordance with ASTM B117. The salt spray test shall run for a duration of 96 h. The salt solution shall be  $5 \pm 1 \%$  concentration (5 parts by weight of salt in 95 parts by weight of water). At the conclusion of this test, an insulation resistance

test followed by a reference measurement shall be performed. Performance shall conform to S39.10.

**S42.10.1 Thermowell Configuration**—The resistance thermometer or thermocouple sensor shall be removed from the connection head when the test has reached the 48 h point. A plug shall be threaded into the connection head conduit connection (see Fig. S3.0) and a thermowell shall be threaded onto the connection head extension. The connection head (including connection head extension, plug, and thermowell) and the resistance thermometer or thermocouple sensor shall be separately subjected to the salt spray test.

**S42.10.2 Bare Bulb Configuration**—The resistance thermometers and thermocouple sensors shall be subjected to the salt spray test without an end cap threaded over the connector receptacle.

**S42.11 Spring Loading (TW Configuration)**—Resistance thermometers and thermocouple sensors shall be mounted in a jig and compressed 7.62 cm ( $\frac{3}{16}$  in.) three successive times. The compressive force of the spring shall be measured. Performance shall conform to S39.11.

**S42.12 Vibration**—The vibration test shall be in accordance with MIL-STD-167-1 except as modified herein and shall consist of the exploratory test, the variable frequency test, and the endurance test. These tests shall be conducted in the sequence listed and shall meet the requirements specified in S39.12. Each of the three tests shall be conducted in each of the three mutually perpendicular axes. All three tests shall be completed in one axis before performing the tests in the other axis. The resistance thermometers and thermocouple sensors shall be secured to the fixture in the surface mounted configuration.

**S42.12.1 Exploratory Test:**

(1) Maintain each discrete frequency from 5 to 100 Hz at 1 Hz intervals for a minimum of 15 s, or a sweep rate that shall not exceed 4 Hz per minute.

(2) Displacement or acceleration shall be as specified in Table S19.

**TABLE S19 Vibration Displacement Criteria**

Frequency Range, (Hz) (incl)	Table Displacement Exploratory Test, $\mu\text{m}$ (in.)	Variable Frequency Test, $\mu\text{m}$ (in.) Peak to Peak
5 to 20	$508 \pm 100$ ( $0.020 \pm 0.004$ )	$1524 \pm 300$ ( $0.060 \pm 0.012$ )
21 to 50	$254 \pm 50$ ( $0.010 \pm 0.002$ )	$1016 \pm 200$ ( $0.040 \pm 0.008$ )
51 to 100	$127 \pm 25$ ( $0.005 \pm 0.001$ )	$508 \pm 100$ ( $0.020 \pm 0.004$ )

(3) Frequencies and locations where resonance occurs during this test shall be noted.

**S42.12.2 Variable Frequency Test:**

(1) Discrete frequency interval of 1 Hz.

(2) Frequency range 5 to 100 Hz.

(3) Each discrete frequency shall be maintained for a minimum of 5 min.

(4) Displacements shall be as specified in Table S19.

(5) Frequencies and locations where resonance occurs during this test shall be noted.

**S42.12.3 Endurance Test:**

(1) The resistance thermometers and thermocouple sensors shall be subjected to a 2-h endurance run at each resonance.

(2) Displacement or acceleration shall be the variable frequency test values specified in Table S19.

(3) If no resonance is found, a 2-h performance run shall be performed at 100 Hz. A reference measurement shall be performed after the conclusion of the vibration test. Performance shall conform to S39.12.

**S42.13 Shock**—Shock tests shall be in accordance with MIL-S-901 grade A, class I, type C for lightweight equipment. Resistance thermometers and thermocouple sensors shall be mounted to simulate actual installation. Resistance thermometers and thermocouple sensors shall be mounted no less than 7.62 cm (3 in.) from the side and 7.62 cm (3 in.) from the rear of the platform. Output during the test shall be monitored. A reference measurement shall be performed at the conclusion of this test. Performance shall conform to S39.13.

**S42.14 Pressure (EM Configuration)**—The resistance thermometers and thermocouple sensors under test, which will be used only for this one test, shall be installed in a fixture made from mild steel. The critical dimensions to which the fixture shall conform are shown in Fig. S7.0. The entire counterbored 1.9 cm (3/4-in.) diameter surface shall be babbitted over, using babbitt that conforms to grade 2 of Specification B23, flush with the top of the test fixture. The insulation resistance between each connecting wire and the babbitt surface shall then be measured. The babbitt surface shall then be exposed to a pressure of 12.4 MPa (1800 ± 10 lb/in.<sup>2</sup>) for 5 ± 0.25 min. After completion of this test, the insulation resistance shall be measured in the same manner as before the test. The fixture shall be unbabbitted and a reference measurement shall be performed. Performance shall conform to S39.14.

**S42.15 Scoring**—The resistance thermometers and thermocouple sensors under test, which will be used only for this one test, shall be installed in a fixture made from mild steel. The critical dimensions to which the fixture shall conform are shown in S39. The resistance thermometers and thermocouple sensors under test shall not contain a babbitt topping, and the connecting wire shall be severed. The entire 1.9 cm (3/4 in.) diameter counterbored surface shall be babbitted over using babbitt that conforms to Grade 2 of Specification B23 with 3 mm ± 254 μm (0.12 ± 0.01 in.) of the resistance thermometers and thermocouple sensors protruding above the babbitt surface. The protruding tip of the resistance thermometers and thermocouple sensors shall be brought into contact with a 5.08 cm ± 254 μm (2.00 ± 0.01 in.) diameter shaft that is rotating at 3000 ± 30 r/min. The shaft shall be made from carbon steel having a Brinell hardness between 170 and 180 and a surface finish between 15 and 25 root mean square (rms). A force of 3.63 kg ± 454 g (8 ± 1 lb) shall be applied to the resistance thermometers and thermocouple sensors to ensure contact with the circumference of the shaft during the test. The resistance thermometers and thermocouple sensors shall be oriented so that the axis perpendicular to their sensor tip face shall intersect and be perpendicular to the longitudinal axis of the shaft. Prior to the start of the test, the shaft and the fixture shall be cleaned with a suitable solvent and wiped dry. A stylus trace of the shaft surface parallel to the axis of the shaft shall be performed at six equally spaced intervals around the circumference of the shaft. No lubrication shall be used between the resistance thermom-

eters and thermocouple sensors and the shaft during the scoring test. The rotating shaft shall remove 2.54 mm ± 254 μm (0.10 ± 0.10 in.) of material from the protruding tip of the resistance thermometers or thermocouple sensors. Upon completion of the test, removal of any babbitt from the surface of the shaft shall be accomplished by the use of 20 % sodium hydroxide solution. A stylus trace of the shaft surface parallel to the axis of the shaft shall be performed at the same six equally spaced intervals around the circumference of the shaft. Performance shall conform to S39.15.

### S43. Inspection

**S43.1 Classification of Inspections**—The inspection requirements specified herein are classified as follows:

- (1) Qualification testing, and
- (2) Quality conformance testing.

#### S43.2 Qualification Testing:

**S43.2.1 Sample Size**—Unless otherwise specified, two resistance thermometers and thermocouple sensors of each configuration and range shall be subjected to qualification testing.

**S43.2.2 General Examination and Tests**—Qualification inspection shall consist of the general examination and tests specified in Table S20 in the order listed. Any deviation in the test order shall first be approved by the purchaser.

**TABLE S20 Qualification Testing**

Examination and Test	Performance Requirement	Test Method	Applicable Configurations	Conformance	
				Group A	Group B
General examination	---	S43.5	TW, BB, EM	X	---
Insulation resistance	S39.1	S42.1	---	---	---
Accuracy	S39.2	S42.2	TW, BB, EM	X <sup>A</sup>	X
Response time	S39.6	S42.3	TW, BB, EM	---	---
Self heating <sup>B</sup>	S39.4	S42.4	TW, BB, EM	---	X
Thermal cycling <sup>C</sup>	S39.5	S42.5	TW, BB, EM	---	X
Over-temperature <sup>C</sup>	S39.6	S42.6	EM	---	---
Terminal strength <sup>C</sup>	S39.7	S42.7	TW, EM	---	---
Connecting wire end closure	S39.8	S42.8	TW, BB	---	---
Enclosure <sup>D,C</sup>	S39.9	S42.9	TW, BB	---	---
Salt spray (fog) <sup>D,C</sup>	S39.10	S42.10	TW, BB, EM	---	---
Spring loading	S39.11	S42.11	TW	---	X
Vibration <sup>C</sup>	S39.12	S42.12	TW, BB, EM	---	---
Shock <sup>D,C</sup>	S39.13	S42.13	TW, BB, EM	---	---
Pressure <sup>D,C</sup>	S39.14	S42.14	EM	---	---
Scoring	S39.15	S42.15	EM	---	---

<sup>A</sup>A two point accuracy test at 0°C (32°F) and 100°C (212°F) shall be performed. Performance shall conform to S39.2.

<sup>B</sup>The self heating test shall be performed only on resistance thermometers.

<sup>C</sup>A reference measurement (see S42.2.2) shall be performed prior to and at the conclusion of this test. Performance shall conform to S39.2.2.

<sup>D</sup>An insulation resistance test shall be performed at the conclusion of this test. Performance shall conform to S42.1.

**S43.2.3 Acceptance Criteria**—The resistance thermometers and thermocouple sensors shall meet all the requirements of the general examination and tests listed in Table S20.

#### S43.3 Quality Conformance Inspection:

**S43.3.1 Inspection Lot**—An inspection lot shall consist of all resistance thermometers and thermocouple sensors of the same classification, produced under essentially the same conditions and offered for delivery at the same time.

**S43.3.2 Group A General Examination and Test**—Resistance thermometers and thermocouple sensors in each lot shall be subjected to the group A general examination and test specified in Table S20 in the order listed.

S43.3.3 *Group B General Examination and Test*—A sample resistance thermometer and thermocouple shall be randomly selected from each lot of 100 or more units, as appropriate, for the tests specified in Table S20. Group B tests shall be performed in the order listed on resistance thermometers and thermocouple sensors that have passed group A tests.

S43.3.4 *Acceptance Criteria:*

S43.3.4.1 *Acceptance Criteria for Group A*—The resistance thermometers and thermocouple sensors shall meet all the requirements of the group A general examination and tests in order to receive group A quality conformance inspection approval.

S43.3.4.2 *Acceptance Criteria for Group B*—Selected resistance thermometers and thermocouple sensors shall have passed the group A tests. If any resistance thermometer or thermocouple sensor fails in any test, no resistance thermometer or thermocouple sensor shall be accepted for quality conformance inspection until the contractor has determined the cause of the defect and has taken the necessary action to correct or eliminate the defects from resistance thermometers or thermocouple sensors on hand. The failed test and any other test required shall be repeated to demonstrate that the corrective action will enable the resistance thermometers or thermocouple sensors to conform to the requirements of this specification.

S43.4 *Test Conditions*—Except where the following factors are variables, the tests in this specification shall be conducted under the following conditions:

(1) Calibration bath temperature shall be plus or minus 2.8°C (5°F) from the specified temperature.

(2) Resistance thermometer element excitation current shall be  $1.0 \pm 0.1$  mA dc.

(3) Maximum immersion into the temperature bath shall be as follows:

(a) TW configuration—Immersion shall be to the thermowell insertion length minus 1.27 cm (0.5 in.).

(b) BB configuration—Immersion shall be to the “E” dimension minus the thread length 2.23 cm (0.875 in.).

(c) EM configuration—Each resistance thermometer or thermocouple sensor shall be placed in an individual stainless steel tube and packed with fine aluminum oxide powder. The stainless steel tube shall be immersed in the temperature bath fluid to a depth such that further immersion does not produce a change in the equivalent indicated temperature of more than twice the temperature bath fluid gradient.

(4) Unless otherwise specified, the test shall be performed with a sensor input current of 1 mA.

S43.5 *General Examination:*

S43.5.1 *Visual Examination*—Resistance thermometers and thermocouple sensors shall be given a thorough examination to determine that they conform to this specification and applicable drawings with respect to material, finish, workmanship, construction, assembly, dimensions, weight, marking of identification, and information plates. This examination shall be limited to those examinations that may be performed without disassembling the resistance thermometers and thermocouple sensors in such a manner that their performance, durability, or appearance will be affected.

S43.5.2 *Radiographic Examination (TW and BB Configuration)*—When required, the radiographic examination shall ensure that the resistance thermometer element, the thermocouple sensor’s measuring junction, and the connecting wires meet the requirements of S38.2.

S43.5.3 *Sheath Straightness (TW Configuration)*—A plain ring gauge having a  $6.53 \text{ cm} \pm 2.54 \mu\text{m}$  ( $0.2570 \pm 0.0001$  in.) diameter and a length which is at least the thermowell insertion length shall be used to verify the sheath straightness. The sheath shall pass through the plain ring gauge until it hits the first spring stop.

#### S44. Certification

S44.1 When specified in the purchase order or contract, the purchaser shall be furnished certification that samples representing each lot have been either tested or inspected as directed in this specification and the requirements have been met. When specified in the purchase order or contract, a report of the test result shall be furnished. It is recommended that all test data remain on file for three years at the manufacturer’s facility for review by purchaser upon request.

#### S45. Product Marking

S45.1 Product marking requirements shall be specified in the acquisition requirements.

S45.2 *Identification Plate*—The identification plate shall include at a minimum the following:

- (1) Nomenclature,
- (2) Contractor’s part number,
- (3) National Stock Number (NSN),
- (4) Contract number,
- (5) Detailed specification number,
- (6) Contractor’s name or CAGE code, and
- (7) Temperature range.

S45.3 *Sheath (TW and BB Configurations)*—Each sheath shall be clearly and permanently marked, that is, engraved or electronically etched with the Commercial and Government Entity (CAGE) number, the classification variables as specified in B4, and a model number.

S45.4 *Metallic Tag (EM Configuration)*—A metallic tag shall be placed at the end of the connecting wires opposite the sheath and shall be clearly and permanently marked with the same information as required in S45.3. The following notice shall be placed on the opposite side of the tag:

#### NOTICE

**Reattach this tag to the connecting wires after bearing installation and keep affixed to the connecting wires when the bearing is placed in service.**

S45.5 *Connecting Metal Link (TW Configuration)*—The connecting metal links on the connection head terminal board for resistance thermometers shall be marked “R” and “W,” respectively, for the red and white insulated connecting wires. The connecting metal links on the connection head terminal board for thermocouple sensors shall be marked “Y (+)” and “R(-)” for the yellow and red insulated connecting wires.



**S45.6 Connector Receptacle (BB Configuration)**—The connector receptacle pins for resistance thermometers with platinum elements shall be marked “B” for the single connecting wire on one side of the resistance thermometer element and shall be marked “A” and “C” for the two connecting wires on either side of the resistance thermometer element. The connector receptacle pins for resistance thermometers with nickel elements shall be marked “A” and “B” for the two connecting wires on each side of the resistance thermometer element. The connector receptacle pins for thermocouple sensors shall be marked “(+)” and “(-)” for the positive and negative connecting wire respectively.

**S45.7 Connecting Head Plate (TW Configuration)**—An identification plate shall be affixed to the connecting head cap.

## SENSORS, TEMPERATURE, FIBER OPTIC (NAVAL SHIPBOARD USE)

The following appendix to supplementary requirements established for U.S. Naval shipboard application shall apply when specified in the contract or purchase order. When there is conflict between the standard (ASTM F2362) and this supplement’s appendix, the requirements of this supplement’s appendix shall take precedence for equipment acquired by this supplement’s appendix. This document supercedes MIL-S-24795, Sensors, Temperature, Fiber Optic (Naval Shipboard Use), for new ship construction.

### S48. Scope

**S48.1** This supplement covers single-channel, fiber optic temperature sensors designed to meet the requirements for use onboard naval ships.

**S48.2** This specification covers the requirements for single-channel, fiber optic temperature sensors for general applications. The fiber optic temperature sensor usually consists of the sensor head that is in contact with the measured media, embedded in babbitt material, or housed inside a thermowell. Using connectorized fiber optic cable, a separate optoelectronics module translates the optical input to a continuous linear proportional analog electrical signal or other output signal such as optical or digital.

**S48.3** The U.S. Government preferred system of measurement is the metric SI system. However, since this item was originally designed using inch-pound units of measurement, in the event of conflict between the metric and inch-pound units, the inch-pound units shall take precedence.

### S49. Referenced Documents

**S49.1 Commercial Documents:**

**S49.1.1 ASTM Standards:**<sup>9</sup>

B23 Specification for White Metal Bearing Alloys Known Commercially as “Babbitt Metal”

B117 Test Method for Salt Spray (Fog) Testing

D542 Test Method for Index of Refraction of Transparent Organic Plastics

D570 Test Method for Water Absorption of Plastics

**S49.1.2 Other Commercial Documents:**

<sup>9</sup> For referenced ASTM standards, visit the ASTM website, [www.astm.org](http://www.astm.org), or contact ASTM Customer Service at [service@astm.org](mailto:service@astm.org). For *Annual Book of ASTM Standards* volume information, refer to the standard’s Document Summary page on the ASTM website.

### S46. Packaging and Package Marking

**S46.1** Packaging and package marking shall be in accordance with Section 15.

### S47. Quality Assurance Provisions

**S47.1 Warranty**—Special warranty requirements shall be specified in the acquisition requirements. Otherwise, the standard commercial warranty applies.

ANSI/ISA S37.1 Electrical Transducer Nomenclature and Terminology<sup>10</sup>

ASME PTC 19.3:1 Thermowells (Power Test Codes, Instruments and Apparatus, Part 3, Temperature Measurement)<sup>11</sup>

RS-422 Electrical Characteristics of Balanced Voltage Digital Interface Circuit<sup>12</sup>

**S49.2 Government Documents:**<sup>13</sup>

**S49.2.1 Military Standards:**

MIL-STD-167-1 Mechanical Vibrations of Shipboard Equipment (Type I—Environmental and Type II—Internally Excited)

MIL-STD-461 Requirements for Control of Electromagnetic Interference Characteristics of Subsystems and Equipment

MIL-STD-2042 Fiber Optic Topology Installation Standard Methods for Naval Ships

**S49.2.2 Military Specifications:**

MIL-S-901 Shock Tests, H.I. (High-Impact); Shipboard Machinery, Equipment Systems, Requirements for

MIL-C-5015 Connector, Electrical, Circular Threaded, AN Type, General Specification for

MIL-S-19622 Stuffing Tubes, Nylon; and Packing Assemblies; General Specification for

MIL-S-19622/1 Stuffing Tubes, Straight, Nylon

MIL-S-19622/17 Stuffing Tube, Nylon, Size 2: Packing Assemblies for

MIL-E-24142 Enclosures for Electrical Fittings and Fixtures, General Specification for

<sup>10</sup> Available from American National Standards Institute (ANSI), 25 W. 43rd St., 4th Floor, New York, NY 10036.

<sup>11</sup> Available from American Society of Mechanical Engineers (ASME), ASME International Headquarters, Three Park Ave., New York, NY 10016-5990.

<sup>12</sup> Available from Electronic Industries Alliance (EIA), 2500 Wilson Blvd., Arlington, VA 22201.

<sup>13</sup> Available from Standardization Documents Order Desk, DODSSP, Bldg. 4, Section D, 700 Robbins Ave., Philadelphia, PA 19111-5098.



MIL-E-24142/3 Enclosure for Electrical Fittings and Fixtures, Submersible, Size 6 by 9 (15 Foot)

MIL-M-24794 Material, Index Matching, Fiber Optics

MIL-F-49291 Fiber, Optical, (Metric), General Specification for

MIL-C-83522 Connectors, Fiber Optic, Single Terminus, General Specification for

MIL-C-83522/16 Connector, Fiber Optic, Single Terminus, Plug, Adapter Style, 2.5 Millimeter Bayonet Coupling, Epoxy

MIL-C-83522/17 Connector, Fiber Optic, Single Terminus, Adapter, 2.5 Millimeter Bayonet Coupling, Bulkhead Panel Mount

MIL-C-83522/18 Connector, Fiber Optic, Single Terminus, Adapter, 2.5 Millimeter Bayonet Coupling, PC Mount

MIL-C-85045 Cables, Fiber Optic, (Metric), General Specification for

MS3452 Connector, Receptacle, Electric, Box Mounting, Rear Release, Crimp Contact, AN Type with

MS3456 Connector, Plug, Electrical, Rear Release, Crimp Contact, AN Type

## S50. Terminology

S50.1 *Terminology Defined*—Terms marked with (ANSI/ISA S37.1) are taken directly from ANSI/ISA S37.1 (R-1982) and are included for the convenience of the reader.

S50.2 *Definitions*—Terminology consistent with ANSI/ISA S37.1 shall apply, except as modified by the definitions listed as follows:

S50.2.1 *ambient conditions*—conditions such as pressure and temperature of the medium surrounding the case of a sensor (ANSI/ISA S37.1).

S50.2.2 *babbitt*—metal material commonly used in bearing and temperature sensor installations which wears in with equipment operation providing a wear surface and heat transfer medium. Babbitt is softer than the base or substrate material and softer than mating component materials, where applicable.

S50.2.3 *bare-bulb type sensor head*—sensor head design where the sensing element is exposed directly to the process fluid being measured.

S50.2.4 *calibration*—test during which known values of measurands are applied to the sensor and corresponding output readings are recorded under specific conditions (ANSI/ISA S37.1).

S50.2.5 *embedded type sensor head*—sensor head design which is embedded in babbitt material which isolates the sensor element from the process fluid and, in some instances, moving or rotating components, but still allows the temperature to be monitored.

S50.2.6 *environmental conditions*—specified external conditions such as shock, vibration and temperature to which a sensor may be exposed during shipping, storage, handling, and operation (ANSI/ISA S37.1).

S50.2.7 *error*—algebraic difference between the indicated value and the true value of the measurand (ANSI/ISA S37.1).

S50.2.8 *fiber optic temperature sensor*—a device that converts sensed temperature to a proportional output signal via changes in fiber optic properties. The fiber optic temperature

sensor normally consists of a sensor head, opto-electronics module, and connectorized fiber optic cable.

S50.2.9 *hysteresis*—the difference in sensor output when compared at the same temperature under the same environmental conditions with one data point taken with ascending temperature and another with descending temperature.

S50.2.10 *operating environmental conditions*—environmental conditions during exposure to which a sensor must perform in some specified manner (ANSI/ISA S37.1).

S50.2.11 *optical*—involving the use of light sensitive devices to acquire information.

S50.2.12 *optical fiber*—a very thin filament or fiber, made of dielectric materials, that is enclosed by material of lower index of refraction and transmits light throughout its length by internal reflections.

S50.2.13 *opto-electronics module*—a component of the fiber optic temperature sensor that contains the optical source and detector, and signal conditioner devices necessary to convert the sensed temperature to a specified output signal.

S50.2.14 *output*—electrical or numerical quantity, produced by a sensor or measurement system, that is a function of the applied measurand.

S50.2.15 *range*—measurand values over which a sensor is intended to measure, specified by their upper and lower limits (ANSI/ISA S37.1).

S50.2.16 *repeatability*—ability of a sensor to reproduce output readings when the same measurand value is applied to it consecutively, under the same conditions, and in the same direction (ANSI/ISA S37.1).

S50.2.17 *response time*—the time required for a sensor to indicate a step change in temperature or the time difference between an actual step change in temperature applied and the corresponding change in sensor output.

S50.2.18 *sensitivity factor*—the ratio of fiber optic temperature sensor output signal percentage change of span to applied bath temperature percentage change of span.

S50.2.19 *sensor element*—that part of the sensor that responds directly to the measurand (ANSI/ISA S37.1).

S50.2.20 *sensor head*—the transduction element of a fiber optic temperature sensor that detects temperature via changes in optical properties.

S50.2.21 *sheath*—the protective covering of a sensor element.

S50.2.22 *SI (Le Systeme International d'Unites) units*—units of measurement recognized by the CIPM (Comite' International des Poids et Mesures).

S50.2.23 *signal conditioner*—an electronic device that makes the output signal from a transduction element compatible with a readout system.

S50.2.24 *span*—the algebraic difference between the limits of the measurement range.

S50.2.25 *static error band*—the maximum deviation from a straight line drawn through the coordinates of the lower range limit at specified sensor output and the upper range limit at specified output expressed in percentage of sensor span.

S50.2.26 *thermowell*—a pressure tight receptacle adapted to receive a temperature sensing element and provided with the external threads or other means for pressure tight attachment to the vessel.

S50.2.27 *thermowell type sensor head*—sensor head design which is intended to be used with a thermowell which isolates the sensor element from the process fluid being measured while maintaining the pressure boundary.

S50.2.28 *warm-up time*—the time required for a sensor to operate within specified requirements after being re-energized from a cold (ambient) state.

## S51. Classification

S51.1 *Design Type*—The fiber optic temperature sensor shall consist of a series of designations which shall be assigned and listed in the format below.

Example: ASTM F2362S48-T4-DC-A-VC-2

Specification	Type	Input Power	Opto-Electronics Module	Signal Output	Range
F2362S48	T4 S51.2	DC S51.3	A S51.4	VC S51.5	2 S51.6

S51.2 *Type*—The sensor head type shall be designated as follows:

T1—Thermowell (see Fig. S8.0 and Fig. S9.0)

T2—Thermowell (see Fig. S8.0 and Fig. S9.0)

T3—Thermowell (see Fig. S8.0 and Fig. S9.0)

T4—Thermowell (see Fig. S8.0 and Fig. S9.0)

EM—Embedded (Bearing Applications, see Fig. S8.0 and Fig. S10.0)

B1—Bare-bulb (see Fig. S11.0)

B2—Bare-bulb (see Fig. S11.0)

S51.3 *Input Power*—The input power required to operate the opto-electronics module shall be designated as follows:

DC—28 V direct current (Vdc)

AC—115 V alternating current (Vac)

S51.4 *Opto-electronics Module*—The opto-electronics module type shall be designated as follows:

A—Junction box enclosure

B—Control console module

C—Monitoring and alarm panel module

S51.5 *Signal Output*—The signal output shall be designated as follows:

A—4 to 20 mA dc

VA—0 to 5 Vdc

VB—0 to 10 Vdc

VC—0 to 12 Vdc

VS—Specified

O—Digital optical output

E—Digital electrical output

S51.6 *Range*—The sensor measurement range shall be designated as follows:

1: -40 to 150°C (-40 to 302°F)

2: 0 to 300°C (32 to 572°F)

3: -40 to 300°C (-40 to 572°F)

## S52. Ordering Information

S52.1 The purchaser shall provide the manufacturer with all of the pertinent application data shown in accordance with S52.2. If special application operating conditions exist that are not shown in the acquisition requirements, they shall also be described.

S52.1 *Acquisition Requirements*—Acquisition documents should specify the following:

(1) Title, number, and date of this specification,

(2) Quantity of fiber optic temperature sensors required,

(3) Fiber optic temperature sensor classification required:

(a) Sensor type,

(b) Input power,

(c) Opto-electronics module,

(d) Signal output, and

(e) Range.

(4) When qualification inspection is required,

(5) Final disposition of qualification test samples,

(6) National Stock Number (NSN) if available,

(7) Unique product marking requirements, and

(8) Unique preservation, packaging and marking requirements.

## S53. Materials and Manufacture

S53.1 *Sensing Elements*—The materials for all wetted parts shall be selected for long term compatibility with the process medium. For example, corrosion resistant steel or monel are compatible with long term exposure to seawater.

S53.2 *Metals*—Unless otherwise specified herein, all metals used in the construction of the sensor shall be corrosion resistant. Dissimilar metals shall not be used in close physical contact with each other unless suitably finished to prevent electrolytic corrosion. Materials used to fabricate the sensor head for the embedded configuration shall have a Brinell hardness less than 170 to ensure that shaft scoring does not occur.

S53.3 *Flammable Materials*—Materials used in the construction of the sensor shall, in the end configuration, be noncombustible or fire retardant in the most hazardous conditions of atmosphere, pressure and temperature to be expected in the application. Fire retardant additives may be used provided they do not adversely affect the specified performance requirements of the basic materials. Fire retardance shall not be achieved by use of nonpermanent additives to the basic material.

S53.4 *Fungus Resistant Materials*—Materials used in the construction of the sensor shall be fungus inert materials.

S53.5 *Solvents, Adhesives, and Cleaning Agents*—If any chemicals or cements are used in bonding of internal components, no degradation shall result during in-service use.

S53.6 *Refractive Index Matching Gels, Fluids, or Compounds*—Refractive index matching gels, fluids, or compounds shall be in accordance with MIL-M-24794 and shall not produce toxic, corrosive, or explosive byproducts. The material is subject to a toxicological data and formulations review and inspection, for safety of material, by the purchaser. The index matching material shall be either silicone or aliphatic hydrocarbon material and shall be clear and transparent.

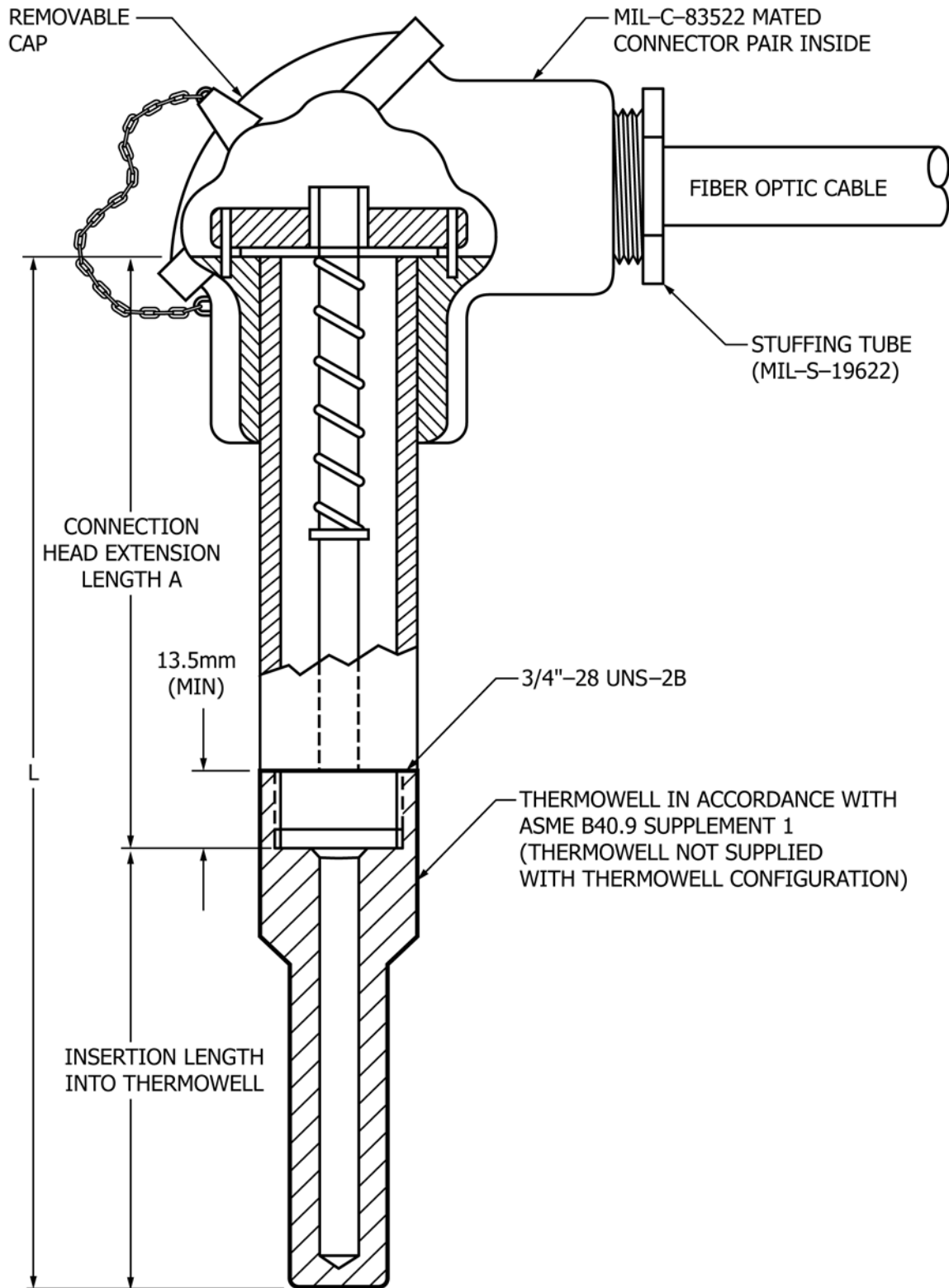

FIG. S8.0 Thermowell Type Sensor Head Assembly

The index matching material shall have an index of refraction of  $1.46 \pm 0.01$  as tested in accordance with Test Method D542 when exposed to operating temperature extremes between  $-28^{\circ}\text{C}$  and  $+85^{\circ}\text{C}$  ( $-18.4$  and  $185^{\circ}\text{F}$ ). The index matching material shall not flow at elevated temperatures. The index

matching material shall remain clear and transparent when tested for water absorption in accordance with Test Method D570. The index matching material shall have a shelf life not less than 36 months at  $25 \pm 5^{\circ}\text{C}$  ( $77 \pm 9^{\circ}\text{F}$ ). The 36 month period commences on the date of adhesive manufacture.

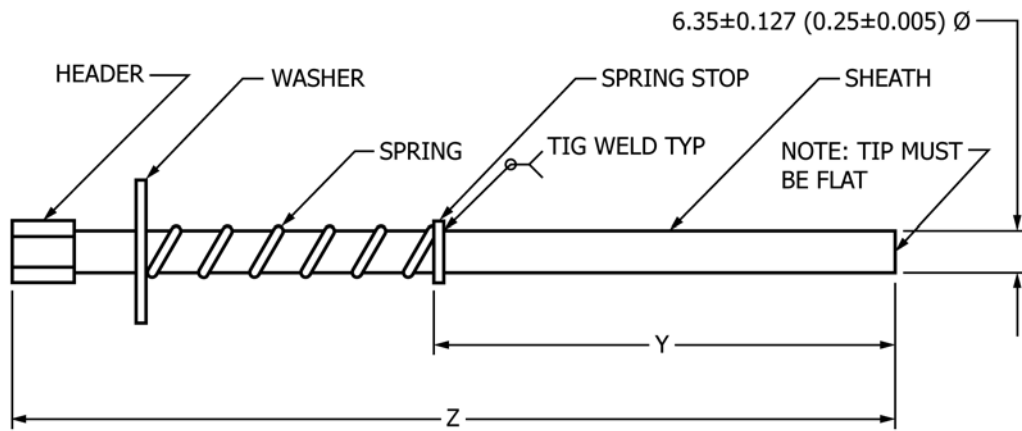

FIG. S9.0 Sensor Head Sheath Construction

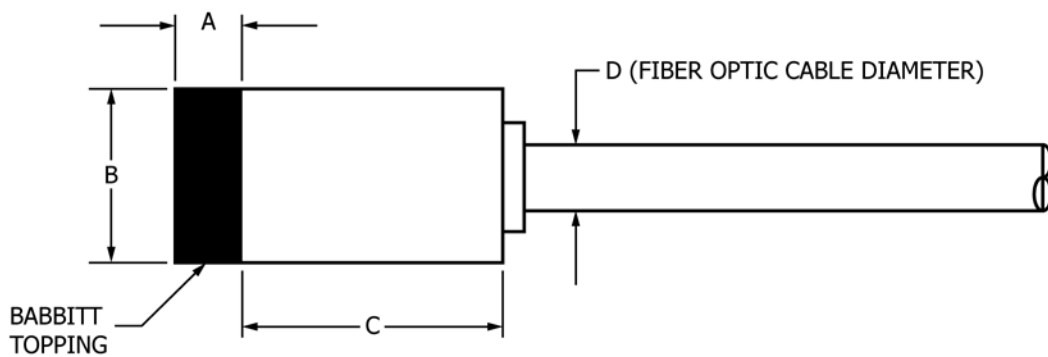

FIG. S10.0 Embedded Type Sensor Head Assembly

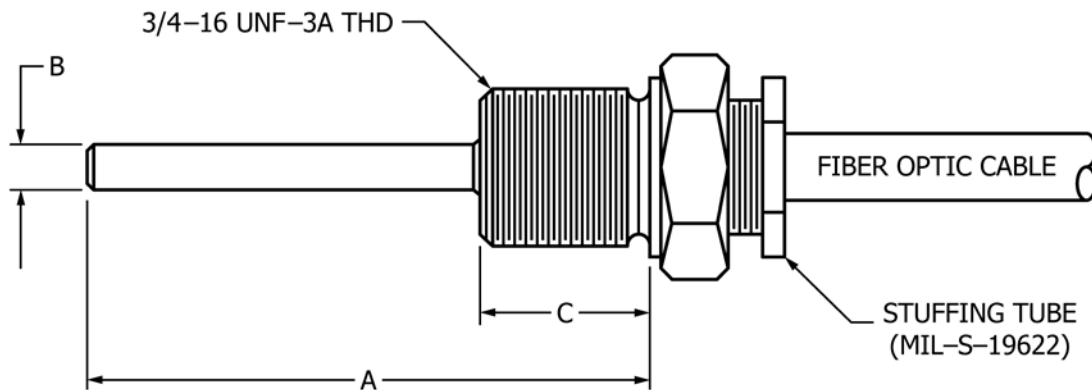

FIG. S11.0 Bare-bulb Type Sensor Head Assembly

## S54. Physical Properties

Fiber optic temperature sensors convert the thermal energy surrounding the sensor head to a continuous linear analog dc signal or specified digital output throughout a specified measurement range. The fiber optic temperature sensor shall consist of a sensor head, opto-electronics module, and fiber optic cable interconnect. All parts of the fiber optic temperature sensor shall be interchangeable with the appropriate replacement parts with respect to form, fit, and function, and maintain the specified accuracy requirements.

S54.1 *Sensor Head*—The sensor head shall detect the surrounding temperature. The sensor head shall be passive in nature by detection of temperature through a change in optical

properties. Neither electrical nor electronic components shall be used in the construction of the sensor head.

S54.1.1 *Thermowell Type*—The sensor head shall be constructed in accordance with Fig. S8.0 and Fig. S9.0. The sensor head dimensions shall be in accordance with Fig. S8.0 and Fig. S9.0. The sensor head shall have a weight not greater than 1 kg.

S54.1.2 *Embedded Type*—The sensor head shall be constructed in accordance with the dimensions shown in Fig. S10.0. The babbitt topping material shall be in accordance with Specification B23 (grade 2).

S54.1.3 *Bare-bulb Type*—The bare-bulb type sensor head dimensions shall be in accordance with Fig. S11.0. The sensor head shall have a weight not greater than 1 kg (2.2 lb). The



sensor sheath shall be designed to withstand application conditions of 37.66 Mpa (5500 pounds per square inch), 210°C (410°F), and an open air flow velocity of 12.2 m (40 ft) per second. Conformance shall be proven by using a mathematical model approved by the Power Test Code Thermometer Wells, ASME PTC 19.3:1.

#### S54.2 *Opto-electronics Module:*

S54.2.1 *Junction Box Enclosure (Type A)*—The opto-electronics shall be housed in a junction box. MIL-E-24142 and MIL-E-24142/3 may be used as guidance for the junction box. At a minimum, the dimensions, mounting requirements, and cable entrance shall be in accordance with MIL-E-24142 and MIL-E-24142/3. The opto-electronics module shall have a weight no greater than 4.5 kg (9.92 lb).

S54.2.2 *Control Console Module (Type B)*—The opto-electronics shall be packaged in a circuit card which is a modular subassembly of a control console. Design and test requirements for the opto-electronics module shall be as specified in the acquisition requirements.

S54.2.3 *Monitoring and Alarm Panel Module (Type C)*—The opto-electronics shall be packaged in a module which is a subassembly of a bulkhead mounted temperature monitoring and alarm panel. Design and test requirements for the opto-electronics module shall be as specified in the acquisition requirements.

#### S54.3 *Fiber Optic Cable:*

S54.3.1 *Thermowell and Bare-bulb Sensor Types*—The cable used to interface the sensor head and the opto-electronics module shall have an outer diameter of a four fiber cable in accordance with MIL-C 85045. In the cable, there shall be no less than two times the number of fibers required for operation of the sensor. The cable shall be supplied with a stuffing tube (size 2, military part number M19622/1-002 in accordance with MIL-S-19662/1), and packing assembly (military part number M19622-17-0001 in accordance with MIL-S-19662/17) in accordance with MIL-S-19622, and an o-ring installed on each end of the cable to accomplish watertight penetration into the sensor head and opto-electronic module. The o-rings used shall be petroleum hydraulic fluid resistant and shall be rated to perform in high temperature applications 135°C (275°F). Exposed single fiber optical fiber cable component shall not be used over distances greater than one meter. The cable length shall be as specified in the acquisition requirements.

S54.3.2 *Embedded Sensor Type*—The cable used to interface the sensor head and a local interconnection box shall be in accordance with MIL-C-85045. The cable length shall be as specified in the acquisition requirements.

S54.3.3 *Optical Fiber*—Optical fiber used to transmit light between the opto-electronics module and the sensor head shall be in accordance with MIL-F-49291.

S54.3.4 *Fiber Optic Connectors, Receptacles, and Bulkhead Adapters*—All fiber optic connectors, receptacles, and bulkhead adapters shall be in accordance with MIL-C-83522 and MIL-C-83522/16,17, and 18, respectively. The fiber optic cable for the thermowell sensor type shall be terminated at both ends with connectors. The fiber optic cable for the embedded and bare-bulb sensor configurations shall be terminated with a

connector at the end which interfaces with the opto-electronic module. MIL-STD-2042 method 5B1 may be used as guidance. The connectors and receptacles shall be mounted inside the sensor head (thermowell sensor type only) and the opto-electronic module.

S54.3.5 *Electrical Input Power*—Nominal steady-state power supply requirements for ac shall be  $115 \pm 8$  Vac, 60 Hertz, single phase. Nominal steady-state power supply requirements for dc shall be  $28 \pm 4.5$  Vdc. The sensor shall operate with power supply variations as specified (see S58.8.1 through S58.8.6).

#### S54.3.6 *Output Signal:*

S54.3.6.1 *Current Output*—When a current output is required, the output signal shall be directly proportional to the temperature being measured. The 4 mA output shall correspond to the lower temperature range value and the 20 mA output shall correspond to the upper temperature range value. The current output shall remain accurate regardless of external load resistance variations over a range of 0 to 250  $\Omega$ .

S54.3.6.2 *Voltage Output*—When a voltage output is required, the output signal shall be directly proportional to the temperature being measured. The lower dc voltage output shall correspond to the lower temperature range value and the higher dc voltage output shall correspond to the upper temperature range value. The voltage output shall remain accurate regardless of external load resistance greater than 1000  $\Omega$ . Typical voltage outputs include 0-5 Vdc, 0-10 Vdc and 0-12 Vdc.

S54.3.6.3 *Digital Optical Output*—When a digital optical output is required, the output signal specifications shall be specified in the acquisition requirements.

S54.3.6.4 *Digital Electrical Output*—When a digital electrical output is required, the electrical characteristics shall be those specified in EIA standards RS-422 for balanced voltage digital interface circuitry or as specified in the acquisition requirements. The data format shall also be specified in the acquisition requirements.

S54.3.7 *Electrical Connectors*—A single electrical receptacle in accordance with MIL-C-5015 shall be used to interface with the input power and linear output signal to the opto-electronics module. When a digital optical or digital electrical output signal is specified, connectors shall be as specified in the acquisition requirements. The appropriate connector assembly and pin designations for each of the possible fiber optic temperature configurations shall be as specified as follows.

S54.3.7.1 *DC Input Power*—The receptacle mounted to the opto-electronics module shall be classification MS3452W14S-5PX in accordance with MS3452. Receptacle pin “A” shall be positive 28Vdc input power, pin “B” shall be negative 28Vdc input power, pin “C” shall be the case ground, pin “D” shall be positive mA or high Vdc output signal, and pin “E” shall be the negative mA or low Vdc output signal. The mating plug supplied with the fiber optic temperature sensor shall be classification MS3456W14S-5SX in accordance with MS3456.

S54.3.7.2 *AC Input Power*—The receptacle mounted to the opto-electronics module shall be classification MS3452W14S-5PX in accordance with MS3452. Receptacle pin “A” shall be positive 115 Vac input power, pin “B” shall be input power return, pin “C” shall be the case ground, pin “D” shall be

positive mA or high Vdc output signal, and pin “E” shall be the negative mA or low Vdc output signal. The mating plug supplied with the fiber optic temperature sensor shall be classification MS3456W14S-5SX in accordance with MS3456.

S54.3.8 *Adjustments*—A means may be provided for adjusting the output signal of the opto-electronics module for calibration purposes. If provided, the adjustments shall be situated in the opto-electronics module so that calibrations can be performed with the fiber optic temperature sensor energized.

S54.3.9 *Fuses*—The opto-electronics module shall not be fused.

## S55. Performance Requirements

S55.1 *Accuracy*—The fiber optic temperature sensor output signal accuracy shall be within  $\pm 1$  % of span (see S58.1).

S55.2 *Repeatability*—The fiber optic temperature sensor output signal repeatability at each temperature point shall not change in value more than 0.5 % of span (see S58.2).

S55.3 *Reference Measurement*—The fiber optic temperature sensor output signal accuracy shall be within  $\pm 1$  % of span (see S58.3).

S55.4 *Sensitivity Factor*—The ratio of the fiber optic temperature sensor output signal percentage change of span to applied bath temperature percentage change of span shall not be less than 0.75 nor greater than 1.25 (see S58.4).

S55.5 *Response Time*—Response time of the fiber optic temperature sensor output signal accuracy shall be not greater than 8 s for the thermowell sensor type, not greater than 5 s for the embedded sensor type, and not greater than 15 s for the bare-bulb sensor type (see S58.5).

S55.6 *Warm-up Time*—The fiber optic temperature sensor output signal accuracy at the bath temperature shall be within  $\pm 1$  % of span within 1 min after the sensor is energized (see S58.6).

S55.7 *Steady-state Supply Voltage and Frequency (AC) or Supply Voltage (DC)*—The fiber optic temperature sensor output signal shall be within  $\pm 1$  % of span throughout the limits of supply voltage and frequency (see S58.7).

S55.8 *Transient Voltage and Frequency (AC) or Voltage (DC)*—The fiber optic temperature sensor output signal accuracy shall be within  $\pm 1$  % of span when subjected to transient voltage and frequency (see S58.8).

S55.9 *Insulation Resistance*—The insulation resistance of the fiber optic temperature sensor between circuits and between circuits and ground shall not be less than 10 megohms (see S58.9).

S55.10 *Power Interruption*—The fiber optic temperature sensor output signal accuracy shall be  $\pm 1$  % of span during short duration power interruptions (see S58.10).

S55.11 *Short Circuit*—The fiber optic temperature sensor output signal accuracy shall be within  $\pm 1$  % of span after short circuit of the output signal lines (see S58.11).

S55.12 *Line Voltage Reversal (DC)*—The fiber optic temperature sensor output signal accuracy shall be within  $\pm 1$  % of span after reversal of the input dc power lines (see S58.12).

S55.13 *Temperature*—The fiber optic temperature sensor output signal accuracy shall be within  $\pm 1$  % of span over the ambient temperature range of 0 to 65°C (32 to 149°F) (see S58.13).

S55.14 *Enclosure*—The fiber optic temperature sensor output signal accuracy shall be within  $\pm 1$  % of span after exposure to a coarse stream of water (see S58.14).

S55.15 *Salt Spray*—No corrosion or other damage shall be evident when exposed to salt spray and the fiber optic temperature sensor output signal accuracy shall be within  $\pm 1$  % of span (see S58.15).

S55.16 *Over-temperature*—The sensor head shall show no evidence of physical damage when exposed to the limits of over-temperature and the reference measurement results shall conform to S55.3 (see S58.16).

S55.17 *Accelerated Life*—The sensor head shall show no evidence of physical damage when exposed to operating conditions which simulate accelerated life and the reference measurement results shall conform to S55.3 (see S58.17).

S55.18 *Vibration*—The fiber optic temperature sensor shall operate without interruption and show no evidence of physical damage when exposed to vibration in accordance with MIL-STD-167-1. The reference measurement results shall conform to S55.3 (see S58.18).

S55.19 *Shock*—The fiber optic temperature sensor shall operate without interruption and show no evidence of physical damage when exposed to shock in accordance with MIL-S-901. The reference measurement results shall conform to S55.3 (see S58.19).

S55.20 *Electromagnetic Interference (EMI) Emission and Susceptibility*—The fiber optic temperature sensor shall be in accordance with the requirements of MIL-STD-461 revision E, or later: CE101 (Submarine application only), CE102, CS101, CS114, CS116, RE101, RE102, RS101, and RS103 (see S58.20).

S55.21 *Pressure*—The fiber optic temperature sensor shall operate without interruption when exposed to a babbitt surface pressure of 12.4 MPa (1800 psi). The reference measurement shall conform to S55.3 (see S58.21).

## S56. Workmanship, Finish, and Appearance

S56.1 *Cleaning and Surface Finishes*—Surfaces of castings, forgings, molded parts, stampings, machined and welded parts shall be free of defects such as cracks, porosity, undercuts, voids and gaps as well as sand, dirt, fins, sharp edges, scale, flux, and other harmful or extraneous materials. External surfaces shall be smooth and edges shall be either rounded or beveled. There shall be no burn-through. There shall be no warpage or dimensional change due to heat from welding operation. There shall be no damage to adjacent parts resulting from welding.

## S57. Number of Tests and Retests

S57.1 The number of tests and retests, if any, shall be specified in the acquisition requirements.

## S58. Test Methods

S58.1 *Accuracy*—The sensitive portion of the sensor head shall be immersed in a temperature bath and the fiber optic temperature sensor output signal shall be measured at 5, 25, 50, 75 and 95 % of the fiber optic temperature sensor span. Accuracy shall conform to S55.1.

**S58.2 Repeatability**—The procedure specified in S58.1 shall be repeated three successive times while maintaining temperature bath conditions. The fiber optic temperature sensor head shall be removed from the bath for not less than 2 min and re-immersed at a repeatable depth for consecutive measurements at each of the five temperature points. The fiber optic temperature sensor output signal shall conform to S55.2.

**S58.3 Reference Measurement**—The sensitive portion of the sensor head shall be immersed in a temperature bath and the fiber optic temperature sensor output signal shall be measured at 5, 50, and 95 % of the fiber optic temperature sensor span. System accuracy shall conform to S55.1.

**S58.4 Sensitivity Factor**—The sensitivity factor shall be determined using the following procedure. Immerse the sensitive portion of the sensor head in a temperature bath and allow ample time to stabilize at a temperature of  $80 \pm 5$  % of span. Measure both the bath temperature and the fiber optic temperature sensor output signal. Increase the bath temperature by an amount not greater than 1 % of the fiber optic temperature sensor span. Measure both the new bath temperature and the fiber optic temperature sensor output signal. Calculate the change in both bath temperature and fiber optic temperature sensor output signal as a percentage of the fiber optic temperature sensor span. Determine the ratio of the output signal percentage change to applied bath temperature percentage change in terms of fiber optic temperature sensor span. Repeat this procedure for a bath temperature decrease not greater than 1 % of span. Performance shall conform to S55.4.

**S58.5 Response Time**—The response of the fiber optic temperature sensor shall be determined using the following procedure:

- (1) Bath medium: water
- (2) Origin bath temperature: 10°C (50°F)
- (3) Destination bath temperature: 82°C (180°F)
- (4) Initial temperature (T1): 26°C (79°F)
- (5) Final temperature (T2): 62°C (144°F)

The response time shall be determined as the time required for the fiber optic temperature sensor output signal to track from T1 to T2 after the sensor head is transferred from the origin bath to the destination bath. The response time of the fiber optic temperature sensor shall be the average of not less than six readings taken during not less than six consecutive trials. Performance shall conform to S55.5.

**S58.6 Warm-up Time**—Warm-up time shall be determined using the following procedure. Allow the sensitive portion of the sensor head to stabilize at a bath temperature of  $80 \pm 5$  % of the fiber optic temperature sensor span. De-energize the fiber optic temperature sensor for no less than 2 h. Energize the fiber optic temperature sensor and monitor the output signal as necessary to ensure conformance to S55.6.

**S58.7 Steady-state Supply Voltage and Frequency (AC) or Supply Voltage (DC)**—The fiber optic temperature sensor output signal shall be monitored for no less than 15 min at normal, maximum, and minimum steady-state voltage and frequency conditions as specified in S58.8. The fiber optic temperature sensor shall be subjected to each of the applicable power supply conditions for no less than 1 h at ambient temperatures of 0, 25, and 65°C (32, 77, and 149°F). The fiber

optic temperature sensor signal output shall be measured after not less than 1 h at each test condition. This test may be performed in conjunction with the temperature test (see S58.13). Performance shall conform to S55.7.

**S58.8 Transient Supply Voltage and Frequency (AC) or Supply Voltage (DC)**—The fiber optic temperature sensor output signal shall be monitored at ambient temperature during each test procedure defined below. Performance shall conform to S55.8.

**S58.8.1 Transient Voltage Upper Limit (AC)**—With the fiber optic temperature sensor operating at a voltage of 123 Vac, the voltage shall be increased to 138 Vac, and then decreased back to the steady-state voltage of 123 Vac in a 2 s period.

**S58.8.2 Transient Voltage Lower Limit (AC)**—With the fiber optic temperature sensor operating at a voltage of 107 Vac, the voltage shall be decreased to 92 Vac, and then increased back to the steady-state voltage of 107 Vac in a 2 s period.

**S58.8.3 Transient Frequency Upper Limit (AC)**—With the fiber optic temperature sensor operating at a frequency of 62 Hz, the frequency shall be increased to 63.5 Hz, and then decreased back to the steady-state frequency of 62 Hz in a 2 s period.

**S58.8.4 Transient frequency lower limit (AC)**—With the fiber optic temperature sensor operating at a frequency of 58 Hz, the frequency shall be decreased to 56.5 Hz, and then increased back to the steady-state frequency of 58 Hz in a 2 s period.

**S58.8.5 Transient Voltage Upper Limit (DC)**—With the fiber optic temperature sensor operating at a voltage of 32.5 Vdc, the voltage shall be increased to 34.5 Vdc, and then decreased back to the steady-state voltage of 32.5 Vdc in a 2 s period.

**S58.8.6 Transient Voltage Lower Limit (DC)**—With the fiber optic temperature sensor operating at a voltage of 23.5 Vdc, the voltage shall be decreased to 21.5 Vdc, and then increased back to the steady-state voltage of 23.5 Vdc in a 2 s period.

**S58.9 Insulation Resistance**—The insulation resistance of the opto-electronics module circuits shall be determined by applying 50 Vdc between electrical input and output circuits and between these circuits and the ground. The insulation resistance measurement shall be made immediately after a 2 min period of uninterrupted test voltage application. If the indication of insulation resistance meets the specified limit (see S55.9) and is steady or increasing, the test may be terminated before the end of the 2 min period. Performance shall conform to S55.9.

**S58.10 Power Interruption**—The fiber optic temperature sensor shall be energized and the output signal monitored at ambient temperature throughout the test. The external power supply shall be suddenly interrupted, and after an interval not less than 4 s, the power supply shall be reapplied to the fiber optic temperature sensor. Performance shall conform to S55.10.

**S58.11 Short Circuit**—The fiber optic temperature sensor shall be de-energized and the positive and negative electrical output terminals of opto-electronics module shall be connected directly together, with no load resistance. The fiber optic



temperature sensor shall be energized for 5 min, then deenergized and the short circuit removed. The fiber optic temperature sensor shall be energized and the output signal measured at ambient temperature. Performance shall conform to S55.11.

**S58.12 Line Voltage Reversal (DC)**—The positive 28 Vdc power input shall be applied to connector pin “B” and the reference shall be applied to connector pin “A.” The power supply shall be energized for a period of no less than 10 min. The fiber optic temperature sensor output signal shall be measured at ambient temperature. The fiber optic temperature sensor shall be de-energized and the power supply connections shall be reversed to normal polarity. The fiber optic temperature sensor shall then be energized for no less than 5 min before the output signal is measured at ambient temperature. Performance shall conform to S55.12.

**S58.13 Temperature**—The fiber optic temperature sensor shall be positioned in an environmental chamber in an energized state, and shall be subjected to the following conditions consecutively:

- (1) Hold temperature at  $0 \pm 2^\circ\text{C}$  ( $32 \pm 3.6^\circ\text{F}$ ) for 24 h,
- (2) Increase temperature in steps of  $10^\circ\text{C}$  ( $18^\circ\text{F}$ ) at 30 min per step until  $65 \pm 2^\circ\text{C}$  ( $149 \pm 3.6^\circ\text{F}$ ) is achieved,
- (3) Hold temperature at  $65 \pm 2^\circ\text{C}$  ( $149 \pm 3.6^\circ\text{F}$ ) for 24 h, and
- (4) Reduce temperature in steps of  $10^\circ\text{C}$  ( $18^\circ\text{F}$ ) at 30 min per step until  $25 \pm 2^\circ\text{C}$  ( $77 \pm 3.6^\circ\text{F}$ ) is achieved.

Measure the fiber optic temperature sensor output signal at one point during the last hour of operation at each temperature plateau, that is 0, 25, and  $65^\circ\text{C}$  (32, 77, and  $149^\circ\text{F}$ ). Performance shall conform to S55.13.

**S58.14 Enclosure**—The fiber optic temperature sensor head and no less than a two meter section of the attached cable interconnect shall be mounted to a surface which extends no less than 1 m (3.28 ft) beyond the sensor head on all sides so that splashing shall be produced by directing the water stream on that surface. The fiber optic temperature sensor shall be de-energized throughout the test. The water stream shall be a coarse spray with a flow rate of no less than 57 L (15 gal) per second and a head pressure of no less than 3 m (9.84 ft). A head pressure of 3 m (9.84 ft) is defined as sufficient water pressure so that if directed straight up, the stream of water shall rise to a height of no less than 3 m (9.84 ft). The distance from the nozzle to the enclosure under test shall be approximately 2 m (6.56 ft). The time of the test shall be no less than 5 min with approximately equal portions of time for spray on each surface, including joints of the enclosure and at the surface at which the enclosed equipment is mounted. The fiber optic temperature sensor components shall be examined at the immediate conclusion of the test for moisture penetration. The fiber optic temperature sensor shall be energized and the output signal monitored at ambient temperature at the conclusion the test. Performance shall conform to S55.14.

**S58.15 Salt Spray (Fog)**—The fiber optic temperature sensor head and no less than a 1 m (3.28 ft) section of the attached cable interconnect shall be subjected to salt spray in accordance with Test Method B117. This test is not applicable to the embedded sensor configuration since it will be secured in a bearing. The fiber optic temperature sensor shall be de-

energized throughout the test. Duration of the test shall be 96 h. The fiber optic temperature sensor components shall be examined at the immediate conclusion of the test for corrosion and moisture penetration. The fiber optic temperature sensor shall be energized and the output signal monitored at ambient temperature at the conclusion of the test. Performance shall conform to S55.15.

**S58.16 Over-temperature**—The sensitive portion of the fiber optic temperature sensor head shall be rapidly transferred from ambient conditions to a temperature bath stabilized at 125 % of the fiber optic temperature sensor full scale temperature. The sensor head shall remain immersed in the bath for 15 min and then returned to ambient conditions. A reference measurement (see S55.3) shall be performed at the conclusion of the over-temperature test. Performance shall conform to S55.16.

**S58.17 Accelerated Life**—The sensitive portion of the sensor head shall be thermally cycled between the following temperatures for 1500 cycles at a rate not greater than 2 cycles per minute:

Sensor Range	Temperature Cycling Points
-40 to $150^\circ\text{C}$ ( $-40$ to $302^\circ\text{F}$ )	Ambient to $-30 \pm 2^\circ\text{C}$ ( $-22 \pm 3.6^\circ\text{F}$ )
0 to $300^\circ\text{C}$ (32 to $572^\circ\text{F}$ )	Ambient to $285 \pm 2^\circ\text{C}$ ( $545 \pm 3.6^\circ\text{F}$ )

The fiber optic temperature sensor output signal shall be monitored during thermal cycling and observed for operation without interruption. A reference measurement (see S55.3) shall be performed at the conclusion of the thermal cycling test. Performance shall conform to S55.17.

**S58.18 Vibration**—The fiber optic temperature sensor shall be tested in accordance with MIL-STD-167-1, type 1. Test fixtures shall be designed to simulate the shipboard installation of the sensor type. The fiber optic temperature sensor output signal shall be monitored throughout the test and visually examined for operation without interruption, especially at resonant frequencies. The fiber optic temperature sensor shall be visually examined for physical damage during and at the conclusion of the test. A reference measurement in accordance with S55.3 shall be performed at the conclusion of the test. Performance shall conform to S55.18.

**S58.19 Shock**—The fiber optic temperature sensor shall be fully assembled, energized, and tested in accordance with grade A, class 1, type A of MIL-S-901. Test fixtures shall be designed to simulate the shipboard installation of the sensor type. The fiber optic temperature sensor shall be visually examined for physical damage after each hammer blow and at the conclusion of the test. A reference measurement in accordance with S55.3 shall be performed at the conclusion of the test. Performance shall conform to S55.19.

**S58.20 EMI Emission and Susceptibility**—EMI tests shall be in accordance with the test methods specified in MIL-STD-461 revision E, or later. Performance shall conform to S55.20.

**S58.21 Pressure**—A reference measurement (see S55.3) shall be performed prior to the test to ensure the sensor head is not defective. The sensor head under test shall be installed in a fixture made from mild steel. The critical dimensions to which the fixture shall conform are shown on Fig. S12.0. The 19.05 mm (0.75 in.) diameter counterbore shall contain Specification (grade 2) babbitt flush with the test fixture surface. The babbitt surface shall then be exposed to a gauge pressure of  $12.411 \pm$



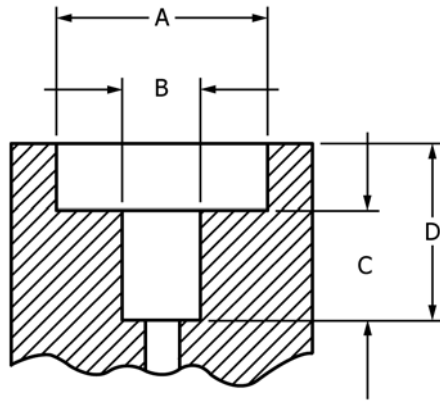

FIG. S12.0 Pressure Test Fixture

0.07 MPa (1800 ± 10 pounds per square inch) for not less than 5 min. The fiber optic temperature sensor output signal shall be monitored during the test and examined for operation without interruption. The babbitt shall be removed from the 19.05 mm (0.75 in.) counterbore and a reference measurement (see S55.3) shall be performed. Performance shall conform to S55.21.

**S59. Inspection**

S59.1 *Classification of Inspections*—The inspection requirements specified herein are classified as follows:

- (a) Qualification testing, and
- (b) Quality conformance testing.

S59.2 *Qualification Testing*—Qualification testing shall be performed prior to production. Qualification testing shall be performed on samples which have been produced with equipment and procedures normally used in production. Qualification testing shall consist of the examinations and tests in the order specified in Table S21. Failure of any sensor to meet the requirements of this specification shall be cause for rejection.

TABLE S21 Qualification Testing

Examination and Tests	Requirement	Procedure
Group I: One sample required		
General examination	---	S59.4
Accuracy	S55.1	S58.1
Repeatability	S55.2	S58.2
Sensitivity	S55.4	S58.4
Response time	S55.5	S58.5
Warm-up time	S55.6	S58.6
Steady-state voltage and frequency	S55.7	S58.7
Transient voltage and frequency	S55.8	S58.8
Insulation resistance	S55.9	S58.9
Power interruption	S55.10	S58.10
Short circuit	S55.11	S58.11
Line voltage reversal (dc)	S55.12	S58.12
Temperature	S55.13	S58.13
Enclosure	S55.14	S58.14
Salt spray	S55.15	S58.15
Over-temperature	S55.16	S58.16
Accelerated life	S55.17	S58.17
Vibration	S55.18	S58.18
Shock	S55.19	S58.19
EMI	S55.20	S58.20
Group II: One sample required		
Pressure	S55.21	S58.21

S59.2.1 *Sample Size*—Two fiber optic temperature sensors of each lot shall be subjected to the qualification inspection. An inspection lot shall consist of all sensors of the same classifi-

cation (see C4), produced under essentially the same conditions, in the same facility from the same materials and offered for delivery at the same time. One sample shall be subjected to the tests of Group I. The two samples shall be supplied with the length of cable required for the intended application, but shall not be less than 30.5 m (100 ft). The Group II test requires an additional embedded sensor due to the destructive nature of the test and shall only be accomplished for acquisitions for embedded designs.

S59.3 *Quality Conformance Testing*—Each sensor in each lot offered for delivery shall be subjected to the inspection listed in Table S22 and shall be conducted in the order listed. Failure of any sensor to meet the requirements of this specification shall be cause for rejection.

TABLE S22 Quality Conformance Testing

Examination and Tests	Requirement	Procedure
General examination	---	S59.4
Accuracy	S55.1	S58.1
Repeatability	S55.2	S58.2
Insulation resistance	S55.9	S58.9

S59.4 *General Examination*—Each sensor shall be given a thorough examination to determine conformance to the requirements of this specification with respect to material, finish, workmanship, construction, assembly, dimensions, weight and marking of identification. Examination shall be limited to the examinations that may be performed without disassembling the units. Examination shall also include a check of all adjustments. The manufacturer shall be responsible for ensuring that materials used are manufactured, examined and tested in accordance with the specifications and standards as applicable.

S59.4.1 *Cleaning and Surface Finishes*—Surfaces of castings, forgings, molded parts, stampings, machined and welded parts shall be free of defects such as cracks, porosity, undercuts, voids and gaps as well as sand, dirt, fins, sharp edges, scale, flux, and other harmful or extraneous materials. External surfaces shall be smooth and edges shall be either rounded or beveled. There shall be no burn-through. There shall be no warpage or dimensional change due to heat from welding operation. There shall be no damage to adjacent parts resulting from welding.

S59.5 *Test Conditions*—Unless otherwise specified herein, the fiber optic temperature sensor(s) shall be fully assembled and energized throughout the duration of each test procedure.

Except where the following factors are the variables, the tests shall be conducted with the equipment under the following operating environmental conditions:

- (1) Ambient temperature shall be  $25 \pm 5^{\circ}\text{C}$  ( $77 \pm 9^{\circ}\text{F}$ ), and
- (2) Relative humidity shall be ambient.

## S60. Certification

S60.1 When specified in the purchase order or contract, the purchaser shall be furnished certification that samples representing each lot have been either tested or inspected as directed in this specification and the requirements have been met. When specified in the purchase order or contract, a report of the test result shall be furnished. It is recommended that all test data remain on file for three years at the manufacturer's facility for review by purchaser upon request.

## S61. Product Marking

S61.1 *Opto-electronics Module*—Each opto-electronics module shall be permanently and legibly marked in accordance with the acquisition requirements. The following minimum information shall be provided:

- (1) Nomenclature,
- (2) Design classification,
- (3) National Stock Number (NSN) if available,
- (4) Manufacturer's name and model number,
- (5) Temperature range,
- (6) Contract number, and
- (7) A unique serial number from the manufacturer.

S61.2 *Sensor Head*—Each sensor head shall be permanently and legibly marked in accordance with the acquisition requirements. The following minimum information shall be provided:

- (1) Nomenclature,
- (2) Design classification,
- (3) National Stock Number (NSN) if available,
- (4) Manufacturer's name and model number, and
- (5) A unique serial number from the manufacturer.

*ASTM International takes no position respecting the validity of any patent rights asserted in connection with any item mentioned in this standard. Users of this standard are expressly advised that determination of the validity of any such patent rights, and the risk of infringement of such rights, are entirely their own responsibility.*

*This standard is subject to revision at any time by the responsible technical committee and must be reviewed every five years and if not revised, either reapproved or withdrawn. Your comments are invited either for revision of this standard or for additional standards and should be addressed to ASTM International Headquarters. Your comments will receive careful consideration at a meeting of the responsible technical committee, which you may attend. If you feel that your comments have not received a fair hearing you should make your views known to the ASTM Committee on Standards, at the address shown below.*

*This standard is copyrighted by ASTM International, 100 Barr Harbor Drive, PO Box C700, West Conshohocken, PA 19428-2959, United States. Individual reprints (single or multiple copies) of this standard may be obtained by contacting ASTM at the above address or at 610-832-9585 (phone), 610-832-9555 (fax), or service@astm.org (e-mail); or through the ASTM website (www.astm.org). Permission rights to photocopy the standard may also be secured from the Copyright Clearance Center, 222 Rosewood Drive, Danvers, MA 01923, Tel: (978) 646-2600; http://www.copyright.com/*

S61.2.1 *Embedded Sensor Head*—In addition to the above, the embedded sensor type shall use a removable metal tag which attaches to the cable interface for identification marking. The following notice shall be marked on the opposite side of the tag:

### NOTICE

**Reattach this tag to the cable interface after bearing insulation and keep affixed after the bearing is placed in service.**

S61.3 *Warning Labels*—A visible label shall be affixed to the outside of the opto-electronics module cover and shall contain the following:

### WARNING

**UNTERMINATED OPTICAL CONNECTORS MAY EMIT LASER RADIATION. DO NOT VIEW BEAM WITH OPTICAL INSTRUMENTS AND AVOID DIRECT EXPOSURE TO BEAM.**

A visible label shall be affixed to the sensor head and the inside of the opto-electronics module and shall contain the following:

### WARNING

**INVISIBLE LASER RADIATION. AVOID EXPOSURE TO THE BEAM.**

The labels shall be yellow lettering on a black background.

## S62. Packaging and Package Marking

S62.1 Fiber optic temperature sensors shall be individually packaged and marked in accordance with Section 15.

## S63. Quality Assurance Provisions

S63.1 *Warranty*—Special warranty requirements shall be specified in the acquisition requirements. Otherwise, the standard commercial warranty applies.