



Standard Test Method for Determining Decarburization and Carburization in Hardened and Tempered Threaded Steel Bolts, Screws, Studs, and Nuts (Metric)¹

This standard is issued under the fixed designation F2328M; the number immediately following the designation indicates the year of original adoption or, in the case of revision, the year of last revision. A number in parentheses indicates the year of last reapproval. A superscript epsilon (ϵ) indicates an editorial change since the last revision or reapproval.

1. Scope*

1.1 This test method covers procedures for measuring, classifying, and determining the presence of decarburization and carburization in the threaded section of hardened and tempered metric steel bolts, screws, studs, nuts and similar parts which have been heated to facilitate fabrication or to modify their mechanical properties. This test method is not intended to address products which are intentionally carburized to achieve specific results.

1.2 Two routine methods are described for measuring the limits of and determining the presence of decarburization or carburization; the Optical Method and the Microindentation Method 1. Either method is appropriate for routine examinations. The Microindentation Method 2 shall be considered the referee method.

1.3 For the purpose of these tests, there are five classes of hardened and tempered steel products for which specific measurements must be made with respect to their physical properties.

1.4 The values stated in SI units are to be regarded as standard. No other units of measurement are included in this standard.

1.5 *This standard does not purport to address all of the safety concerns, if any, associated with its use. It is the responsibility of the user of this standard to establish appropriate safety and health practices and determine the applicability of regulatory limitations prior to use.*

2. Referenced Documents

2.1 ASTM Standards:²

¹ This test method is under the jurisdiction of ASTM Committee F16 on Fasteners and is the direct responsibility of Subcommittee F16.01 on Test Methods. Current edition approved Aug. 1, 2014. Published September 2014. Originally approved in 2004. Last previous edition approved in 2014 as F2328M – 07(2014). DOI: 10.1520/F2328M-14.

² For referenced ASTM standards, visit the ASTM website, www.astm.org, or contact ASTM Customer Service at service@astm.org. For *Annual Book of ASTM Standards* volume information, refer to the standard's Document Summary page on the ASTM website.

- [A574M Specification for Alloy Steel Socket-Head Cap Screws \(Metric\)](#)
- [E3 Guide for Preparation of Metallographic Specimens](#)
- [E384 Test Method for Knoop and Vickers Hardness of Materials](#)
- [F835M Specification for Alloy Steel Socket Button and Flat Countersunk Head Cap Screws \(Metric\)](#)
- [F912M Specification for Alloy Steel Socket Set Screws \(Metric\)](#)
- [F1789 Terminology for F16 Mechanical Fasteners](#)

3. Terminology

3.1 Definitions:

3.1.1 *carburization*—process or result of increasing the carbon content of the surface layers of the steel fastener product.

3.1.2 *decarburization*—in accordance with Terminology F1789, is a loss of carbon from the surface layer of the fastener, normally associated with heat treatment.

3.1.3 *gross decarburization*—also known as *complete decarburization*, is characterized by a sufficient carbon loss to show only clearly defined ferrite grains.

3.1.4 *partial decarburization*—characterized as a loss of carbon sufficient to cause a lighter shade of tempered martensite than that of the immediately adjacent base metal, but as being of insufficient carbon loss to show clearly defined ferrite grains.

4. Significance and Use

4.1 Decarburization and carburization are two surface conditions created, either intentionally or unintentionally, as with a pre-existing condition created during the rod rolling process, the rod/wire annealing process, or while heat treating threaded steel products. Too much of either will adversely affect the safety and performance of the threaded product. Therefore, limits have been established for four different product groups: the harder and greater the tensile strength of the product, the more susceptible to failure the product becomes if these limits are exceeded.

*A Summary of Changes section appears at the end of this standard

4.2 When testing to a particular product specification that lists the dimensions and microindentation data to be used, that data shall take precedence over the tables in this test method.

4.3 There are only two viable methods available to detect these deficiencies: either by the visual method or the microindentation method. Both methods are used for routine inspections when evaluations are conducted at a single location on the product sample. Because an evaluation at a specific location may not be representative of the whole part, the referee method employs the microindentation method taken as an average of evaluations conducted on four adjacent threads. This procedure significantly reduces random test variables when compared to testing on a single thread.

4.4 Specifying this test method does not specify or imply that testing shall be for either decarburization or carburization alone or for both conditions. When either test method is performed, both conditions will be apparent and shall be reported. For example, if an order is placed to test for decarburization and none is found but the presence of carburization is detected, it shall be reported on the test report that carburization was found.

5. Class of Decarburization

5.1 *Class Determination*—These measurements by Class are predicated upon their relationship between the height (H) of the external thread at its maximum boundary, disregarding any surface coating, and N, which is the minimum thread height in the non-decarburized zone (see Figs. 1-3). The dimensions for N and H are listed in Table 2 for each Class. Dimension G (Table 1 and Fig. 1) represents the maximum depth of gross or complete decarburization.

NOTE 1—Refer to the product standard for specific requirements. When limits are not specified, use Table 1 as a suggested reference.

6. Preparation

6.1 The use of either the optical or microindentation hardness method requires the finished product to be longitudinally cross-sectioned, approximately through the threaded axis, and mounted for grinding and polishing in any suitable medium which will provide edge retention of the specimen. This shall be performed in accordance with good metallographic practice. See Practice E3.

7. Evaluation by the Optical Method

7.1 Etch the mounted specimen (Section 6) in a 2 to 4 % nital or picral solution to exhibit the microstructure. Examine the specimen at 100X magnification using a method capable of measuring distances to at least 0.001 in. resolution. The width of any light-etching band of martensite defines the depth of decarburization. Compare the image with Fig. 1 for the

maximum limits for G by taking a measurement on a line perpendicular to the flank of the thread midway between the thread crest and root (pitch diameter).

7.2 Interpretation of Results:

7.2.1 Allowable limits for partial decarburization shall be in accordance with 3.1.4 and Fig. 1, and the measured values shall be in accordance with Table 2, when measured in accordance with the illustrations in Figs. 2 and 3.

7.2.2 Allowable limits for gross decarburization (G) shall be in accordance with 3.1.3 and the measured values as defined in Table 1. The optical method is the only valid method for evaluating the depth of gross decarburization. Gross decarburization is prohibited in Class 3 and Class 4 products.

7.2.3 Carburization is identified when the tempered martensite is a darker shade than the immediately adjacent base metal. If visible evidence of surface carburization is present on the surface zone, the microindentation hardness method, in accordance with Section 8, shall be used.

7.2.4 The optical method may not be appropriate for specimens with certain coatings, such as zinc, where the coating can affect the etching process and distort the appearance of the base material microstructure. These coatings shall be removed prior to mounting if the coating prevents proper etching. Care must also be exercised to not alter the surface condition of the substrate during the coating removal process.

7.2.5 If the results of the optical method indicate a possible nonconformance in the measurement of partial decarburization or carburization, or are otherwise inconclusive, the microindentation hardness method (Section 8) shall be performed after the specimens are repolished.

8. Evaluation by the Microindentation Hardness Method

8.1 Prepare the sample in accordance with Section 6 and perform measurements in accordance with Test Method E384 on polished and unetched specimens. Use either a Vickers (136°) indenter or a Knoop indenter with the following load requirements:

Thread Pitch, mm	Load	
	Knoop (HK)	Vickers (HV)
Over 0.60	500 gf	300 gf
0.45 through 0.60	200 gf	200 gf
Less than 0.45	100 gf ^A	100 gf ^A

^A Lighter loads shall be used if the size of the part warrants.

8.2 Routine Decarburization/Carburization Test Method 1—Measurement:

8.2.1 Determine the base metal hardness (Position 1) that is near the intersection of a plane at the thread root diameter and a perpendicular line bisecting the thread crest. Measurement at Position 2 is taken on the same thread crest bisector line from Position 1 to an approximate distance N as determined in Table

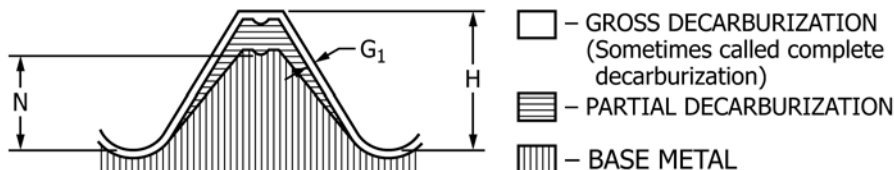
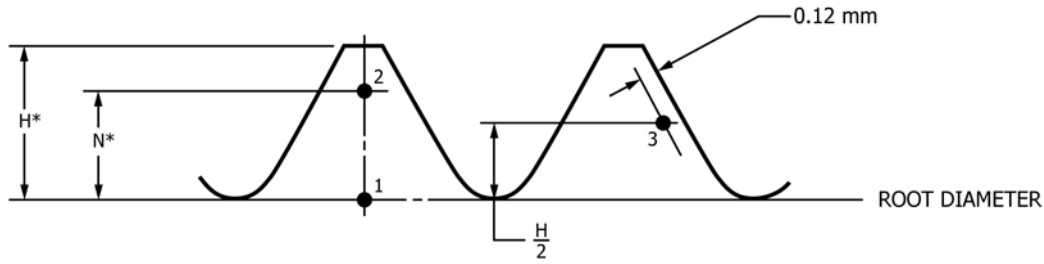

FIG. 1 Decarburization Zones



*See Figure 1

Decarburization // Carburation

FIG. 2 Position for Microindentation Measurements

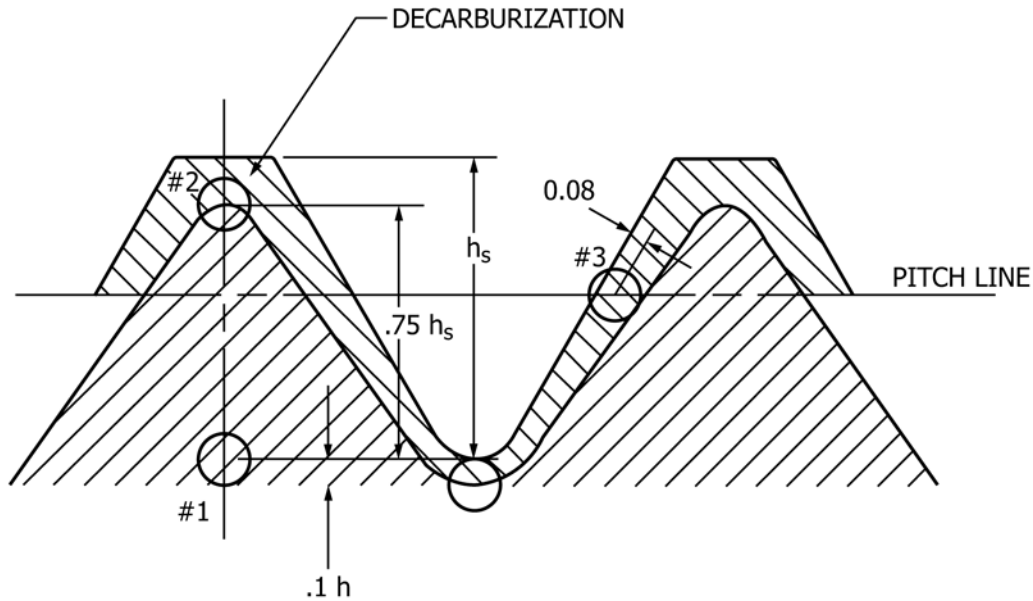

FIG. 3 Microindentation Measurements for Class 3 Products

TABLE 1 Classes of Decarburization: Guide

Class	N	G max	Typical Applications
1	$\frac{1}{2} H$	0.015 mm	For heat treated products which have tensile strengths up to 830 MPa and those with a specified minimum tensile strength of 830 MPa or a hardness range of 24 to 34 HRC, or both.
2	$\frac{2}{3} H$	0.015 mm	For products with a minimum tensile strength of 1040 MPa or a hardness range of 33 to 39 HRC, or both.
3	$\frac{3}{4} H$	none permitted	For products with a minimum tensile strength of 1200 MPa or a minimum specified hardness of 37 HRC, or both.
4	$\frac{3}{4} H$	none permitted	For products with a recessed socket drive of a minimum tensile strength of 980 MPa, a specified hardness range within 38 to 53 HRC or manufactured to the ASTM requirements of Specifications A574M, F835M, or F912M, or both.
5	$\frac{2}{3} H$	0.015 mm	For heat treated nuts with a hardness of 24–38HRC

2 and as specified by the product classification or product specification. See Figs. 2 and 3.

8.2.2 For Class 1 and 2 products, Position 3 hardness shall be measured at a depth of 0.12 mm from the thread flank at an

approximate distance of $H/2$ as measured from the plane of the thread root diameter (Fig. 2).

8.2.3 For Class 3 and Class 4 products, Position 3 hardness shall be measured at an approximate depth of 0.08 mm from the thread flank at an approximate distance of $H/2$, as measured from the plane of the thread root diameter (Fig. 3).

8.2.4 Additionally, Class 4 products shall have a fourth measurement taken in the thread root at a depth of 0.1 h. See Table 2 and Fig. 3.

8.2.5 Position 3 readings and those described in 8.2.4 shall be taken on the same or adjacent thread and at the same time as the readings at positions 1 and 2 using the same hardness scale. The long axis of the Knoop indenter shall be aligned approximately parallel with the thread pitch angle at Position 3.

8.3 Interpretation of Results:

8.3.1 A decrease of more than 30 hardness points of either HK or HV between Position 1 to Position 2 indicates excessive decarburization and that the part does not conform to the specification. If a nonconformance is indicated, proceed to referee test method in 8.4 for verification.

8.3.2 An increase of more than 30 hardness points of either HK or HV between Position 1 to Position 3 shall be regarded

TABLE 2 Decarburization Limits per Classification

NOTE 1—All values shown are in millimetres.

Thread Pitch, P (mm)	Thread Height, H (mm)	Class 1 Hex Head, N (min)	Class 2 Hex Head, N (min)	Class 3 Hex Head, N (min)	Class 4 Skt Head, N (min)	Thread Height H (mm) ^A	0.1 H ^A Root (mm)
0.35	0.202	0.10	0.13	0.15
0.40	0.232	0.12	0.15	0.17
0.45	0.262	0.13	0.17	0.2
0.50	0.307	0.15	0.19	0.22
0.60	0.368	0.18	0.24	0.27
0.70	0.429	0.21	0.28	0.32	0.322	0.429	0.043
0.80	0.491	0.24	0.33	0.37	0.368	0.491	0.049
1.00	0.613	0.30	0.41	0.46	0.460	0.613	0.061
1.25	0.767	0.38	0.51	0.58	0.575	0.767	0.077
1.50	0.920	0.46	0.61	0.69	0.690	0.920	0.092
1.75	1.074	0.54	0.72	0.81	0.806	1.074	0.107
2.00	1.227	0.61	0.82	0.92	0.920	1.227	0.123
2.50	1.534	0.77	1.02	1.15	1.151	1.534	0.153
3.00	1.840	0.92	1.23	1.38	1.380	1.840	0.184
3.50	2.147	1.07	1.43	1.61	1.610	2.147	0.215
4.00	2.454	1.23	1.64	1.84	1.841	2.454	0.245
4.50	2.761	2.071	2.761	0.276
5.00	3.068	2.301	3.068	0.307

^A For Class 4 product only, in reference to Fig. 3.

as excessive carburization and the part does not conform to the specification. If a nonconformance is indicated, proceed to referee test method in 8.5 for verification.

8.4 Decarburization Referee Test Method 2—Measurement:

8.4.1 Determine the base metal hardness as in 8.2.1 by taking the average of all Position 1 and Position 2 readings, as first measured during the routine test, and then on three additional adjacent threads. Determine the condition of the specimen by subtracting the average reading noted at Position 2 from the average reading noted at Position 1, in accordance with 8.3.1.

8.4.2 *Interpretation of Results*—If the average of the four readings indicates a decrease of more than 30 points of either HK or HV from Position 1 to Position 2, the part does not conform to the specification limit.

8.5 Carburization Referee Test Method 2—Measurement:

8.5.1 Determine the base metal hardness as in 8.2.1, 8.2.2, or 8.2.3, as appropriate, by taking the average of all Position 1 and Position 3 readings, as first measured during the routine

test, and then on three additional adjacent threads. Determine the condition of the specimen by subtracting the average reading noted at Position 1 from the average reading noted at Position 3, as defined in 8.3.2. The threaded section will give evidence of carburization if the average of the four readings indicates a positive value.

8.5.2 *Interpretation of Results*—If the average of the four readings indicates an increase of more than 30 points of either HV or HK from Position 1 to Position 3, the part does not conform to the carburization specification limit.

9. Precision and Bias

9.1 Precision and bias evaluations have not been conducted for this test method. When such data is available, a precision and bias section will be added.

10. Keywords

10.1 carburization; complete decarburization; decarburization; gross decarburization; HK; HV; Knoop; microindentation; partial decarburization; tempered martensite; Vickers

SUMMARY OF CHANGES

Committee F16 has identified the location of selected changes to this standard since the last issue (F2328M—07(2014)) that may impact the use of this standard. (Approved August 1, 2014.)

(1) Revised title, scope and Table 1 to cover nuts.

ASTM International takes no position respecting the validity of any patent rights asserted in connection with any item mentioned in this standard. Users of this standard are expressly advised that determination of the validity of any such patent rights, and the risk of infringement of such rights, are entirely their own responsibility.

This standard is subject to revision at any time by the responsible technical committee and must be reviewed every five years and if not revised, either reapproved or withdrawn. Your comments are invited either for revision of this standard or for additional standards and should be addressed to ASTM International Headquarters. Your comments will receive careful consideration at a meeting of the responsible technical committee, which you may attend. If you feel that your comments have not received a fair hearing you should make your views known to the ASTM Committee on Standards, at the address shown below.

This standard is copyrighted by ASTM International, 100 Barr Harbor Drive, PO Box C700, West Conshohocken, PA 19428-2959, United States. Individual reprints (single or multiple copies) of this standard may be obtained by contacting ASTM at the above address or at 610-832-9585 (phone), 610-832-9555 (fax), or service@astm.org (e-mail); or through the ASTM website (www.astm.org). Permission rights to photocopy the standard may also be secured from the Copyright Clearance Center, 222 Rosewood Drive, Danvers, MA 01923, Tel: (978) 646-2600; <http://www.copyright.com/>