



Standard Test Method for Measuring Load Induced Subsidence of Intervertebral Body Fusion Device Under Static Axial Compression¹

This standard is issued under the fixed designation F2267; the number immediately following the designation indicates the year of original adoption or, in the case of revision, the year of last revision. A number in parentheses indicates the year of last reapproval. A superscript epsilon (ϵ) indicates an editorial change since the last revision or reapproval.

1. Scope

1.1 This test method specifies the materials and methods for the axial compressive subsidence testing of non-biologic intervertebral body fusion devices, spinal implants designed to promote arthrodesis at a given spinal motion segment.

1.2 This test method is intended to provide a basis for the mechanical comparison among past, present, and future non-biologic intervertebral body fusion devices. This test method is intended to enable the user to mechanically compare intervertebral body fusion devices and does not purport to provide performance standards for intervertebral body fusion devices.

1.3 This test method describes a static test method by specifying a load type and a specific method of applying this load. This test method is designed to allow for the comparative evaluation of intervertebral body fusion devices.

1.4 Guidelines are established for measuring test block deformation and determining the subsidence of intervertebral body fusion devices.

1.5 Since some intervertebral body fusion devices require the use of additional implants for stabilization, the testing of these types of implants may not be in accordance with the manufacturer's recommended usage.

1.6 *Units*—The values stated in SI units are to be regarded as the standard with the exception of angular measurements, which may be reported in terms of either degrees or radians.

1.7 *The use of this standard may involve the operation of potentially hazardous equipment. This standard does not purport to address all of the safety concerns, if any, associated with its use. It is the responsibility of the user of this standard to establish appropriate safety and health practices and determine the applicability of regulatory limitations prior to use.*

¹ This test method is under the jurisdiction of ASTM Committee F04 on Medical and Surgical Materials and Devices and is the direct responsibility of Subcommittee F04.25 on Spinal Devices.

Current edition approved Dec. 1, 2011. Published January 2012. Originally approved in 2003. Last previous edition approved in 2004 as F2267 – 04. DOI: 10.1520/F2267-04R11.

2. Referenced Documents

2.1 *ASTM Standards*:²

- E4 Practices for Force Verification of Testing Machines
- F1582 Terminology Relating to Spinal Implants
- F1839 Specification for Rigid Polyurethane Foam for Use as a Standard Material for Testing Orthopaedic Devices and Instruments
- F2077 Test Methods For Intervertebral Body Fusion Devices

3. Terminology

3.1 All subsidence testing terminology is consistent with the referenced standards above, unless otherwise stated.

3.2 *Definitions*:

3.2.1 *coordinate system/axes*—three orthogonal axes are defined by Terminology F1582 as seen in Fig. 4. The center of the coordinate system is located at the geometric center of the intervertebral body fusion device assembly. The *X*-axis is along the longitudinal axis of the implant, with positive *X* in the anterior direction, *Y* is lateral, and *Z* is cephalic.

3.2.2 *ideal insertion location*—the implant location with respect to the simulated inferior and superior vertebral bodies (polyurethane) dictated by the type, design, and manufacturer's surgical installation instructions.

3.2.3 *intended method of application*—intervertebral body fusion devices may contain different types of stabilizing features such as threads, spikes, and knurled surfaces. Each type of feature has an intended method of application or attachment to the spine.

3.2.4 *intended spinal location*—the anatomic region of the spine intended for the intervertebral body fusion device. Intervertebral body fusion devices may be designed and developed for specific regions of the spine such as the lumbar, thoracic, and cervical spine. Also, there potentially exist different anatomical surgical approaches, which will result in different implant orientation at different levels of the spine.

² For referenced ASTM standards, visit the ASTM website, www.astm.org, or contact ASTM Customer Service at service@astm.org. For *Annual Book of ASTM Standards* volume information, refer to the standard's Document Summary page on the ASTM website.

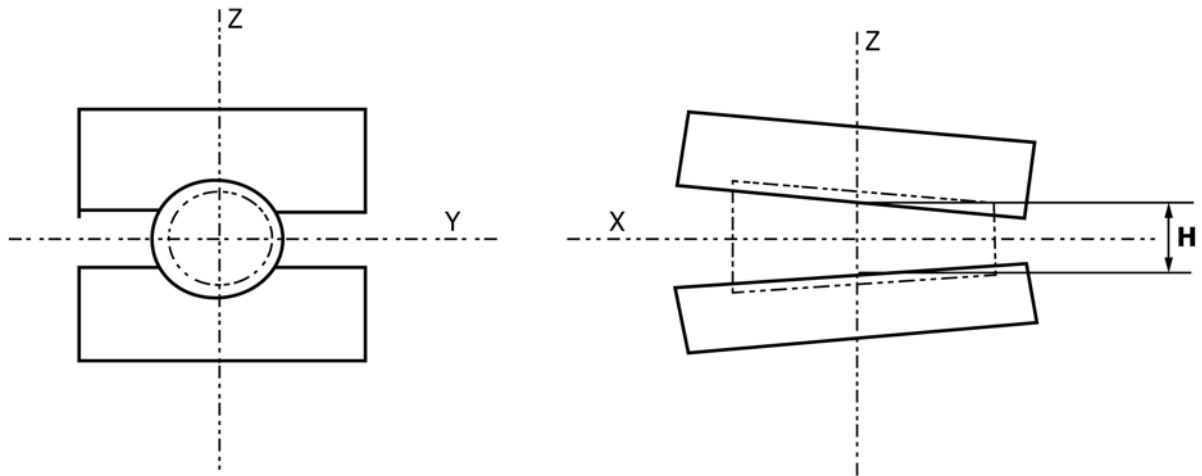

FIG. 1 Intradiscal Height Diagram

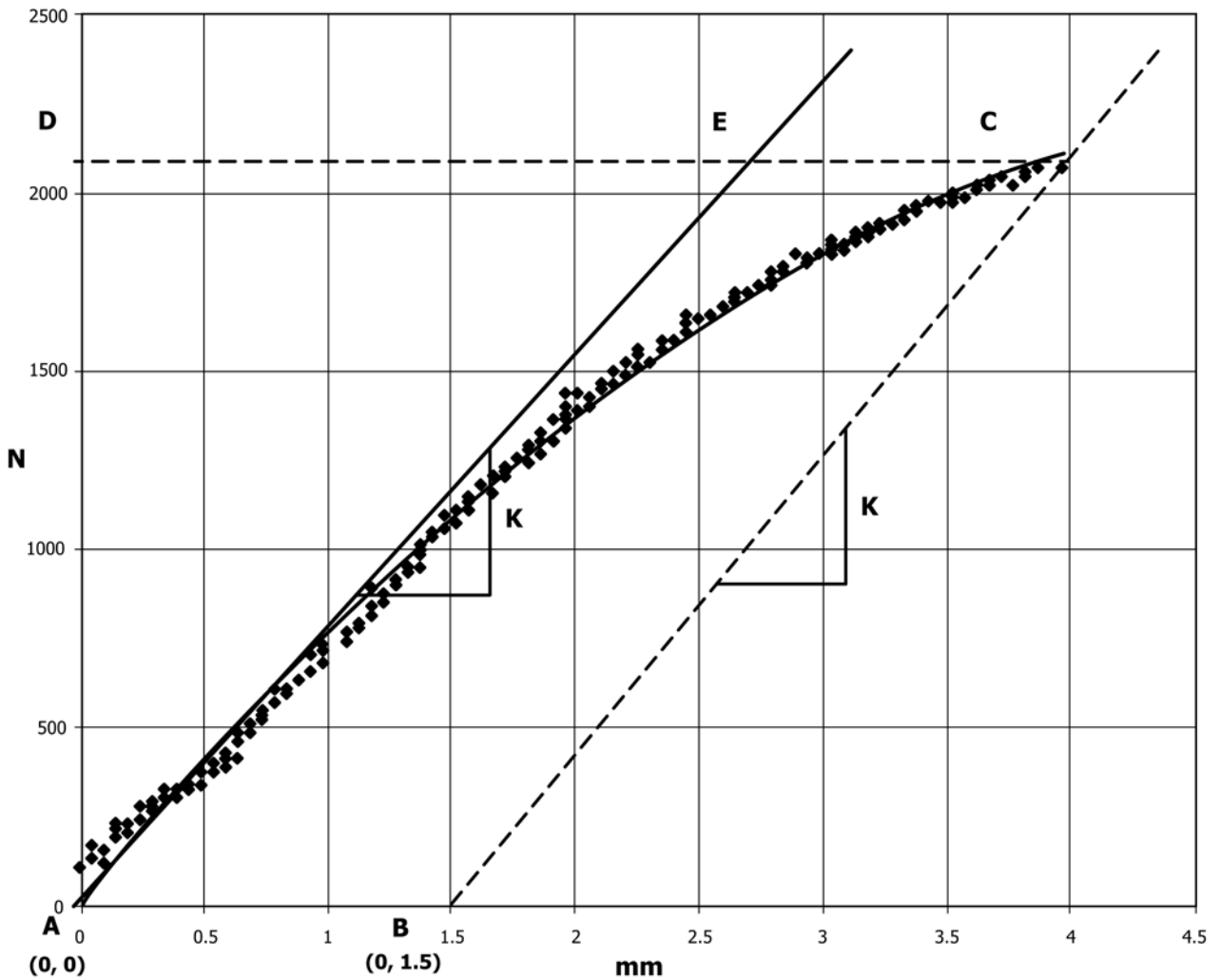

FIG. 2 Typical Load-Displacement Curve with 1.5 mm (Thoracic Device) Offset for Polyurethane Foam Test Blocks

3.2.5 *intervertebral subsidence*—the process of a vertebral body cavitating or sinking around an implanted intervertebral body fusion device resulting in the loss of intradiscal height.

3.2.6 *intradiscal height*—the straight-line distance along the Z-axis between the unaltered simulated vertebral bodies. See Fig. 1.

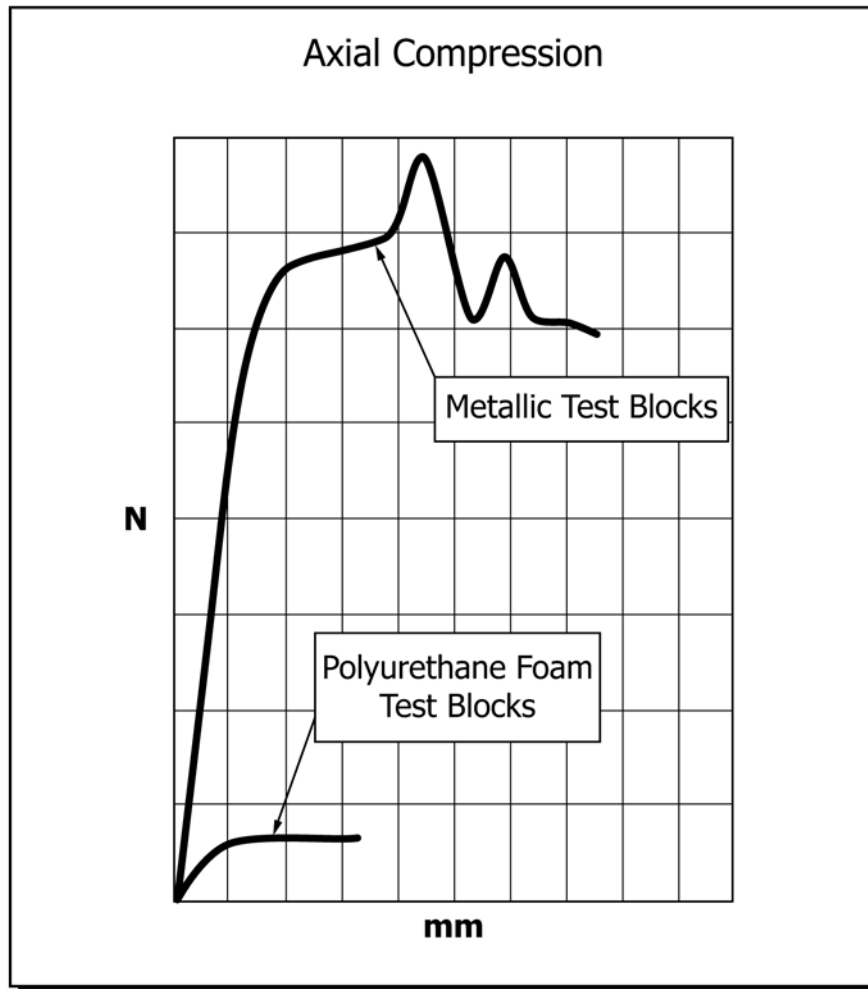

FIG. 3 Typical Load-Displacement Plot Comparison for Test Specimens in Metallic and Polyurethane Test Blocks

3.2.7 *load point*—the point through which the resultant force on the intervertebral device passes (that is, the geometric center of the superior fixture’s sphere) (Fig. 4).

3.2.8 *offset displacement*—offset on the displacement axis equal to 1 mm for cervical disc devices, 1.5 mm for thoracic devices, and 2 mm for lumbar devices (see distance AB in Fig. 2)

3.2.9 *simulated vertebral bodies*—the component of the test apparatus for mounting the intervertebral body fusion device.

3.2.10 *stiffness, (N/mm)*—the slope of the initial linear portion of the load-displacement curve (see the slope of line AE in Fig. 2).

3.2.11 *test block height*—the linear distance along the Z-axis from the top surface of the superior simulated vertebral body to the bottom surface of the inferior simulated vertebral body with the intervertebral body fusion device in position. The block heights shall be 70 mm, 60 mm, and 40 mm for lumbar, thoracic, and cervical intervertebral disc devices respectively. See Fig. 4.

3.2.12 *yield load*—the applied load, F , transmitted by the pushrod (assumed equal to force component parallel to and indicated by load cell), required to produce a permanent

deformation equal to the offset displacement found by plotting line BC with stiffness, K , originating at point B (see Point D in Fig. 2).

4. Summary of Test Method

4.1 To measure load induced subsidence, a test method is proposed for the axial compression of intervertebral body fusion devices specific to the lumbar, thoracic, and cervical spine.

4.2 The axial compressive subsidence testing of the intervertebral body fusion device will be conducted in a simulated motion segment via a gap between two polyurethane foam blocks.

4.3 Grade 15 foam shall be employed conforming to Specification F1839.

5. Significance and Use

5.1 Intervertebral body fusion devices are generally simple geometric shaped devices, which are often porous or hollow in nature. Their function is to support the anterior column of the spine to facilitate arthrodesis of the motion segment.

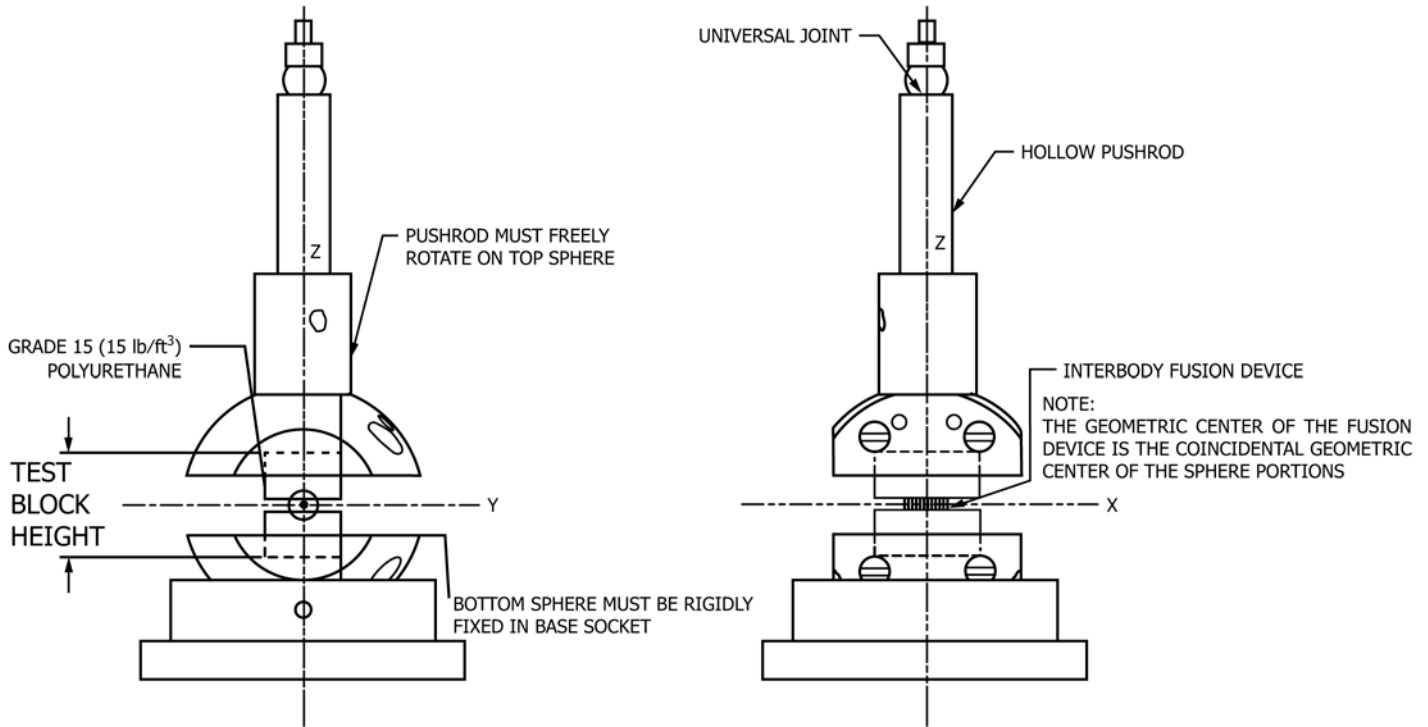

FIG. 4 Subsidence Test Fixture

5.2 This test method is designed to quantify the subsidence characteristics of different designs of intervertebral body fusion devices since this is a potential clinical failure mode. These tests are conducted *in vitro* in order to simplify the comparison of simulated vertebral body subsidence induced by the intervertebral body fusion devices.

5.3 The static axial compressive loads that will be applied to the intervertebral body fusion devices and test blocks will differ from the complex loading seen *in vivo*, and therefore, the results from this test method may not be used to directly predict *in vivo* performance. The results, however, can be used to compare the varying degrees of subsidence between different intervertebral body fusion device designs for a given density of simulated bone.

5.4 The location within the simulated vertebral bodies and position of the intervertebral body fusion device with respect to the loading axis will be dependent upon the design and manufacturer's recommendation for implant placement.

6. Apparatus

6.1 Test machines will conform to the requirements of Practices E4.

6.2 The intradiscal height, H , (Fig. 1) shall be determined from vertebral body and disc morphometric data at the intended level of application. Suggested heights are as follows: 10 mm for the lumbar spine, 6 mm for the thoracic spine and 4 mm for the cervical spine. The user of this test method should select the intradiscal height that is appropriate for the device being tested.

6.3 *Axial Compressive Testing Apparatus*—An example axial compressive test fixture can be referenced in Figs. 4 and

5. Two pieces of polyurethane foam or rigid metal are rigidly mounted inside the test fixture. The actuator of the testing machine is connected to the pushrod by a minimal friction ball and socket joint or universal joint (that is, unconstrained in bending). The pushrod is connected to the superior fixture by a minimal friction sphere joint (that is, unconstrained in bending and torsion). The inferior sphere portion firmly holds the inferior polyurethane block and is rigidly fixed within the base socket so that no rotation occurs. The hollow pushrod and superior sphere should be of minimal weight so as to be considered a “two force” member. It thus applies to the intervertebral device a resultant force directed along the pushrod's axes and located at the center of the superior fixture's sphere joint (the geometric center of the device being tested). The polyurethane blocks are to have surfaces that mate geometrically with the intervertebral device similar to how the device is intended to mate with vertebral end plates. The test apparatus will be assembled such that the Z-axis of the intervertebral device is initially coincident with the pushrod's axis and collinear with the axis of the testing machine's actuator and load cell. The length of the pushrod between the center of the ball-and-socket joint to the center of the spherical surface is to be a minimum of 38 cm. This is required to minimize deviation of the pushrod's axis (direction of applied force, F) from that of the test machine's load cell axis. In other words, this is to minimize the error in using and reporting that the force indicated by the load cell F_{ind} is the applied load, F , and is equal to the compressive force, F_z , on the intervertebral body fusion device. For example, a 1 mm displacement of the spherical surfaces center in the XY plane would produce an angle between axes of 0.15° , (10 mm producing 1.5°). Figs. 4 and 5 are schematics of this test set up.

AXIAL COMPRESSIVE LOADING POINT

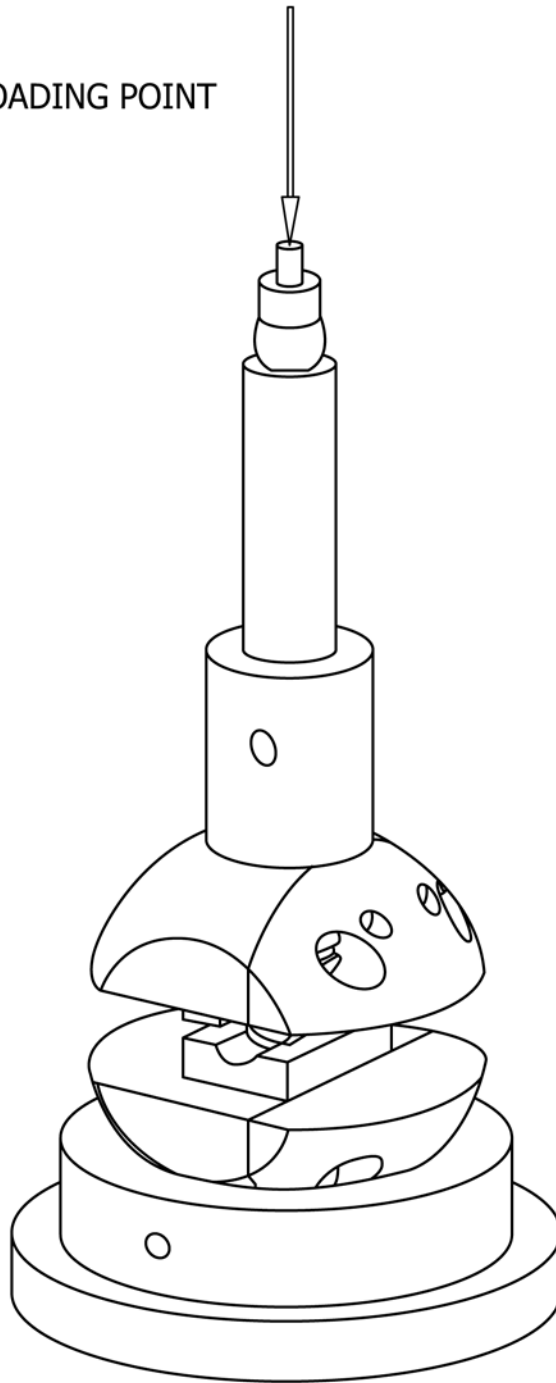

FIG. 5 Subsidence Test Fixture

7. Sampling

7.1 Implants may be retested provided that the tested device has undergone a microscopic and geometric examination with no damage or permanent deformation detected.

7.2 Each pair of polyurethane foam blocks shall be used for one test only.

7.3 The test assemblies (that is, intervertebral body fusion device and polyurethane blocks) shall be labeled and shall be maintained according to good laboratory practice. The test assembly can be disassembled to facilitate examination of surface conditions.

7.4 All tests shall have a minimum of five test samples.

7.5 All implants should be prepared in the manner in which they would normally be used clinically.

8. Procedure for Static Axial Compression Test

8.1 Two different testing conditions shall be used:

8.1.1 Rigid metallic blocks shall be used to determine the stiffness of the device being tested.

8.1.2 Polyurethane blocks will be used to determine the device's propensity to subside.

8.2 The intervertebral body fusion devices are to be inserted into two prepared rigid metallic blocks following the manufacturer's suggested protocol for insertion of the implant (that is, the geometry of the implant configuration shall match that of *in vivo* conditions). The initial intradiscal height, *H*, (Fig. 1) shall be constant for all tests for a given intervertebral body fusion device.

8.3 The stiffness of the device shall be determined according to Test Methods F2077. (Note that five new devices will be used for the subsidence test since Test Methods F2077 is a destructive test.)

8.4 The intervertebral body fusion devices are also to be inserted into two prepared polyurethane blocks following the manufacturer's suggested protocol for insertion of the implant (that is, the geometry of the implant configuration shall match that of *in vivo* conditions). The initial intradiscal height, *H*, (Fig. 1) shall be constant for all tests for a given intervertebral body fusion device.

8.5 The load is to be applied to the intervertebral body fusion devices on coordinates (0, 0, *Z*) as described in 6.3 at a rate of 0.1 mm/s.

8.6 The load-displacement curves shall be recorded. The yield load (N), and stiffness (N/mm) for both testing conditions (see 8.1.1 and 8.1.2) are to be established. Fig. 3 shows representative load-displacement curves for both testing conditions.

8.7 By modeling the subsidence testing systems as two springs in series, one can derive the relationship between the stiffness of the intervertebral body fusion device and the stiffness of the polyurethane foam blocks (simulated vertebral bodies). The equation for K_p , the polyurethane foam test block stiffness, is as follows:

$$K_p = \frac{K_s K_d}{K_d - K_s} \quad (1)$$

where:

K_d = stiffness of the intervertebral body fusion device (section 8.3), and

K_s = stiffness of the system (sections 8.4 – 8.6).

8.8 Stiffness values for k_d , k_s as well as the value of K_p (N/mm) shall be recorded for each intervertebral body fusion device, and an average stiffness value for k_d , k_s , and K_p (N/mm) shall be established for each intervertebral body fusion device. From Test Methods F2077, the average stiffness value of the device, k_d , shall also be recorded.

9. Report

9.1 The report should specify the intervertebral body fusion device assembly components, the intervertebral body fusion device assembly, the intended spinal location, and the numbers of specimens tested. Any pertinent information about the components such as name, design, manufacturer, material, the part number, lot number, size, and so forth shall be stated. All information necessary to reproduce the assembly shall also be included. Prior usage of any specimen shall be documented.

9.2 Exact loading configurations for the testing apparatus shall be included. All deviations from the recommended test procedures shall be reported, and all relevant testing parameters must be stated.

9.3 The report of this mechanical testing shall include a complete description of all failures, modes of failure and deformation of the test block assembly or test apparatus. The mechanical test report shall include all load-displacement curves for both axial compression protocols delineated in this test method. A typical load-displacement curve for the intervertebral body fusion device tested with metallic blocks and in the polyurethane foam can be seen in Fig. 3. All data for stiffness (k_p , k_d , and k_s), yield load, including the mean and standard deviation will be reported for each intervertebral body fusion device testing configuration.

10. Precision and Bias

10.1 *Precision*—Data establishing the precision of this test method have not yet been obtained.

10.2 *Bias*—No statement can be made as to bias of this test method since no acceptable reference values are available, nor can they be obtained because of the destructive nature of the tests.

11. Keywords

11.1 intervertebral body fusion device; spinal implants; subsidence and static axial compression

APPENDIX**(Nonmandatory Information)****X1. RATIONALE**

X1.1 Intervertebral body fusion devices are manufactured in a variety of sizes materials and shapes with various design features. The purpose of this test method is to allow for a consistent, repeatable comparison of different intervertebral body fusion device assemblies in this specific loading mode.

X1.2 All of the spinal implants which fall into the category of intervertebral body fusion devices are intended for the purpose of arthrodesis, and therefore, all of the implants will reside in the disc space with varied orientations and methods of fixation to the adjacent vertebral bodies. This test method will allow for comparison of these devices since the methods and loading configuration remains consistent regardless of method of application.

X1.3 The proposed test configuration is based on anatomical dimensions and provides for the least material condition (for example, one unilateral implant).

X1.4 The stiffness of the polyurethane foam, kp , as calculated in this test method is an indicator of the propensity of an intervertebral body fusion device to subside or migrate into the endplates of the vertebral bodies. A low value of kp indicates a greater propensity for the device to subside into the vertebral bodies and a high value indicates a lower propensity for the device to subside into the vertebral bodies.

X1.5 Test Methods **F2077** sets forth methods for determining the stiffness of the intervertebral body fusion device, however, since the method of Test Methods **F2077** utilizes steel testing blocks, the user can not gage the response of the intervertebral body fusion device when placed against vertebral

bodies, which are most likely at least an order of magnitude less stiff than that of the device itself. This test method provides a method for determining the device's propensity to subside into the endplates of the vertebral bodies by testing the device in simulated vertebral bodies, grade 15 polyurethane foam. The collective stiffness of this assembly is denoted by ks . In a limiting case, as the stiffness of the intervertebral body fusion device approaches that of the grade 15 foam, the stiffness of the assembly would be greatly influenced by the stiffness of both the device and the stiffness of the polyurethane foam with no method for determining the relative contribution of each component to ks . To alleviate this issue, this test method effectively considers the contribution of the stiffness of the device itself by modeling the system as two springs in series, thus leaving the user with the stiffness of the polyurethane foam. This calculated theoretical value serves as a benchmark to compare various devices and their propensity to subside into the endplates. As an example, if one calculates two kp values for two different intervertebral body fusion devices, the lower of the two values of kp will, for a given spinal axial force across the endplates, result in a larger displacement of the vertebral body. In other words, the device with the lower kp will subside a greater distance into the vertebral bodies as compared to the other device with a higher kp .

X1.6 The purpose of this test method is to allow for the comparison of different intervertebral body fusion devices and does not attempt to dictate performance standards for these types of devices since *in vivo* spinal loading is very complex, highly variable, and not yet fully understood.

ASTM International takes no position respecting the validity of any patent rights asserted in connection with any item mentioned in this standard. Users of this standard are expressly advised that determination of the validity of any such patent rights, and the risk of infringement of such rights, are entirely their own responsibility.

This standard is subject to revision at any time by the responsible technical committee and must be reviewed every five years and if not revised, either reapproved or withdrawn. Your comments are invited either for revision of this standard or for additional standards and should be addressed to ASTM International Headquarters. Your comments will receive careful consideration at a meeting of the responsible technical committee, which you may attend. If you feel that your comments have not received a fair hearing you should make your views known to the ASTM Committee on Standards, at the address shown below.

This standard is copyrighted by ASTM International, 100 Barr Harbor Drive, PO Box C700, West Conshohocken, PA 19428-2959, United States. Individual reprints (single or multiple copies) of this standard may be obtained by contacting ASTM at the above address or at 610-832-9585 (phone), 610-832-9555 (fax), or service@astm.org (e-mail); or through the ASTM website (www.astm.org). Permission rights to photocopy the standard may also be secured from the Copyright Clearance Center, 222 Rosewood Drive, Danvers, MA 01923, Tel: (978) 646-2600; <http://www.copyright.com/>