



# Standard Specification for Headforms<sup>1</sup>

This standard is issued under the fixed designation F2220; the number immediately following the designation indicates the year of original adoption or, in the case of revision, the year of last revision. A number in parentheses indicates the year of last reapproval. A superscript epsilon ( $\epsilon$ ) indicates an editorial change since the last revision or reapproval.

## INTRODUCTION

This specification identifies the headforms used for testing protective headgear in individual ASTM International test methods and performance standards (standard specifications). This specification was closely based on ISO DIS 6220, which was never published as an International Standard and is no longer available. EN 960, a published standard, is also based on ISO DIS 6220 and has been used as a basis for this standard.

### 1. Scope

1.1 This standard specifies the materials, sizing, and manufacturing details of test headforms for use in the testing of protective headgear. Details of the exterior dimension of the headforms are included.

1.2 The values stated in SI units are to be regarded as standard. No other units of measurement are included in this standard.

### 2. Referenced Documents

#### 2.1 ASTM Standards:<sup>2</sup>

[B92/B92M Specification for Unalloyed Magnesium Ingot and Stick For Remelting](#)

#### 2.2 Other Standards:

[EN 960 Headforms for Use in the Testing of Protective Helmets](#)

### 3. Terminology

#### 3.1 Definitions:

3.1.1 *basic plane, n*—an anatomical plane that includes the superior rim of the external auditory meatus (upper edge of the external openings of the ear) and the inferior margin of the orbit (the lowest point of the floor of the eye socket) (see [Figs. 1 and 2](#)).

3.1.2 *coronal plane, n*—an anatomical plane perpendicular to both the basic and midsagittal planes and passing through

the superior rims of the right and left external auditory meatuses. The transverse plane corresponds to the coronal plane (see [Figs. 1 and 2](#)).

3.1.3 *impact headforms, n*—headforms used for impact testing of protective headgear. Impact headforms shall conform to the external dimension defined in this specification. These headforms shall meet the material, dimensions, mass, and center of gravity requirements of this specification. These headforms shall include surface markings corresponding to the basic, coronal, midsagittal, and reference planes.

3.1.4 *midsagittal plane, n*—an anatomical plane perpendicular to the basic plane and containing the midpoint of the line connecting the notches of the right and left inferior orbital ridges and the midpoint of the line connecting the superior rims of the right and left external auditory meatuses (see [Figs. 1 and 2](#)).

3.1.5 *other (reference) headforms, n*—headforms used for other testing, other than impact, of protective headgear. They shall conform to the external dimension requirements of each particular headform size, as specified in this specification. Reference headforms shall be made of material of sufficient strength and stiffness to maintain their geometry during testing. Full-chin headforms will be used as necessary. Reference headforms shall include surface markings corresponding to the basic, coronal, midsagittal, and reference planes.

3.1.6 *reference plane, n*—a plane marked on the headforms at a specified distance above and parallel to the basic plane (see [Fig. 2](#)).

### 4. Classification

4.1 This specification identifies the requirements for six test headform sizes: F2220-A, F2220-C, F2220-E, F2220-J, F2220-M, and F2220-O.

<sup>1</sup> This specification is under the jurisdiction of ASTM Committee F08 on Sports Equipment, Playing Surfaces, and Facilities and is the direct responsibility of Subcommittee F08.53 on Headgear and Helmets.

Current edition approved June 1, 2015. Published August 2015. Originally approved in 2002. Last previous edition approved in 2014 as F2220 – 14. DOI: 10.1520/F2220-15.

<sup>2</sup> For referenced ASTM standards, visit the ASTM website, [www.astm.org](http://www.astm.org), or contact ASTM Customer Service at [service@astm.org](mailto:service@astm.org). For *Annual Book of ASTM Standards* volume information, refer to the standard's Document Summary page on the ASTM website.

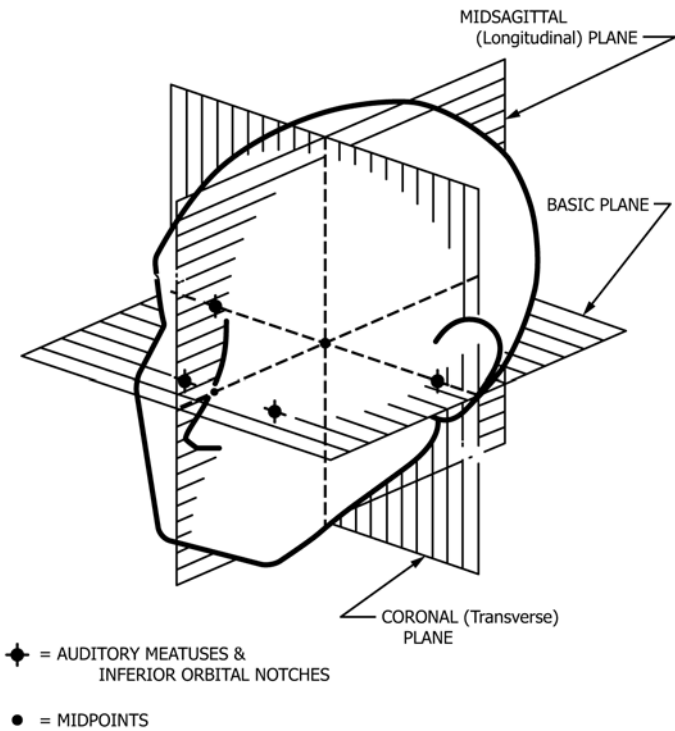

FIG. 1 Anatomical Planes

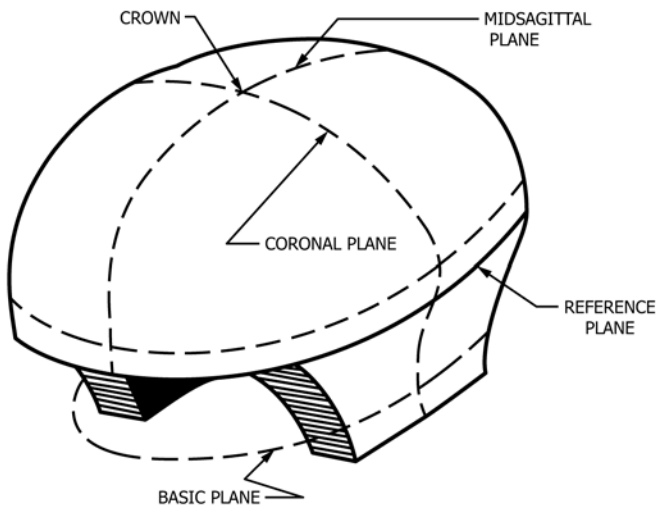

FIG. 2 Impact Headform—Basic, Reference, Midsagittal Planes

5. Dimensions

5.1 *Datum Levels*—All datum levels are quoted relative to the reference plane (“0” level) and are given in mm.

5.2 *Dimensions*—The external dimensions that the headforms must conform to are identified in Annex A1. The segment lengths from the intersection of the coronal plane, midsagittal plane and the reference plane of the test headform to the intersection of a horizontal angle and a point at each datum level above the reference plane are given. The exact geometry of the external surface may be determined by a spline function or other curve fitting algorithm in order to produce a smooth and continuous outer headform surface. The headforms shall be symmetrical about the midsagittal plane. Internal geometry may be defined to satisfy the requirements of the individual test specifications. The resulting headform must still comply with the other requirements of this specification.

6. Impact Headforms

6.1 *Materials and Manufacture*—The impact headforms shall be made of K1A-F magnesium (nominal composition 0.7% Zr, balance Mg; Specification B92/B92M, Grade 9980A).

6.2 *Performance Requirements*—The impact headforms shall not have resonant frequencies below 2000 Hz.

6.3 *Mass*—The total mass of the drop assembly (including the instrumented headform and supporting assembly) shall be described in the specific test method for evaluating protective headgear. The mass of the impact headform may be adjusted to accommodate the specific test method requirements.

6.4 *Center of Gravity*—The center of gravity of the impact headform shall lie at a point on the central vertical axis, 12.7 mm above the reference plane.

6.5 *Product Marking*—All impact headforms shall be marked with:

- 6.5.1 Headform size;
- 6.5.2 Basic plane;
- 6.5.3 Reference plane; and
- 6.5.4 Midsagittal (longitudinal) and coronal (transverse) planes through the vertical axis.

7. Other (Reference) Headforms

7.1 *Materials and Manufacture*—Other headforms shall be made of material of sufficient strength and stiffness to maintain their geometry during testing.

8. Keywords

- 8.1 headform(s); helmet(s); protective headgear

(Mandatory Information)

A1. HEADFORM DATA

A1.1 Headform Data Above and Below the Reference Plane

A1.1.1 See Fig. A1.1 and Tables A1.1-A1.6.

A1.2 Headform Data from Above the Reference Plane, Top View

A1.2.1 See Fig. A1.2.

A1.3 Headform Data from Below the Reference Plane, Bottom View

A1.3.1 See Fig. A1.3.

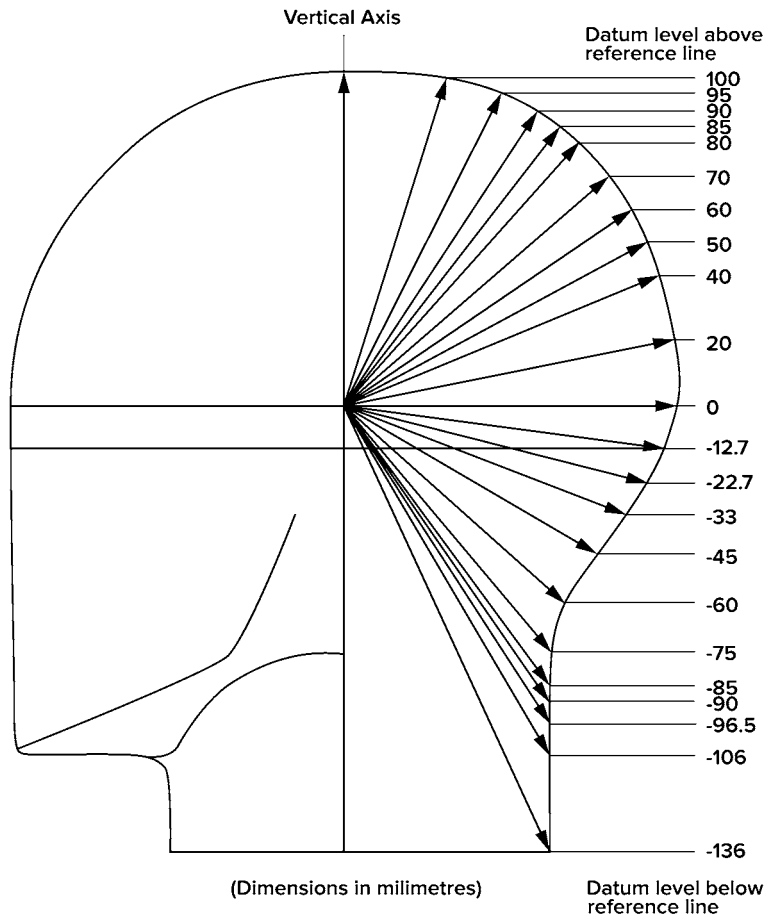

FIG. A1.1 Headform Datum Levels Above and Below the Reference Plane (see Tables A1.1-A1.6 for specific datum levels)

**TABLE A1.1 External Dimensions for Full Headform Size F2220-A**

NOTE 1—Angles in degrees with a tolerance of  $\pm 0.5^\circ$ . Radii in millimetres, with a tolerance of  $\pm 1.0\%$ . Datum levels with a tolerance of  $\pm 0.5$  mm.

NOTE 2—The full size headform shall have a jaw line which resembles the human jaw. This jaw line should be radiused along its length to eliminate any sharp edges. The base of the neck shall be squared off perpendicular to the central vertical axis.

NOTE 3—Those data points which form the chin of the headform are permitted to exceed the published tolerance once a radius has been applied.

F2220 - A	Angle													
	0° Front	15°	30°	45°	60°	75°	90°	105°	120°	135°	150°	165°	180° Rear	
Height	85	88.2	88.1	88.0	87.9	87.9	88.0	88.2	88.7	89.7	91.3	92.5	93.0	92.7
Above	80	88.2	88.3	88.4	88.0	87.2	86.8	86.9	87.7	89.2	91.4	93.5	93.4	93.2
Reference	70	89.8	90.0	89.9	88.0	85.7	84.6	84.5	85.8	87.9	90.6	93.1	93.2	93.1
Plane	60	90.6	90.6	90.2	86.7	83.5	81.8	81.7	83.3	86.1	89.3	92.3	92.6	92.5
(mm)	50	90.1	90.1	89.5	84.7	80.9	78.7	78.5	80.5	83.7	87.5	91.0	91.8	91.6
	40	89.1	89.0	88.2	82.4	78.1	76.0	75.6	77.7	81.2	85.6	89.5	90.9	90.7
	20	87.7	86.8	84.9	78.0	72.8	70.1	69.7	72.5	76.3	81.2	86.2	88.9	89.0
Reference	0	88.0	86.5	83.0	75.5	70.0	67.0	66.5	69.5	73.5	78.5	84.0	87.0	88.0
Plane														
	-11.1	88.7	87.2	83.2	75.3	69.4	66.9	66.9	69.4	72.9	77.8	82.3	85.2	85.7
	-19.9	90.2	90.2	84.9	76.6	69.4	66.1	64.6	67.5	70.4	75.2	79.5	82.4	82.9
	-30.6	93.2	94.6	86.6	77.8	71.8	69.1	63.8	65.6	68.7	73.2	77.3	79.6	80.1
Depth	-39.4	96.4	97.8	88.3	79.9	74.3	71.8	66.8	67.7	70.1	73.0	76.0	78.2	77.7
Below	-52.5	102.5	103.8	93.2	85.1	80.1	75.3	73.5	73.9	75.0	77.1	79.0	79.7	78.6
Reference	-65.6	109.8	111.0	100.0	92.3	87.9	84.0	82.8	83.1	83.4	84.0	84.3	85.0	85.3
Plane	-74.4	115.2	116.4	104.6	97.2	94.3	90.2	89.9	90.2	90.5	91.1	91.3	91.9	92.2
(mm)	-78.8	118.1	119.2	106.4	100.6	93.1	93.3	93.6	93.9	94.1	94.7	95.0	95.5	95.8
	-84.4	121.9	123.0	109.3	96.8	97.8	98.1	98.4	98.6	98.9	99.4	99.7	100.2	100.5
	-92.8	127.9	128.9	104.3	104.3	105.2	105.4	105.7	105.9	106.1	106.6	106.9	107.4	107.6
	-119.0	127.9	127.9	128.1	128.1	128.9	129.1	129.3	129.5	129.7	130.1	130.3	130.7	130.9

Distance from reference plane to top of headform: 89.7 mm

Depth to basic plane: -24.0 mm

**TABLE A1.2 External Dimensions for Full Headform Size F2220-C**

NOTE 1—Angles in degrees with a tolerance of  $\pm 0.5^\circ$ . Radii in millimetres, with a tolerance of  $\pm 1.0\%$ . Datum levels with a tolerance of  $\pm 0.5$  mm.

NOTE 2—The full size headform shall have a jaw line which resembles the human jaw. This jaw line should be radiused along its length to eliminate any sharp edges. The base of the neck shall be squared off perpendicular to the central vertical axis.

NOTE 3—Those data points which form the chin of the headform are permitted to exceed the published tolerance once a radius has been applied.

F2220 - C	Angle													
	0° Front	15°	30°	45°	60°	75°	90°	105°	120°	135°	150°	165°	180° Rear	
Height	90	92.3	92.2	92.0	91.9	91.9	91.9	92.1	92.5	93.2	94.1	94.9	95.2	95.1
Above	85	92.1	92.0	91.8	91.4	90.9	90.7	90.9	91.7	93.0	94.8	96.2	96.4	96.3
Reference	80	92.4	92.4	92.3	91.4	90.2	89.7	89.9	90.9	92.6	95.0	96.6	96.9	96.9
Plane	70	93.8	93.5	93.1	91.0	88.5	87.4	87.6	88.9	91.3	94.3	96.3	96.9	96.9
(mm)	60	94.2	93.7	93.0	89.8	86.3	84.6	84.6	86.3	89.3	92.8	95.3	96.2	96.3
	50	93.8	93.1	92.2	87.9	83.6	81.5	81.4	83.5	86.9	90.8	93.9	95.1	95.5
	40	93.1	92.1	90.8	85.7	80.7	78.6	78.6	80.7	84.2	88.7	92.4	94.1	94.9
	20	91.8	90.1	87.8	81.5	75.4	72.9	72.4	75.4	79.6	84.5	89.1	91.9	92.7
Reference	0	91.5	89.5	86.0	79.0	72.5	70.0	69.5	72.5	77.0	82.0	87.5	90.5	91.5
Plane														
	-11.5	92.2	90.2	86.3	77.9	71.9	69.5	69.5	71.9	75.4	80.8	85.3	88.3	88.7
	-20.6	93.8	93.3	87.9	79.2	72.0	68.7	67.2	69.6	73.0	78.3	82.6	85.5	86.0
	-31.8	96.9	97.8	89.8	80.5	74.2	71.9	66.1	68.3	71.5	76.0	80.1	82.4	82.8
Depth	-40.8	100.2	101.1	91.1	82.3	77.2	74.2	69.3	70.1	72.6	75.9	78.9	81.0	80.6
Below	-54.4	106.5	107.3	96.7	88.3	82.9	78.1	76.3	76.7	77.7	79.9	81.7	82.5	81.7
Reference	-68	114.0	114.8	103.5	95.5	91.4	87.1	85.6	86.2	87.8	87.1	87.5	88.1	88.4
Plane	-77.1	119.7	120.4	108.3	100.8	97.7	93.3	93.0	93.6	93.8	94.4	94.7	95.3	95.6
(mm)	-81.7	122.7	123.4	110.2	102.9	96.3	96.6	96.8	97.4	97.7	98.2	98.5	99.0	99.3
	-87.6	126.7	127.4	113.4	100.6	101.4	101.6	101.9	102.4	102.5	103.1	103.4	104.0	104.1
	-96.2	132.8	133.5	108.0	108.2	108.9	109.1	109.4	109.8	110.0	110.5	110.8	111.3	111.4
	-123.4	132.6	132.6	132.8	133.0	133.5	133.7	133.9	134.3	134.4	134.9	135.1	135.5	135.6

Distance from reference plane to top of headform: 93.0 mm

Depth to basic plane: -25.0 mm

**TABLE A1.3 External Dimensions for Full Headform Size F2220-E**

NOTE 1—Angles in degrees with a tolerance of  $\pm 0.5^\circ$ . Radii in millimetres, with a tolerance of  $\pm 1.0\%$ . Datum levels with a tolerance of  $\pm 0.5$  mm.

NOTE 2—The full size headform shall have a jaw line which resembles the human jaw. This jaw line should be radiused along its length to eliminate any sharp edges. The base of the neck shall be squared off perpendicular to the central vertical axis.

NOTE 3—Those data points which form the chin of the headform are permitted to exceed the published tolerance once a radius has been applied.

F2220 - E	Angle													
	0° Front	15°	30°	45°	60°	75°	90°	105°	120°	135°	150°	165°	180° Rear	
Height Above Reference Plane (mm)	95	95.5	95.5	95.5	95.5	95.5	95.6	95.7	95.9	96.1	96.3	96.4	96.4	96.4
	90	94.4	94.4	94.3	94.3	94.4	94.5	94.7	95.2	96.1	97.5	98.8	99.2	99.1
	85	94.5	94.6	94.7	94.4	93.7	93.5	93.7	94.4	95.6	97.7	99.5	99.9	99.8
	80	95.3	95.4	95.5	94.5	93.1	92.5	92.7	93.7	95.1	97.6	99.7	100.1	100.0
	70	96.8	97.0	96.4	94.2	91.5	90.2	90.2	91.5	93.7	96.8	99.5	100.0	99.8
	60	97.1	97.3	96.2	92.9	89.4	87.4	87.3	89.0	91.8	95.3	98.7	99.2	99.1
	50	96.5	96.8	95.3	91.0	86.8	84.4	84.2	86.2	89.4	93.4	97.5	98.2	98.2
40	95.7	95.8	93.9	88.8	84.2	81.3	81.6	83.8	86.9	91.4	96.3	97.3	97.3	
20	94.5	93.6	91.2	84.6	79.1	76.2	76.0	78.7	82.5	87.4	92.8	95.3	95.7	
Reference Plane	0	94.5	93.0	90.0	82.0	76.5	73.5	73.0	76.0	80.0	85.0	91.0	94.0	94.5
Depth Below Reference Plane (mm)	-11.9	95.2	93.8	89.3	80.4	74.0	71.5	71.5	74.0	77.9	83.4	87.8	91.3	91.8
	-21.3	96.9	96.4	91.0	82.3	74.1	70.8	69.4	72.2	75.1	80.4	85.2	88.1	88.6
	-32.8	100.0	101.0	92.5	83.2	76.9	74.1	68.4	70.6	73.7	78.2	82.8	85.1	85.5
	-42.1	103.5	104.4	94.4	85.1	79.6	76.6	71.3	72.5	74.9	78.3	81.7	83.4	83.0
	-56.2	109.9	110.8	99.8	90.9	85.5	80.4	79.0	79.0	80.0	82.6	84.4	85.2	84.4
	-70.2	117.7	118.5	106.8	98.8	94.0	89.8	88.6	89.2	89.5	89.8	90.1	90.7	91.1
	-79.6	123.6	124.3	111.8	104.0	100.9	96.5	96.2	96.8	97.0	97.3	97.6	98.2	98.5
	-84.3	126.6	127.4	113.8	106.1	99.6	99.8	100.1	100.7	100.9	101.2	101.5	102.0	102.3
	-90.4	130.8	131.5	117.1	103.8	104.8	105.0	105.3	105.8	106.1	106.3	106.6	107.1	107.4
	-99.3	137.1	137.8	111.4	111.6	112.6	112.8	113.0	113.5	113.8	114.0	114.2	114.7	115.0
-127.4	136.9	136.9	137.0	137.2	138.0	138.2	138.4	138.8	139.0	139.2	139.4	139.8	140.0	

Distance from reference plane to top of headform: 96.0 mm

Depth to basic plane: -26.0 mm

**TABLE A1.4 External Dimensions for Full Headform Size F2220-J**

NOTE 1—Angles in degrees with a tolerance of  $\pm 0.5^\circ$ . Radii in millimetres, with a tolerance of  $\pm 1.0\%$ . Datum levels with a tolerance of  $\pm 0.5$  mm.

NOTE 2—The full size headform shall have a jaw line which resembles the human jaw. This jaw line should be radiused along its length to eliminate any sharp edges. The base of the neck shall be squared off perpendicular to the central vertical axis.

NOTE 3—Those data points which form the chin of the headform are permitted to exceed the published tolerance once a radius has been applied.

F2220 - J	Angle													
	0° Front	15°	30°	45°	60°	75°	90°	105°	120°	135°	150°	165°	180° Rear	
Height Above Reference Plane (mm)	102.5	102.5	102.5	102.5	102.5	102.5	102.5	102.5	102.5	102.5	102.5	102.5	102.5	102.5
	100	102.0	101.9	101.8	101.7	101.6	101.7	101.9	102.2	102.8	103.6	104.4	104.8	104.7
	95	102.0	101.8	101.4	101.0	100.7	100.6	100.9	101.7	102.9	104.5	105.9	106.4	106.3
	90	102.3	102.2	101.7	100.9	100.1	99.8	100.1	101.0	102.6	104.7	106.4	107.0	106.9
	85	102.8	102.6	102.1	100.9	99.5	98.9	99.15	100.3	102.1	104.5	106.5	107.1	107.1
	80	103.2	103.0	102.3	100.7	98.8	97.8	98.1	99.4	101.5	104.0	106.3	107.1	107.0
	70	103.5	103.1	102.1	99.8	96.9	95.4	95.6	97.2	99.7	102.8	105.5	106.5	106.4
60	103.1	102.6	101.3	97.9	94.6	92.6	92.9	94.7	97.6	101.1	104.3	105.5	105.5	
50	102.6	101.7	100.0	96.5	92.0	89.7	90.1	92.1	95.2	99.3	102.9	104.4	104.5	
40	101.5	100.7	98.5	94.3	89.2	86.9	87.3	89.5	92.9	97.4	101.3	103.3	103.4	
20	100.6	99.2	95.8	90.1	84.6	81.9	82.0	84.5	88.5	94.0	98.5	101.3	101.6	
Reference Plane	0	101.0	99.5	95.5	88.5	82.5	79.5	79.5	82.0	86.0	92.0	97.0	100.5	101.0
Depth Below Reference Plane (mm)	-12.7	101.8	100.3	95.4	85.9	79.0	76.6	76.6	79.0	83.0	88.9	93.9	97.3	97.8
	-22.7	103.5	103.0	97.2	87.5	79.3	75.5	74.1	76.9	80.3	86.1	90.9	94.3	94.8
	-35	106.9	107.8	98.9	88.7	81.9	79.2	73.0	75.2	78.7	83.7	88.2	91.0	91.5
	-45	110.6	111.5	100.6	90.9	84.9	82.0	76.2	77.4	79.9	83.6	87.0	89.2	88.8
	-60	117.5	118.3	106.5	97.2	91.4	85.9	84.2	84.5	85.6	88.1	90.3	91.1	89.9
	-75	125.8	126.6	114.1	105.4	100.6	96.1	94.5	95.1	95.4	96.1	96.4	97.0	97.3
	-85	132.0	132.8	119.5	111.1	107.6	102.9	102.6	103.2	103.5	104.0	104.3	104.9	105.2
	-90	135.3	136.0	121.4	113.4	106.3	106.5	106.8	107.3	107.6	108.2	108.4	109.0	109.3
	-96.5	139.7	140.4	125.0	110.8	111.8	112.1	112.3	112.9	113.1	113.6	113.9	114.4	114.7
	-106	146.4	147.1	119.0	119.2	120.1	120.4	120.6	121.1	121.3	121.8	122.1	122.6	122.8
-136	146.1	146.1	146.3	146.5	147.3	147.5	147.7	148.1	148.3	148.7	148.9	149.3	149.5	

Distance from reference plane to top of headform: 102.5 mm

Depth to basic plane: -27.5 mm

**TABLE A1.5 External Dimensions for Full Headform Size F2220-M**

NOTE 1—Angles in degrees with a tolerance of  $\pm 0.5^\circ$ . Radii in millimetres, with a tolerance of  $\pm 1.0\%$ . Datum levels with a tolerance of  $\pm 0.5$  mm.

NOTE 2—The full size headform shall have a jaw line which resembles the human jaw. This jaw line should be radiused along its length to eliminate any sharp edges. The base of the neck shall be squared off perpendicular to the central vertical axis.

NOTE 3—Those data points which form the chin of the headform are permitted to exceed the published tolerance once a radius has been applied.

F2220 - M	Angle													
	0° Front	15°	30°	45°	60°	75°	90°	105°	120°	135°	150°	165°	180° Rear	
Height Above Reference Plane (mm)	105	105.7	105.7	105.8	105.9	106.0	106.2	106.5	106.8	107.3	108.0	108.9	109.4	109.4
	100	105.0	105.1	105.2	105.5	105.6	105.6	105.7	106.1	107.0	108.7	110.5	111.1	111.0
	95	105.5	105.5	105.7	105.7	105.0	104.7	104.8	105.3	106.5	108.7	110.9	111.6	111.5
	90	106.3	106.2	106.3	105.6	104.3	103.7	103.7	104.4	106.0	108.6	110.9	111.7	111.6
	85	107.0	107.0	106.7	105.3	103.5	102.5	102.5	103.4	105.4	108.3	110.6	111.6	111.4
	80	107.6	107.5	107.0	105.0	102.6	101.2	101.2	102.2	104.8	107.9	110.3	111.4	111.1
	70	107.9	108.0	107.0	103.9	100.6	98.6	98.5	99.9	103.1	106.6	109.2	110.6	110.5
	60	107.7	107.6	106.5	102.4	98.3	96.0	95.9	97.5	101.1	104.9	108.2	109.8	109.8
	50	107.3	106.8	105.5	100.6	95.9	93.5	93.4	95.2	98.9	103.0	106.4	108.6	109.0
	40	106.7	105.9	104.2	98.8	93.5	91.3	91.0	93.0	96.8	101.3	104.8	107.7	108.3
20	105.9	104.4	101.8	95.3	89.4	87.1	86.7	89.0	93.2	98.0	103.0	106.9	106.9	
Reference Plane	0	106.0	104.0	101.0	93.5	87.0	84.5	84.0	86.5	91.0	96.0	102.0	106.0	106.0
Depth Below Reference Plane (mm)	-13.3	106.8	104.8	99.4	89.5	82.6	80.1	80.1	82.6	86.5	93.0	97.9	101.4	102.4
	-23.7	108.6	107.6	101.3	91.1	83.0	78.7	77.2	80.1	83.9	89.7	95.0	98.4	98.9
	-36.5	112.1	112.6	103.2	92.5	85.7	82.5	76.3	78.5	82.1	87.5	92.0	94.8	95.3
	-47	116.0	116.4	105.1	94.9	88.5	85.6	79.4	81.0	83.5	87.2	91.1	93.6	92.8
	-62.6	123.1	123.5	111.3	101.6	95.4	89.5	87.8	88.1	89.2	92.1	94.3	95.0	93.9
	-78.3	131.8	132.2	119.3	109.8	105.0	100.2	98.6	99.3	99.6	100.2	100.5	101.1	101.4
	-88.7	138.2	138.6	124.6	115.8	112.4	107.4	107.1	107.7	107.9	108.5	108.8	109.4	109.7
	-94	141.7	142.1	126.7	118.4	111.0	111.2	111.5	112.1	112.3	112.9	113.2	113.7	114.0
	-100.7	146.2	146.6	137.1	115.7	116.7	117.0	117.2	117.7	118.0	118.5	118.8	119.3	119.6
	-110.7	153.3	153.6	124.3	124.5	125.4	125.7	125.9	126.4	126.6	127.1	127.4	127.9	128.1
-142	152.6	152.6	152.8	153.0	153.8	154.0	154.2	154.5	154.7	155.1	155.3	155.8	156.0	

Distance from reference plane to top of headform: 107.0 mm

Depth to basic plane: -29.0 mm

**TABLE A1.6 External Dimensions for Full Headform Size F2220-O**

NOTE 1—Angles in degrees with a tolerance of  $\pm 0.5^\circ$ . Radii in millimetres, with a tolerance of  $\pm 1.0\%$ . Datum levels with a tolerance of  $\pm 0.5$  mm.

NOTE 2—The full size headform shall have a jaw line which resembles the human jaw. This jaw line should be radiused along its length to eliminate any sharp edges. The base of the neck shall be squared off perpendicular to the central vertical axis.

NOTE 3—Those data points which form the chin of the headform are permitted to exceed the published tolerance once a radius has been applied.

F2220 - O	Angle													
	0° Front	15°	30°	45°	60°	75°	90°	105°	120°	135°	150°	165°	180° Rear	
Height Above Reference Plane (mm)	105	108.5	108.4	108.3	108.3	108.4	108.5	108.8	109.1	109.8	110.7	111.9	112.2	112.3
	100	108.6	108.5	108.4	108.2	107.9	107.8	108.1	108.8	110.2	112.4	113.9	113.9	113.8
	95	108.9	109.0	109.1	108.4	107.3	107.0	107.4	108.3	110.0	112.4	114.2	114.3	114.1
	90	109.5	109.6	109.8	108.4	106.6	106.0	106.4	107.5	109.5	112.2	114.4	114.4	114.3
	85	110.2	110.2	110.3	108.3	105.9	105.0	105.3	106.6	108.9	111.9	114.3	114.3	114.2
	80	110.7	110.7	110.6	108.1	105.1	103.8	104.1	105.6	108.2	111.4	114.1	114.0	114.0
	70	111.0	111.1	110.7	107.0	103.1	101.4	101.5	103.4	106.5	110.1	113.5	113.2	113.2
	60	110.6	110.6	110.0	106.0	101.0	98.8	98.9	101.1	104.5	108.7	112.4	112.3	112.4
	50	109.8	109.8	108.7	103.9	99.0	96.3	96.5	98.7	102.5	107.0	111.3	111.4	111.7
	40	109.0	108.8	107.7	101.7	96.7	94.0	94.0	96.7	100.5	105.4	110.0	110.5	110.8
20	108.1	107.4	104.9	98.1	92.7	89.9	89.6	92.6	96.7	102.1	106.9	109.3	109.2	
Reference Plane	0	108.5	107.5	103.5	96.0	90.5	87.5	87.0	90.0	94.5	100.0	105.0	108.0	108.5
Depth Below Reference Plane (mm)	-13.7	109.4	108.4	102.4	92.5	85.1	82.2	82.2	85.1	89.1	95.5	100.9	104.3	105.4
	-24.4	111.2	110.7	104.4	94.2	85.1	81.3	79.8	82.7	86.5	92.3	97.6	101.5	102.0
	-37.6	114.8	115.8	106.4	95.2	87.9	85.2	78.6	80.8	84.8	89.8	94.8	98.0	98.5
	-48.4	118.8	119.7	108.4	97.8	91.4	88.0	81.8	83.1	85.9	90.1	93.5	96.5	95.2
	-64.5	126.2	127.1	114.4	104.3	98.2	92.3	90.5	90.9	91.9	94.8	97.0	97.8	96.7
	-80.6	135.2	136.0	122.7	113.2	108.1	103.2	101.7	102.3	102.6	103.2	103.5	104.2	104.5
	-91.4	141.9	142.6	128.6	119.5	115.7	110.4	110.4	111.0	111.3	111.9	112.2	112.7	113.0
	-96.8	145.4	146.2	130.5	121.8	114.2	114.4	115.0	115.5	115.8	116.3	116.6	117.2	117.4
	-103.9	150.2	150.9	134.6	119.2	120.2	120.5	121.0	121.5	121.8	122.3	122.6	123.1	123.4
	-114	157.4	158.0	127.9	128.1	129.1	129.3	129.8	130.2	130.5	131.0	131.2	131.7	132.0
-146.2	157.1	157.1	157.3	157.5	158.2	158.4	158.8	159.2	159.4	159.8	160.0	160.4	160.6	

Distance from reference plane to top of headform: 110.0 mm  
 Depth to basic plane: -30.0 mm

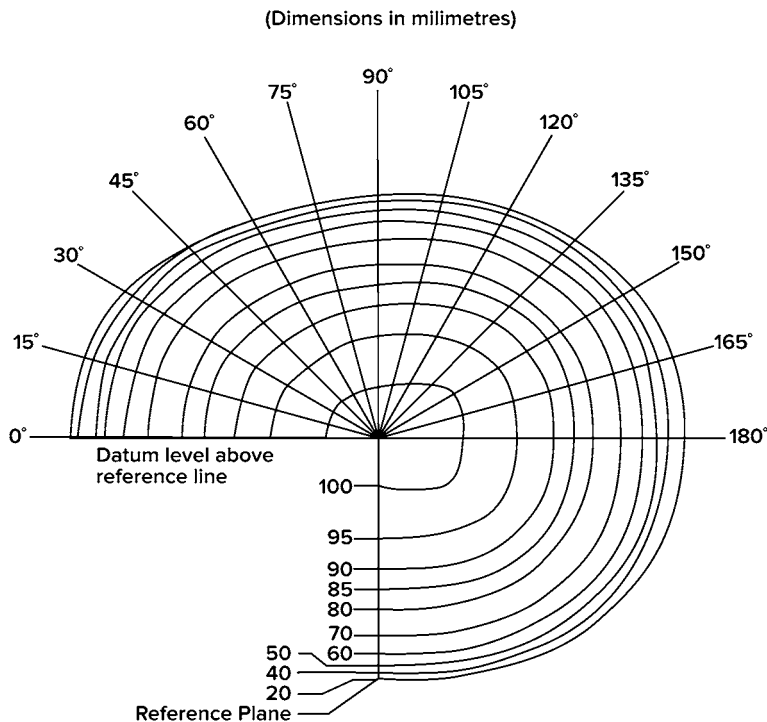

**FIG. A1.2 Horizontal Half-Sections at Datum Levels**

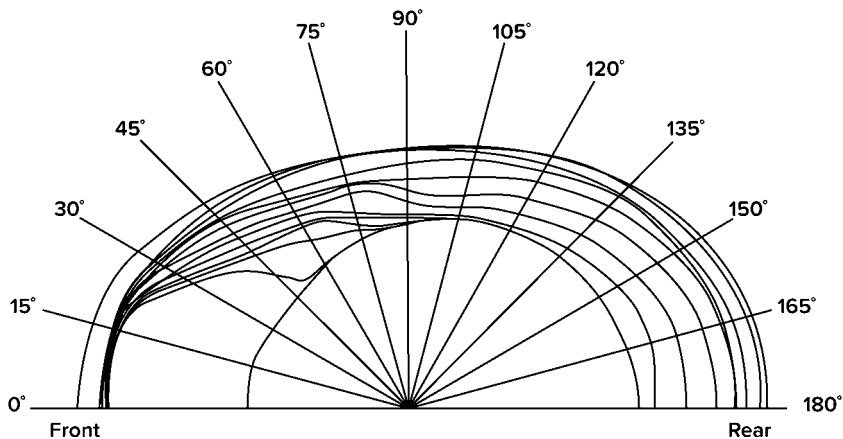

FIG. A1.3 Horizontal Half-Sections at Datum Levels

ASTM International takes no position respecting the validity of any patent rights asserted in connection with any item mentioned in this standard. Users of this standard are expressly advised that determination of the validity of any such patent rights, and the risk of infringement of such rights, are entirely their own responsibility.

This standard is subject to revision at any time by the responsible technical committee and must be reviewed every five years and if not revised, either reapproved or withdrawn. Your comments are invited either for revision of this standard or for additional standards and should be addressed to ASTM International Headquarters. Your comments will receive careful consideration at a meeting of the responsible technical committee, which you may attend. If you feel that your comments have not received a fair hearing you should make your views known to the ASTM Committee on Standards, at the address shown below.

This standard is copyrighted by ASTM International, 100 Barr Harbor Drive, PO Box C700, West Conshohocken, PA 19428-2959, United States. Individual reprints (single or multiple copies) of this standard may be obtained by contacting ASTM at the above address or at 610-832-9585 (phone), 610-832-9555 (fax), or [service@astm.org](mailto:service@astm.org) (e-mail); or through the ASTM website ([www.astm.org](http://www.astm.org)). Permission rights to photocopy the standard may also be secured from the Copyright Clearance Center, 222 Rosewood Drive, Danvers, MA 01923, Tel: (978) 646-2600; <http://www.copyright.com/>