



# Standard Specification for Selectorized Strength Equipment<sup>1</sup>

This standard is issued under the fixed designation F2216; the number immediately following the designation indicates the year of original adoption or, in the case of revision, the year of last revision. A number in parentheses indicates the year of last reapproval. A superscript epsilon ( $\epsilon$ ) indicates an editorial change since the last revision or reapproval.

## INTRODUCTION

The goal of this specification is to promote proper design and manufacturing practices for selectorized strength training equipment. Through these specifications, this specification aims to assist designers and manufacturers in reducing the possibility of injury when these products are used in accordance with the operational instructions.

The equipment user must recognize, however, that a standard alone will not necessarily prevent injuries. Like other physical activities, exercise involving selectorized strength training equipment involves the risk of injury, particularly if the equipment is used improperly or not properly maintained. In addition, users with physical limitations should seek medical advice and instruction from the fitness facility prior to using this equipment. Certain physical conditions or limitations may preclude some persons from using this equipment properly and without increasing the risk of serious injury.

## 1. Scope

1.1 This specification establishes parameters for the design and manufacture of selectorized strength training equipment as defined in 3.1.

1.2 It is intended that these fitness products be used in an indoor setting or environment.

1.3 It is the intent of this standard to specify fitness products for use only by individuals age 13 and older.

1.4 This standard is to be used in conjunction with Specification F2276, Test Methods F2571, and Test Method F2277.

1.5 This standard takes precedence over Specification F2276 and Test Methods F2571 in areas that are specific or unique to selectorized strength training equipment.

1.6 The values stated in SI units are to be regarded as the standard. The values in parentheses are for information only.

1.7 *This standard does not purport to address all of the safety concerns, if any, associated with its use. It is the responsibility of the user of this standard to establish appropriate safety and health practices and determine the applicability of regulatory limitations prior to use.*

## 2. Referenced Documents

2.1 *ASTM Standards:*<sup>2</sup>

F1749 Specification for Fitness Equipment and Fitness Facility Safety Signage and Labels

F2276 Specification for Fitness Equipment

F2277 Test Methods for Evaluating Design and Performance Characteristics of Selectorized Strength Equipment

F2571 Test Methods for Evaluating Design and Performance Characteristics of Fitness Equipment

## 3. Terminology

3.1 *Definitions:*

3.1.1 *assist means, n*—mechanism that the user engages on the machine to assist them in getting into and out of the loaded starting position.

3.1.2 *cam, n*—rotational component controlling the resistance to the user.

3.1.3 *catch point, n*—location at which edges, protrusions, or surfaces allow a body part to become injured.

3.1.4 *consumer selectorized strength equipment, n*—selectorized strength equipment intended for home use or for use in a home environment.

3.1.4.1 *Discussion*—Since significant differences can arise between consumer and institutional selectorized strength equipment, the products must be clearly identified as not for commercial use.

<sup>1</sup> This specification is under the jurisdiction of ASTM Committee F08 on Sports Equipment, Playing Surfaces, and Facilities and is the direct responsibility of Subcommittee F08.30 on Fitness Products.

Current edition approved March 1, 2012. Published March 2012. Originally approved in 2003. Last previous edition approved in 2005 as F2216–05. DOI: 10.1520/F2216-12.

<sup>2</sup> For referenced ASTM standards, visit the ASTM website, [www.astm.org](http://www.astm.org), or contact ASTM Customer Service at [service@astm.org](mailto:service@astm.org). For *Annual Book of ASTM Standards* volume information, refer to the standard's Document Summary page on the ASTM website.

3.1.5 *field of view, n*—field of view of the user defined by an arc of 150°. Seventy-five degrees on each side of the median plane.

3.1.6 *foot support, n*—machine component(s) contacting the user’s feet during operation, entry, and exit from the machine.

3.1.7 *institutional strength equipment, n*—strength equipment intended for use by numerous persons in a commercial or institutional facility, as opposed to home environment.

3.1.8 *median plane, n*—plane of reference that divides the midline of the body of the user into equal right and left halves.

3.1.9 *rope, n*—for the purpose of this specification, a cord comprised of intertwisted synthetic or natural fibers or steel wires used for the transmittal of load from the resistance means to the user means.

3.1.10 *selector pin, n*—the component used to select resistance on weight based selectorized strength equipment.

3.1.11 *selectorized strength equipment, n*—strength equipment where the resistance means is an integral part of the machine and may be varied easily by the user.

3.1.12 *strength equipment, n*—fitness equipment designed to strengthen one or more groups of muscles anaerobically.

3.1.13 *user means, n*—movable component or assembly that the user contacts to perform the exercise.

3.1.14 *user support means, n*—portion of the machine (seat, platform, etc.) that supports the user while the user is performing the exercise.

**4. General Requirements**

**4.1 Construction:**

4.1.1 *Weights*—Weights shall move only when displaced intentionally. Weights shall move freely along their guide means and return to the resting point. The travel of the weights shall be controlled by the user such that no uncontrolled pendulum swing shall occur.

4.1.2 *Weight Selection Pin*—Weight selection pins shall be fitted with a positive retention means.

4.1.3 *Machine Ingress and Egress*—If the user cannot (after adjusting the machine according to the manufacturer’s instructions) attain the loaded starting position for the machine, then the machine shall be provided with an assist means.

4.1.4 *Ropes, Belts, Chains, or Other Means*—Ropes, belts, chains, and other means, including all attachment devices (links, shackles, end fittings, and termination means) shall not fail with a load equal to six times the maximum static tension developed by the machine during operation and shall pass the endurance guidelines set forth in 4.4.1. All end terminations shall not be subjected to cyclic bending under normal machine operation as defined by the manufacturer.

4.1.5 *Pulleys*—Pulleys for rope/belt drive machines shall rotate freely under all extrinsic loads.

4.1.5.1 *Wire Rope Pulleys*—The groove radius, *r*, of the pulley for wire rope driven machines shall meet the wire rope manufacturer’s guidelines, allow for passing of the endurance guidelines set forth in 4.5.3 or lie within the range given by the following equation, or both:

$$\frac{C_d}{2} + 5\% \text{ to } \frac{C_d}{2} + 15\% \tag{1}$$

with  $C_d / 2 + 10\%$  being the optimum.  $C_d$  is defined as the nominal wire rope diameter including coating. The tread diameter, *d*, of the pulley shall be a minimum of 18 times greater than the bare wire rope diameter (without coating). See Fig. 1.

4.1.5.2 *Belt Pulleys*—The diameter of the pulley shall be of sufficient size to yield a belt life meeting the parameters specified in 4.4.1. Belt pulleys shall be designed to prevent disengagement.

4.1.6 *Rope/Belt Guards*—Disengagement of ropes/belts shall be prevented by the provision of adequate retention guards or enclosures.

**4.2 Entrapment Points:**

4.2.1 *General Comments*—Unlike other machinery, selectorized strength equipment is fully controlled by the user of the equipment. It is therefore assumed that the user shall take responsibility for his/her actions while using the machine and can prevent the inadvertent contact with machine components within the user’s field of view by the user or a third party by stopping the exercise or movement of the machine. For this reason, the discussion of entrapment points is broken down into “within” and “outside” the field of view of the user. Wherever possible, the design of movable components shall avoid catch, shear, or pull-in points.

4.2.1.1 In general, the fingers are the body components most likely to be injured. The primary exception to this is weight stacks where feet or hands, or both, could also be injured. Weight stacks shall be spaced less than 9.5 mm (0.375 in.) or greater than 25 mm (0.98 in.) from any fixed frame member. This spacing shall remain constant through the travel range of

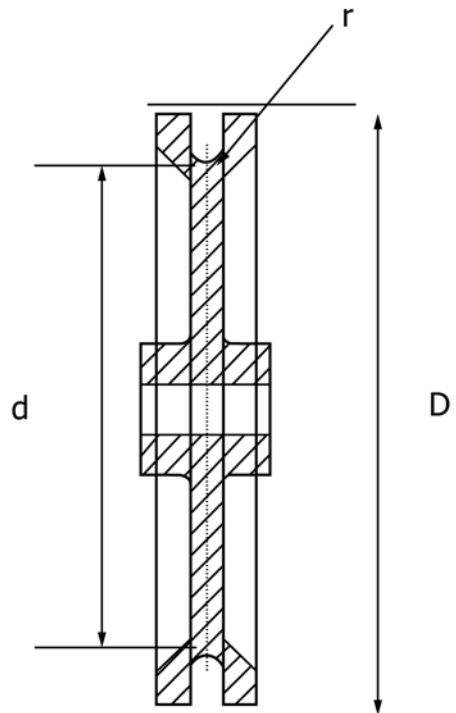

FIG. 1 Wire Rope Pulley Profile

the weight stack. Weight stacks shall be spaced at least 25 mm (0.98 in.) from the base frame of the machine. Strength equipment that includes weight stack enclosures designed in accordance with 4.3 as a permanent feature of the machine are exempt from this requirement, provided that the enclosure extends past the rest position of the bottom weight plate.

4.2.1.2 The user means or other moving components, or both, shall not pass within 60 mm (2.36 in.) of the moving weight stack during the normal operation of the machine, as defined in the instructions provided by the manufacturer. Mechanical stops are generally provided at one or both extremes of the user means range of travel. Since the user means will contact the stops at these locations, they are excluded from the clearance requirements. However, if the stop is physically part of the moving user means, then it shall pass no closer than 25 mm (0.98 in.) to any fixed frame members throughout its range of travel.

4.2.1.3 If the machine framework or the user’s body placement, while using the machine in accordance with the manufacturer’s instructions, prevents the uncontrolled access of a third party into the area of concern, then guarding is not required. The user’s body shall prevent access throughout the entire exercise range of motion.

4.2.2 *Outside the Field of View*—To a height of 1800 mm (70.8 in.), the distance between movable components or between a movable and fixed component shall be at least 60 mm (2.36 in.) when body parts other than the fingers are at risk. This dimension may be reduced to no less than 25 mm (0.98 in.) when only the fingers are at risk. If the spacing between moving components or between fixed and moving components remains constant throughout the range of motion of the machine, then the spacing shall be greater than 25 mm (0.98 in.) or less than 9.5 mm (0.375 in.). Guarding shall be provided if the design does not allow the above dimensions to be met.

4.2.3 *Within the Field of View and Within Reach of the User*—If distances do not conform to those specified in 4.2.2, the components shall be guarded or enclosed.

4.2.4 *Within the Field of View and Outside the Reach of the User*—Pinch and shear points within the user’s field of view but accessible only to a third party shall not be located within 25 mm (0.98 in.) of a stationary component. Alternatively, such points can be less than 9.5 mm (0.375 in.) from a stationary component if the spacing between the components remains constant throughout the range of movement of the machine.

4.2.5 *Pull-In Points*—Finger pull-in occurs when the spacing between the fixed and rotating component is less than 25 mm (0.98 in.) or when the angle between the fixed guard and the belt or rope is less than 50°, or both (see Fig. 2). For ropes and pulleys or ropes and cams, pull-in will occur during the portion of the exercise stroke that the rope wraps onto the rotating element or passes into the guard. This can occur on both sides of a pulley or guard as shown in Fig. 2 and Fig. 3. Fig. 4 illustrates a circular pulley or cam guard. To achieve a pull-in angle greater than 50°, the guard radius  $G_r$  shall be calculated using the following equation:

$$G_r > \left[ \frac{d}{2} + \frac{C_d}{2} \right] / \cos 50^\circ \quad (2)$$

where  $d$  and  $C_d$  have been defined in 4.1.5.1 and 4.1.5.2.

4.2.5.1 *Outside the Field of View*—Pull-in points up to a height of 1800 mm (70.8 in.) shall be guarded or spaced greater than 25 mm (0.98 in.) apart so that the user’s or third party’s fingers, when extended, cannot be caught between the components (see Fig. 2). Rope, belt, or rope driven machines where the pressure between the rope/belt and the cam or pulley is less than 90 N/cm<sup>2</sup> (131 psi) are excluded from this requirement.

4.2.5.2 *Within the Field of View*—Pull-in points shall be guarded so that the user’s fingers, when extended from the

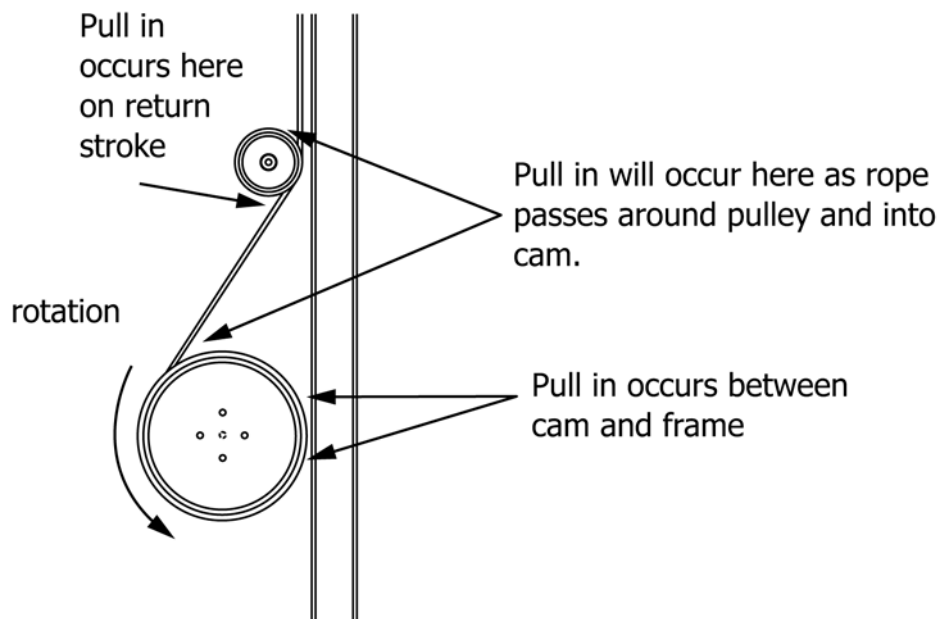

FIG. 2 Guarding of Pull-In Points—Unguarded

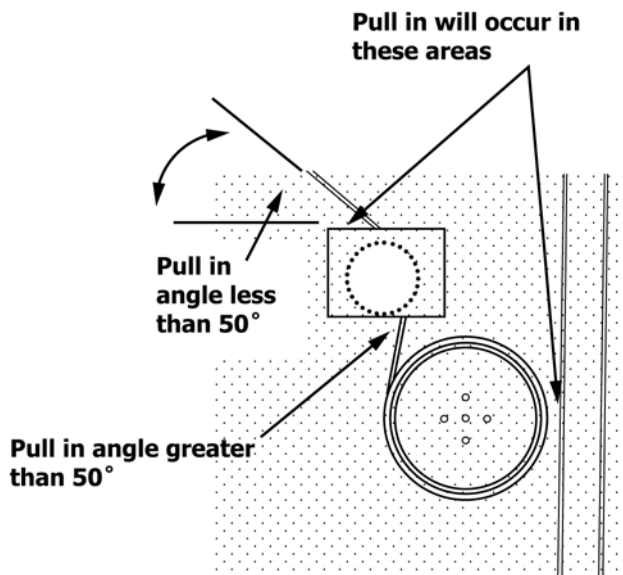

FIG. 3 Guarding of Pull-In Points—Pulley Guarding

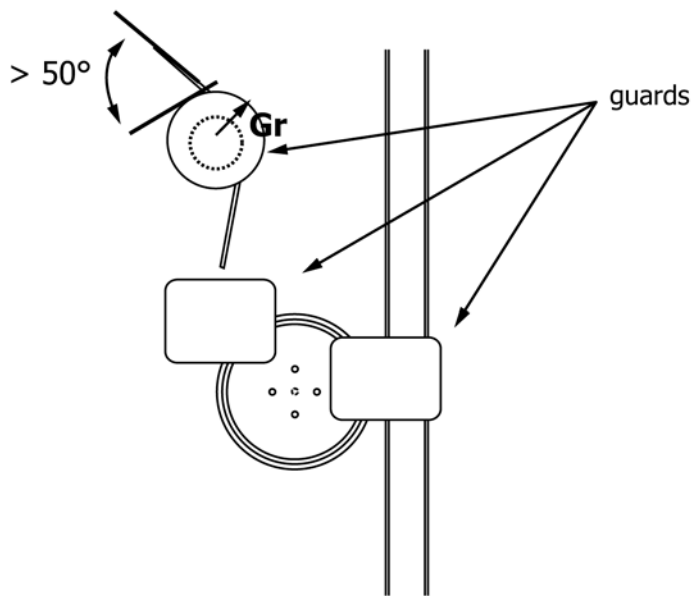

FIG. 4 Guarding of Pull-In Points—Guarded

exercise position, cannot be caught between the components. Pull-in points within the field of view of the user, during the entire range of motion of the exercise being performed, but accessible only to a third party, need not be guarded because the user can control the motion of the machine and thus prevent any inadvertent contact with a third party. A site specific label shall be present in the immediate location of the pull-in point, alerting the user or a third party to the potential for injury and to stay clear of the area. Rope or belt driven machines where the pressure between the rope/belt and the cam or pulley is less than 90 N/cm<sup>2</sup> (131 psi) are excluded from the requirements of 4.2.5.1 and 4.2.5.2.

#### 4.3 Weight Stack Enclosures:

4.3.1 *General*—Unlike other fitness equipment, selectorized strength equipment is fully controlled by the user. Stopping the

exercise or the machine’s movement permits the user to prevent inadvertent contact with weight stacks within the field of view of the user. Weight stack enclosures may assist in preventing uncontrolled access by third parties outside this field of view. Weight stack enclosures shall be made available as an additional option by the manufacturer to the purchaser of institutional selectorized strength equipment. Weight stack enclosures shall be designed in accordance with the parameters outlined in 4.3.2 – 4.3.4. For consumer selectorized strength equipment, the manufacturer shall provide either weight stack enclosures designed to the parameters detailed in 4.3.2 – 4.3.4 or provide a lock out mechanism to secure the weight stack and prevent inadvertent use by children. Instructions and warnings shall state that this mechanism must be secured after use of the machine.

4.3.1.1 *Discussion*—The dimensions specified in 4.3.2 – 4.3.4 shall allow for free travel of the weights and insertion of the selector pin. Compliance with these specifications, however, may not necessarily prevent children from being injured by moving weights. In addition, an enclosure may block the user’s field of view of third parties including children. As specified in 4.6.1, manufacturers shall affix warnings to the machine alerting to keep children away. Multiple weight stack machines do not require guarding on the three sides furthest from the user, provided that there is sufficient framework on these sides to prevent the inadvertent access by third parties. On the side adjacent to the user enclosures shall be designed in accordance with 4.3.2 – 4.3.4. Fig. 5 depicts the placement possibilities of the weight stacks on selectorized strength equipment with respect to the user and a plane of reference through the top surface of the seat back pad.

4.3.2 *Weight Stack in Front of User*—When the weight stack is in front of the user (see Fig. 6), and it is always within the user’s field of view throughout the entire exercise movement, the weights need not be enclosed. The user shall face the weights at all times during the exercise and this shall be specified in the instructions supplied by the manufacturer.

4.3.3 *Weight Stack Behind the User*—When the weight stack is positioned behind the user (see Fig. 7) the weights shall be completely enclosed up to a height of 60 mm (2.36 in.) beyond the furthest possible travel of the weight stack as determined by use of the machine in accordance with instructions supplied by the manufacturer. The enclosure shall extend past the rest position of the bottom weight plate. The only opening shall be a slot no greater than 75 mm (2.95 in.) wide for the insertion and operation of the weight selector pin. The horizontal spacing between the open edges of the enclosure and the weights shall be less than 9.5 mm (0.375 in.) or greater than 25 mm (0.98 in.).

4.3.4 *Weight Stack to the Side of the User*—When the weight stack is positioned to the side of the user (see Fig. 8), the amount of enclosure shall be dependent on the placement of the weight stack relative to the user’s field of view and the pad reference plane. Weight stacks that are located to the side of the user and extend beyond any portion of the pad reference plane either at rest, or during the execution of the exercise (see Fig. 8-Part A), shall be enclosed in accordance with 4.3.3. When encased only on three sides (Fig. 8-Part B), the enclosure shall meet the height guidelines of 4.3.3, and at a minimum, be flush with the front of the weights with the spacing being less than 9.5 mm (0.375 in.) or greater than 25 mm (0.98 in.) as shown in Fig. 9. Encasement of the weights is not required when the weight stack is within the field of view of the user (Fig. 8-Part C) and it does not become obscured by the user or the machine during the performance of the exercise.

4.4 *Loading:*

4.4.1 *Endurance Loading:*

4.4.1.1 Institutional selectorized strength training equipment shall withstand 250 000 cycles at the maximum specified load over 80 % of the possible range of movement (this includes all belts or ropes and mechanical components). Mechanical components of consumer selectorized strength equipment shall withstand 14 000 cycles at the maximum specified load over 80 % of the possible range of movement. Ropes on consumer selectorized equipment shall withstand 14 000 cycles at the maximum specified load over 80 % of the possible range of movement.

4.4.1.2 When the equipment consists of two or more separate functional units, each shall withstand the endurance load test. When more than one function is to be tested, any common components (ropes, selector pins, pulleys, and so forth) may be replaced prior to commencing the next test. Multistation

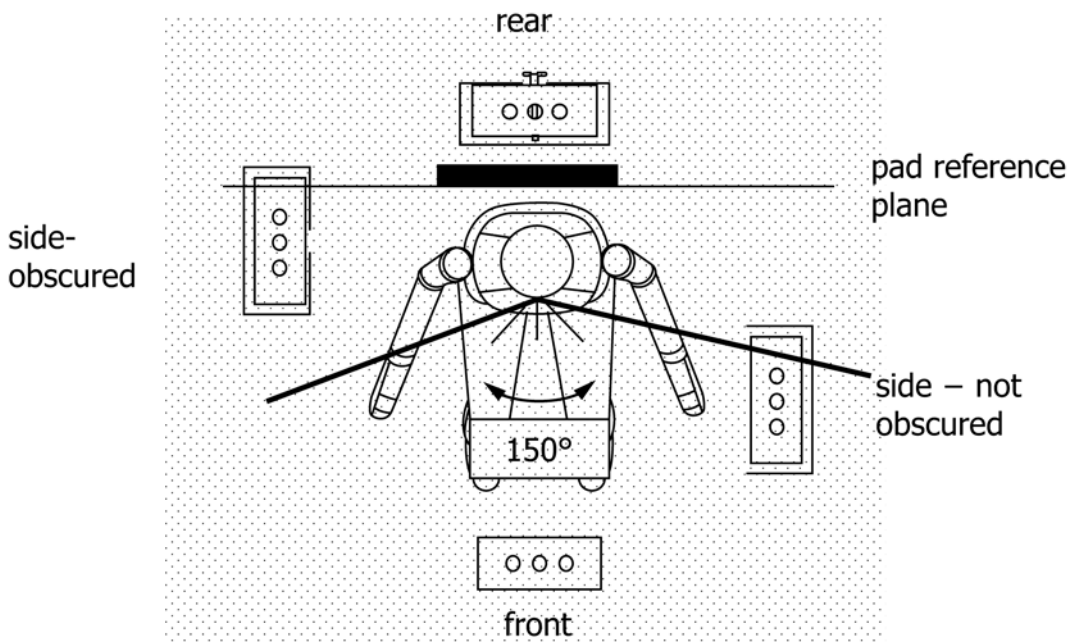

FIG. 5 Possible Weight Stack Placement

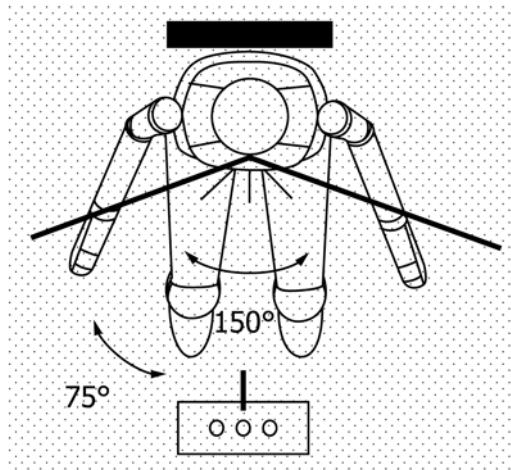

FIG. 6 Weights to Front of User

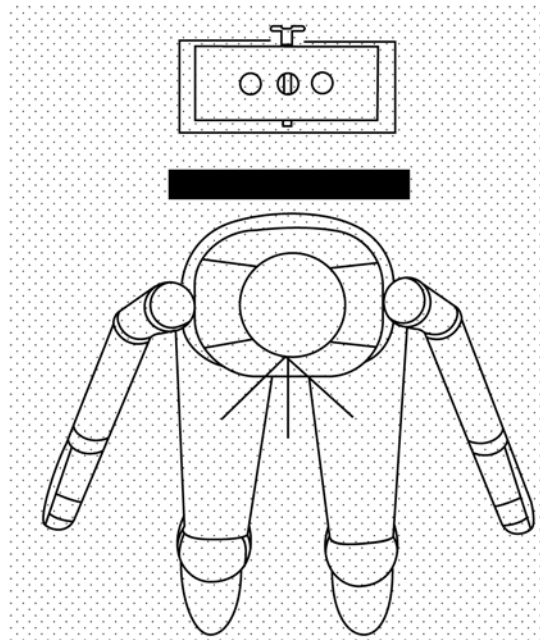

FIG. 7 Weight to Rear of User

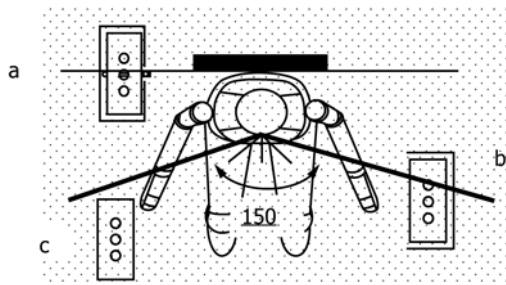

FIG. 8 Weight to Side of User

period if the number of stations to be tested causes the frame to experience cycles in excess of the numbers stated above. Tests for endurance shall apply loads to the machine in the same manner that the machine receives loading when it is operated in accordance with the manufacturer's operation instructions. After the test, the equipment shall be capable of normal function.

4.5 Documentation:

4.5.1 *Owner's/User's Manual*—An owner's/user's manual shall be provided with selectorized strength equipment. A single manual may be used by manufacturers to address commonalities of specific product lines offered by the manufacturer. If individual machines in the product line have unique usage or safety concerns then they shall be addressed in separate sections within the manual or by a manual devoted specifically to the machine. Sections 4.5.2 – 4.5.6 describe the

strength equipment may have several exercise stations sharing a common frame. In this case then the frame shall withstand 500 000 cycles for institutional machines and 28 000 cycles for consumer products. The frame may be replaced during the test

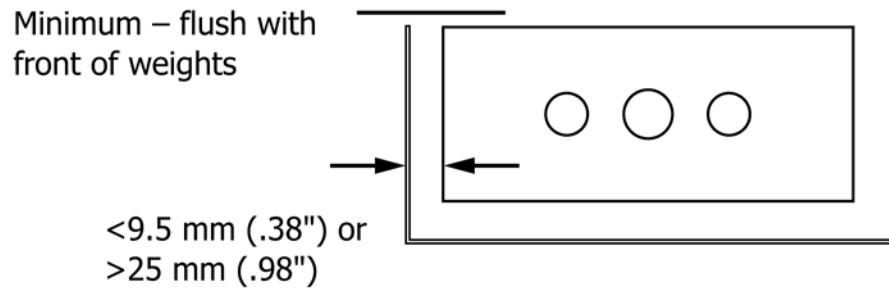

FIG. 9 Weight Enclosure Spacing

sections to be covered in this manual. The first topic of the manual shall be a comprehensive listing of the safety precautions applicable to the machine. This listing shall alert the reader to the following:

4.5.1.1 Read all warnings posted on the machine.

4.5.1.2 Read the owner's/user's manual and follow it carefully before using the machine. In an institutional environment, it is the facility owner's responsibility to properly instruct users on the proper operation of the equipment and to warn them of the potential hazards. The manual shall alert the reader to this fact.

4.5.1.3 Keep children away from selectorized strength equipment. Parents or others supervising children must provide close supervision of children if the equipment is used in the presence of children. The manual shall alert the reader of this fact.

4.5.1.4 The weight stack or top plate should never be pinned in an elevated position. The machine must not be used if found in this condition (for selectorized strength equipment that employ weight stacks).

4.5.1.5 Be certain that the weight pin is completely inserted (for selectorized strength equipment that employ weight stacks).

4.5.1.6 Inspect the machine for worn or loose components prior to use. Tighten/replace any loose or worn components prior to using. Pay close attention to ropes, belts, or chains and their connections.

4.5.1.7 Never use dumbbells or other means to incrementally increase the weight resistance. Use only those means provided by the manufacturer.

4.5.1.8 Set up and operate selectorized strength equipment on a solid level surface.

4.5.1.9 Do not wear loose or dangling clothing or jewelry while using selectorized strength equipment. Stay clear of all moving components.

4.5.1.10 Consult a physician prior to commencing an exercise program. If at any time during exercise you feel faint, dizzy, or experience pain, stop and consult your physician.

4.5.1.11 If the selectorized strength equipment is intended for consumer use only, then the reader shall be alerted to that fact.

4.5.1.12 Do not exceed the maximum specified user weight. Manufacturer to state the maximum user weight in this warning.

4.5.1.13 Notice to the reader or user of the product, or both, that the machine meets industry standards for stability when used for its intended purpose in accordance with the instruc-

tions provided by the manufacturer. Warnings shall be included instructing that using the machine for support during stretching or allowing resistance straps, ropes, or other means to be attached to it may result in serious injury.

4.5.2 *Assembly Instructions*—If the equipment requires assembly, a manual shall be supplied giving clear, detailed assembly instructions for the equipment. Equipment requiring assembly shall include a listing of the tools required for assembly, even if the tools are supplied by the manufacturer. Equipment requiring assembly shall include a comprehensive parts listing, including part or reference numbers of those components to be assembled. Equipment that requires attachment to the floor shall include instructions on how to secure the equipment to the floor. The recommended minimum area for access and operation of the machine shall be defined in these instructions. Functional and visual inspection of the equipment shall be made after assembly is complete. Review of all warnings affixed to the machine shall be provided in these assembly instructions.

4.5.3 *Maintenance Instructions*—Care and necessary maintenance advice shall be provided. This shall include a review of all applicable warning notices. Special attention shall be drawn to ropes, belts, or chains, and their terminations or connection points.

4.5.3.1 The safety and integrity designed into a machine can only be maintained when the equipment is regularly examined for damage and repair. It is the sole responsibility of the user/owner or facility operator to ensure that regular maintenance is performed. Worn or damaged components shall be replaced immediately or the equipment removed from service until the repair is made. Only manufacturer supplied components shall be used to maintain/repair the equipment. The maintenance instructions shall call the reader's attention to these facts.

4.5.4 *Operational Instructions*—Each function of the machine shall be explained in the operation instructions. The first category of the operational instructions shall call the user's attention to read and understand the other warnings affixed to the machine. In the case of single function institutional selectorized strength machines, these instructions shall be affixed directly to the machine. Where possible, the use of graphics shall be provided to assist in proper depiction of the use of the equipment. For multistation or multifunction institutional selectorized strength equipment, the instructions shall be provided on individual placards or in poster format for prominent display next to or on the machine. For consumer selectorized strength equipment, the instructions may take the

form of booklets, posters, or instruction placards, or may be a section of the owner's/user's manual.

**4.5.5 Installation Instructions**—Instructions shall be provided with selectorized strength equipment that indicate the minimum clearance required around each machine for access to and passage around the machine. These instructions shall provide specifications detailing the maximum dimensions of the machine at rest and during operation. The weight of the machine without the user shall also be provided. For consumer selectorized strength equipment, these instructions shall clearly state that the equipment shall not be used in a commercial setting.

**4.5.5.1** The dimensions stated in the installation instructions are the recommended minimum dimensions as set forth by the manufacturer. The actual area for access and passage shall be the responsibility of the facility and should take into account this training envelope and any required local codes or regulations.

**4.5.6 User Weight Restrictions:**

**4.5.6.1 Institutional Strength Equipment**—If the machine has been designed for users weighing less than 135 kg (300 lb), then the maximum user weight limits for the machine or each individual station, or both, shall be affixed to the machine where the user can easily read them.

**4.5.6.2 Consumer Strength Equipment**—The maximum user weight limits for the machine or each individual station, or both, shall be clearly stated in the owner's manual.

**4.6 Warnings**—Adequate warnings alerting users, third parties, and service personnel to hazards associated with selectorized strength training equipment shall be provided. These warnings shall be designed in accordance with Specification **F1749**.

**4.6.1 General Warning Label**—The general warning label for selectorized strength equipment shall be affixed to the machine in an area encountered by the user prior to use of the machine. The general warning label shall be designed in accordance with Specification **F1749** and include the following items. For consumer selectorized strength equipment, the notices in **4.6.1.2 – 4.6.1.6** may be omitted from the label, provided that they are included in the safety precautions portion of the owner's manual.

**4.6.1.1** Keep body, hair, and clothing free and clear of all moving parts.

**4.6.1.2** Inspect the machine before use. Alert to refrain from use if the machine appears damaged or inoperable. Alert to inspect all ropes, belts, or chains and their connections and refrain from use if any component is found to be worn or damaged.

**4.6.1.3** Alert to be certain that the weight pin is completely inserted (for selectorized strength equipment that employ weight stacks).

**4.6.1.4** Alert that the weight stack or top plate should never be pinned in an elevated position. Alert that a machine must never be used if found in this condition (for selectorized strength equipment that employ weight stacks).

**4.6.1.5** Alert to never use dumbbells or other means to incrementally increase the weight resistance other than those means provided by the manufacturer.

**4.6.1.6** Alert to never use the machine for support during stretching or to attach and use resistance straps, ropes, or other means.

**4.6.1.7** Alert to never allow children on selectorized strength equipment (unless the equipment is designed for the sole use of children) and to supervise the use of selectorized strength equipment by teenagers.

**4.6.1.8** Since reading and understanding all warnings and instructions contained in the owner's manual is essential to safe operation, consumer strength equipment shall contain in this label a statement advising the user to obtain, read, and understand the owner's manual prior to use.

**4.6.2 Site Specific Labels**—Site specific labels alerting users, third parties, and service personnel to the hazards specified in Specification **F1749** shall be provided.

**4.6.2.1** Site specific labels shall be placed near engagement, adjustment, or locator pin insertion points on institutional selectorized strength equipment alerting users to be certain that the engagement means is properly inserted. On consumer selectorized strength equipment these warnings shall be contained in the owner's manual.

**4.6.3 Marking**—Selectorized strength equipment shall have identification affixed to the machine indicating the following:

**4.6.3.1** Name and location of manufacturer.

**4.6.3.2** Serial and model numbers.

**4.6.3.3** Date of manufacture or code from which the month and year of manufacture can be determined.

**4.6.3.4** Classification of the machine if it is for consumer use only. For consumer selectorized strength equipment, this label must clearly state that the machine is not to be used in a commercial setting.

**4.7 Compliance**—Tests for compliance to the general requirements detailed in Section **4** will be conducted in accordance with the procedures detailed in Test Method **F2277**.

## **5. Keywords**

5.1 cam; selector pin; selectorized strength equipment; strength equipment; weight stack



**RELATED MATERIAL**

EN 957-1 Stationary Training Equipment—Part 1: General Safety Requirements and Test Methods<sup>3</sup>

EN 957-2 Stationary Training Equipment—Part 2: Strength Training Equipment, Additional Specific Safety Requirement and Test Methods<sup>3</sup>

---

<sup>3</sup> Available from CEN Management Centre, 36 rue de Stassart, B-1050, Brussels, Belgium.

*ASTM International takes no position respecting the validity of any patent rights asserted in connection with any item mentioned in this standard. Users of this standard are expressly advised that determination of the validity of any such patent rights, and the risk of infringement of such rights, are entirely their own responsibility.*

*This standard is subject to revision at any time by the responsible technical committee and must be reviewed every five years and if not revised, either reapproved or withdrawn. Your comments are invited either for revision of this standard or for additional standards and should be addressed to ASTM International Headquarters. Your comments will receive careful consideration at a meeting of the responsible technical committee, which you may attend. If you feel that your comments have not received a fair hearing you should make your views known to the ASTM Committee on Standards, at the address shown below.*

*This standard is copyrighted by ASTM International, 100 Barr Harbor Drive, PO Box C700, West Conshohocken, PA 19428-2959, United States. Individual reprints (single or multiple copies) of this standard may be obtained by contacting ASTM at the above address or at 610-832-9585 (phone), 610-832-9555 (fax), or [service@astm.org](mailto:service@astm.org) (e-mail); or through the ASTM website ([www.astm.org](http://www.astm.org)). Permission rights to photocopy the standard may also be secured from the Copyright Clearance Center, 222 Rosewood Drive, Danvers, MA 01923, Tel: (978) 646-2600; <http://www.copyright.com/>*