



Standard Specification for Ring, Bearing, Inner: for Needle Roller Bearing With Drawn Outer Ring¹

This standard is issued under the fixed designation F2163; the number immediately following the designation indicates the year of original adoption or, in the case of revision, the year of last revision. A number in parentheses indicates the year of last reapproval. A superscript epsilon (ϵ) indicates an editorial change since the last revision or reapproval.

This standard has been approved for use by agencies of the U.S. Department of Defense.

1. Scope

1.1 This specification covers inner rings for needle roller bearings with drawn outer rings.

1.2 The inner rings specified in this specification are intended for use on unhardened shafts in conjunction with open end needle roller bearings shown on Specification **F2162** and MS52141.

1.3 The use of recycled materials that meet the requirements of the applicable material specification without jeopardizing the intended use of the item is encouraged.

1.4 The inner rings specified in this specification are not intended for use in flight-critical systems of aircraft.

1.5 The values stated in inch-pound units are to be regarded as standard. The values given in parentheses are mathematical conversions to SI units that are provided for information only and are not considered standard.

NOTE 1—This specification contains many of the requirements of MS17130, which was originally developed by the Department of Defense and is currently maintained by the Defense Supply Center Richmond.

2. Referenced Documents

2.1 ASTM Standards:²

E18 Test Methods for Rockwell Hardness of Metallic Materials

F2162 Specification for Bearing, Roller, Needle: Drawn Outer Ring, Full Complement, Without Inner Ring, Open and Closed End, Standard Type

¹ This specification is under the jurisdiction of ASTM Committee F34 on Rolling Element Bearings and is the direct responsibility of Subcommittee F34.04 on Automotive/Industrial Bearing.

Current edition approved May 1, 2016. Published May 2016. Originally approved in 2001. Last previous edition approved in 2008 as F2163–01(2008) DOI: 10.1520/F2163-01R16.

² For referenced ASTM standards, visit the ASTM website, www.astm.org, or contact ASTM Customer Service at service@astm.org. For *Annual Book of ASTM Standards* volume information, refer to the standard's Document Summary page on the ASTM website.

2.2 ASME Standard:

ASME B 46.1 Surface Texture Surface Roughness, Waviness, and Lay³

2.3 SAE Standards:

SAE AHS STD-66⁴

SAE J-404 Chemical Composition of SAE Alloy Steels⁴

2.4 Military Standards:

MIL-STD-130 Identification Marking of US Military Property⁵

MS52141 Bearing, Roller, Needle: Drawn Outer Ring, Caged, Without Inner Ring, Open and Closed End, Standard Type⁵

2.5 American Bearing Manufacturer's Association (ABMA) Standard:

STD 4 Tolerance Definitions and Gauging Practices For Ball and Roller Bearings⁶

2.6 ISO Standard:

ISO 5593 Rolling Bearings—Vocabulary⁷

3. Terminology

3.1 *Definitions*—For definitions of terms used in this specification, refer to ABMA STD 4 and ISO 5593.

4. Ordering Information

4.1 When ordering parts in accordance with this specification, specify the following:

4.1.1 ASTM designation number, including year of issue;

4.1.2 Dash number (see **Table 1**); and

4.1.3 Dimensions of inner rings, including:

4.1.3.1 Bore diameter, in.;

4.1.3.2 Outside diameter, in.;

4.1.3.3 Width, in.; and

³ Available from Global Engineering Documents, 15 Inverness Way, East Englewood, CO 80112-5704, <http://www.global.ihs.com>.

⁴ Available from Society of Automotive Engineers (SAE), 400 Commonwealth Dr., Warrendale, PA 15096-0001, <http://www.sae.org>.

⁵ Available from USA Information Systems, 1092 Laskin Rd., Ste. 208, Virginia Beach, VA 23451.

⁶ Available from the American Bearing Manufacturer's Association, 1200 19th St. NW, Ste. 300, Washington, DC 20036–2401.

⁷ Available from American National Standards Institute (ANSI), 25 W. 43rd St., 4th Floor, New York, NY 10036, <http://www.ansi.org>.

TABLE 1 Inner Ring Dimensions

Dash Number	d Bore Diameter, in.			F Outside Diameter, in.			B Width, in.		r Radius, in.	Mating Bearings F2162 Dash Numbers ^A
	Nominal	Minimum	Maximum	Nominal	Minimum	Maximum	Minimum	Maximum		
-61	3/8	0.3745	0.3750	9/16	0.5620	0.5625	0.505	0.515	0.025	-16
-62	3/8	0.3745	0.3750	9/16	0.5620	0.5625	0.755	0.765	0.025	-17
-63	3/8	0.3745	0.3750	5/8	0.6245	0.6250	0.505	0.515	0.025	-18
-1	3/8	0.3745	0.3750	5/8	0.6245	0.6250	0.755	0.765	0.025	-19
-64	7/16	0.4370	0.4375	5/8	0.6245	0.6250	0.776	0.789	0.025	-19
-65	1/2	0.4995	0.5000	3/4	0.7495	0.7500	0.505	0.515	0.040	-22
-2	1/2	0.4995	0.5000	3/4	0.7495	0.7500	0.755	0.765	0.040	-23
-4	5/8	0.6245	0.6250	7/8	0.8745	0.8750	0.755	0.765	0.040	-26
-66	5/8	0.6245	0.6250	7/8	0.8745	0.8750	1.005	1.015	0.040	-27
-5	3/4	0.7495	0.7500	1	0.9995	1.0000	0.755	0.765	0.040	-29
-67	3/4	0.7495	0.7500	1	0.9995	1.0000	1.005	1.015	0.040	-30
-6	13/16	0.8120	0.8125	1	0.9995	1.0000	0.755	0.765	0.040	-29
-7	13/16	0.8120	0.8125	1	0.9995	1.0000	1.005	1.015	0.040	-30
-8	7/8	0.8745	0.8750	1 1/8	1.1245	1.1250	1.005	1.015	0.040	-33
-9	15/16	0.9370	0.9375	1 1/8	1.1245	1.1250	1.005	1.015	0.040	-33
-10	1	0.9995	1.0000	1 1/4	1.2495	1.2500	1.005	1.015	0.040	-35
-11	1	0.9995	1.0000	1 1/4	1.2495	1.2500	1.255	1.265	0.040	-36
-13	1 1/8	1.1245	1.1250	1 3/8	1.3745	1.3750	1.255	1.265	0.040	-40
-14	13/16	1.1870	1.1875	1 1/2	1.4995	1.5000	1.255	1.265	0.040	-43
-15	1 1/4	1.2495	1.2500	1 1/2	1.4995	1.5000	1.005	1.015	0.060	-42
-16	1 1/4	1.2495	1.2500	1 1/2	1.4995	1.5000	1.255	1.265	0.060	-43
-18	1 3/8	1.3745	1.3750	1 5/8	1.6245	1.6250	1.255	1.265	0.060	-45
-68	17/16	1.4370	1.4375	1 3/4	1.7495	1.7500	1.505	1.515	0.060	-48
-21	1 1/2	1.4995	1.5000	1 3/4	1.7495	1.7500	1.005	1.015	0.060	-47
-69	1 1/2	1.4995	1.5000	1 3/4	1.7495	1.7500	1.505	1.515	0.060	-48
-24	1 3/4	1.7495	1.7500	2 1/16	2.0620	2.0625	1.505	1.515	0.060	-72
-70	1 7/8	1.8745	1.8750	2 1/8	2.1245	2.1250	1.505	1.515	0.060	-54
-27	2	1.9995	2.0000	2 1/2	2.4995	2.5000	1.505	1.515	0.080	-57
-71	2 1/2	2.4995	2.5000	2 3/4	2.7495	2.7500	1.005	1.015	0.060	-59

^A Dash numbers for mating bearings as specified in 7.1.1 of F2162.

4.1.3.4 Radius, in.

5. Materials and Manufacture

5.1 Bearing inner rings shall be manufactured of steel, alloy or carbon, carburizing grade 4620, 4720, 8620, 8720, or 1018, 1022, or 1117 in accordance with SAE AHS STD-66 or SAE E52100 in accordance with SAE J-404.

6. Other Requirements

6.1 *Heat Treatment:*

6.1.1 Steel 4620, 4720, 8620, 8720, 1018, 1022, and 1117 shall be case hardened to Rockwell HRC58-65, in accordance with Test Methods E18. Case depth shall be 0.020 minimum.

6.1.2 Steel SAE 52100 shall be through hardened to Rockwell HRC58-65, in accordance with Test Methods E18.

6.2 *Protective Coating:*

6.2.1 Unless specified, plain (that is, not plated) inner rings shall be furnished.

6.2.2 Manufacturer shall coat inner rings with rust-preventative film.

6.3 *Lubrication:*

6.3.1 Oil hole(s), number (1 to 4) and size optional.

6.3.2 An oil groove, centered in the inner ring bore, is optional in accordance with manufacturer's standard practice.

7. Dimensions, Mass, and Permissible Variations

7.1 Products manufactured in accordance with this specification shall meet the requirements shown in Table 1.

7.1.1 Given the shaft diameter and radial load for a particular bearing application, the bore diameter of the inner ring is selected from the shaft size. The outer diameter and width are chosen by dimensionally mating the inner ring with the outer ring (see Specification F2162 or MS52141) that exhibits the required load capacity.

7.2 The taper in the shaft shall not exceed 0.0003 in. per inch of bearing length.

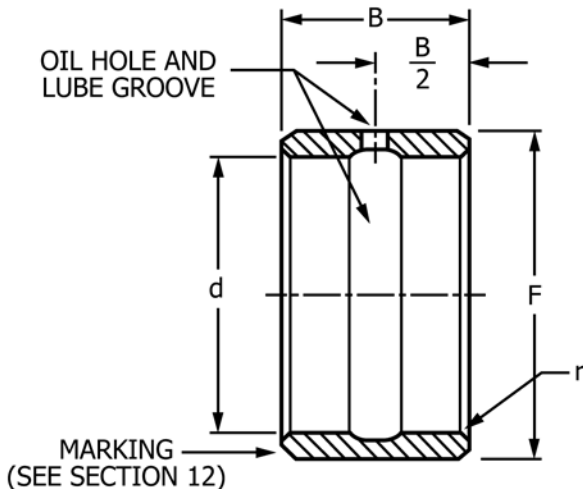

FIG. 1 Schematic Drawing of Inner Ring

7.3 The inner ring must clear the maximum shaft fillet radius shown in the radius column of **Table 1**. The radii or chamfers on the inner diameter of the ring may be unequal. Where the radii are unequal, the surface with the larger relief should be mounted against the shaft shoulder.

8. Workmanship, Finish, and Appearance

8.1 *Surface Finish*—The raceway (outside diameter) surface shall have a maximum surface roughness in accordance with ASME B46.1 of 20 μm . Ra.

9. Inspection

9.1 Inspection of the product shall be agreed upon between the purchaser and the supplier as part of the purchase contract.

10. Rejection and Rehearing

10.1 Products that fail to conform to the requirements of this specification may be rejected. Rejection should be reported to the producer or supplier promptly and in writing. In case of dissatisfaction with the results of the test, the producer or supplier may make claim for rehearing.

11. Certification

11.1 When specified in the purchase order or contract, the purchaser shall be furnished certification that samples representing each lot have been either tested or inspected as directed in this specification and the requirements have been met. When specified in the purchase order or contract, a report of the test results shall be furnished.

12. Product Marking

12.1 Marking shall consist of the part number and the manufacturer's identification in accordance with MIL-STD 130.

12.2 On inner rings where the inside diameter relief radii are not equal, the marking shall appear on the surface with the lesser radius.

12.3 The part number shall consist of the MS17130 designation number plus the dash number (see **Table 1**).

13. Keywords

13.1 drawn outer ring; inner ring; MS 17130 ; needle roller bearing

ASTM International takes no position respecting the validity of any patent rights asserted in connection with any item mentioned in this standard. Users of this standard are expressly advised that determination of the validity of any such patent rights, and the risk of infringement of such rights, are entirely their own responsibility.

This standard is subject to revision at any time by the responsible technical committee and must be reviewed every five years and if not revised, either reapproved or withdrawn. Your comments are invited either for revision of this standard or for additional standards and should be addressed to ASTM International Headquarters. Your comments will receive careful consideration at a meeting of the responsible technical committee, which you may attend. If you feel that your comments have not received a fair hearing you should make your views known to the ASTM Committee on Standards, at the address shown below.

This standard is copyrighted by ASTM International, 100 Barr Harbor Drive, PO Box C700, West Conshohocken, PA 19428-2959, United States. Individual reprints (single or multiple copies) of this standard may be obtained by contacting ASTM at the above address or at 610-832-9585 (phone), 610-832-9555 (fax), or service@astm.org (e-mail); or through the ASTM website (www.astm.org). Permission rights to photocopy the standard may also be secured from the Copyright Clearance Center, 222 Rosewood Drive, Danvers, MA 01923, Tel: (978) 646-2600; <http://www.copyright.com/>