



Standard Guide for Construction and Maintenance of Skinned Areas on Baseball and Softball Fields¹

This standard is issued under the fixed designation F2107; the number immediately following the designation indicates the year of original adoption or, in the case of revision, the year of last revision. A number in parentheses indicates the year of last reapproval. A superscript epsilon (ϵ) indicates an editorial change since the last revision or reapproval.

1. Scope

1.1 This guide covers techniques that are appropriate for the construction and maintenance of skinned areas on baseball and softball fields. This guide provides guidance for the selection of materials, such as soil, sand, gravel, crushed stone, crushed brick, calcined clay, calcined diatomaceous earth, vitrified clay, etc., for use in constructing or reconditioning skinned areas and for the selection of management practices that will maintain a safe and playable skinned surface. Although this guide is specific to baseball/softball, it has application to other sports where ball bounce, ball roll, or player footing, or a combination thereof, are of importance.

1.2 Decisions in selecting construction and maintenance techniques are influenced by existing soil types, climatic factors, level of play, intensity of use, equipment available, budget, and training and ability of management personnel.

1.3 The values stated in SI units are to be regarded as the standard. The values in parentheses are for information only.

1.4 *This standard may involve hazardous materials, operations, and equipment. This standard does not purport to address all of the safety concerns, if any, associated with its use. It is the responsibility of the user of this standard to establish appropriate safety and health practices and determine the applicability of regulatory requirements prior to use.*

1.5 *This guide offers an organized collection of information or a series of options and does not recommend a specific course of action. This document cannot replace education or experience and should be used in conjunction with professional judgment. Not all aspects of this guide may be applicable in all circumstances. The ASTM standard is not intended to represent or replace the standard of care by which the adequacy of a given professional service must be judged, nor should this document be applied without consideration of a project's many*

unique aspects. The word “Standard” in the title of this document means only that the document has been approved through the ASTM consensus process.

2. Referenced Documents

2.1 *ASTM Standards:*²

[C33 Specification for Concrete Aggregates](#)

[C242 Terminology of Ceramic Whitewares and Related Products](#)

[D422 Test Method for Particle-Size Analysis of Soils \(Withdrawn 2016\)](#)³

[D653 Terminology Relating to Soil, Rock, and Contained Fluids](#)

[D5883 Guide for Use of Rotary Kiln Produced Expanded Shale, Clay or Slate \(ESCS\) as a Mineral Amendment in Topsoil Used for Landscaping and Related Purposes](#)

[E11 Specification for Woven Wire Test Sieve Cloth and Test Sieves](#)

[F405 Specification for Corrugated Polyethylene \(PE\) Pipe and Fittings \(Withdrawn 2015\)](#)³

[F1632 Test Method for Particle Size Analysis and Sand Shape Grading of Golf Course Putting Green and Sports Field Rootzone Mixes](#)

[F2270 Guide for Construction and Maintenance of Warning Track Areas on Athletic Fields](#)

3. Terminology

3.1 *Definitions*—Except as noted, soil related definitions are in accordance with Terminology [D653](#).

3.1.1 *calcined clay*—granular, lightweight material produced by calcining clay minerals, such as montmorillonite and attapulgite, at temperatures of about 700°C or higher. Those used as soil amendments should be hard, resistant to physical breakdown, and screened to appropriate sizes. Calcined clay is

¹ This guide is under the jurisdiction of ASTM Committee F08 on Sports Equipment, Playing Surfaces, and Facilities and is the direct responsibility of Subcommittee F08.64 on Natural Playing Surfaces.

Current edition approved Dec. 1, 2015. Published February 2016. Originally approved in 2001. Last previous edition approved in 2008 as F2107–08. DOI: 10.1520/F2107-08R15.

² For referenced ASTM standards, visit the ASTM website, www.astm.org, or contact ASTM Customer Service at service@astm.org. For *Annual Book of ASTM Standards* volume information, refer to the standard's Document Summary page on the ASTM website.

³ The last approved version of this historical standard is referenced on www.astm.org.

a manufactured product that lacks the particle size and plasticity properties that would allow it to be included in the definition of clay. **(1)⁴**

3.1.2 *calcined diatomite*—stable, lightweight granules produced by calcining diatomite (diatomaceous earth), a hydrated silica mineral derived from the remains of diatoms. **(1)**

3.1.3 *clay*—clay can be defined in terms of a particular size fraction of a soil, a soil textural class, a soil particle size class, a soil textural group, soil mineralogy, or, in engineering terms, as materials that exhibit plastic soil properties when at appropriate water contents.

3.1.3.1 *Discussion*—Ideally, the term “clay” should be appropriately defined when used to describe soils for skinned infield mixes. For example, a 60 % sand/40 % clay mixture could imply either 60 % sand/40 % clayey soil (or other soils with textures containing enough clay (<0.002 mm) to exhibit plasticity) or 60 % sand (2 to 0.05 mm)/40 % clay (<0.002 mm).

3.1.3.1 *clay*—(1) as a particular size fraction of a soil, a soil separate consisting of particles <0.002 mm (fine earth fraction) in equivalent diameter. (2) as a textural class, soil material that contains 40 % or more clay, <45 % sand and <40 % silt. (3) as a soil particle size class, soil material that contains 35 % or more clay, (clayey soils). (4) as a soil textural group, soil material that falls within the textural classes of “sandy clay,” “silty clay” and “clay” (clayey soils). (5) in terms of mineralogy, soil particulates that are commonly occurring but not restricted to the <0.002 mm fraction (clay minerals). Commonly occurring in soil mineralogy classes as smectitic, kaolinitic, illitic (micaceous), gibbsitic, ferritic, or mixed. Soil mineralogy classes are defined predominantly by the type of soil mineral dominating (40 % or more) the fine earth fraction. (6) in engineering terms, soils containing enough soil material in the less than 0.4 mm fractions such that when moist they exhibit consistence characteristics of “moderately plastic” or “very plastic” forming a roll 4 cm or longer and 4 mm or thinner that supports its own weight. **(2-7)**

3.1.4 *vitrified clay*—clay that has been manufactured through vitrification, which is the progressive reduction and elimination of porosity of a ceramic composition, with the formation of a glass phase, as a result of a heat treatment. **C242**

3.1.5 *expanded shale, clay, or slate (ESCS)*—a rotary kiln produced vesicular amorphous silicate particulate material. It is a highly porous, low density material with an apparent specific gravity of approximately 0.8 to 2.4, and a dry/loose unit weight of approximately 35 to 70 lb/ft³ (561 to 1121 kg/m³). **D5883**

3.1.6 *sand*—sand can be defined in terms of a particular size fraction of soil, a soil textural class, a soil particle size class, and a soil textural group.

3.1.6.1 *sand*—(1) as a particular size fraction of soil, a soil separate consisting of particles >0.05 mm and <2.0 mm in equivalent diameter. (2) as a textural class, soil material that contains 85 % or more sand, and not more than 10 % clay. (3)

⁴ The boldface numbers in parentheses refer to the list of references at the end of this standard.

as a soil particle size class, soil material that contains 70 % or more sand, and not more than 15 % clay (sandy soils). (4) as a soil textural group, soil material that falls within the textural classes of “sand” and “loamy sand” (sandy soils). **(3,4)**

3.1.6.1 *Discussion*—Although no mineralogy term is associated with the definition of sand, common usage often utilizes the terms “quartz” or “silica” as synonyms for sand. While quartz is the most common silicate mineral in soils and in the sand fractions in particular, quartz being a mineral highly resistant to weathering, the synonymy with the term sand is incorrect. A proper mineralogy class for quartz is “siliceous,” defined as 90 % or more of the 0.2 to 2.0 mm fraction composed of silica minerals (quartz, chalcedony, or opal) and other extremely durable minerals that are resistant to weathering. **(4)**

3.1.7 *gravel*—commonly used to denote spherical, cube-like, or equiaxial aggregate materials with an equivalent diameter >2.0 mm and <7.6 mm. More correctly used, this classification refers to “rock fragments” classified as pebbles in the Glossary of Soil Science Terms (1997). **(3,6)**

3.1.8 *skinned area*—area on sports fields that, by design, is devoid of turfgrasses or other vegetation; may be entire field or a portion of the field (for example, skinned infield in baseball or softball; skinned base paths in otherwise turfed infield). Pitching mounds and catcher’s and batter’s boxes are also considered skinned areas. Warning tracks (Guide **F2270**) can be considered skinned areas as well.

3.1.9 *soil*—sediments or other unconsolidated accumulations of solid particles produced by the physical and chemical disintegration of rocks, and which may or may not contain organic matter.

3.1.10 *soil profile*—vertical section of a soil, showing the nature and sequence of the various layers, as developed by deposition or weathering or both or as developed by construction procedures.

3.1.11 *soil texture* (gradation) (grain-size distribution)—the proportions by mass of a soil or fragmented rock distributed in specified particle size ranges.

3.1.11.1 *soil textural class*—texture designation based on relative proportions of the various soil separates: sand (2.0 to 0.05 mm in diameter), silt (0.05 to 0.002 mm), and clay (<0.002 mm). **(2-7)**

NOTE 1—Particle size ranges for sand, silt, and clay as listed above vary somewhat from ranges given in Test Method **D422** and Terminology **D653**.

4. Significance and Use

4.1 The skinned areas of baseball and softball fields should provide a uniform playing surface of high quality. Ball bounce should be true and predictable. Footing and sliding properties should favor optimum performance of players. Undulations, rough surface, hard or soft surfaces, weeds, stones, and wet spots detract from good play. Playing surface quality is largely affected by construction and maintenance procedures, and this standard guide addresses those procedures. While warning tracks are a type of skinned area found on baseball and softball fields, this standard does not apply to warning tracks. A

separate standard, Guide **F2270**, presents information pertaining to warning tracks.

4.1.1 During construction, consideration should be given to factors such as the physical and chemical properties of materials used in the area, freedom from stones and other debris, and surface and internal drainage.

4.1.2 Maintenance practices that influence the playability of the surface include edging, dragging, rolling, watering, vegetation control, brushing or hosing to prevent buildup of a lip of mineral matter in turfgrass at the skinned/turfed edges, and removal of stones and debris that may adversely affect play and safety.

4.2 Those responsible for the design, construction, or maintenance, or a combination thereof, of skinned areas on baseball and softball fields will benefit from this guide.

4.3 This guide provides flexibility in choices of procedures and can be used to cover a variety of use and budget levels.

5. Construction

5.1 Skinned Infield and Basepath Areas:

5.1.1 *Skinned Infield Mix*—Materials used to provide the skinned surface should be relatively inert mineral matter, which will resist chemical and physical degradation. This soil or mixture is sometimes referred to as “dirt,” for example, infield dirt. It is used in constructing skinned infields and basepath areas.

5.1.2 *Particle Size Distribution*—Particle size analyses (Test Method **D422** or **F1632**) are based on oven-dried mass of a weighed sample; shaker is the preferred method of dispersion if the skinned infield mix contains internally porous amendments. Such analyses are satisfactory when the skinned infield mix consists of sand and soil materials; however, analysis based on mass can give misleading results if the skinned infield mix contains internally porous amendments.

5.1.2.1 Native Soil Skinned Areas:

(1) Depending on the soil texture, some existing or native soils containing greater than 70 % sand (2.0 to 0.05 mm) may be satisfactory in skinned areas; however, some soils will need to be modified to improve drainage and ease of soil grooming. Additions of coarse amendments (sand, calcined mineral (clay or diatomite), expanded shale, clay or slate, vitrified clay or combinations in appropriate amounts (dependent on textural class of soil being modified)) should increase permeability, and improve the overall aesthetics of the surface after grooming. Added sand or calcined materials should have a minimum of 85 % of the particles passing a 4.0 mm (No. 5) sieve and retained on a 106 μm (No. 140) sieve. Quartz sands are recommended; if sand contains more than 5 % calcium carbonate equivalent, the sand has the potential for particle cementation due to dissolution and precipitation. If additions will increase the grade to an unacceptable elevation, remove appropriate amounts of soil prior to the addition of coarse amendments. The final mixture should have approximately 90 to 100 % of the particles passing a 4.0 mm (No. 5) sieve and 15 to 30 % passing a 106 μm (No. 140) sieve. In final raking and grading, remove all debris and stone greater than 1 cm in diameter from the surface 1.5 cm. The settled depth of the modified soil should be about 10 cm.

(2) Modification of an existing soil should be done during construction of the facility. In some recreational baseball/softball situations, consideration of skinned areas occurs only after a turfgrass stand is worn down to the soil surface. Layout and modification of skinned areas can take place at that time and will require taking the field out of play unless the work is done after the playing season.

5.1.2.2 Artificial (Man-made) Skinned Areas:

(1) Artificial (man-made) profiles are sometimes constructed to create the skinned area. In situations where profiles contain more than 85 % sand and exhibit high internal permeability under heavy compaction, the skinned infield mix can be placed on a drainage blanket of gravel, which provides subsurface drainage. In situations where profiles contain less than 85 % sand and exhibit limited internal permeability under heavy compaction, a drainage blanket of gravel is not required, as subsurface drainage will be minimal. Skinned infield mixes of this nature may be placed directly on top of the subsoil. Additional information regarding the construction of skinned infield areas with subsurface drainage systems is found in the appendix.

(2) *Skinned Infield Mix*—A skinned infield mix can be used to bring the surface to final grade. Add approximately 10 to 15 cm (4 to 6 in.) of skinned infield mix and finish to final grade. Skinned infield mix materials should meet the following particle size specifications. Quartz sands are recommended; if sand contains more than 5 % calcium carbonate equivalent, the sand has the potential for particle cementation due to dissolution and precipitation.

Standard	Sieve Designation (E-11)		Skinned Infield Mix % passing
		Alternate	
2.00 mm	No. 10		85-100
1.00 mm	No. 18		62-90
500 μm	No. 35		48-84
250 μm	No. 60		38-71
150 μm	No. 100		27-60
53 μm	No. 270		19-40

(a) Management of the surface will be affected by the amount of material <53 μm (<0.05 mm, silt and clay). As this fraction decreases, the area will be more permeable but will retain less water. Management requirements based on this fraction will be affected by the relative proportion of silt to clay and the type of clay. The presence of clay is desirable from the standpoint of providing both a firm and stable surface for good footing. Clays that are oxides and hydroxides of iron and aluminum are less cohesive, sticky, and plastic than silicate (layer silicate) clays. Smectitic clays (for example, montmorillonite) are silicate clays that have the highest cohesive, plastic, and shrink/swell properties. Illitic clays (fine-grained mica clay) are characterized by a much lower expression of these properties than found in smectites. Cohesion, swelling, shrinkage, plasticity, and stickiness properties of kaolinitic clays are lower than smectitic and illitic clays. The order of decreasing cohesiveness and plasticity are as follows: Smectitic, Illitic, Kaolinitic, Quartz. Because of differences in the physical properties of different clay types and variations in total clay that can occur in the suggested particle size specification for a skinned infield mix, adjustments to these specifications may be appropriate in some cases.

(b) In general, skinned infield mixes with less than 19 % in the <53 μm (<0.05 mm) fraction are better suited in rainy climates due to greater internal drainage. In dry periods, they may require additional irrigation to minimize dust and to provide a firm surface. Skinned infield mixes with greater than 19 % in the <53 μm (<0.05 mm), will drain more slowly but will retain more water. Frequency of irrigation will be less. These mixes will be more cohesive and will be more difficult to loosen when they compact.

(c) If the performance of a skinned infield mix is not totally satisfactory after installation, its physical composition can be altered by incorporating sand or amendments to loosen it or by adding clayey soil to create a firmer mix. Such alterations may be related to player preference or to ease of maintenance.

(d) For baseball/softball areas, it is desirable to have a firm, moist mix with a loose 6 to 7 mm cap over the entire area. This cap, comprised of loosened skinned infield mix or a mixture of sand or amendment and the skinned infield mix, should allow for uniform ball bounce and roll to occur, as well as provide a good surface for sliding. It also gives players material to repair divots or other imperfections that may occur during the game. An advantage to using stable, lightweight amendments in this surface layer is their relatively high water retention properties. Their internal porosity can absorb moisture from light rain and help to keep the surface at a consistency favorable for play.

(e) Color of the skinned infield mix may be of concern aesthetically (for example, contrast of adjoining turf color with skinned infield mix color); however, functional qualities should also be considered. White markings of foul lines, boundaries, etc. are more distinct on darker surfaces. Reflectivity of light is less on darker surfaces. In general, the soil/clay component in these mixes will impart a brownish, reddish, or yellowish color. Avoid white or very lightly colored top mixes that can cause excessive glare.

(3) *Placement and Grading of Skinned Infield Mix*—Dump materials at the edge of area and use tracked equipment to spread them onto the area. Roll skinned infield mix to obtain a firm, but not severely compacted, surface. Establish surface grade of 1 to 1.5 %, or as specified by rules of a sport. Slope may be established by crowning the field or by having the grade uniform across the field. Slope should continue at least 3 m beyond side lines. On baseball or softball infields, slope should be away from the pitchers mound to the outfield grass and extend at least 3 m beyond the foul lines and home plate. Water running off the field to a low point should be directed away from the sidelines to a natural or constructed drainage swale or be removed by vertical drain trenches (slit trenches) backfilled with gravel or other coarse material, prefabricated channel drains, or, if well off the playing field including sideline and foul areas, catch basins.

(4) Crushed brick, screenings (fines, most of which will pass a No. 8 (2.36 mm) sieve) created when rocks, boulders, etc. are artificially crushed, cinders, and slag are alternative materials used on some areas to create a skinned surface. When such materials are used, particle sizes should be appropriate for

providing a firm, stable playing surface. Because sharpness of particle edges may occur as a result of the manufacturing process, limit the inclusion of particles greater than 2 mm to minimize abrasions.

5.2 *Pitcher's Mound, Batter's Box, and Catcher's Box:*

5.2.1 *Particle Size Distribution*—A fine-textured soil, containing more than 35 % clay (<0.002 mm), is used to establish a stable, wear-resistant surface that will be exposed to the foot traffic of pitchers, catchers, and batters. Such materials are sometimes mixed with an infield mix to provide firmer base paths.

5.2.2 *Pitcher's Mound*—Excavate to 20 to 30 cm (8 to 12 in.). Construct mound by alternately adding 5 to 7.5 cm (2 to 3 in.) of mound mix (“mound clay”) and tamping. Moisten “clay” as required to allow ease of compaction. Continue additions and tamping until required dimensions of mound are obtained. Materials used for mound construction include clay products in the forms of moist, loose packing clay, moist bricks of clay, and dry, granular material that must be moistened prior to packing (tamping). A very firm footing area is essential for the front half (landing area) of a pitching mound. Less firm, but stable, materials may be used on the sides and back of the mound. When construction is completed, lightly topdress the mound with skinned infield mix, sand, calcined amendments, or a combination of these materials.

5.2.3 *Batter's Boxes and Catcher's Box*—Excavate to 20 to 30 cm (8 to 12 in.). Add “clay” as described in 5.2.2 until 2.5 to 5 cm (1 to 2 in.) below desired final grade. Fill to surface with skinned infield mix or a mixture of “clay” and top mix, moisten as needed, tamp.

NOTE 2—Packing clays, clay blocks or bricks, and unfired bricks used to construct mounds and batter's and catcher's boxes can vary in type of clay (for example, illite, kaolinite) and amount of clay (<0.002 mm); however, when at proper water content, all of these materials exhibit the plasticity and strength properties required on these areas.

5.3 *Base Paths*—They are generally comprised of the skinned infield mix used on the rest of the infield. If a firmer or looser path is desired, an appropriate soil, sand, or amendment can be mixed into these areas.

5.4 *Water*—In that adequate soil water content is needed to obtain desired firmness and dust control on all skinned areas, it is recommended that new installations provide a means of watering the surface, for example, irrigation system or hydrants of sufficient capacity to allow for efficient watering of the surface. On a baseball infield, consider locating a quick coupler valve about 3 m directly behind the pitcher's mound. This location is the least impacted area on the field and this is the safest and most logical place to put the valve. The valve box should be slightly below grade. Other good locations for quick coupler valves used to maintain the infield are at the back of the infield arc outside the foul lines.

6. Maintenance

NOTE 3—It has often been observed that the skills of the grounds manager are a greater contributing factor to high quality skinned areas than the materials used to construct these areas. Successful grounds managers must select management practices that are appropriate for the field at hand, or modify field conditions to match a given maintenance program.

6.1 Water:

6.1.1 *Soil Water Content*—Skinned areas need moisture to maintain proper consistency. If allowed to dry, these areas become dusty, powdery, or rock hard. Footing is poorer when sandy top mixes become dry or less stable. When necessary, water the area to maintain desired soil water content in the skinned infield mix. If surface becomes dry, use light watering prior to use to keep dust down. Watering will also decrease hardness of clayey mixes and increase cohesiveness of sandy mixes. When budget allows, tarpaulins may be used to prevent excessive wetting due to rainfall. Soil water content is critical on pitcher's mounds and batter's and catcher's boxes. Footing is adversely affected when "clay" on these areas becomes too wet or dry. Drying may cause cracking of the soil. Thus, these areas should be covered with an appropriate impervious cover when not in use. Such covers prevent evaporation in dry weather and protect the area from excess water during rainfall or general irrigation of an infield. Use hand watering on these areas when water content must be increased. Should these areas become wet and slippery, a calcined clay or diatomite, skinned infield mix, sand, or vitrified clay can be used to alter surface conditions if there is not time for natural drying without a cover.

6.1.2 *Standing Water*—If rain or irrigation water accumulates in surface depressions, use a soil sampling probe, auger, spading fork, or other tool to create vertical channels through the skinned infield mix and into the pervious layers below. Other methods to remove standing water include channeling to a lower area off the field of play, digging a hole in the deepest spot and bucketing out the water, using a puddle pump, using a squeegee (either hand or power operated), and by two people pulling a water-filled one-inch hose across the area to pull water to another area. After standing water is removed, loosen the surface with a rake, nail drag, or other scarifying tool to hasten drying by evaporation. Sand or water absorbing amendments can be scratched into the surface at this time. If water is shallow, various water absorbing materials can be added to the area. Remove any absorbents that are not compatible with the skinned infield mix. Generally, calcined clay, diatomaceous earth or vitrified clay can be left on the area and are mixed with existing skinned infield mix during subsequent grooming of the surface. Eliminate depressions by filling or grading, or both.

6.2 *Dragging and Grooming*—In order to maintain a level surface on skinned areas, periodic dragging and grooming is necessary. Loosening, leveling, and grooming can be accomplished using one of several commercially available infield groomer/conditioner machines or by using drags that are pulled either by hand or light equipment such as a small tractor or utility vehicle. In general, dragging operations fall into three categories: scarifying, leveling, and grooming. Each of these operations may be done with a separate drag or a combination machine. For each type of drag, operating at a slow, even speed will be most effective.

NOTE 4—A list of commercial products is available from the Sports Turf Managers Association, see Resource 1 in X3.1.

6.2.1 Scarifier drags are designed to scratch and loosen the soil. They can be used to relieve surface compaction, assist in drying wet soil, decrease hardness, create the loose 6 to 7 mm

cap of material on skinned infields, and mix and incorporate soil amendments. Moist soils allow deeper penetration than dry soils; however, the conditioning effect is adversely affected if soils are too wet. Depth of penetration can be altered by changing the weight placed on a drag. Scarifier drags can be constructed using construction lumber and 40 penny nails (approximately 12.7 cm or 5 in. long). One plan for a homemade nail drag is shown in the appendix. More elaborate metal framed, steel tined drags can be constructed as well.

6.2.2 Leveling drags are designed to level the surface by cutting off humps and filling depressions, and usually consist of a long (1.8 to 3.6 m; 6 to 12 ft) narrow length of rigid heavy lumber or metal. The drag should be long enough to bridge depressions, such as those created in sliding areas of infields. A 2.4 to 3.0 m (8 to 10 ft) leveling drag can bridge low and high spots on an infield while remaining fairly manageable for one person to pull. A 5 to 10 cm (2 to 4 in.) high plate along the front edge of the drag will allow soil to be moved and deposited when the drag is pulled by hand or with small equipment. A leveling drag should always be set at a slight angle to the path of travel so that collected soil can move to the trailing end. Pulling at an angle will also prevent the drag from bouncing and creating a washboard effect.

6.2.3 Grooming drags are used to give the final touch to a skinned surface. They normally consist of metal link-mat, fiber mat, or carpeting. Being lighter in weight than scarifier and leveling drags, they displace very little soil but do smooth and level slight imperfections from foot traffic or other dragging operations. The dimensions of grooming drags varies, but those that are 1.8 to 2.4 m (6 to 8 ft) wide and 0.6 to 1.8 m (2 to 6 ft) long have proven to be very effective for field grooming.

6.2.4 Dragging patterns are dependent on the extent of the skinned area (i.e., some infields are completely skinned while others contain turfgrass as well as skinned areas). Where infield grass is present, the skinned area can be dragged using long semi-circular passes between the infield and outfield grass. This area can also be dragged using a circular spiral path with a diameter of approximately 3 m (10 ft). When using circular or oval patterns, alternate operating in clockwise and counter-clockwise directions. The use of alternate dragging patterns helps to prevent the development of low and high spots. Keep 15 cm (0.5 ft) away from grass surfaces to prevent depositing soil on the grass surface. Missed areas can be loosened and groomed by hand raking and brushing. Empty soil collected on a drag onto the skinned portion, not onto the grass.

6.3 *Soil Buildup at Turfgrass-Skinned Area Boundary*—The mound or ridge that often exists between the turf and soil areas is commonly referred to as a "lip." These lips present a very unsafe condition and must be addressed even under minimum maintenance practices. As well as causing unpredictable ball bounce, lips create a safety hazard due to bad bounces and uneven surfaces underfoot. Lips can also impede surface drainage of water from skinned areas. Lip buildup can occur due to improper dragging, wind or water erosion of soil in the skinned area, and movement of soil due to foot traffic or sliding.

6.3.1 To prevent or minimize lip buildup, soil deposited in the edge of the turf can be brushed or washed back onto the

skinned area. As a lip begins to accumulate, a rigid-tooth rake can be used for removal. A hose equipped with a high pressure nozzle can also be used; however, this method should be used only when the surface can dry before the next use of the field.

6.3.2 If a lip is substantial and not easily removed by the above methods, other approaches are: (1) stripping the sod containing the lip, removing soil material to reestablish the grade, and resodding with the old or new sod, or (2) removal of soil material in the lip using multiple passes of coring equipment commonly used in turfgrass management, removal of cores from the site, and rolling to compress the raised area. A similar method is to dig a narrow v-shaped trench next to the lip and then compress the raised lip into the trench.

6.4 *Renovation*—If the surface becomes too compact, resulting in poor internal drainage and too hard a playing surface, till the surface, add additional skinned infield mix or amendments, or both, regrade, and groom. Most infields require renovation at least annually, usually after completion of the playing season. Tillage may occur in the fall or winter and final grading in early spring.

6.5 *Weed Control*—Weed invasion of skinned areas can adversely affect the playing surface. Vegetation that encroaches on these areas can be removed by physical means or by herbicides. Timely grooming should eliminate any vegetation. Personnel at cooperative extension offices can provide assistance in diagnosing and correcting weed problems. Should

herbicides be required, a nonselective material with no residual effect should be used (for example, glyphosate). Herbicides should be used in compliance with label information and local, state, and federal laws and regulations.

6.6 *Inspection*—Inspect field prior to each use. Remove foreign material that could affect playability and safety of the field. Also, fill ruts or holes that could affect playability and safety.

7. Report

7.1 Reports dealing with construction should include drawings related to layout, soil profile, drainage system, irrigation system, etc.; results of physical analyses on gravel, skinned infield mix, and materials used in constructing pitcher's mounds and batter's/catcher's boxes; chronological accounting of construction procedures; and a list of all materials used.

7.2 Reports dealing with maintenance should include dates and details of each management procedure. List all materials used, and, in the case of pesticides, include copies of records maintained as required by governmental regulations. A summary should indicate time and materials allocated to each procedure during and after the playing season.

8. Keywords

8.1 athletic field; baseball; clay; skinned area; softball; soil; sports field

APPENDIXES

(Nonmandatory Information)

X1. CONSTRUCTION OF SKINNED INFIELD MIXES WITH SUBSURFACE DRAINAGE SYSTEMS

X1.1 In situations where profiles contain more than 85 % sand and exhibit high internal permeability under heavy compaction, the skinned infield mix can be placed on a drainage blanket of gravel, which provides subsurface drainage. A false (perched) water table is formed at the interface of the skinned infield mix and the gravel because water will not move from the finer pores of the skinned infield mix into the larger pores of the gravel layer until the water content in the skinned infield mix is at or near saturation at the interface. This condition helps to maintain a moist condition in the skinned infield mix. Because of the particle size differential between the skinned infield mix and gravel, an intermediate layer may be placed on the gravel to prevent inwashing of the skinned infield mix. In cases where the subgrade has sufficient permeability, the skinned infield mix can be placed directly on the subgrade.

X1.2 Steps in constructing a skinned area with a gravel drainage blanket follow:

X1.2.1 Excavate to a depth equal to the depth of settled layers within the profile (approximately 35 to 45 cm). Firm the subgrade to minimize settlement.

X1.2.2 Excavate trenches (approximately 20 cm wide and 20 cm deep) in the subgrade for drainage pipe (lateral and main lines), with no more than 10 m between laterals. Remove excavated material or spread evenly over subgrade between trenches. Corrugated perforated plastic drainage pipe (tubing) having a diameter of approximately 10 cm and conforming to Specification F405 is recommended. Non-perforated pipe can be used outside the drainage area to carry water to a suitable storm drain or surface drainage area.

X1.2.3 Place drainage pipe on a 5 to 10 cm bed of gravel in the trenches. Minimum grade for drainage pipes is 1.0 %. Use laser or other appropriate equipment to maintain accurate grades.

X1.2.4 Cover drainage pipe and subgrade with a 7 to 10 cm layer of washed gravel or crushed rock. Gravel should consist of hard durable particles of natural gravel or crushed rock or stone that will not degrade when alternately wetted and dried or frozen and thawed. Do not use soft or easily weathered materials in this layer. The particle size of the gravel should meet the following specifications:

90 to 100 % (weight basis) passing 12.5 mm (0.5 in.) sieve
 Minimum of 50 % passing 9.5 mm (0.375 in.) and retained on 6.3 mm (0.25 in.) sieve
 Maximum of 10 % passing 2.36 mm (No. 8) sieve
 Uniformity coefficient: $D_{90}/D_{10} \leq 3$ (D_{90} and D_{10} refer to the diameter below which 90 % and 10 % of the particles fall, as determined from a particle size accumulation curve)
 Coarse aggregates of size numbers 7 and 8 (Specification C33) should receive consideration

X1.2.4.1 Grading requirements for these materials follows:

Sieve Designation (E-11)	Alternate	Size 7	Size 8
Standard		% Passing	
19.0 mm	0.75 in.	100	—
12.5 mm	0.50 in.	90 to 100	100
9.5 mm	0.375 in.	40 to 70	85 to 100
4.75 mm	No. 4	0 to 15	10 to 30
2.36 mm	No. 8	0 to 5	0 to 10
1.18 mm	No. 16	—	0 to 5

X1.2.5 If an intermediate layer is used, place intermediate layer of 5 to 7 cm thickness on the gravel layer. Material in this layer should have 90 % of the particles between 1 and 4 mm.

X1.2.6 If budget restraints prohibit the installation of a gravel and pipe drainage system, (1) excavate drainage trenches (approximately 20 cm wide and 20 cm deep) on not greater than 5 m centers in the subgrade, install drainage pipe on a 5 to 10 cm bed of gravel, and backfill trenches with gravel to the subgrade surface; or (2) excavate drainage trenches (approximately 10 to 20 cm wide and 20 cm deep) on not greater than 5 m centers, and backfill trenches with gravel to the subgrade surface (prefabricated drains wrapped in geotextile fabric may be utilized in this system). With each method excavated material should be removed or spread evenly on the subgrade and provisions for removing subsurface drainage water from the site should be provided. Maintain a minimum grade of 1.0 % in pipe or trenches described in this section.

X1.2.7 Add a sufficient amount of skinned infield mix to obtain the desired final grade.

X2. NAIL DRAG DIAGRAM

X2.1 Made with 2 by 4 in. treated lumber for base. Need three 3-ft sections and three 5-ft sections.

X2.2 Use three 5-ft sections of 1 by 4 in. board on top of drag to cover the 2 by 4 in. base where nails have been inserted (hold nails in).

X2.3 Pre-drill straight holes for nails (use 40 penny nails).

X2.4 Stagger nails 1 3/4 in. apart—2 rows in each board.

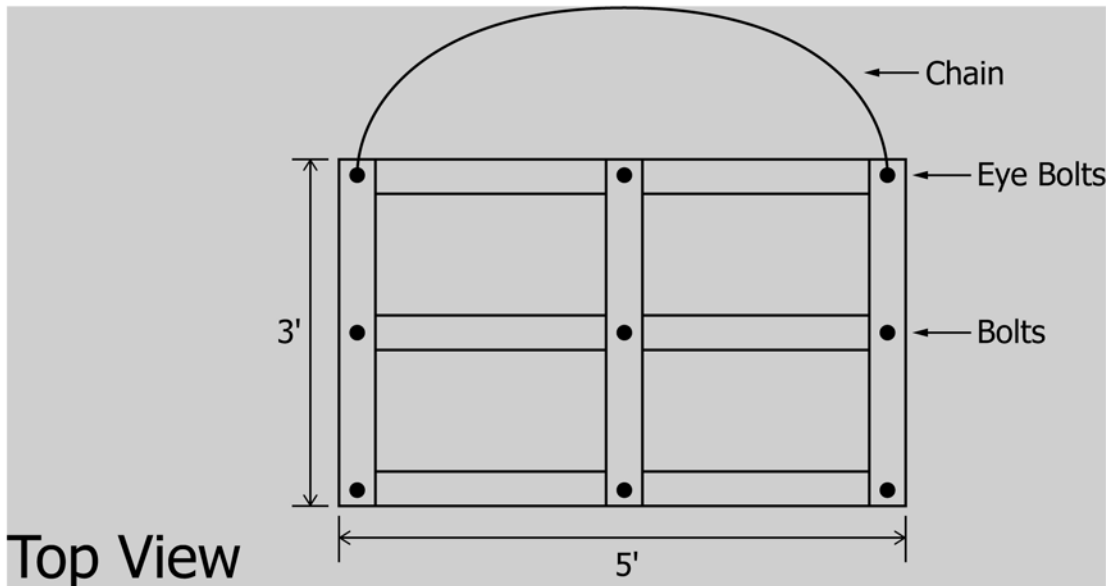

FIG. X2.1 Nail Drag Diagram

X3. RESOURCE MATERIALS

X3.1 For additional information related to sports fields, consult the following sources of information:

X3.1.1 Sports Turf Managers Association (STMA). STMA Headquarters, 805 New Hampshire, Ste. E, Lawrence, KS, 66044.

X3.1.2 Turfgrass Management Information Directory: Third Edition, Keith J. Karnok, Editor., Ann Arbor Press, Chelsea, MI, 2000. ISBN 1-57504-148-0.

REFERENCES

- (1) Waddington, D. V., "Soils, Soil Mixtures, and Soil Amendments," *Turfgrass Agronomy Monograph No. 32*, American Society of Agronomy, Madison, WI, 1992, pp. 331-383.
- (2) USDA. Soil Conservation Service, Soil Survey Staff, 1975, *Soil Taxonomy: A Basic System of Soil Classification for Making and Interpreting Soil Surveys*, USDA Handbook 436, U.S. Government Printing Office, Washington, DC.
- (3) USDA, Soil Conservation Service, Soil Survey Staff, 1993, *Soil Survey Manual*, USDA Handbook 18, U.S. Government Printing Office, Washington, DC.
- (4) USDA, Soil Conservation Service, Soil Survey Staff, 1997, *Keys to Soil Taxonomy*, 7th ed., Pocahontas Press, Blacksburg, VA.
- (5) Dixon, J. B., and Weed, S. B., 1989, *Minerals in Soil Environments*, 2nd ed., Soil Science Society of America, Madison, WI.
- (6) Soil Science Society of America, *Glossary of Soil Science Terms*, Soil Science Society of America, Madison, WI, 1997.
- (7) Brownell, W. E., *Structural Clay Products* (Applied mineralogy; v. 9), Springer-Verlag, Wien-New York, 1976.

ASTM International takes no position respecting the validity of any patent rights asserted in connection with any item mentioned in this standard. Users of this standard are expressly advised that determination of the validity of any such patent rights, and the risk of infringement of such rights, are entirely their own responsibility.

This standard is subject to revision at any time by the responsible technical committee and must be reviewed every five years and if not revised, either reapproved or withdrawn. Your comments are invited either for revision of this standard or for additional standards and should be addressed to ASTM International Headquarters. Your comments will receive careful consideration at a meeting of the responsible technical committee, which you may attend. If you feel that your comments have not received a fair hearing you should make your views known to the ASTM Committee on Standards, at the address shown below.

This standard is copyrighted by ASTM International, 100 Barr Harbor Drive, PO Box C700, West Conshohocken, PA 19428-2959, United States. Individual reprints (single or multiple copies) of this standard may be obtained by contacting ASTM at the above address or at 610-832-9585 (phone), 610-832-9555 (fax), or service@astm.org (e-mail); or through the ASTM website (www.astm.org). Permission rights to photocopy the standard may also be secured from the Copyright Clearance Center, 222 Rosewood Drive, Danvers, MA 01923, Tel: (978) 646-2600; <http://www.copyright.com/>