



# Standard Specification for Window Fall Prevention Devices With Emergency Escape (Egress) Release Mechanisms<sup>1</sup>

This standard is issued under the fixed designation F2090; the number immediately following the designation indicates the year of original adoption or, in the case of revision, the year of last revision. A number in parentheses indicates the year of last reapproval. A superscript epsilon ( $\epsilon$ ) indicates an editorial change since the last revision or reapproval.

## INTRODUCTION

This consumer safety specification addresses window fall prevention devices that protect against potential falls by children aged five years and under through open windows. Window fall prevention devices currently available include window opening control devices, window fall prevention screens, and some types of window guards. These devices use different strategies to prevent children from falling through open windows. Window opening control devices restrict the size of the open area of the window so that it is too small for a young child to fall through. They do this by allowing the window opening to be set at a predetermined position. Window fall prevention screens and fall prevention window guards provide a barrier to prevent a child from falling through an open window.

A special study<sup>2</sup> by the U.S. Consumer Product Safety Commission (CPSC) indicates that young children are at risk of death and serious injury from falls through open windows. Children aged five and younger account for a higher percentage of window fall fatalities and injuries.<sup>3</sup>

Window fall prevention devices usually differ in purpose and application from security/burglar bars. The general purpose of a window fall prevention device is to prevent a child age five or younger from falling through an open window. The general purpose of a security bar is to prevent unlawful entry through a window. Generally window fall prevention devices and security bars are two separate devices. However, a security bar could be used as a fall prevention device if it meets the requirements of this specification.

The CPSC has advised caregivers to open windows less than 4 in. when children are present as one means to prevent child falls through open windows. Window opening control devices provide a means that the window, when opened in an initial operation, will satisfy the CPSC recommendation to open less than 4 in.<sup>4</sup> The 4-in. dimension is drawn from related building codes and standards for openings in guardrail assemblies,<sup>5</sup> and is universally accepted as the appropriate dimension to prevent a child from passing through balcony or guard railing systems. An additional operation is required to open the window further. The additional operation must be performed without the use of keys, tools, or special knowledge. Security from forced entry is not within the scope of this standard and is not the intended function of any of the devices referred to herein.

The intent of this update to the standard is to improve the clarity of performance and labeling requirements and to reorganize the sections such that the general requirements, performance tests, safety information, labeling requirements, and installation instructions are separated by device type.

---

<sup>1</sup> This specification is under the jurisdiction of ASTM Committee F15 on Consumer Products and is the direct responsibility of Subcommittee F15.38 on Window Fall Prevention.

Current edition approved Dec. 15, 2013. Published December 2015. Originally approved in 2001. Last previous edition approved in 2010 as F2090 – 10. DOI: 10.1520/F2090-13.

<sup>2</sup> U.S. Consumer Product Safety Commission, *Special Window Falls Study*, conducted in 1991.

---

<sup>3</sup> U.S. Consumer Product Safety Commission, *Special Window Falls Study*, conducted in 1991 and “Window Safety: Data and Patterns Related to Entrapments and Accidental Falls from Windows,” prepared by Andersen Corporation.

Supporting data have been filed at ASTM International Headquarters and may be obtained by requesting Research Report RR:F15-1002.

<sup>4</sup> Consumer Product Safety Commission, “Preventing Window Falls,” Document #5124.

## 1. Scope

1.1 This specification establishes requirements for devices intended to address the risk of injury and death associated with accidental falls through open windows by children five years old and younger.

1.2 This specification is not intended to meet the unique requirements of Americans With Disabilities Act (ADA).

1.3 This specification applies to window fall prevention devices, including window opening control devices, window fall prevention screens, and fall prevention window guards, that are to be used on operable windows, including those that are designated for emergency escape (egress) and rescue (ingress).

NOTE 1—A separate safety specification, Safety Specification **F2006**, covers window fall prevention devices for non-emergency escape (egress) and rescue (ingress) windows in installations more than 75 ft<sup>6</sup> (23 m) above ground level in multiple family dwelling buildings since windows at these heights are beyond the reach of rescue ladders currently in use.

1.4 The values stated in inch-pound units are to be regarded as standard. The values given in parentheses are mathematical conversions to SI units that are provided for information only and are not considered standard.

1.5 *This standard does not purport to address all safety concerns, if any, associated with its use. It is the responsibility of the user of this standard to establish appropriate safety and health practices and to determine the applicability of regulatory limitations prior to use.*

## 2. Referenced Documents

### 2.1 ASTM Standards:<sup>7</sup>

- F977** Consumer Safety Specification for Infant Walkers
- F1487** Consumer Safety Performance Specification for Playground Equipment for Public Use
- F2006** Safety Specification for Window Fall Prevention Devices for Non-Emergency Escape (Egress) and Rescue (Ingress) Windows

### 2.2 Code of Federal Regulations:<sup>8</sup>

- 16 CFR 1500.53** Test Methods for Simulating Use and Abuse of Toys and Other Articles Intended for Use by Children Over 36 But Not Over 96 Months of Age, (f)(3) Testing Procedure
- 16 CFR 1508.6(b)** Requirements for Full-Size Baby Cribs
- CPSC 16 CFR Chapter 11 (1-1-87 Edition) Part 1201** Safety Standard for Architectural Glazing Materials

### 2.3 ANSI Standards:<sup>9</sup>

- ANSI Z535.4** Product Safety Signs and Labels

- ANSI Z535.6** Product Safety Instructions in Product Manuals, Instructions and Other Collateral Materials
- ANSI Z97.1** Safety Glazing Materials Used in Buildings — Safety Performance Specifications and Methods of Test (Tempered Glass Impact Test)
- ANSI/BHMA A156.9** American National Standard for Cabinet Hardware
- ANSI/SMA 1201** Specification for Insect Screens for Windows, Sliding Doors and Swinging Doors
- 2.4 *AAMA Standards*:<sup>10</sup>
  - AAMA/WDMA/CSA 101/IS.2/A440** North American Fenestration Standard/Specification for Windows, Doors, and Skylights (NAFS)
  - AAMA 902** Voluntary Specification for Sash Balances

## 3. Terminology

### 3.1 Definitions of Terms Specific to This Standard:

3.1.1 *aftermarket*, *adj*—referring to a product or device that is manufactured separately from a window but is intended to be used in conjunction with a window. For purposes of this standard, such a device is intended to be attached to or near a window or its frame in order to prevent a young child from passing or falling through the window when the window is opened.

3.1.2 *emergency escape (egress) and rescue (ingress) window*, *n*—a window intended for emergency escape (egress) and rescue (ingress) during an emergency situation such as fire, gas leak, etc., as defined by the prevailing applicable building and fire codes.

3.1.3 *fall prevention window guard*, *n*—device designed to fit into or onto a window to prevent a child from passing or falling through an open window. Typically mounted on the interior frame of the window and includes side frames fastened to the sides of a window frame and a plurality of spaced-apart, transverse, tubular, width-adjustable crosspiece elements to form a grid pattern between the side supports to prevent passage of a child. See **Appendix X3** for examples.

3.1.4 *release mechanism for emergency escape (egress) and rescue (ingress) window fall prevention device*, *n*—means of opening a window fall prevention screen or fall prevention window guard or releasing a window opening control device to provide a clear opening space for the purpose of emergency escape or rescue.

3.1.5 *window*, *n*—an opening constructed in a wall or a roof to admit light or air, or both, to any enclosure.

3.1.6 *window fall*, *n*—a fall through an open window.

3.1.7 *window fall prevention device*, *n*—any device intended to prevent a young child from passing or falling through an open window. Such a device may be an integral part of a window, or may be attached to the window, its frame, or the area around the window after the window has been installed.

3.1.8 *window fall prevention screen*, *n*—screen device designed to fit into or onto a window to prevent a child from

<sup>5</sup> See NFPA 101, 2012 Edition, Section 7.2.2.4.5.3. Also see Section R312.2, guard opening limitations in the 2006 International Residential Code (IRC).

<sup>6</sup> 2006 *International Building Code*, Section 403.1, Special Provisions for Groups B and R1, January 2000.

<sup>7</sup> For referenced ASTM standards, visit the ASTM website, [www.astm.org](http://www.astm.org), or contact ASTM Customer Service at [service@astm.org](mailto:service@astm.org). For *Annual Book of ASTM Standards* volume information, refer to the standard's Document Summary page on the ASTM website.

<sup>8</sup> *Code of Federal Regulations*, available from U.S. Government Printing Office, Washington, DC 20402.

<sup>9</sup> Available from American National Standards Institute (ANSI), 25 W. 43rd St., 4th Floor, New York, NY 10036, <http://www.ansi.org>.

<sup>10</sup> Available from American Architectural Manufacturers Association, 1827 Walden Office Square, Suite 550, Schaumburg, IL 60173, <http://www.aamanet.org/index.asp>.

passing or falling through an open window. Typically mounted on the exterior surface/frame of a sliding style window and on the interior of a cranking style window and includes screening mesh or material and attachment mechanism(s) of sufficient strength to meet the performance requirements of this standard while preventing passage of a child. See [Appendix X4](#) for examples.

3.1.9 *window opening control device, n*—device that controls a window sash opening to be opened with normal operation of the sash such as to prohibit the free passage of a 4.0-in. (102-mm) diameter rigid sphere<sup>11</sup> at the lowest opening portion of the window opening, with a release mechanism that shall allow the sash to be opened to a larger opening area such as that required for emergency escape and rescue, and that automatically resets when the window sash is fully closed. See [Appendix X5](#) for examples.

3.1.9.1 *controlled open position, n*—maximum open position of a window sash, when the window opening control device(s) is engaged, that prohibits the free passage of a 4-in. (102-mm) diameter rigid sphere.

## WINDOW FALL PREVENTION SCREENS AND FALL PREVENTION WINDOW GUARD DEVICES

### 4. General Requirements

4.1 Window fall prevention screens or fall prevention window guard devices shall be constructed so as to prohibit the free passage of a 4.0-in. (102-mm) diameter rigid sphere<sup>12</sup> anywhere in the window opening (as required by applicable codes for that jurisdiction), during or after testing as specified in [5.1 – 5.4](#), when the window fall prevention screen or fall prevention window guard device is installed in accordance with the manufacturer’s instructions.

4.2 The distance between window fall prevention screen or fall prevention window guard device structural members or components after all testing is conducted shall not exceed 4.0 in. (102 mm) when a 60-lbf<sup>13</sup> (267-N) direct force is applied in accordance with the test method in [5.2](#).

4.3 Releasable window fall prevention screen or fall prevention window guard devices shall be free of sharp projections and edges.

4.4 Releasable window fall prevention screens or fall prevention window guard devices shall not interfere with the operation, function or performance of the window to applicable standards and shall not violate light, ventilation, and emergency escape and rescue requirements of the applicable building code.

<sup>11</sup> CPSC Publication 362, “Safety Barrier Guidelines for Home Pools” and New Jersey Community Affairs Division of Codes and Standards, Cite 27 N.M.R. 3150, Subchapter 27 Child-Protection Window Guards — 5:10 — 27.4 — Specifications for Window Guards.

<sup>12</sup> CPSC Publication 362, “Safety Barrier Guidelines for Home Pools” and New Jersey Community Affairs Division of Codes and Standards, Cite 27 N.M.R. 3150, Subchapter 27 Child-Protection Window Guards — 5:10 — 27.4 — Specifications for Window Guards.

<sup>13</sup> “Anthropometry of Infants, Children, and Youths to Age 18 for Product Safety Design,” Highway Safety Research Institute, University of Michigan, May 31, 1977.

4.5 Window fall prevention screens or fall prevention window guard devices shall be designed with release mechanisms to allow for emergency escape (egress) without the need for special tools or special knowledge.

4.5.1 Operation of emergency escape (egress) mechanisms shall be accomplished with a minimum amount of effort from the inside of the building, whether the window fall prevention screen and fall prevention window guard device is mounted inside or outside the building.

4.5.2 Release of the emergency escape (egress) mechanism shall require no more than 15 lbf (66 N) of force.<sup>14</sup>

4.5.3 To protect against inadvertent operation by a young child, the emergency escape (egress) release mechanism(s) shall require two distinct actions to operate.<sup>15</sup> Opening the window fall prevention screen or fall prevention window guard shall not count as one of these actions.

4.5.4 The emergency escape (egress) release mechanism shall operate properly in all types of weather.

4.5.5 Emergency escape (egress) releases shall have their operating mechanisms clearly identified for proper use in an emergency.

4.5.6 Neither the window fall prevention screens or fall prevention window guard devices nor the emergency escape (egress) release mechanism shall reduce the exitable area of the window unit below what is required by applicable codes.

4.5.7 The location of the release mechanism to be used to open the window fall prevention screens or fall prevention window guard devices shall be visible.

4.6 Window fall prevention screens or fall prevention window guard devices, if hinged, shall be hinged on one side (not top or bottom) to provide easy escape (egress) and if interior mounted shall not operate outward.

4.7 Once released, window fall prevention screen or fall prevention window guard devices shall not re-engage until manually closed.

4.8 Releasable window fall prevention screen or fall prevention window guard devices shall be designed in a manner that does not accommodate the use of locking devices which require special knowledge or tools to operate, such as combination locks or keyed locks, whereby the device could be locked in a closed position to some part of the building structure or to some non-moveable portion of the device itself and thereby be rendered not readily operable in the event of an emergency.

4.9 Each releasable window fall prevention screen or fall prevention window guard device shall be sold with installation instructions and safety information included in the packaging for each device.

4.10 Installation instructions shall include the statement that a copy of the safety information shall be provided to the owner

<sup>14</sup> 16 CFR 1500.53, Test Methods for Simulating Use and Abuse of Toys and Other Articles Intended for Use by Children Over 36 But Not Over 96 Months of Age, (f)(3) Testing Procedure.

<sup>15</sup> 16 CFR 1508.6(b), Requirements for Full-Size Baby Cribs.

of the building in which the device is installed and to the occupant in the dwelling where the device is installed (or is to be installed).

4.11 Installation instructions and safety information shall be conspicuous.

4.12 Installation instructions and safety information shall specify maximum window opening width and height for which the window fall prevention device is intended.

4.13 Additional requirements for window fall prevention screen assemblies used as window fall prevention devices.

4.13.1 Window fall prevention screen assemblies designed for exterior installation shall meet the weathering and durability requirements of ANSI/SMA 1201: “Specification for Insect Screens for Windows, Sliding Doors and Swinging Doors.”

4.13.2 Attachment of window fall prevention screen assemblies to window units, framing, or surrounding materials shall not interfere with the operation, function, or performance of the window to applicable standards, and shall not violate light, ventilation, and emergency escape and rescue requirements of the applicable building code.

4.13.3 Window fall prevention screen assemblies used as window fall prevention devices shall comply with applicable standards contained in ANSI/SMA 1201: “Specification for Insect Screens for Windows, Sliding Doors and Swinging Doors.”

4.13.4 Where window fall prevention screens are considered, the person specifying the window fall prevention screen(s) shall refer to this specification or Safety Specification **F2006**.

NOTE 2—Insect screens are intended to provide reasonable insect control and are not intended nor designed for the purpose of providing security or to provide for the retention of objects or persons.

## 5. Performance Tests

### 5.1 *Preparing Specimen for Testing:*

5.1.1 Window fall prevention guards shall be extended to the maximum width and height as specified by the manufacturer. Extended fall prevention window guards and window fall prevention screens shall be mounted in a test frame or holder assembly using installation techniques that are representative of the same mounting devices and techniques as recommended in the manufacturer’s installation instructions. All testing shall be done with the fall prevention window guard or window fall prevention screen device placed so that its inside (exposed) surfaces are subjected to the applied forces under **5.2** and **5.3.3**.

5.1.2 The test supports shall be located in such a manner that they are contacting only the test frame and not providing any support directly to the installed window fall prevention device.

5.1.3 Use the same window fall prevention device specimen for all performance tests (**5.2 – 5.4**). Test following the order indicated by the performance test number sequencing.

### 5.2 *Static Load (Hang) Test:*

5.2.1 A load distribution device<sup>16</sup> capable of exerting a 60 lb (267 N) force shall be used.

5.2.2 This test shall be performed for each different type of component in the window fall prevention device (vertical bars, horizontal bars, webbing, or other graspable components, etc.).

5.2.3 With the window fall prevention device installed as specified in **5.1.1**, suspend the load distribution device from each of the individual component part members of the window fall prevention device (for example, hang the weight from a horizontal bar component or from a member or opening of webbing, or other graspable component) in a manner that simulates the anticipated load representative of a child hanging from any individual part of the window fall prevention device.

5.2.4 Apply a vertical force of 60 lb on the component at any representative point within or on the device. Reasoning statement: To simulate the weight of a five year old child hanging from any component/part of the device.

5.2.5 Once the test weight is removed, the tested specimen is inspected to determine that the window fall prevention device shall prohibit the free passage of a 4.0 in. (102 mm) diameter rigid sphere through or around it anywhere in the window opening (as required by applicable codes for that jurisdiction).

5.2.6 The latching or locking device of release mechanism shall remain engaged and operative after testing.

### 5.3 *Pendulum Test:*<sup>17</sup>

5.3.1 *Rationale*—This test is based on subjecting the window fall prevention screen or fall prevention window guard device to 100 ft-lb (136 J) of energy. This is the energy that would be generated by a 50-lb (22.7-kg) child (95th percentile 5-year-old) falling directly onto the window fall prevention device from a height of 2 ft or running directly into the window fall prevention device at a speed of 11.4 ft/s (3.48 m/s) (approximately 50th percentile 6-year-old sprint speed; 6 years is the youngest age for which data are available).<sup>18</sup>

NOTE 3—100 ft-lb is a reasonably stringent criterion. If, while bouncing on a bed for instance, the child fell against the window fall prevention device, it is not likely that all of the energy from such a fall would be directed straight into the window fall prevention device, as it is in the testing situation. In addition, the window fall prevention device is not intended to protect against an intentional all-out effort on the part of the child to run through the window fall prevention device.

5.3.2 *Test Objective*—The test determines the fall prevention device’s resistance to allowing an opening to develop that would permit a child to pass through after being impacted. The fall prevention device must not have an opening larger than the maximum space as prescribed by **4.1**. If such a space is found after the test, this will constitute failure of the device.

### 5.3.3 *Test Procedure:*

5.3.3.1 The fall prevention device is mounted into the test fixture utilizing the manufacturer’s written installation instructions.

<sup>17</sup> Test procedure based upon data found in CPSC 16 CFR Chapter 11 (1-1-87 Edition) Part 1201 and ANSI Z97.1-1984.

<sup>18</sup> Maximum Running Speed 167, Childata The Handbook of Child Measurements and Capabilities – Data for Design Safety, Department of Trade and Industry, UK, June 1995, Beverley Norris and John R. Wilson, Eds., Institute for Occupational Ergonomics, Department of Manufacturing Engineering and Operations Management, University of Nottingham, University Park, Nottingham NG7 2RD, UK.

<sup>16</sup> Such as Fig. 36 of Consumer Safety Performance Specification **F1487-95**.



5.3.3.2 The impactor (100 lb) (45.3 kg), such as in Figures 2 and 3 from ANSI Z97.1 (see [Appendix X1](#)), is prepared and mounted to the test fixture cable so that when at rest it is no farther than 2 in. (50 mm) away from the horizontal and vertical center of the window fall prevention device.

5.3.3.3 The impactor is pulled away from the specimen until the bottom of the impactor rises to the vertical distance of 12 in. (300 mm) above the at rest position.

5.3.3.4 When all motion has stopped, the impactor is released and allowed to impact once into the test specimen.

5.3.3.5 Once the impact is completed and the test weight is removed, the tested specimen shall prohibit the free passage of a 4.0-in. (102-mm) diameter rigid sphere through or around it anywhere in the window opening (as required by applicable codes for that jurisdiction).

5.3.3.6 The latching or locking device of the release mechanism shall remain engaged and operative after testing.

#### 5.4 *Release Mechanism Test:*<sup>19</sup>

5.4.1 Apply a force of no greater than 15 lbf (66 N) in the direction normally associated with opening (releasing) the release mechanism of the window fall prevention device in accordance with manufacturer’s instructions.

5.4.1.1 Neither of the two distinct actions necessary to activate the release mechanism shall require a force greater than 15 lbf (66 N).

5.4.2 The window fall prevention device shall open promptly after the release mechanism has been activated.

5.4.3 Re-secure window fall prevention device into a closed position.

5.4.4 Perform this procedure for a total of five times with zero failures within a 2-min<sup>20</sup> period. The release mechanism shall not fail to operate.

## 6. Safety Information

6.1 Safety information shall be distinct from the Installation Instructions. Safety information shall be headed “IMPORTANT SAFETY INFORMATION” and shall contain a note of attention to the installer to leave the safety information behind for the occupant.

6.2 Safety information shall include at least the information, signal word panels, and graphics contained in [6.4](#), [6.5](#), and [6.6](#). (Sample safety information is included in [Appendix X2](#).)

6.3 Safety information shall specify that window fall prevention devices, including window fall prevention screens, or fall prevention window guards (Note to manufacturers: Use whatever term applies to your device) shall be installed in such a manner that, after the device is installed and engaged, no space shall exist anywhere in the window opening (as required by applicable codes for that jurisdiction) that would permit the passage of a rigid sphere measuring 4.0 in. (102 mm) in diameter.

<sup>19</sup> Based upon data found in Consumer Safety Specification [F977–96](#) and Underwriter’s Laboratories Research Report for Window Bars “Releasing Systems for Window Bars in Residential Occupancies,” Subject 2326, Dec. 17, 1999.

<sup>20</sup> Based upon data found in Consumer Safety Specification [F977–96](#), Subsection 5.1.3.

6.3.1 The safety information in [6.4](#), [6.5](#) and [6.6](#) shall be headed by a signal word panel (see below) and shall contain the word “WARNING” in upper case letters, preceded by a safety alert symbol consisting of an exclamation mark inside a solid equilateral triangle background with the point of the triangle oriented upward. The word “WARNING” and the safety alert symbol shall be centered on one line and shall be in letters at least 5/16 in. (7.9 mm) high.

### △WARNING

6.4 The safety information shall include the statement of the hazard, “No Window Rescue Above 75 ft (6<sup>th</sup> Floor),” and shall contain the following information:

### △WARNING

#### No Window Rescue Above 75 ft (6<sup>th</sup> Floor)

- Fire rescue ladder may not reach beyond 75 ft (6<sup>th</sup> floor).
- Do not rely on being rescued from windows above 75 ft (6<sup>th</sup> floor). Follow building fire escape plan.

6.5 The safety information shall include the statement of the hazard, “Blocks Escape in Fire and Emergency Unless Released,” and shall contain the following information:

### △WARNING

#### Blocks Escape in Fire and Emergency Unless Released

- Need to properly operate release mechanism to open window fall prevention device, window fall prevention screen, or fall prevention window guard (Note to manufacturer: Use whatever term applies to your device) by:
  - Note to manufacturer: Give instruction on how to correctly operate the release mechanism on your particular window fall prevention device.
- Never apply padlocks or devices that require a key or tool to unlock them to the release mechanism and/or window fall prevention device, window fall prevention screens, or fall prevention window guards (Note to manufacturer: Use whatever term applies to your device).

6.6 The safety information shall include the statement of the hazard; “Possible Fall Hazard” and shall contain the following information:

### △WARNING

#### Possible Fall Hazard

- If window fall prevention device, window fall prevention screens, or fall prevention window guards (Note to manufacturer: Use whatever term applies to your device) is too small for the window opening, accidental window falls can result.
- Follow manufacturer’s assembly and installation instructions carefully. Failure to do so may result in accidental window falls.
- This window fall prevention device, window fall prevention screens, or fall prevention window guards (Note to manufacturer: Use whatever term applies to your device) is designed to protect against accidental window falls by children five years and younger.

- This window fall prevention device, window fall prevention screens, or fall prevention window guards (Note to manufacturer: Use whatever term applies to your device) is not a substitute for attentive supervision of all young children.
- Keep window fall prevention device, window fall prevention screens, or fall prevention window guards (Note to manufacturer: Use whatever term applies to your device) closed securely unless needed for use in an emergency.

6.7 Safety information shall describe how to re-engage the window fall prevention device, window fall prevention screens, or fall prevention window guards (Note to manufacturer: Use whatever term applies to your device) after activation of device to check for operability.

6.8 Safety information shall include directions on how to operate the release mechanism and provide an explanation for the need to activate the release mechanism.

6.9 Safety information shall include recommendations that release mechanism and releasable window fall prevention device, window fall prevention screens, or fall prevention window guards (Note to manufacturer: Use whatever term applies to your device) be maintained and tested on a monthly basis (once a month) and after testing be closed securely.

6.10 Safety information shall include recommendations that all household members six years old and older should know how to operate the release mechanism in case of an emergency.

## 7. Labeling Requirements

7.1 The aftermarket window fall prevention device, window fall prevention screens, or fall prevention window guards shall be marked or identified in a manner as to provide traceability to the manufacturer.

7.2 The packaging for the window fall prevention device, window fall prevention screens, or fall prevention window guards shall identify the name of the manufacturer, retailer or distributor, any appropriate applications and restrictions such as maximum window opening width and height and the statement “this device complies with ASTM F2090-13” on or in the packaging.

7.3 Explain the function of the aftermarket window fall prevention device, window fall prevention screens, or fall prevention window guards and how to operate the release mechanism (indicated by “Do XXXXX to Escape”) by including in or on the packaging or on a tag, label or marking on the device, the following information:

Window Fall Prevention Device  
(Note to manufacturer:  
Use whatever term applies to your device)  
In Emergency  
Do XXXXX to Escape

## 8. Installation Instructions

8.1 Installation instructions for window fall prevention screens and fall prevention window guards shall specify that window fall prevention devices shall be installed in such a

manner that no space shall exist in the lowest part of the clear opening area of the window (as required by applicable codes for that jurisdiction) with the window fall prevention device installed that would permit the free passage of a rigid sphere measuring 4.0 in. (102 mm) in diameter. Installation instructions shall state that failure to follow these instructions may result in the window fall prevention device’s being ineffective in preventing falls through an open window.

8.2 Installation instructions shall specify application to specific window type. The installation instructions shall include all details of recommended attachment materials and techniques of installation that will provide for support equal to or greater than the attachment methods and materials used to meet the test requirements as described in 5.1 – 5.4. Installation instructions shall include the statements specified in 8.2.2 and 8.2.3.

8.2.1 Installation instructions shall specify that building and fire codes should be consulted before installing window fall prevention devices. Contact local building code department or fire department for specific codes.

8.2.1.1 Window fall prevention device shall be installed such that the release mechanism(s) is in conformance with local building and fire code requirements.

8.2.2 Where a warning<sup>21</sup> is required by this specification within the installation instructions, a signal word panel (see below) that contains the word “WARNING” in upper case letters, preceded by a safety alert symbol consisting of an exclamation mark inside a solid equilateral triangle background with the point of the triangle oriented upward shall head the information. The word “WARNING” and the safety alert symbol shall be centered on one line and shall be in letters at least 5/16 in. (7.9 mm) high.

### △WARNING

8.2.3 Within the installation instructions a warning message shall include the statement of the hazard: “Possible Fall Hazard” and shall contain the following information:

### △WARNING Possible Fall Hazard

- Young children may fall out of the window if the window fall prevention device is not installed correctly.
  - Install the device so that a rigid 4.0-in. diameter sphere does not pass through any space in the window opening after the window fall prevention device is in place.
- Young children may fall out the window if all installation instructions are not followed:
  - Use recommended materials and techniques.
  - Make sure the fall prevention device is securely attached to the window frame.
  - Make sure that the window frame is in good condition.

8.2.4 Installation instructions shall include directions to check release mechanism for operability when installation is completed and then close securely.

<sup>21</sup> WARNING format to be written in accordance with ANSI Z535.4, “Product Safety Signs and Labels,” and ANSI Z535.6, “Product Safety Instructions in Product Manuals, Instructions and Other Collateral Materials,” requirements unless otherwise approved by applicable building codes or fire codes, or both.

8.2.5 Installation instructions shall describe how to re-engage the window fall prevention device after activation of release mechanism to check for operability.

## WINDOW OPENING CONTROL DEVICES

### 9. General Requirements

9.1 Window opening control devices shall meet the performance requirements of Section 10.

9.2 Window opening control devices, when properly installed and engaged, shall prohibit the free passage of a 4.0-in. (102-mm) diameter rigid sphere<sup>22</sup> through the window opening before and immediately after testing in accordance with 10.1 – 10.5.

9.3 Window opening control devices shall be designed with release mechanisms to allow for emergency escape (egress) without the need for keys, tools or special knowledge. Window latching hardware meeting the requirements of this standard shall be permitted to serve as the release mechanism.

9.3.1 Window opening control devices shall be designed and installed so that they will function properly during normal operation of the window to limit the opening area, while maintaining structural integrity and durability.

9.3.2 To protect against inadvertent opening of the window sash beyond the controlled open position by a young child, the emergency escape (egress) release mechanism(s) of the window opening control device(s) shall consist of either two independent single action mechanisms or one dual action mechanism. Operation of the sash shall be able to be performed independently of operation of the release mechanism.

9.3.2.1 *Single Action Mechanisms*—Operation of the two independent single action emergency escape (egress) release mechanisms shall be able to be performed consecutively.

9.3.2.2 *Dual Action Mechanism*—The dual action emergency escape (egress) release mechanism shall require two separate, distinct, and consecutive actions to release the mechanism. Maintaining the first action while performing the second action, such as pushing and then turning, shall be permitted for a dual action device, as long as the two actions are separate, distinct and consecutive.

9.3.3 Emergency escape (egress) releases shall have their operating mechanisms readily visible.

9.3.4 The window opening control device and emergency escape (egress) release mechanism shall not reduce the open area of the window unit beyond applicable code requirements.

9.4 Once released, when the window sash is returned to a fully closed position, the window opening control device(s) release mechanism(s) shall automatically reset. Resetting shall occur at any position between the controlled open position and the fully closed position.

9.5 Window opening control devices shall not interfere with the operation, function or performance of the window to applicable standards referenced herein.

<sup>22</sup> CPSC Publication 362, “Safety Barrier Guidelines for Home Pools” and New Jersey Community Affairs Division of Codes and Standards, Cite 27 N.M.R. 3150, Subchapter 27 Child-Protection Window Guards — 5:10 — 27.4 — Specifications for Window Guards.

### 10. Performance Tests

10.1 Release of the emergency escape (egress) mechanism of the window opening control device shall require no more than 15 lbf (66 N) of force.<sup>23</sup>

10.2 All window opening control devices shall be subjected to load testing in a fixture that permits loading in the opening direction of the sash. The load test<sup>24</sup> (force) shall be 75 lbf (333 N). The application of the 75 lbf (333 N) pre-cycle testing load test shall be repeated five times.<sup>25</sup> The test load shall be applied for a minimum of 10 s and then removed and the unit inspected. There must be no chipping (other than cosmetic damage), disassembly or breakage of the part, or attachment mechanism(s) or fasteners.

NOTE 4—The purpose of this pre-cycling test load test is to establish a baseline.

NOTE 5—Testing of the two independent single action window opening control devices shall be performed on the two devices simultaneously because two such devices are required for each window sash.

10.3 The window opening control devices shall be subjected to cycle testing for durability. The window opening control devices shall be tested to a minimum of 4000 cycles.<sup>26</sup> A cycle shall comprise the full operation and release of each device. There shall be no load applied during the cycle testing.

10.4 After completion of the cycle testing specified in 10.3, the static load test of 10.2 shall be repeated 100 times.<sup>27</sup>

10.5 After testing in accordance with 10.2, 10.3, and 10.4, the window opening control device(s) shall remain operational and shall comply with the requirements in 10.1, 9.4, and the opening dimension requirements in 9.2.

### 11. Safety Information

11.1 Safety information shall be distinct from the Installation Instructions. Safety information shall be headed “IMPORTANT SAFETY INFORMATION” and shall contain a note of attention to the installer to leave the safety information behind for the occupant.

11.2 Safety information shall specify that when the window opening control device is properly installed and engaged, that no space shall exist at the lowest opening portion of the window opening that would permit the passage of a rigid sphere measuring 4.0 in. (102 mm) in diameter. Installation instructions shall state that failure to follow these instructions may result in the window opening control device’s being ineffective in controlling the window opening.

11.3 The safety information in 11.4, 11.5, and 11.6 shall be headed by a signal word panel (see below) and shall contain the

<sup>23</sup> 16 CFR 1500.53, Test Methods for Simulating Use and Abuse of Toys and Other Articles Intended for Use by Children Over 36 But Not Over 96 Months of Age, (f)(3) Testing Procedure.

<sup>24</sup> ANSI/BHMA A156.9, American National Standard for Cabinet Hardware.

<sup>25</sup> AAMA/WDMA/CSA 101/IS.2/A440, North American Fenestration Standard/Specification for Windows, Doors, and Skylights.

<sup>26</sup> AAMA 902, Voluntary Standard for Sash Balances, Section 7.6.

<sup>27</sup> Rationale: One hundred cycles of load testing is an estimate intended to simulate the number of times, in the useful life of a window opening control device(s), an adult may try to open a window sash without first releasing the window opening control device(s).

word “WARNING” in upper case letters, preceded by a safety alert symbol consisting of an exclamation mark inside a solid equilateral triangle background with the point of the triangle oriented upward. The word “WARNING” and the safety alert symbol shall be centered on one line and shall be in letters at least  $\frac{5}{16}$  in (7.9 mm) high.

**△WARNING**

11.4 The safety information shall include the statement of the hazard, “No Window Rescue Above 75 ft (6<sup>th</sup> Floor),” and shall contain the following information:

**△WARNING**

**No Window Rescue Above 75 ft (6<sup>th</sup> Floor)**

- Fire rescue ladder may not reach beyond 75 ft (6<sup>th</sup> Floor).
- Do not rely on being rescued from windows above 75 ft (6<sup>th</sup> Floor). Follow building fire escape plan.

11.5 The safety information shall include the statement of the hazard, “Blocks Escape in Fire and Emergency Unless Released,” and shall contain the following information:

**△WARNING**

**Blocks Escape in Fire and Emergency Unless Released**

- Need to properly operate release mechanism to open window opening control device by:
- Note to manufacturer: Give instruction on how to correctly operate the release mechanism on your particular window opening control device.
- Never apply padlocks or devices that require a key or tool to unlock them to the release mechanism of the window opening control device(s).

11.6 The safety information shall include the statement of the hazard; “Possible Fall Hazard” and shall contain the following information:

**△WARNING**

**Possible Fall Hazard**

- This window opening control device(s) is designed to protect against accidental operation of windows by children five years and younger.
- This window opening control device(s) is not a substitute for attentive supervision of all young children.
- Keep window opening control device(s) properly engaged unless needed for use in an emergency.

11.7 Safety information shall describe how to re-engage the window opening control device(s) after activation of device to check for operability.

11.8 Safety information shall include directions on how to operate the release mechanism and provide an explanation for the need to activate the release mechanism.

11.9 Safety information shall include recommendations that release mechanism and releasable window opening control device(s) be maintained and tested on a monthly basis (once a month) and after testing be closed securely.

11.10 Safety information shall include recommendations that all household members six years old and older should know how to operate the release mechanism in case of an emergency.

11.11 Within the installation instructions a warning message shall include the statement of the hazard: “Possible Fall Hazard” and shall contain the following information:

**△WARNING**

**Possible Fall Hazard**

- Young children may fall out of the window if the opening control device is not installed correctly.
- Install the device so that a rigid 4.0-in. diameter sphere does not pass through any space in the window opening after the window opening control device is in place.
- Young children may fall out the window if all installation instructions are not followed:
- Use recommended materials and techniques.
- Make sure that the window opening control device is securely installed in accordance with manufacturer’s instructions.
- Make sure that the window frame is in good condition.

**12. Labeling Requirements**

12.1 Window opening control device(s) shall be marked or identified in a manner as to provide traceability to the manufacturer.

12.2 The packaging for the window opening control device(s) shall identify the name of the manufacturer, retailer, or distributor, any appropriate applications, and the statement “this device complies with ASTM F2090-13” on or in the packaging.

12.3 Explain the function of the window opening control device(s) and how to operate the release mechanism (indicated by “Do XXXXX to Escape”) by including in or on the packaging or on a tag, label, or marking on the device, or in the safety information the following information:

Window Opening Control Device  
In Emergency  
Do XXXXX to Escape

**13. Installation Instructions**

13.1 Each aftermarket window opening control device shall be sold with installation and operating instructions and safety information included in the packaging. Installation instructions shall include the statement that a copy of the safety information shall be provided to the owner of the building in which the opening control device is installed and to the occupant in the dwelling where the opening control device is installed (or is to be installed).

13.2 Installation instructions and safety information shall specify any applicable design limitations, including maximum window width and height for which the window opening control device is intended.

13.3 Installation instructions shall specify application to specific window type. The installation instructions shall include all details of recommended attachment materials and



techniques of installation that will provide for support equal to or greater than the attachment methods and materials used to meet the test requirements as described in 10.1 – 10.5.

13.4 Follow manufacturer’s assembly and installation instructions carefully. Failure to do so may result in accidental window falls.

13.5 Installation Instructions shall specify that building and fire codes shall be consulted before installing window opening control devices. Contact local building code department or fire department for specific applicable codes.

13.6 Window opening control devices shall be installed such that the release mechanism(s) is in conformance with local building and fire code requirements.

13.7 Installation instructions shall include directions to check release mechanism for operability when installation is completed and then close securely.

13.8 Installation instructions shall describe how to re-engage the window opening control device after activation of release mechanism to check for operability.

13.9 Within the installation instructions a warning message shall include the statement of the hazard: “Possible Fall Hazard” and shall contain the following information:

**△WARNING**

**Possible Fall Hazard**

- Young children may fall out of the window if the opening

control device is not installed correctly.

- Install the device so that a rigid 4.0-in. diameter sphere does not pass through any space in the window opening after the window opening control device is in place.
- Young children may fall out the window if all installation instructions are not followed:
- Use recommended materials and techniques.
- Make sure that the window opening control device is securely installed in accordance with manufacturer’s instructions.
- Make sure that the window frame is in good condition.

13.10 Warnings<sup>28</sup> provided within the installation instructions shall have a signal word panel (see 11.11) that contains the word “WARNING” in upper case letters, preceded by a safety alert symbol consisting of an exclamation mark inside a solid equilateral triangle background with the point of the triangle oriented upward shall head the information. The word “WARNING” and the safety alert symbol shall be centered on one line and shall be in letters at least  $\frac{5}{16}$  in. (7.9 mm) high.

## 14. Keywords

14.1 fall prevention window guards; falls; release mechanism; secondary means of escape; window fall prevention devices; window fall prevention screens; window opening control device; windows

---

<sup>28</sup> WARNING format to be written in accordance with ANSI Z535.4, “Product Safety Signs and Labels,” and ANSI Z535.6, “Product Safety Instructions in Product Manuals, Instructions and Other Collateral Materials,” requirements unless otherwise approved by applicable building codes or fire codes, or both.

APPENDICES

(Nonmandatory Information)

X1. FIGURES 2 AND 3 FROM ANSI Z97.1

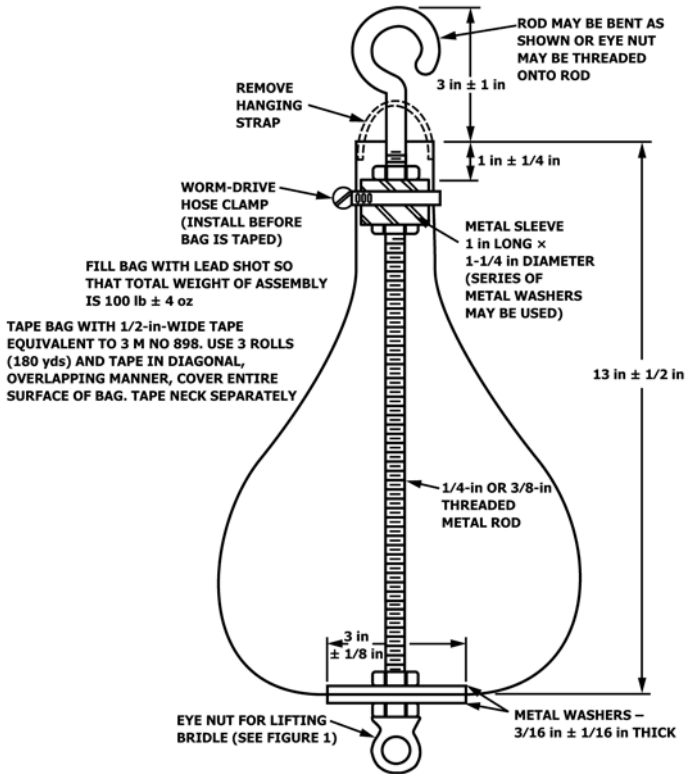

Figure 2 Impactor

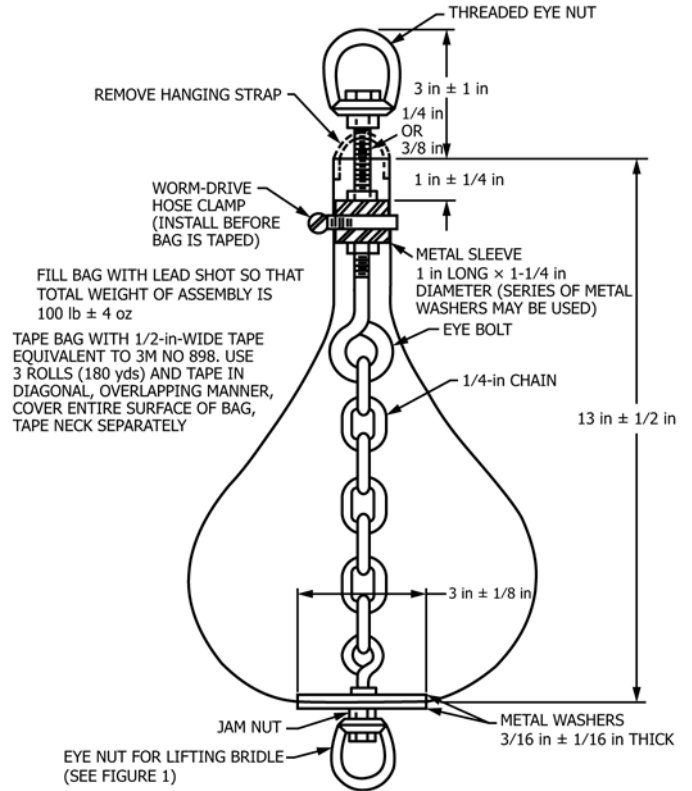



Figure 3 Impactor

X2. SAMPLE SAFETY INFORMATION PANELS

**⚠ WARNING**

**Fall Hazard if Window Fall Prevention Device is Not Properly Installed**



**Installed too High**

- If window fall prevention device is too small, falls can result.
- Follow manufacturer's assembly and installation instructions carefully. Failure to do so may result in falls.
- This window fall prevention device is designed to protect against accidental window falls by children 5 years old and younger.
- This window fall prevention device is not a substitute for supervision of young children.



**Installed too Low**

**⚠ WARNING**

**No Window Rescue Above 75 feet (6th Floor)**





- Fire rescue ladder may not reach beyond 75 feet (6th floor).
- Do not rely on being rescued from windows above 75 feet (6th floor). Follow building fire escape plan.

**⚠ WARNING**

**Blocks Escape in Fire and Emergency Unless Released**



- Need to properly operate release mechanism to open window fall prevention device by:

**Note to manufacturer:**  
-Give detailed instruction on release mechanism operation-

- Never apply padlocks or devices that require a key or tool to unlock them to the release mechanism and/or window fall prevention device.

**X3. SAMPLE FALL PREVENTION WINDOW GUARD**

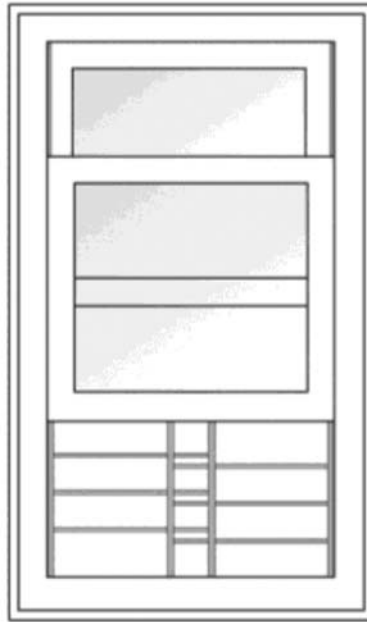

**X4. SAMPLE WINDOW FALL PREVENTION SCREEN**

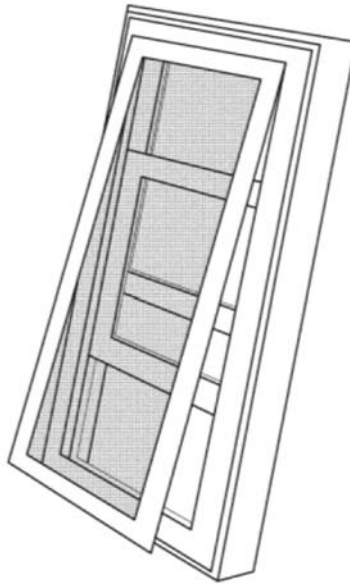



X5. SAMPLE WINDOW OPENING CONTROL DEVICES

NOTE X5.1—These are sample examples only and not limited to these specific designs.

X5.1 See Figs. X5.1-X5.5.

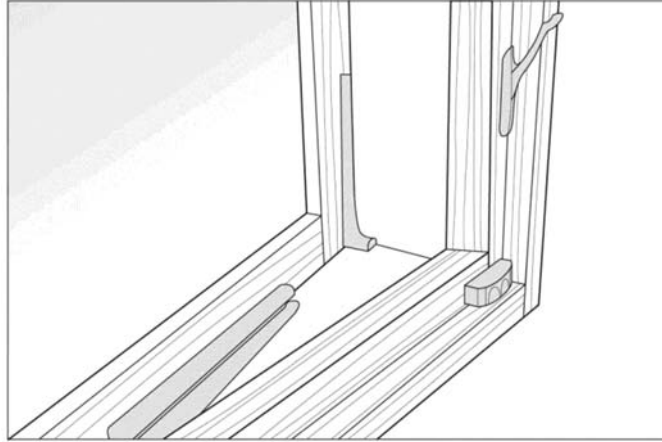

FIG. X5.1 Sample Casement Style Window Opening Control Device

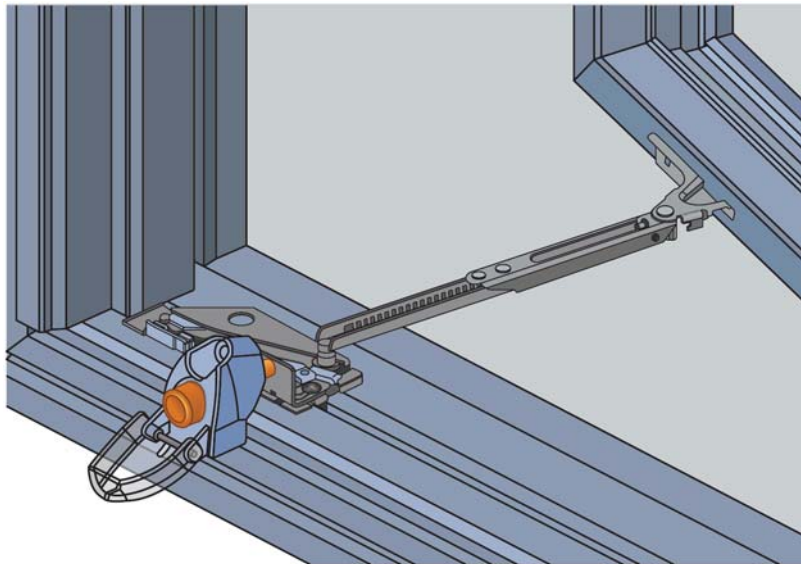

FIG. X5.2 Sample Casement Style Window Opening Control Device

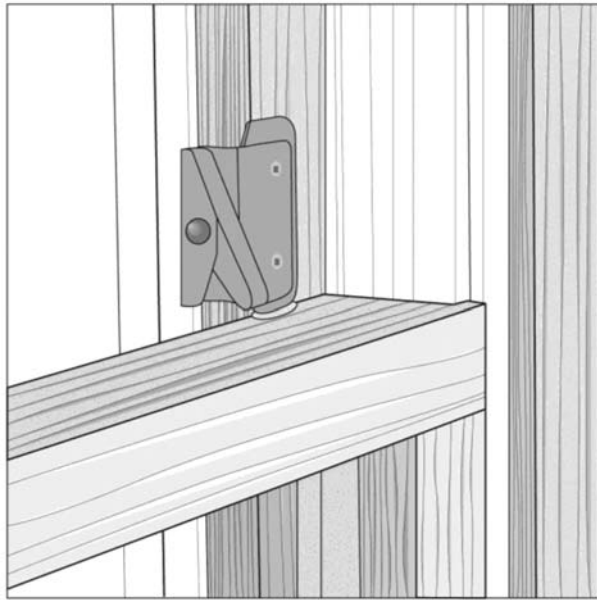

FIG. X5.3 Sample Hung (Single or Double) Style Window Opening Control Device

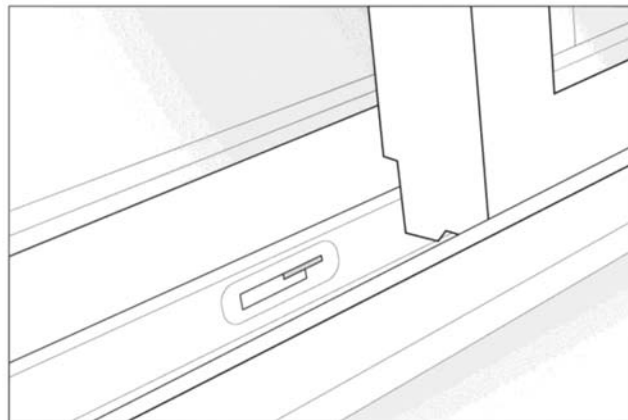
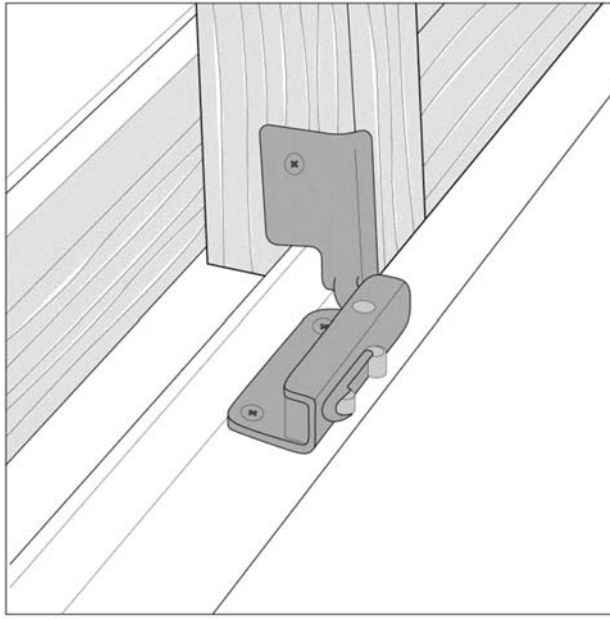

FIG. X5.4 Sample Gliding Window Style Window Opening Control Device



**FIG. X5.5 Sample Gliding Window Style Window Opening Control Device**

*ASTM International takes no position respecting the validity of any patent rights asserted in connection with any item mentioned in this standard. Users of this standard are expressly advised that determination of the validity of any such patent rights, and the risk of infringement of such rights, are entirely their own responsibility.*

*This standard is subject to revision at any time by the responsible technical committee and must be reviewed every five years and if not revised, either reapproved or withdrawn. Your comments are invited either for revision of this standard or for additional standards and should be addressed to ASTM International Headquarters. Your comments will receive careful consideration at a meeting of the responsible technical committee, which you may attend. If you feel that your comments have not received a fair hearing you should make your views known to the ASTM Committee on Standards, at the address shown below.*

*This standard is copyrighted by ASTM International, 100 Barr Harbor Drive, PO Box C700, West Conshohocken, PA 19428-2959, United States. Individual reprints (single or multiple copies) of this standard may be obtained by contacting ASTM at the above address or at 610-832-9585 (phone), 610-832-9555 (fax), or [service@astm.org](mailto:service@astm.org) (e-mail); or through the ASTM website ([www.astm.org](http://www.astm.org)). Permission rights to photocopy the standard may also be secured from the Copyright Clearance Center, 222 Rosewood Drive, Danvers, MA 01923, Tel: (978) 646-2600; <http://www.copyright.com/>*