



Standard Specification for Square Drive Interconnections on Surgical Instruments¹

This standard is issued under the fixed designation F2062; the number immediately following the designation indicates the year of original adoption or, in the case of revision, the year of last revision. A number in parentheses indicates the year of last reapproval. A superscript epsilon (ϵ) indicates an editorial change since the last revision or reapproval.

1. Scope

1.1 This specification applies to interconnections of surgical instruments used for drilling, tapping, driving, or placing of medical devices during surgery.

1.2 This specification includes dimensions and tolerances for both driving and driven elements.

1.3 The specifications given in ASME B107.4M-1995 are designed for industrial applications and are considered too loose for surgical applications. Springs used for industrial applications are generally made from carbon steel and are capable of higher loads than their stainless steel counterparts. The specifications given in this standard have been written to lessen the chance of accidental disengagement of surgical instruments. This accidental disengagement could injure the patient or end user, or damage or contaminate the instrument.

1.4 The values stated in either SI units or inch-pound units are to be regarded separately as standard. The values stated in each system may not be exact equivalents; therefore, each system shall be used independently of the other. Combining values from the two systems may result in non-conformance with the standard.

2. Referenced Documents

2.1 *ASTM Standards:*²

F899 Specification for Wrought Stainless Steels for Surgical Instruments

2.2 *Other Standard:*

ASME B107.4M-1995 (Revision of ANSI B107.4-1982), Driving and Spindle Ends for Portable Hand, Impact, Air,

and Electric Tools Percussion Tools Excluded³

3. Terminology

3.1 *Definitions of Terms Specific to This Standard:*

3.1.1 *drilling*—the act of forming a hole.

3.1.2 *driving*—the act of turning, pushing, or pulling a surgical instrument to place a medical device during surgery.

3.1.3 *square drive*—a male or female interconnection with four driving surfaces that are of equal width and perpendicular to each other.

3.1.4 *tapping*—the act of forming threads.

4. Material

4.1 This specification is intended to apply only to stainless steel instruments that conform to Specification **F899**. If other types of materials are used to interconnect with stainless steel instruments, then they should adhere to this specification.

5. Gauge Use and Design

5.1 **Tables 1-8** are descriptive and not restrictive, and are not intended to preclude the manufacture of product or gauges which are otherwise in accordance with this specification.

5.2 Manufacturers may use gauges with tighter dimensions or tolerances than shown herein to ensure device acceptance.

5.3 The extreme size for all limit (GO and NO-GO) gauges shall not exceed the extreme limits of interconnections specified within this specification. All variations (manufacturing tolerance, calibration error, wear allowance, and so forth) in the gauges, whatever their cause or purpose, shall bring these gauges within the extreme limits of the gauge size specified in this specification. Thus, a gauge representing a minimum limit may be larger, but never smaller, than the minimum size specified for the interconnection in this specification; likewise, a gauge representing a maximum limit may be smaller, but never larger, than the maximum size specified for the interconnection in this specification.

6. Keywords

6.1 instrument; interconnection; square drive; surgical

³ Available from American National Standards Institute (ANSI), 25 W. 43rd St., 4th Floor, New York, NY 10036, <http://www.ansi.org>.

¹ This specification is under the jurisdiction of ASTM Committee F04 on Medical and Surgical Materials and Devices and is the direct responsibility of Subcommittee F04.33 on Medical/Surgical Instruments.

Current edition approved June 1, 2011. Published July 2011. Originally approved in 2000. Last previous edition approved in 2006 as F2062 – 00 (2006). DOI: 10.1520/F2062-00R11.

² For referenced ASTM standards, visit the ASTM website, www.astm.org, or contact ASTM Customer Service at service@astm.org. For *Annual Book of ASTM Standards* volume information, refer to the standard's Document Summary page on the ASTM website.

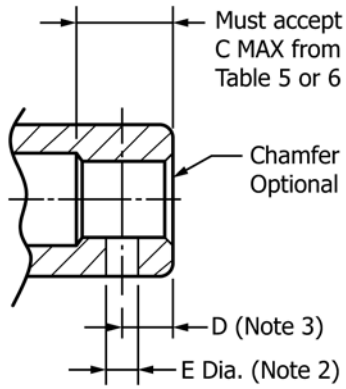

DESIGN A
CROSS HOLE TYPE

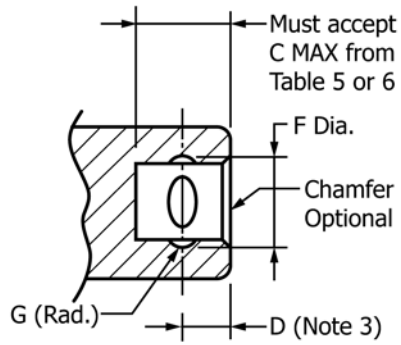

DESIGN B
RECESS TYPE

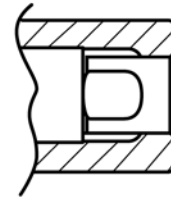
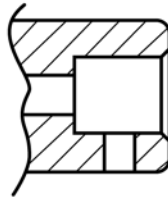
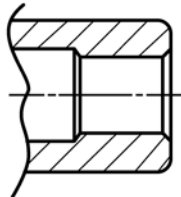
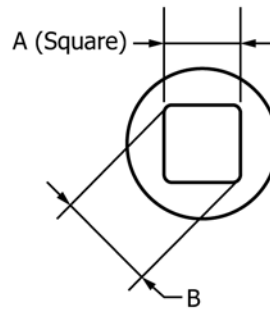

OPTIONAL CROSS SECTIONS

NOTES:

- (1) Square tolerances shall be such as to insure acceptance when gauged with gages conforming to Table 2.
- (2) Design A requires cross hole to be on one, two, or four sides. Recess Design B must require radius G to be on all four sides.
- (3) D MAX (Tables 1 & 2) doesn't equal D MIN (Tables 5 & 6); however, due to edge radius, plunger diameter, and square dimension interactions, no interference or interchangeability problem exists.

TABLE 1 Square Drive Specifications—Female End, mm

Drive Size		A (square)		B	D (Note 3)		E (Note 2)	F (diameter)		G (radius)	
mm	in.	max	min	min	max	min	min	max	min	max	min
4.76	0.1875	4.88	4.80	6.68	3.30	3.05	1.98	6.25	6.15	1.32	1.07
6.35	0.2500	6.48	6.38	8.51	3.94	3.43	2.29	7.75	7.49	1.73	1.47
9.53	0.3750	9.70	9.60	13.13	5.84	5.33	4.32	10.92	10.41	2.41	2.16

TABLE 2 Square Drive Specifications—Female End, in.

Drive Size		A (square)		B	D (Note 3)		E (Note 2)	F (diameter)		G (radius)	
in.	mm	max	min	min	max	min	min	max	min	max	min
0.1875	4.76	0.192	0.189	0.263	0.130	0.120	0.078	0.246	0.242	0.052	0.042
0.2500	6.35	0.255	0.251	0.335	0.155	0.135	0.090	0.305	0.295	0.068	0.058
0.3750	9.53	0.382	0.378	0.517	0.230	0.210	0.170	0.430	0.410	0.095	0.085

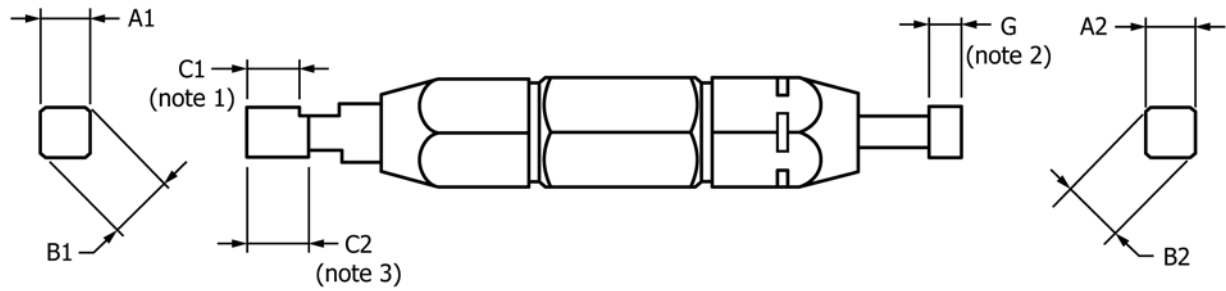

NOTES:

- (1) Minimum length requirement from table 5 or 6.
- (2) Minimum length for NO GO gage.
- (3) Optional maximum length from table 5 or 6.

TABLE 3 Square Drive Gauge Specifications—Female End, mm

Drive Size		A1	A2	B1	B2	C1	C2	G
mm	in.	+0.005 -0.000	+0.000 -0.005	+0.005 -0.005	+0.038 -0.038	+0.005 -0.000	+0.000 -0.005	min
4.76	0.1875	4.801	4.877	6.680	6.553	6.350	6.604	1.981
6.35	0.2500	6.375	6.477	8.509	8.331	7.366	7.874	2.286
9.53	0.3750	9.601	9.703	13.132	13.005	10.592	11.100	4.318

TABLE 4 Square Drive Gauge Specifications—Female End, in.

Drive Size		A1	A2	B1	B2	C1	C2	G
mm	in.	+0.0002 -0.0000	+0.0000 -0.0002	+0.0002 -0.0002	+0.0015 -0.0015	+0.0002 -0.0000	+0.0000 -0.0002	min
0.1875	4.76	0.1890	0.1920	0.2630	0.2580	0.2500	0.2600	0.0780
0.2500	6.35	0.2510	0.2550	0.3350	0.3280	0.2900	0.3100	0.900
0.3750	9.53	0.3780	0.3820	0.5170	0.5120	0.4170	0.4370	0.1700

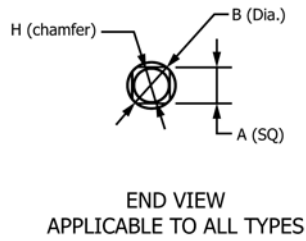
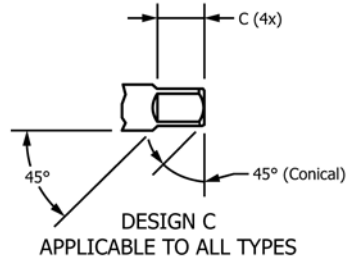
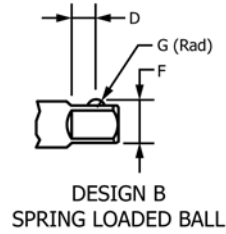
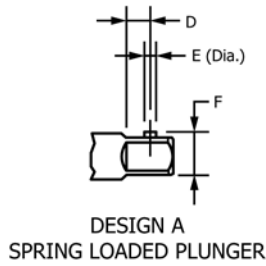

TABLE 5 Square Drive Specifications—Male End, mm

Drive Size		A (square)		B (dia)	C		D (Note 1)		E	F (lock height)		G (radius)		H
mm	in.	max	min	±0.002	max	min	max	min	min	max	min	max	min	max
4.76	0.1875	4.75	4.70	6.35	6.60	6.35	3.43	3.18	5.33	5.59	5.33	1.30	1.17	4.50
6.35	0.2500	6.35	6.30	7.92	7.87	7.37	4.19	3.81	6.86	7.36	6.86	1.70	1.57	6.10
9.53	0.3750	9.53	9.45	12.70	11.10	10.59	5.56	5.44	10.34	10.97	10.34	2.49	2.36	9.27

TABLE 6 Square Drive Specifications—Male End, in.

Drive Size		A (square)		B (dia)	C		D (Note 1)		E	F (lock height)		G (radius)		H
in.	mm	max	min	±0.002	max	min	max	min	min	max	min	max	min	max
0.1875	4.76	0.187	0.185	0.250	0.260	0.250	0.135	0.125	0.210	0.220	0.210	0.051	0.046	0.177
0.2500	6.35	0.250	0.248	0.312	0.310	0.290	0.165	0.150	0.270	0.290	0.270	0.067	0.062	0.240
0.3750	9.53	0.375	0.372	0.500	0.437	0.417	0.219	0.214	0.407	0.432	0.407	0.098	0.093	0.365

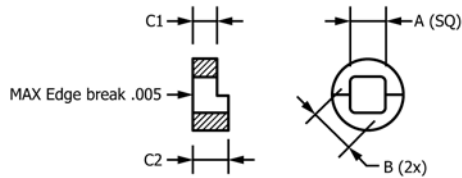
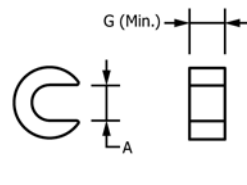
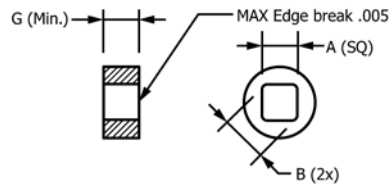

TABLE 7 Square Drive Gauge Specifications—Male End, mm

Drive Size		A1	A2	B1	C1	C2	G
mm	in.	+0.005	+0.000	min	+0.005	+0.000	min
		-0.000	-0.005		-0.000	-0.005	
4.76	0.1875	4.750	4.699	6.680	6.350	6.604	1.981
6.35	0.2500	6.350	6.299	8.509	7.366	7.874	2.286
9.53	0.3750	9.525	9.449	13.132	10.592	11.100	4.318

TABLE 8 Square Drive Gauge Specifications—Male End, in.

Drive Size		A1	A2	B	C1	C2	G
mm	in.	+0.0002 –0.0000	+0.0000 –0.0002	min	+0.0002 –0.0000	+0.0000 –0.0002	min
0.1875	4.76	0.1870	0.1850	0.2630	0.2500	0.2600	0.0780
0.2500	6.35	0.2500	0.2480	0.3350	0.2900	0.3100	0.0900
0.3750	9.53	0.3750	0.3720	0.5170	0.4170	0.4370	0.1700

APPENDIX

(Nonmandatory Information)

X1. RATIONALE

X1.1 The objective of this specification is the provision of guidelines for the physical characteristics of square drive interconnections specifically used for medical device applications. This specification identifies those factors felt to be important to ensure compatibility of square drive interconnections made by various manufacturers.

X1.2 Not all stainless steels listed in Specification **F899** may be appropriate for this application.

ASTM International takes no position respecting the validity of any patent rights asserted in connection with any item mentioned in this standard. Users of this standard are expressly advised that determination of the validity of any such patent rights, and the risk of infringement of such rights, are entirely their own responsibility.

This standard is subject to revision at any time by the responsible technical committee and must be reviewed every five years and if not revised, either reapproved or withdrawn. Your comments are invited either for revision of this standard or for additional standards and should be addressed to ASTM International Headquarters. Your comments will receive careful consideration at a meeting of the responsible technical committee, which you may attend. If you feel that your comments have not received a fair hearing you should make your views known to the ASTM Committee on Standards, at the address shown below.

This standard is copyrighted by ASTM International, 100 Barr Harbor Drive, PO Box C700, West Conshohocken, PA 19428-2959, United States. Individual reprints (single or multiple copies) of this standard may be obtained by contacting ASTM at the above address or at 610-832-9585 (phone), 610-832-9555 (fax), or service@astm.org (e-mail); or through the ASTM website (www.astm.org). Permission rights to photocopy the standard may also be secured from the Copyright Clearance Center, 222 Rosewood Drive, Danvers, MA 01923, Tel: (978) 646-2600; http://www.copyright.com/