



# Standard Consumer Safety Specification for Hand-Held Infant Carriers<sup>1</sup>

This standard is issued under the fixed designation F2050; the number immediately following the designation indicates the year of original adoption or, in the case of revision, the year of last revision. A number in parentheses indicates the year of last reappraisal. A superscript epsilon ( $\epsilon$ ) indicates an editorial change since the last revision or reappraisal.

## INTRODUCTION

This consumer safety specification is intended to mitigate potential safety hazards associated with a child's use of a hand-held infant carrier and thereby minimize the risk of injury or death. The specific hazards addressed by this standard are carrier handle strength to support the occupant, product tip over, and falls from elevated surfaces.

### 1. Scope

1.1 This consumer safety specification establishes performance requirements, test methods, and marking requirements to promote safe use of a hand-held infant carrier by an occupant and caregiver.

1.2 This consumer safety specification is intended to minimize the risk of incidents to an occupant resulting from normal use and reasonably foreseeable misuse or abuse of a hand-held infant carrier.

1.3 No hand-held infant carrier produced after the approval date of this consumer safety specification, either by label or other means, shall indicate compliance with this specification, unless it conforms to all requirements contained herein.

1.4 This consumer safety specification is not intended to address accidents and injuries resulting from the interaction of other persons with the child occupant in a hand-held infant carrier or the accidents resulting from abuse and misuse by children able to walk.

1.5 This consumer safety specification is not intended to address incidents or injuries resulting from use of the product in a motor vehicle, nor is it intended to address any issues that may arise from the manufacturer meeting the certification requirements of 49 CFR 571.213 or other applicable add-on child restraint standards.

1.6 The values stated in inch-pound units are to be regarded as standard. The values given in parentheses are mathematical conversions to SI units that are provided for information only and are not considered standard.

1.7 The following precautionary caveat pertains only to the test method portion, Section 7, of this consumer safety specification: *This standard does not purport to address all of the safety concerns, if any, associated with its use. It is the responsibility of the user of this standard to establish appropriate safety and health practices and determine the applicability of regulatory limitations prior to use.*

### 2. Referenced Documents

#### 2.1 ASTM Standards:<sup>2</sup>

[D3359 Test Methods for Measuring Adhesion by Tape Test](#)  
[F963 Consumer Safety Specification for Toy Safety](#)

#### 2.2 Federal Regulations:<sup>3</sup>

- [16 CFR 1303 Ban of Lead-Containing Paint and Certain Consumer Products Bearing Lead-Containing Paint](#)
- [16 CFR 1500 Hazardous Substances Act Regulations including sections:](#)
  - [16 CFR 1500.48 Technical Requirements for Determining a Sharp Point in Toys or Other Articles Intended for Use by Children Under Eight Years of Age](#)
  - [16 CFR 1500.49 Technical Requirements for Determining a Sharp Metal or Glass Edge in Toys or Other Articles Intended for Use by Children Under Eight Years of Age](#)
  - [16 CFR 1500.50–51 Test Methods for Simulating Use and Abuse of Toys and Other Articles Intended for Use by Children](#)
  - [16 CFR 1501 Method for Identifying Toys and Other Articles Intended for Use by Children Under Three Years of Age Which Present Choking, Aspiration or Ingestion Hazards Because of Small Parts](#)

<sup>1</sup> This consumer safety performance specification is under the jurisdiction of ASTM Committee F15 on Consumer Products and is the direct responsibility of Subcommittee F15.21 on Infant Carriers, Bouncers and Baby Swings.

Current edition approved Feb. 1, 2016. Published February 2016. Originally approved in 2000. Last previous edition approved in 2013 as F2050 – 13a. DOI: 10.1520/F2050-16.

<sup>2</sup> For referenced ASTM standards, visit the ASTM website, [www.astm.org](http://www.astm.org), or contact ASTM Customer Service at [service@astm.org](mailto:service@astm.org). For *Annual Book of ASTM Standards* volume information, refer to the standard's Document Summary page on the ASTM website.

<sup>3</sup> *Code of Federal Regulations*, available from U.S. Government Printing Office, Washington, DC 20402.



FIG. 1 CAMI Infant Dummy, Mark II

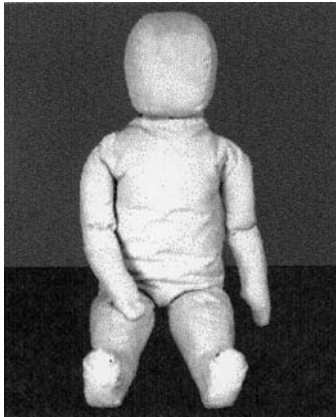

FIG. 2 CAMI Newborn Dummy

49 CFR 571.213 Federal Motor Vehicle Safety Standard (FMVSS) No. 213

2.3 Other References:

CAMI Infant Dummy, Mark II (see Fig. 1)<sup>4</sup>  
 CAMI Newborn Dummy (see Fig. 2)<sup>5</sup>

3. Terminology

3.1 Definitions:

3.1.1 *conspicuous*, *adj*—a label that is visible, when the infant carrier is in a manufacturer’s recommended use position,

<sup>4</sup> Department of Transportation Memorandum Report AAC-119-74-14, Revision II, Drawing No. SA-1001 by Richard Chandler, July 2, 1974, Federal Aviation Administration, Civil Aeromedical Institute, Protection and Survival Laboratory, Aeromedical Center, Oklahoma City, OK 73125.

<sup>5</sup> Drawing Numbers 126-0000 through 126-0015 (Sheets 1 through 3), 126-0017 through 126-0027, a parts list entitled “Parts List for CAMI Newborn Dummy”, and a construction manual entitled, “Construction of the Newborn Infant Dummy” (July 1992). Copies of the materials may be inspected at NHTSA’s Docket Section, 400 Seventh Street, SW, Room 5109, Washington, DC, or at the Office of the Federal Register, 800 North Capitol Street, NW, Suite 700, Washington, DC.

to a person standing near the infant carrier at any one position around the infant carrier but not necessarily visible from all positions.

3.1.2 *hand-held bassinet/criadle*, *n*—a freestanding product, with a rest/support surface to facilitate sleep (intended to be flat or up to 10° from horizontal), that sits directly on the floor, without legs or a stand, and has hand-holds or handle(s) intended to allow carrying an occupant whose torso is completely supported by the product.

3.1.3 *hand-held infant carrier*, *n*—a freestanding, rigid-sided product intended to carry an occupant whose torso is completely supported by the product to facilitate transportation by a caregiver by means of hand-holds or handles.

3.1.4 *hand-held infant carrier seat*, *n*—a hand-held infant carrier having a seat back that is intended to be in a reclined position (more than 10° from horizontal).

3.1.5 *manufacturer’s recommended use position(s)*, *n*—any position that is presented as a normal, allowable, or acceptable configuration for the use of the product by the manufacturer in any descriptive or instructional literature. This specifically excludes positions that the manufacturer shows in a like manner in its literature to be unacceptable, unsafe or not recommended.

3.1.6 *non-paper label*, *n*—any label material, such as plastic or metal, which either will not tear without the aid of tools or tears leaving a sharply defined edge.

3.1.7 *occupant*, *n*—that individual who is in a product that is set up in one of the manufacturer’s recommended use positions.

3.1.8 *paper label*, *n*—any label material which tears without the aid of tools and leaves a fibrous edge.

4. Calibration and Standardization

4.1 All testing shall be conducted on a concrete floor, which may be covered with 1/8-in. (3-mm) thick vinyl flooring covering, unless test instructs differently.

4.2 The product shall be completely assembled, unless otherwise noted, in accordance with the manufacturer’s instructions.

4.3 No testing shall be conducted within 48 h of manufacturing.

4.4 The product to be tested shall be in a room with ambient temperature of 73° ± 9°F (23° ± 5°C) for at least one hour prior to testing. Testing shall then be conducted within this temperature range.

4.5 All testing required by this specification shall be conducted on the same unit.

5. General Requirements

5.1 There shall be no hazardous sharp edges or points as defined by 16 CFR 1500.48 and 16 CFR 1500.49 before and after testing to this consumer safety specification.

5.2 There shall be no small parts as defined by 16 CFR 1501 before testing or liberated as a result of testing to this specification.

5.3 Product must comply with 16 CFR 1303.

5.4 *Wood Parts*—Prior to testing, any exposed wood parts shall be smooth and free from splinters.

5.5 *Openings*—Holes or slots that exist in the product in any manufacturer’s recommended use position, that are accessible to the toes and fingers of the occupant, and that extend entirely through a wall section of any rigid material less than 0.375-in. (9.53-mm) thick and admit a 0.210-in. (5.33-mm) diameter rod, shall also admit a 0.375-in. (9.53-mm) diameter rod. Holes or slots that are between 0.210 in. (5.33 mm) and 0.375 in. (9.53 mm) and have a wall thickness less than 0.375 in. (9.53 mm) but are limited in depth to 0.375 in. (9.53 mm) maximum by another rigid surface shall be permissible (see Fig. 3).

5.6 *Scissoring, Shearing, Pinching*—A product, when in a manufacturer’s recommended use position, shall be designed and constructed so as to prevent injury to the occupant from any scissoring, shearing, or pinching when members or components rotate about a common axis or fastening point, slide, pivot, fold, or otherwise move relative to one another. Scissoring, shearing, or pinching that may cause injury shall not be permissible when the edges of any rigid parts admit a probe greater than 0.210 in. (5.33 mm) and less than 0.375 in.

(9.53 mm) in diameter at any accessible point throughout the range of motion of such parts.

5.7 *Exposed Coil Springs*—Any exposed coil spring that is accessible to the occupant, having or capable of generating a space between coils of 0.210 in. (5.33 mm) or greater during testing in any manufacturer’s recommended use position(s) and tested in accordance with 7.2.2 and 7.2.3 shall be covered or otherwise designed to prevent injury from entrapment.

5.8 *Labeling:*

5.8.1 *Warning Labels*, whether paper or non-paper, shall be permanent when tested in accordance with 7.5.1 – 7.5.3.

5.8.2 Warning statements applied directly onto the surface of the product by hot stamping, heat transfer, printing, wood burning, etc., shall be permanent when tested in accordance with 7.5.4.

5.8.3 Non-paper labels shall not liberate small parts when tested in accordance with 7.5.5.

5.9 *Toys*—Toy accessories attached to, removable from, or sold with an infant carrier, as well as their means of attachment, must meet applicable requirements of Consumer Safety Specification F963.

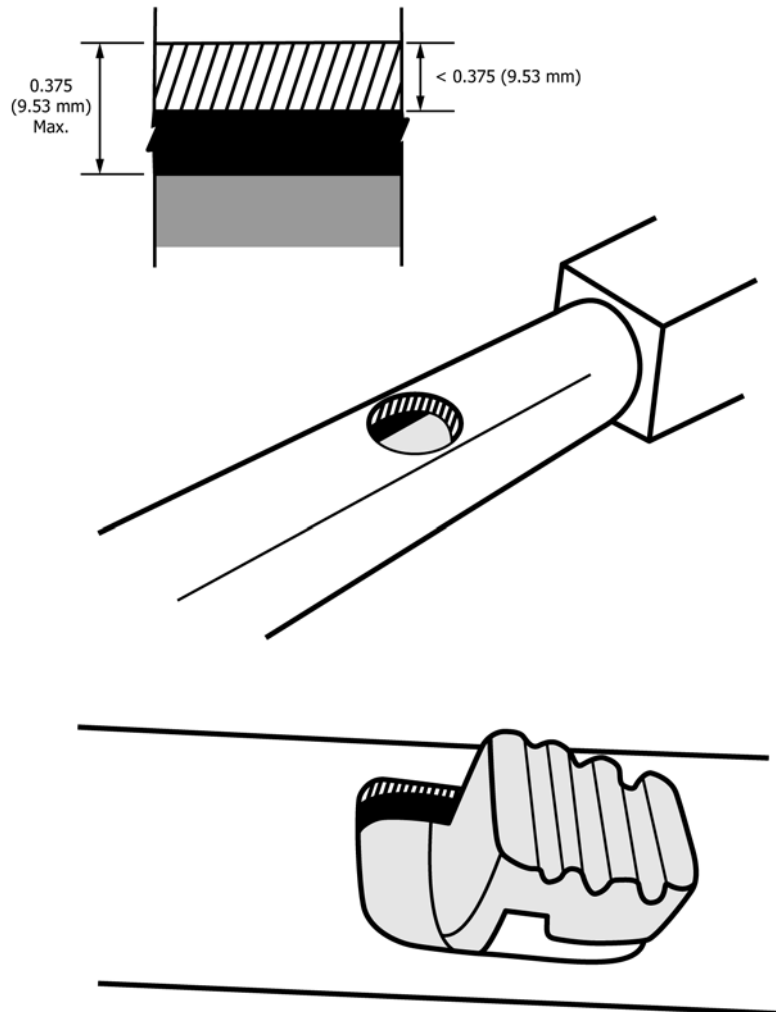

FIG. 3 Opening Example

5.10 *Protective Components*—If a child can grasp components between the thumb and forefinger, or teeth, such as caps, sleeves or plugs used for protection from sharp edges, points, or entrapment of fingers or toes or if there is at least a 0.040-in. (1.00-mm) gap between the component and its adjacent parent component, such component shall not be removed when tested in accordance with 7.4.

## 6. Performance Requirements

NOTE 1—The forces that are to be applied to the sample in the tests described in Section 7 of this specification are readily applied by means of a calibrated force gage.

6.1 *Carry Handle Auto-locking*—This requirement applies only to products having a rigid, adjustable carry handle that rotates about a singular axis and locks in the manufacturer’s designated carry position. The carry handle shall comply with 6.1.1, 6.1.2, or 6.1.3 when tested in accordance with 7.1.

6.1.1 The carry handle shall move unaided and lock into the manufacturer’s designated carry position or move unaided into a position that is obvious to the caregiver that the carry handle is not in the manufacturer’s designated carry position. The unaided movement shall occur within 5 s of the carry handle being placed into an unlocked position in 7.1.2 and 7.1.4, before attempting to lift the carrier in 7.1.3. The manufacturer’s designated carry position shall be clearly depicted in the instructional literature. A position obvious to the caregiver that is not the manufacturer’s designated carry position is defined as any position that is not suitable for carrying the occupant. For example, the carry handle comes to rest at the position adjacent to the top of the occupants head.

6.1.2 The carry handle shall lock in the manufacturer’s designated carry position when tested in accordance with 7.1.2 – 7.1.4.

6.1.3 The carry handle shall lock or be prevented from further movement by means of a mechanical stop in a position forward or rearward of the manufacturer’s designated carry position such that an unrestrained dummy does not fall out of the carrier when tested in accordance with 7.1.2 – 7.1.4.

6.2 *Carrying Handle Integrity*—All tests of 7.2 are to be performed on the same product, sequentially and without refurbishing or repositioning of adjustment. The carrier handle shall not break or unlatch on either one or both sides of the carrier when tested in accordance to 7.2.2 and 7.2.3. This requirement applies only to products having a rigid carry handle that rotates in head-to-foot and foot-to-head directions, and is capable of being adjusted from the manufacturer’s recommended carry position to any additional adjustment position.

6.3 *Restraint System*—A restraint system shall be provided to secure a child in the seated positions in any of the manufacturer’s recommended use positions except as outlined in 6.3.3.

6.3.1 For infant carriers that are not for use in motor vehicles, the restraint system shall include a waist restraint and crotch restraint. The crotch restraint’s use shall be mandatory when the waist restraint is in use.

6.3.2 The system and its closing means shall not slip more than 1 in. (25 mm), break, separate, or permit the removal of the test dummy when tested in accordance with 7.6.

6.3.3 Hand held bassinets/cribbs that are not for use in motor vehicles shall meet either 6.3.3.1 or 6.3.3.2.

6.3.3.1 Hand-held bassinets/cribbs shall not contain a restraint system.

6.3.3.2 Hand-held infant carrier seats that can be converted to a hand-held bassinet/cribble shall not be capable of being converted to a hand-held bassinet/cribble without the harness first being made inaccessible to the occupant when in the bassinet/cribble mode.

6.3.3.3 *Rationale for 6.3.3*—Hand-held bassinets/cribbs as defined in 3.1.2 have been added to this standard because bassinet/cribble products that do not have legs and sit directly on the floor are excluded from the ASTM bassinet/cribble standard. The restraint system requirements were added to extend the nonallowance of restraints from the bassinet/cribble standard to hand-held bassinet/cribbles, while at the same time allowing restraints for hand-held bassinet/cribble products that also have adjustment positions to hand-held infant carrier seats as defined in 3.1.4 that have a semi-reclined seating position. The subcommittee determined that the risk associated with strangulation in products configured for use in a bassinet mode (where the occupant is horizontal) far exceeded the potential for children falling out of the product during transportation.

6.4 *Slip Resistance*—An infant carrier shall not slip more than 0.12 in. (3.0 mm) within one minute when tested in accordance with 7.3.

## 7. Test Methods

### 7.1 *Carry Handle Auto-Locking Test:*

7.1.1 Without a dummy in the carrier, secure the harness and adjust the soft goods to accommodate an infant weighing 17 lb (development stage corresponding to the CAMI infant dummy Mark II) according to the manufacturer’s instructions. Adjust the harness such that it contacts the seating surface along its entire exposed length. Place the CAMI Infant dummy Mark II in the carrier on top of the buckled harness. Ensure that the dummy is firmly seated in the carrier against the harness with the rump in the seat bight and body fully seated against the seat back and bottom. Position the hands of the CAMI Infant dummy Mark II in front of the dummy at the head-to-toe centerline and attach the dummy’s hands together using duct tape or a similar means, such that the dummy’s arms are prevented from interfering with the carrier soft goods during the test.

NOTE 2—Positioning of the CAMI Infant dummy in the carrier is critical to ensure testing consistency and to eliminate test result variability that might be associated with the age/stiffness of the dummy. The dummy’s crotch should be pressed back against the buckled harness. The dummy’s taped hands should rest on its lap. The carrier padding should not prevent the dummy from movement during rotation of the seat during the test.

7.1.2 Starting with the carry handle locked in the manufacturer’s designated carry position, unlock the carry handle, and rotate the carry handle slightly rearward (toward the occupant’s head end of the carrier) into a position that is as close to the designated carry position as possible without the carry handle being locked in the designated carry position.

7.1.3 If the carry handle remains in the unlocked position, conduct the test in this section.

7.1.3.1 A test fixture having a vertically sliding, rigidly mounted support (Fig. 4) shall be used to apply the vertical lifting force in this test. The vertical lifting force shall be applied using a pneumatically powered cylinder. The pneumatic cylinder shall be capable of producing a gradual lifting speed within the range of 1.5 to 2.0 s over 12 in. (30.5 cm).

7.1.3.2 The vertical lifting force shall be applied using an  $18 \pm 0.25$  in. ( $46 \pm 0.6$  cm) length of child restraint webbing having a width of  $1.5 \pm 0.06$  in. ( $38 \pm 1.5$  mm) (Fig. 5). The fixture shall be fitted with a suitable clamping device that will prevent slippage of the webbing during the lift test. The webbing length shall allow a 4 to 6 in. distance between the top of the carrier handle and the clamping device when the webbing is in contact with the underside of the handle grip surface (Fig. 4).

7.1.3.3 Align the lengthwise centerline of the webbing at the horizontal mid-point of the carrier hand grip. Clamp the ends of the webbing in the fixture.

7.1.3.4 Raise the sliding support until the webbing contacts the underside of the grip surface and is taut. Apply a vertical force gradually over 1.5 to 2 s to lift the carrier 12 in. (30.5 cm) from the at rest position. If the carry handle remains in the

unlocked position after completion of lifting process, gradually apply a downward force to the occupant's feet end of the carrier at the side-to-side midpoint. The force shall be manually applied and shall be the minimum amount needed to cause rotation of the carrier seat.

7.1.4 If the product design allows, repeat 7.1.2 and 7.1.3, rotating the carry handle slightly forward (toward occupant's feet end of the carrier) into a position that is as close to the designated carry position as possible without the carry handle being locked in the manufacturer's designated carry position. If the carry handle remains in the unlocked position after completion of lifting process, gradually apply a downward force to the occupant's head end of the carrier at the side-to-side midpoint. The force shall be manually applied and shall be the minimum amount needed to cause rotation of the carrier seat.

7.2 *Carrying Handle Integrity*—For the tests in 7.2.2 and 7.2.3 the product shall be loaded to the manufacturer's maximum rated load or with CAMI dummy, whichever is greater. A weighted vest (see Fig. 6) with the CAMI dummy shall be used to achieve manufacturer's maximum rated load.

7.2.1 *Handle/Latch Preconditioning Cycling:*

7.2.1.1 Secure the infant carrier onto a test platform with the handle in the manufacturer's recommended carry position and so that the base of the carrier cannot move in the direction of the force being applied.

7.2.1.2 Apply an oscillating force to the handle in the forward and rearward direction normal to a plane established by the center line of the rotating axis of the handle and the center of the grip area of the handle as shown in Fig. 7. The oscillating force shall have a peak force of  $20 \pm 1$  lbf ( $89 \pm 4$  N) for 1000 cycles at a rate of 30 to 60 cycles per minute.

7.2.2 *Forward Facing Handle Endurance Test:*

7.2.2.1 Place the CAMI Infant Dummy, Mark II (see Fig. 1), with weighted vest as needed, into the infant carrier and secure the harness straps in accordance with the manufacturer's instructions. Pull the CAMI infant dummy's legs forward so that the dummy is tight against the crotch end of the harness.

7.2.2.2 With the carry handle in the manufacturer's recommended carry position, hang the carrier from the handle and determine the inclination of any convenient rigid surface on the carrier. This value of inclination will be used in the initial placement of the carrier in these endurance tests.

7.2.2.3 Place the conditioned infant carrier with the head end of the carrier against a pivot point on a vertical surface as shown in Fig. 8. The inclination of the carrier should be the same as measured while hanging freely.

7.2.2.4 Attach a chain, from the same vertical surface such that the chain angle is  $20^\circ \pm 2^\circ$  to the horizontal. Adjust the chain length if necessary.

7.2.2.5 Allow the product to hang in this position for 15 min.

7.2.2.6 Pull loose padding back from end of carrier and hang a test fixture with a drop weight of 1.2 lb (.54 kg) from end of infant carrier as shown in Fig. 8 at infant carrier major axis center line with the drop weight  $1 \pm 0.5$  in. ( $25 \pm 13$  mm) in from the end of the carrier. The fixture shall rest on the surface of the carrier and hang vertically ( $\pm 2^\circ$ ). See Fig. 9 for an example of an appropriate test fixture. Total weight of the

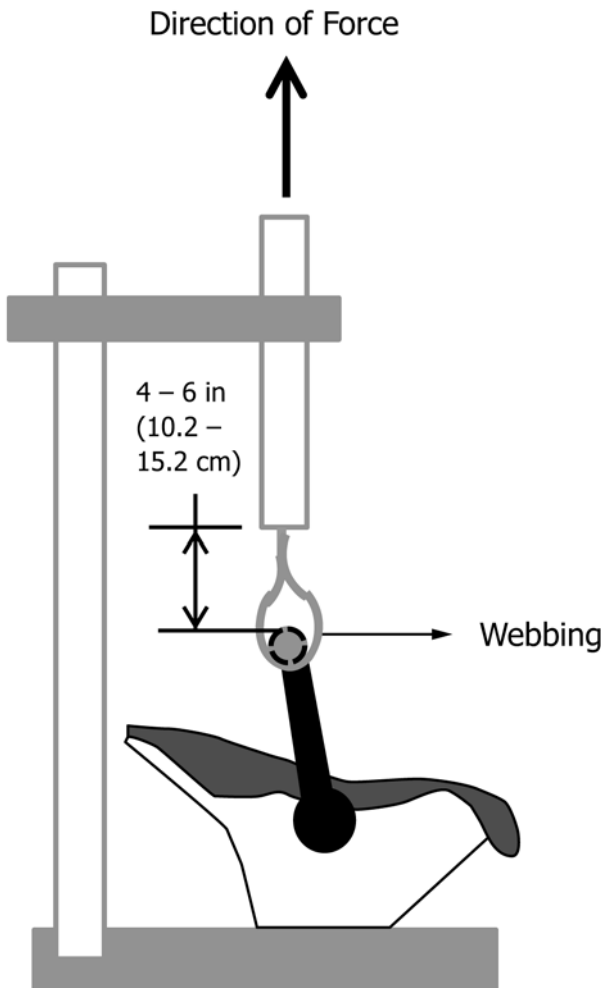

Handle Auto-lock Test  
FIG. 4 Lifting Fixture

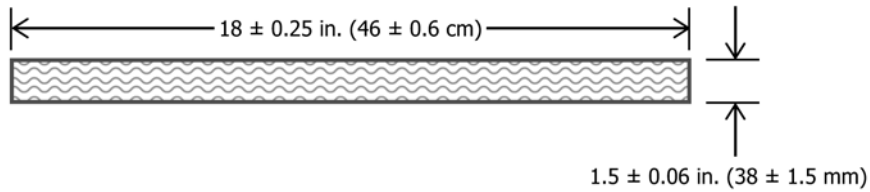

FIG. 5 Child Restraint Webbing

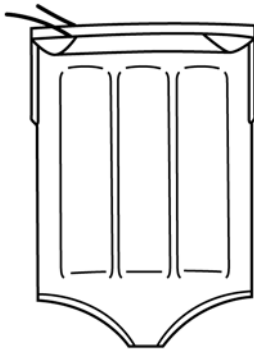

FIG. 6 Weighted Vest



FIG. 7 20-lbf Oscillating Force

test fixture without the drop weight shall be  $0.3 \pm 0.1$  lb ( $0.14 \pm 0.05$  kg). For carriers that do not have a suitable surface for hanging the drop weight fixture, a clamp, or other suitable means may be used to attach to the carrier, provided the test weight drops vertically.

7.2.2.7 Lift and allow drop weight to free fall from a height of 8 in. (20.3 cm) onto stop at end of rod. Repeat for a total of 50 cycles at a rate not exceeding 1 cycle per 5 s. Allow motion of the carrier to subside between drops. The test fixture can be repositioned during testing in order to maintain position within specification of 7.2.2.6.

NOTE 3—The padding that is intended to be pulled back from the end of the carrier in 7.2.2.6 and 7.2.3.6 should be loose padding and comfort foam only, not EPS, EPP, or other foams which may constitute some portion of the structure of the carrier.

7.2.3 Rearward Facing Handle Endurance Test:

7.2.3.1 Place the CAMI Infant Dummy, Mark II, with weighted vest as needed, into the infant carrier and secure the harness straps in accordance with the manufacturer’s instructions. Push the CAMI infant dummy’s head and torso rearward so that the dummy is tight against the seat back.

7.2.3.2 With the carry handle in the manufacturer’s recommended carry position, hang the carrier from the handle and determine the inclination of any convenient rigid surface on the carrier. This value of inclination will be used in the initial placement of the carrier in these endurance tests.

7.2.3.3 Place the conditioned infant carrier with the foot end of the carrier against a pivot point on a vertical surface as shown in Fig. 10. The inclination of the carrier should be the same as measured while hanging freely.

7.2.3.4 Attach a chain, from the same vertical surface such that the chain angle is between  $20 \pm 2^\circ$  to the horizontal. Adjust the chain length, if necessary.

7.2.3.5 Allow the product to hang in this position for 15 min.

7.2.3.6 Pull loose padding back from end of carrier and hang a test fixture with a drop weight of 1.2 lb (0.54 kg) from end of infant carrier as shown in Fig. 10 at infant carrier major axis centerline with the drop weight  $1 \pm 0.5$  in. ( $25 \pm 13$  mm) in from the end of the carrier. The fixture shall rest on the surface of the carrier and hang vertically ( $\pm 2^\circ$ ). See Fig. 9 for an example of an appropriate test fixture. Total weight of the test fixture without the drop weight shall be  $0.3 \pm 0.1$  lb ( $0.14 \pm 0.05$  kg). For carriers that do not have a suitable surface for hanging the drop weight fixture, a clamp, or other suitable means may be used to attach to the carrier, provided the test weight drops vertically.

7.2.3.7 Lift and allow drop weight to free fall from a height of 8 in. (20.3 cm) onto stop at end of rod. Repeat for a total of 50 cycles at a rate not exceeding 1 cycle per 5 s. All motion of the carrier to subside between drops. The test fixture can be repositioned during testing in order to maintain position within specification of 7.2.3.6.

7.3 Slip Resistance:

7.3.1 Test Surface:

7.3.1.1 The surface used to test slippage shall be an impregnated high-pressure laminate<sup>6</sup> of unspecified color with a smooth matte finish.

7.3.1.2 The laminate shall be mounted on a flat surface, with a thickness no less than  $\frac{3}{4}$  in. (19 mm), in accordance with the laminate manufacturer’s instruction.

7.3.1.3 Use of any products that will interfere with the performance of the laminate, that is, solvents or cleaners that leave residue or alter the surface finish is unacceptable.

7.3.1.4 Precautions should be taken to prevent the contamination of the testing surface. Graduation or pencil marks are unacceptable unless located in a position that never interferes with the performance of the test product, that is, along the edge of the surface.

7.3.2 Procedure:

7.3.2.1 Clean laminate surface of any dust or debris with a dry cloth.

<sup>6</sup> Formica, a registered trademark of Formica Corp., has been found suitable for this purpose.

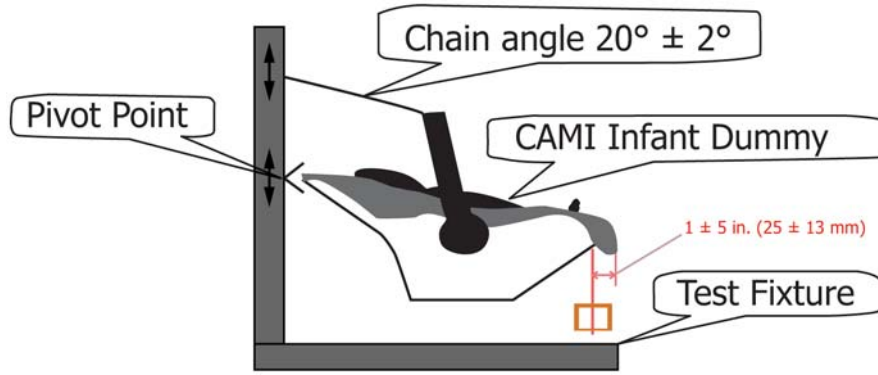

FIG. 8 Forward-Facing Test Set-Up, Loaded Condition

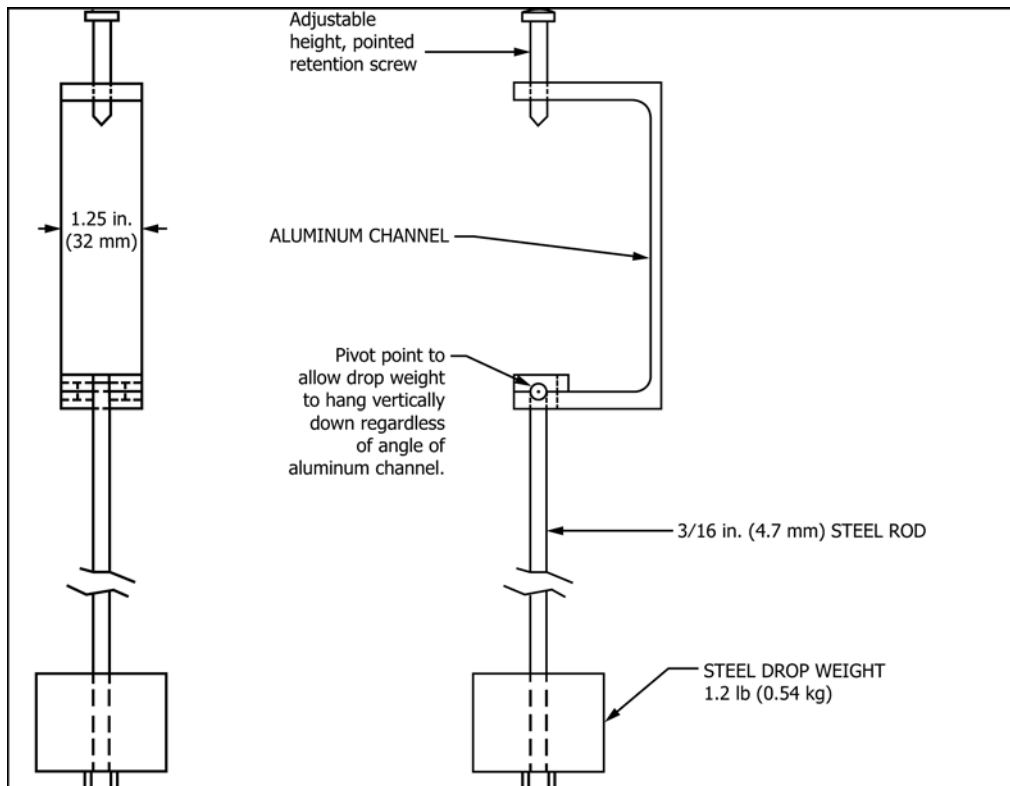

FIG. 9 Drop Weight Fixture

7.3.2.2 Incline the prepared laminate surface to 10°.

7.3.2.3 Clean slip resistant pads, feet, or any other objects on the infant carrier that come in contact with the inclined surface.

7.3.2.4 Place the CAMI newborn dummy (see Fig. 2) into the infant carrier and secure with the harness straps in accordance with the manufacturer’s instructions. If applicable, position the carry handle in the most upright or carry position.

7.3.2.5 *Forward Slip Resistance*—Place weighted carrier onto inclined surface with the front of carrier facing directly down the incline. Then, allow the product to remain in this position for one minute.

7.3.2.6 *Side Slip Resistance*—Rotate weighted carrier 90° clockwise and place on inclined surface. Then, allow the product to remain in this position for one minute.

7.3.2.7 *Backward Slip Resistance*—Place weighted carrier on inclined surface so that the carrier is facing directly up the incline. Then, allow the product to remain in this position for one minute.

7.4 *Removal of Protective Components:*

NOTE 4—Protective components shall be tested in accordance with each of the following methods in the sequence listed.

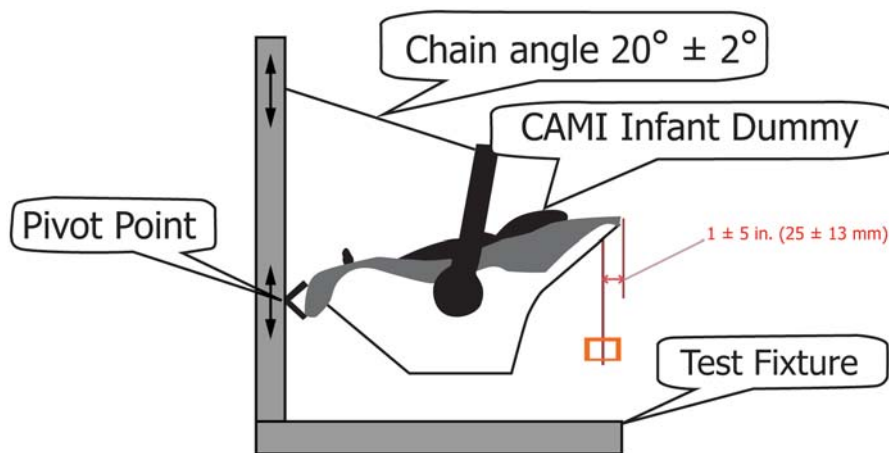

FIG. 10 Rearward-Facing Test Set-Up, Loaded Condition

7.4.1 *Torque Test*—A torque of 3 lbf-in. (0.3 N-m) shall be applied evenly within a period of 5 s in a clockwise direction until a rotation of 180° from the original position has been attained or 3 lbf-in. (0.3 N-m) has been reached. The torque or maximum rotation shall be maintained for an additional 10 s. The torque shall then be removed and the protective components permitted to return to a relaxed condition. This procedure shall then be repeated in a counterclockwise direction.

7.4.2 *Tension Test:*

7.4.2.1 Attach a force gage to the cap, sleeve, or plug by means of any suitable device. For protective components that cannot reasonably be expected to be grasped between thumb and forefinger or teeth on their outer diameter but have a gap of at least 0.040 in. (1 mm) between the rear surface of the protective component and the structural member of the infant carrier to which they are attached, a clamp, such as the one shown in Fig. 11, may be a suitable device.

15 lb Max TENSION



FIG. 11 Tension Test Adapter/Clamp

7.4.2.2 Assure that the attachment device does not compress or expand the protective component so that it hinders any possible removal.

7.4.2.3 Gradually apply a 15-lbf (67-N) force in the direction that would normally be associated with the removal of the protective component over a 5-s period and hold for an additional 10 s.

7.5 *Permanency of Labels and Warnings:*

7.5.1 A paper label (excluding labels attached by a seam) shall be considered permanent if, during an attempt to remove it without the aid of tools or solvents, it cannot be removed, it tears into pieces upon removal, or such action damages the surface to which it is attached.

7.5.2 A non-paper label (excluding labels attached by a seam) shall be considered permanent if, during an attempt to remove it without the aid of tools or solvents, it cannot be removed or such action damages the surface to which it is attached.

7.5.3 A warning label attached by a seam shall be considered permanent if it does not detach when subjected to a 15-lb (67-N) pull force applied in any direction using a 3/4-in. (19-mm)-diameter clamp surface.

7.5.4 *Adhesion Test for Warnings Applied Directly onto the Surface of the Product:*

7.5.4.1 Apply the tape test defined in Test Method B—Cross-Cut Tape Test of Test Methods D3359, eliminating parallel cuts.

7.5.4.2 Perform this test once in each different location where warnings are applied.

7.5.4.3 The warning statements will be considered permanent if the printing in the area tested is still legible and attached after being subjected to this test.

7.5.5 A non-paper label, during an attempt to remove it without the aid of tools or solvents, shall not be removed or shall not fit entirely within the small parts cylinder defined in 16 CFR 1501 if it can be removed.

7.6 *Restraint System Test:*

7.6.1 Secure the infant carrier so that it cannot move. Apply a force of 35 lbf (156 N) to a single attachment point of the restraint system in the normal use direction(s) in which stress



would be applied to that attachment. Gradually apply the force within 5 s, and maintain for an additional 10 s. Repeat a total of five times with a maximum interval of 2 s between tests. Repeat for each attachment point of the restraint system and each fastening device.

7.6.2 Place the CAMI Infant Dummy, Mark II in the infant carrier with the restraining system engaged according to the manufacturer’s instructions. Tighten the restraint system in such a manner that you can comfortably slide your little finger between the strap and the test dummy. Perform the following test without readjusting the restraining system. Gradually apply a pull force of 35 lbf (156 N) horizontally to either leg of the test dummy. Gradually apply the force within 5 s and maintain for an additional 10 s. Repeat this procedure a total of five times with a maximum of 2 s between test.

**8. Marking and Labeling**

8.1 Each product and the shipping container must have a permanent label or marking that identifies the name and address (city, state, and zip code) of the manufacturer, distributor, or seller.

8.2 A permanent code mark or other product identification shall be provided on the infant carrier and its package or shipping container, if multiple packaging is used. The code will identify the date (month and year) of manufacture and permit future identification of any given model.

8.2.1 The manufacturer shall change the model number whenever the infant carrier undergoes a significant structural or design modification or a change that affects its conformance to this consumer safety specification.

8.3 Each infant carrier shall be labeled with warning statements. The warning statements shall be in contrasting color(s), permanent, conspicuous, and in sans serif style font.

8.3.1 In warning statements, the symbol and the word **△ WARNING** shall be at least 0.2 in. (5 mm) high and shall appear at the top of the warning label. The remainder of the text shall be characters whose upper case shall be at least 0.1 in. (2.5 mm) high.

8.3.2 The warning statements shall address the following unless exact wording and content is specifically required:

8.3.2.1 Hand-held bassinets/cribels are exempt from this requirement. NEVER leave child unattended.

8.3.2.2 Suffocation Hazard: Infant carrier can roll over on soft surfaces and suffocate child. NEVER place carrier on beds, sofas, or other soft surfaces.

8.3.2.3 Strangulation Hazard: Carriers intended for use as infant restraint devices in motor vehicles shall contain the following warning label. This label requires exact language, including capitalized and bold text, and a specific location:



(1) The area of the pictogram is to be at least 1.09 in.<sup>2</sup> (706 mm<sup>2</sup>) while not exceeding the size of the airbag warning pictogram in the label required under 49 CFR 571.213. The message area in the label shall be no less than 4.65 in.<sup>2</sup> (30 cm<sup>2</sup>), while not exceeding the size of the airbag warning message area in the label required under 49 CFR 571.213.

(2) The harness in the pictogram shall be black on a white background and shall include a red circle and slash and green check mark, as shown in the illustration above.

(3) The heading area shall be yellow with the word “warning” and the alert symbol in black.

(4) The warning label shall be a separate and independent label from the airbag warning label required in 49 CFR 571.213.

(5) The warning label shall be permanently affixed to the outer surface of the cushion or padding in or adjacent to the area where a child’s head would rest, so that the label is plainly visible and easily readable.

(a) The pictogram can be customized to more accurately reflect the manufacturer’s product, but shall conform to the content shown in the pictogram.

8.3.2.4 Strangulation Hazard: The following warning is required only for carriers not intended for use in a motor vehicle. Hand-held bassinets/cribels are exempt from this requirement. This warning requires exact language:

Children have **STRANGLING** in loose or partially buckled harness straps. Fully restrain the child at all times.

8.3.2.5 Fall Hazard: Child’s activity can move carrier. NEVER place carrier on counter tops, tables, or any other elevated surface.

8.3.3 Infant carriers not intended for use as infant restraint devices in motor vehicles.

8.3.3.1 NEVER use this carrier as a means to transport an infant in a motor vehicle.

8.4 Any upholstery label required by law shall not be used to meet the requirements in Section 8.

**9. Instructional Literature**

9.1 Instructions must be provided with the infant carrier and shall be easy to read and understand. Assembly, maintenance,

cleaning, operating, and adjustment instructions and warnings, where applicable, must be included.

9.1.1 The instructions shall contain warning statements in accordance with 8.3.2. For carriers intended for use as infant restraint devices in motor vehicles, the warning statement contained in the warning label depicted in 8.3.2.3 must also be included. In addition, the instructions shall include the following statements:

9.1.1.1 Read all instructions before use of the infant carrier.

9.1.1.2 Keep instructions for future use.

9.1.1.3 Do not use the infant carrier if it is damaged or broken.

9.2 *Warning Statements Within the Instructional Literature:*

9.2.1 In warning statements, the symbol and the word  $\Delta$  WARNING shall be at least 0.2 in. (5 mm) high. The remainder of the text shall be characters whose upper case shall be at least 0.1 in. (2.5 mm) high.

9.2.2 The instructions must advise how the restraint system shall be used.

9.2.3 The instructions must indicate the manufacturer's recommended maximum height, age, or combination thereof of the occupant for which the infant carrier is intended.

## 10. Keywords

10.1 hand-held infant carriers

*ASTM International takes no position respecting the validity of any patent rights asserted in connection with any item mentioned in this standard. Users of this standard are expressly advised that determination of the validity of any such patent rights, and the risk of infringement of such rights, are entirely their own responsibility.*

*This standard is subject to revision at any time by the responsible technical committee and must be reviewed every five years and if not revised, either reapproved or withdrawn. Your comments are invited either for revision of this standard or for additional standards and should be addressed to ASTM International Headquarters. Your comments will receive careful consideration at a meeting of the responsible technical committee, which you may attend. If you feel that your comments have not received a fair hearing you should make your views known to the ASTM Committee on Standards, at the address shown below.*

*This standard is copyrighted by ASTM International, 100 Barr Harbor Drive, PO Box C700, West Conshohocken, PA 19428-2959, United States. Individual reprints (single or multiple copies) of this standard may be obtained by contacting ASTM at the above address or at 610-832-9585 (phone), 610-832-9555 (fax), or service@astm.org (e-mail); or through the ASTM website (www.astm.org). Permission rights to photocopy the standard may also be secured from the Copyright Clearance Center, 222 Rosewood Drive, Danvers, MA 01923, Tel: (978) 646-2600; <http://www.copyright.com/>*