



Standard Specification for Cooking Fire Suppression Blankets¹

This standard is issued under the fixed designation F1989; the number immediately following the designation indicates the year of original adoption or, in the case of revision, the year of last revision. A number in parentheses indicates the year of last reapproval. A superscript epsilon (ϵ) indicates an editorial change since the last revision or reapproval.

1. Scope

1.1 This specification covers requirements for cooking fire suppression blankets to extinguish accidental cooking fires.

1.2 This specification does not apply to cooking fire suppression blankets that: are made from asbestos; have sides of differing appearance, finish or color; have a performance that differs according to which side is used; or, are of metallic construction or component.

1.3 The values stated in SI units are to be regarded as the standard.

1.4 The following safety hazards caveat pertains only to the test methods portion of this specification, Section 4: *This standard does not purport to address all of the safety concerns, if any, associated with its use. It is the responsibility of the user of this standard to establish appropriate safety and health practices and determine the applicability of regulatory limitations prior to use.*

2. Terminology

2.1 *Definitions*—For the purpose of this specification, the following definition applies:

2.1.1 *fire blanket, n*—flexible sheet(s) of material intended to be used to extinguish small fires by smothering.

3. Physical Properties

3.1 *Size and Shape*—Cooking fire suppression blankets shall be rectangular or square, with no edge less than 0.91 ± 0.05 m (36 ± 2 in.).

3.2 *Mass*—Cooking fire suppression blankets shall have a mass not exceeding 2 kg (4.4 lb).

3.3 *Hand Holding Devices:*

3.3.1 Hand holding devices, if provided, shall consist of sewn in straps on both sides of the blanket to facilitate quick release. The strap length shall not be less than 100 mm (3.9 in.) or more than 200 mm (7.8 in.) in length, and easily grasped and

released when applying the blanket over a cooking fire. The straps may be made of any high strength material and shall be of contrasting color from the blanket itself.

3.3.2 Attention shall be paid to the design of any holding device to ensure ease of handling and hand release.

3.4 *Appearance and Bi-Lateral Use*—The two sides of a fire blanket shall be of identical appearance, finish or color and shall give the equivalent results when tested for compliance with Section 4.

NOTE 1—It is important not only that either side of fire blanket can be exposed to the fire or other hazard with equal effectiveness, but also that no doubt be created in the mind of the user at the moment of emergency use as to which side of the fire blanket to apply to the hazard.

3.5 *Resistance to Fraying or Tearing*—The edges of cooking fire suppression blankets shall not fray or tear during testing for compliance with 4.3.1, 4.3.2, 4.4.4, and 4.5.1.5.

4. Test Methods

4.1 *Sampling and Sequence of Testing:*

4.1.1 A minimum of nine cooking fire suppression blankets is required. Identify and mark the cooking fire suppression blankets as No. 1 to 9 and the two sides as (a) and (b).

4.1.1.1 Cooking fire suppression blankets which contain a seam shall be tested both on and off the seam and, where the seam is tested, in the most unfavorable condition. Tests shall be carried out using a single thickness of cooking fire suppression blankets.

4.1.2 Use any fire blanket as required for the nondestructive examinations required in Section 4. Use cooking fire suppression blankets No. 1, 2, and 3 for testing to 4.5.1 in the sequence of 1(a), 2(b), 3(a). Use cooking fire suppression blankets 4, 5 and 6 for testing to 4.4 in sequence of 4(a), 5(b), and 6(a). Use cooking fire suppression blankets 7, 8 and 9 for testing to 4.5.2 in sequence of 7(a), 8(b), and 9(a).

4.2 *Conditioning:*

4.2.1 Condition cooking fire suppression blankets for testing for 48 h so that they are in equilibrium with air at $20 \pm 5^\circ\text{C}$ and at a relative humidity of 50 to 70 %. After conditioning, do not expose the blanket to air at different temperature or relative humidity for longer than 5 min before testing. Keep the fire blanket in a sealed plastic bag or other conditioning container until testing if it is necessary to transport it any distance to the test site.

¹ This specification is under the jurisdiction of ASTM Committee F15 on Consumer Products and is the direct responsibility of Subcommittee F15.46 on Fire Suppression Towels.

Current edition approved April 1, 2013. Published August 2013. Originally approved in 1999. Last previous edition approved in 2005 as F1989 – 05. DOI: 10.1520/F1989-05R13.

4.2.2 Store fire blanket for testing in their containers, or in the recommended storage condition for 24 h immediately prior to the testing for conformity with the requirements of Section 4.

4.2.3 Except where otherwise specified, tests shall be carried out at $20 \pm 10^\circ\text{C}$.

4.3 General Tests:

4.3.1 Flexibility Test—Blankets shall be capable of being rolled without permanent deformation along any axis completely around a 50-mm diameter bar.

4.3.2 Ease of Removal Test—Cooking fire suppression blankets shall be designed and located in such a way that the user can remove, unfold, and make ready for use in not more than 4 s. The force required to remove the fire blanket from its container (if used) shall not exceed 80 N.

4.4 Electrical Resistance Test:

4.4.1 Principle—The electrical resistance of the fire blanket is measured between a negative electrode formed by a steel or aluminum-topped table and a flat rectangular conducting positive electrode.

4.4.2 Apparatus:

4.4.2.1 Table, with a steel or aluminum top.

4.4.2.2 Megohmmeter, 500 V, dc.

4.4.2.3 Flat Rectangular Conducting Positive Electrode, 450 by 150 mm, total mass of 5 kg (including metal base, backing support and insulating handle (see Fig. 1).

4.4.3 Procedure—Arrange the apparatus as shown in Fig. 1. Lay the fire blanket flat on the table and zero and operate the megohmmeter in accordance with the manufacturer's instruc-

tions. Move the instrument and the fire blanket as necessary, then check the whole surface area of the blanket. Test three cooking fire suppression blankets.

4.4.4 Interpretation of Results—A fire blanket is considered to be in conformance with this specification if the electrical resistance of the fire blanket is not less than $1\text{ M}\Omega$ at any point.

4.5 Fire Performance Tests:

4.5.1 Volatile Liquid Test Fires:

4.5.1.1 Fuel—The fuel shall be an aliphatic hydrocarbon of initial boiling point not less than 88°C and final boiling point not more than 105°C . It is not necessary to use fresh fuel for each test provided that the initial fuel temperature is $20 \pm 5^\circ\text{C}$.

4.5.1.2 Tray Dimensions and Quantity of Fuel—The dimensions of the welded 2-mm sheet steel circular cylindrical trays are given in Table 1.

4.5.1.3 Siting—Position the test tray on a 0.8-m high horizontal metal table, not smaller than the fire blanket to be tested and between 1.45 and 1.8 m square, equidistant from two opposite sides and so that the distance from one of the other two sides (Side (a)) to the far edge of the tray is $900 \pm 5\text{ mm}$ (see Fig. 2). Place the table in a room free from drafts, with sufficient ventilation to allow the fire to develop freely and to remove products of combustion. Ensure that the ambient temperature is between 10 and 30°C .

4.5.1.4 Procedure—Place in the tray sufficient water (half the fuel volume) to give an average depth of 15 mm. This is to counter any irregularities in the base. Place the fuel in the tray. After ignition, allow the fire to burn freely for 1 min, then apply the fire blanket under test as symmetrically as possible to

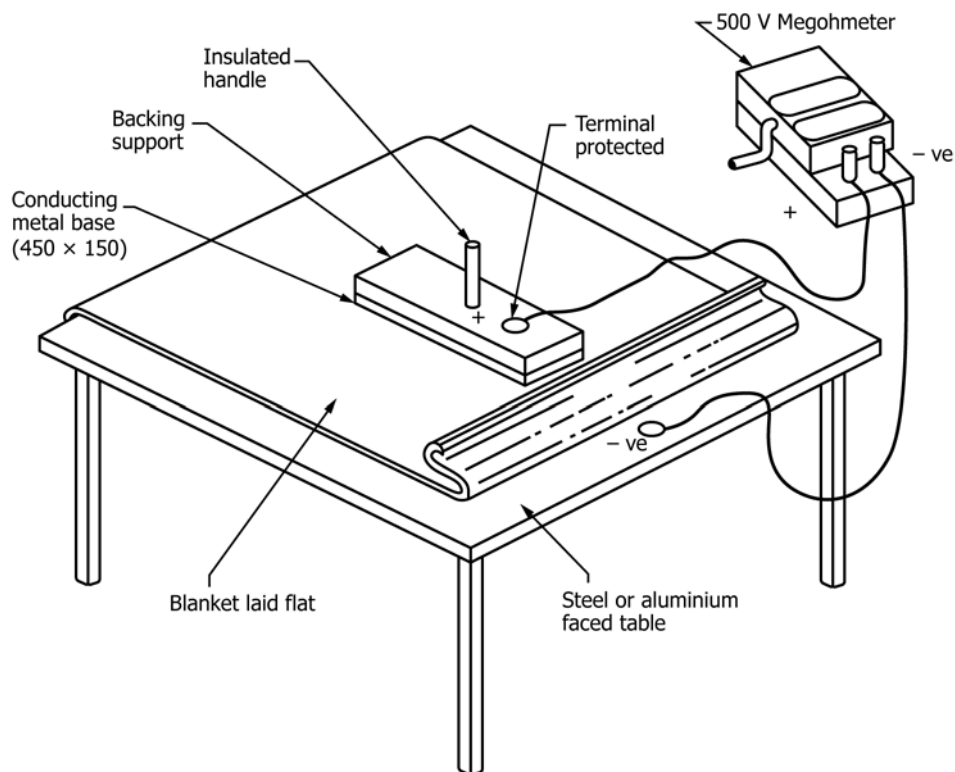

NOTE 1—All dimensions are in millimetres.

FIG. 1 Typical Arrangement for the Electrical Test

TABLE 1 Tray Dimensions and Quantity of Fuel

Designation	Fuel Volume, L	Tray Diameter, mm	Tray Depth, mm	Approximate Surface Area of Fire, m ²
Cooking fire suppression blankets	3	348 ± 5	100 ± 5	0.094

the fire from Side (a) of the table.² The fire is considered to be extinguished if no flames are visible 3 min after ignition. Some fuel shall remain at the end of the test, indicating that the fire has extinguished, not merely starved of fuel. Test three cooking fire suppression blankets each once.

NOTE 2—Attention is drawn to the necessity for taking precautions to safeguard the health of personnel conducting the tests against the risk of fire and inhalation of smoke or any toxic products of combustion.

4.5.1.5 *Interpretation of Results*—Cooking fire suppression blankets shall be capable of extinguishing the volatile liquid fire. All three tests shall be successful and the cooking fire suppression blankets shall remain whole and not ignite during the test.

4.5.2 *Home Cooking Fire*—Repeat test as outlined in 4.5.1, except:

4.5.2.1 Use a 30 in. electrical residential cooking stove,

4.5.2.2 Place the pan on larger back electrical burner,

4.5.2.3 Ensure that range is flush with 5/8 in. gypsum wall behind range,

4.5.2.4 Use a standard commercial cooking pan with a handle, 7 in. diameter, 3½ in. deep, with a 5 to 7 in. handle,

4.5.2.5 Fill pan half full with cooking oil,

4.5.2.6 Position pan so that the handle is pointing 90° to the front, and

4.5.2.7 A30 in. wide by 18 in. deep exhaust vent hood is located 24 in. directly above the stove.

4.5.2.8 *Interpretation of Results*—Cooking fire suppression blankets shall be capable of extinguishing the home cooking oil fire. All three tests shall be successful and the fire blanket shall remain whole and not ignite during the test.

4.5.3 *Cooking Oil Test Fires*:

4.5.3.1 *Fuel*—The fuel shall be 100 % edible Soya bean oil, free from additives with a minimum auto-ignition temperature of 600°F. Fresh fuel shall be used for each test.

4.5.3.2 *Tray Dimensions and Quantity of Fuel*—As defined in 4.5.1.1 and Table 1.

4.5.3.3 *Tray Support Stand*—The tray support stand shall be of square four-legged form, constructed of 25 by 25 mm metal angle. The height shall be 140 ± 5 mm. The square side shall be 240 ± 5 mm for the tray, but the diagonal dimension shall not exceed the diameter of the tray used.

4.5.3.4 *Siting*—Position the test tray centrally on the supporting stand shown in Fig. 3, on a 0.8 m high horizontal metal table, not smaller than the blanket to be tested and between 1.45 and 1.8 m square, equidistant from two opposite sides and so that the distance from one of the other sides (Side (a)) to the far edge of the tray is 750 mm (see Fig. 3). Place the table in

a room free from drafts, with sufficient ventilation to allow the fire to develop freely and to remove products of combustion. The ambient temperature shall be between 10 and 30°C.

4.5.3.5 *Procedure*—Place the fuel in the tray, free of residue from previous tests. Using a gas burner centrally positioned under the tray, heat the oil so that its temperature, measured centrally, increases at about 10°C per min and self-ignites within 25 to 35 min. Turn off the gas supply. Allow the fire to burn freely for 2 min after ignition. Immediately apply the blanket under test as symmetrically as possible to the fire from Side (a) of the table.² Test three blankets each once. The fire is considered to be extinguished if there are no visible flames 17 min after ignition. Some fuel shall remain at the end of the test, that is, the fire shall be extinguished and not merely starved of fuel.

NOTE 3—Attention is drawn to the necessity for taking precautions to safeguard the health of personnel conducting the tests against the risk of fire, spillage of the hot oil, and the inhalation of smoke or toxic products of combustion.

4.5.3.6 *Interpretation of Results*—Cooking fire suppression blankets shall be capable of extinguishing the cooking oil fire. All three tests shall be successful and the fire blanket shall remain whole and not ignite during the test.

5. Product and Package Marking

5.1 *Shipping Container*—The shipping container shall include:

5.1.1 The manufacturer's or vendor's name and address,

5.1.2 The information specified in or wording which relates the fire towel to the container or the instruction sheet, or both, and

5.1.3 The number and date of this ASTM specification.

5.2 *Fire Blanket Container*—The cooking fire suppression blanket shall be packaged in such a manner that it is instantly identifiable for what it is and for instant removal in the event of an accidental cooking fire. There is no restriction on the means of packaging the blanket, but every container should be capable of either being installed on the kitchen walls or placed on countertops in the proximity of the cooking area and meet ease of removal criteria noted in 4.3.2.

5.3 *Shipping or Instruction Sheet*—Each shipping container, or instruction sheet, for fixing near to the storage position of the fire blanket, shall be marked with the following:

5.3.1 The words *fire blanket* on the front,

5.3.2 Instructions for use and mounting, preferably incorporating pictograms on the front,

5.3.3 Minimum time for removal from the fire of 20 min,

5.3.4 The manufacturer's or vendor's name and address,

5.3.5 The model or other identification of the fire blanket,

5.3.6 The size of the fire blanket, cooking fire suppression blankets shall be rectangular or square, with no edge less than 0.91 ± 0.05 m (36 ± 2 in.),

5.3.7 Indication that the fire blanket is not reusable and should be discarded after use,

5.3.8 Checking, maintenance and servicing instructions, including when to discard if damaged or contaminated, and

5.3.9 The designation and date of this ASTM specification.

² See Appendix X1 for a device that can be used as an alternative to manual placement of the fire blanket over the fire.

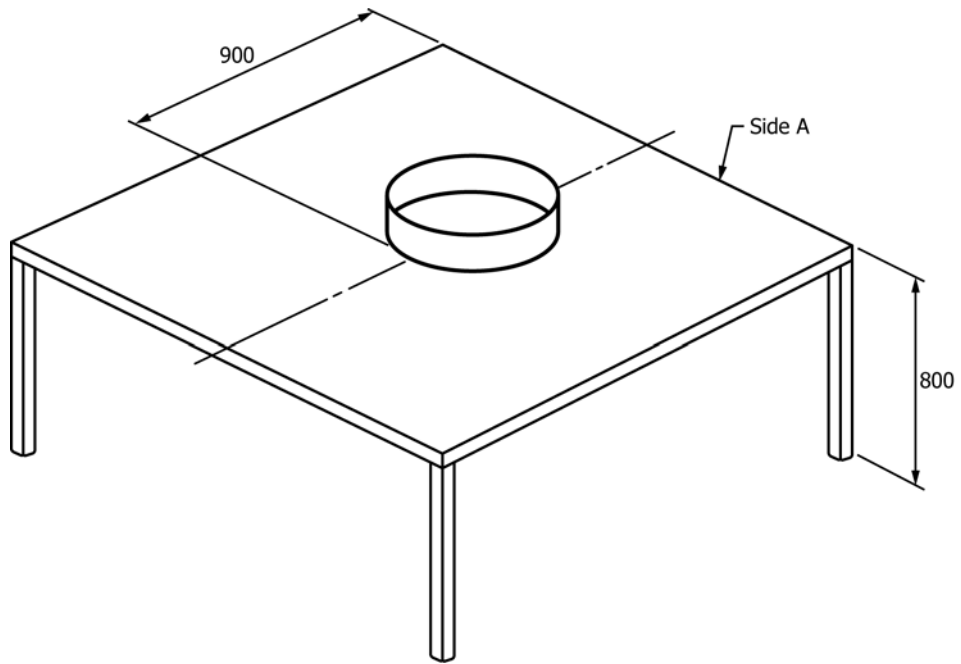

NOTE 1—All dimensions are in millimetres.

FIG. 2 Typical Arrangement for Volatile Liquid Test Fire

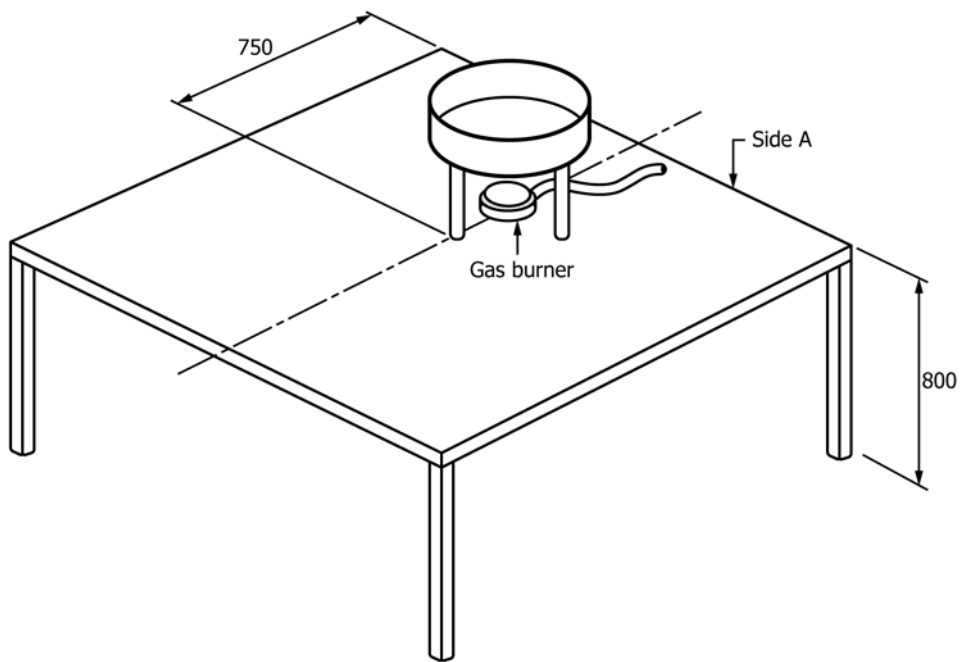

NOTE 1—All dimensions are in millimetres.

FIG. 3 Typical Arrangement for Cooking Oil Test

6. Keywords

6.1 cooking fires; cooking fire suppression blankets; fire blankets; fire suppression; safety standards

APPENDIX

(Nonmandatory Information)

X1. SUGGESTED ALTERNATE DEVICE

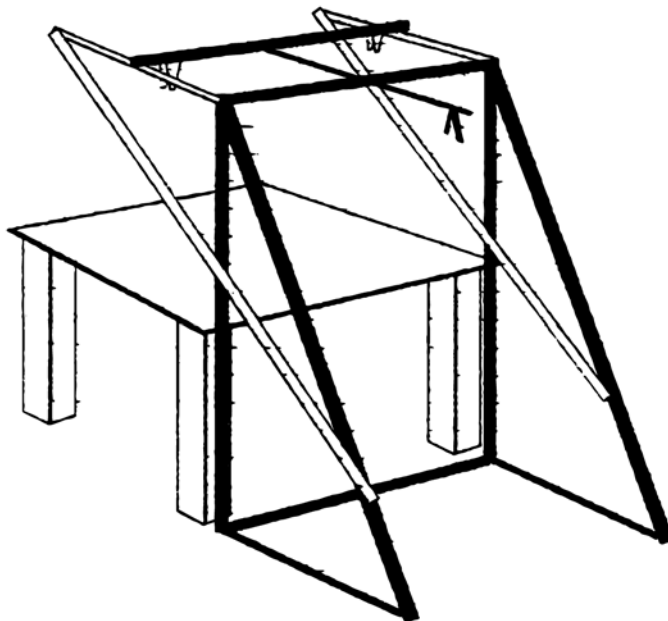

FIG. X1.1 Grip With Auto-Release

X1.1 The idea behind the holding device shown in Fig. X1.1 is to permit both uniformity and greater personnel safety. The specimen is held by the grips on the sliding bar and placed over the appropriate burning tray by pushing forward. This simulates reaching over the stove-top. When the bar hits the end it

automatically releases the specimen to drop down.

X1.2 To further eliminate variability in placement time, the sliding action could even be accomplished by reciprocating mechanism instead of laboratory personnel.

ASTM International takes no position respecting the validity of any patent rights asserted in connection with any item mentioned in this standard. Users of this standard are expressly advised that determination of the validity of any such patent rights, and the risk of infringement of such rights, are entirely their own responsibility.

This standard is subject to revision at any time by the responsible technical committee and must be reviewed every five years and if not revised, either reapproved or withdrawn. Your comments are invited either for revision of this standard or for additional standards and should be addressed to ASTM International Headquarters. Your comments will receive careful consideration at a meeting of the responsible technical committee, which you may attend. If you feel that your comments have not received a fair hearing you should make your views known to the ASTM Committee on Standards, at the address shown below.

This standard is copyrighted by ASTM International, 100 Barr Harbor Drive, PO Box C700, West Conshohocken, PA 19428-2959, United States. Individual reprints (single or multiple copies) of this standard may be obtained by contacting ASTM at the above address or at 610-832-9585 (phone), 610-832-9555 (fax), or service@astm.org (e-mail); or through the ASTM website (www.astm.org). Permission rights to photocopy the standard may also be secured from the Copyright Clearance Center, 222 Rosewood Drive, Danvers, MA 01923, Tel: (978) 646-2600; http://www.copyright.com/