



Standard Specification for Multilayer Pipe Type 2, Compression Fittings, and Compression Joints for Hot and Cold Drinking-Water Systems¹

This standard is issued under the fixed designation F1986; the number immediately following the designation indicates the year of original adoption or, in the case of revision, the year of last revision. A number in parentheses indicates the year of last reapproval. A superscript epsilon (ϵ) indicates an editorial change since the last revision or reapproval.

1. Scope

1.1 This specification covers requirements for multilayer pipe type 2 and compression fittings for hot and cold drinking-water systems, with a maximum pressure rating of 1000 kPa (145 psi) at 82°C (180°F).

NOTE 1—*Multilayer Pipe Type 2*—Construction-based pressure rated pipe comprising more than one layer in which at least 60 % of the wall thickness is polymeric material.

1.2 Multilayer pipe type 2 is produced using a butt-welded aluminum pipe as a core, with an extruded inside layer of crosslinked polyethylene (PEX). An adhesive layer is used to bond the inside layer to the wall of the aluminum pipe. An outer layer of polyethylene (PE) and an adhesive layer are extruded to the outer wall of the aluminum pipe.

1.3 Multilayer pipe type 2 is produced in configurations 1 and 2, as referenced in Fig. 1.

1.4 This specification includes compression fittings, which are referenced in Fig. 2.

1.5 Specifications for thread or solder adapters for use with pipe and fittings meeting the requirements of this specification are given in Annex A1 and Annex A2.

1.6 The following precautionary caveat pertains only to the test method portion of this specification: *This standard does not purport to address all of the safety concerns, if any, associated with its use. It is the responsibility of the user of this standard to establish appropriate safety and health practices and determine the applicability of regulatory limitations prior to use.*

1.7 The values stated in either SI units or inch-pound units are to be regarded separately as standard. The values stated in each system may not be exact equivalents; therefore, each

system shall be used independently of the other. Combining values from the two systems may result in non-conformance with the standard.

2. Referenced Documents

2.1 ASTM Standards:²

- B283 Specification for Copper and Copper-Alloy Die Forgings (Hot-Pressed)
- B455 Specification for Copper-Zinc-Lead Alloy (Leaded-Brass) Extruded Shapes
- B547/B547M Specification for Aluminum and Aluminum-Alloy Formed and Arc-Welded Round Tube
- B584 Specification for Copper Alloy Sand Castings for General Applications
- D618 Practice for Conditioning Plastics for Testing
- D1505 Test Method for Density of Plastics by the Density-Gradient Technique
- D1598 Test Method for Time-to-Failure of Plastic Pipe Under Constant Internal Pressure
- D1600 Terminology for Abbreviated Terms Relating to Plastics
- D1898 Practice for Sampling of Plastics (Withdrawn 1998)³
- D2122 Test Method for Determining Dimensions of Thermoplastic Pipe and Fittings
- D2765 Test Methods for Determination of Gel Content and Swell Ratio of Crosslinked Ethylene Plastics
- D3222 Specification for Unmodified Poly(Vinylidene Fluoride) (PVDF) Molding Extrusion and Coating Materials
- D3418 Test Method for Transition Temperatures and Enthalpies of Fusion and Crystallization of Polymers by Differential Scanning Calorimetry
- D3350 Specification for Polyethylene Plastics Pipe and Fittings Materials
- D5033 Guide for Development of ASTM Standards Relating

¹ This test method is under the jurisdiction of ASTM Committee F17 on Plastic Piping Systems and is the direct responsibility of Subcommittee F17.11 on Composite.

Current edition approved Aug. 1, 2011. Published November 2011. Originally approved in 2000. Last previous edition approved in 2006 as F1986 – 01(2006). DOI: 10.1520/F1986-01R11.

² For referenced ASTM standards, visit the ASTM website, www.astm.org, or contact ASTM Customer Service at service@astm.org. For *Annual Book of ASTM Standards* volume information, refer to the standard's Document Summary page on the ASTM website.

³ The last approved version of this historical standard is referenced on www.astm.org.

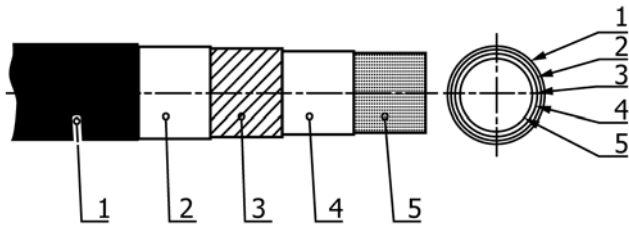

Layer:	1	2	3	4	5
Configuration 1 (drinking water)	HDPE	Adhesive Layer	Al - Alloy	Adhesive Layer	PEX ₍₁₎ crosslinked
Configuration 2 (drinking water)	MDPE	Adhesive Layer	Al - Alloy	Adhesive Layer	PEX ₍₁₎ crosslinked

PEX₍₁₎ : Material is being crosslinked during manufacturing process.

FIG. 1 Multilayer Pipe Sample for Configuration 1 and 2

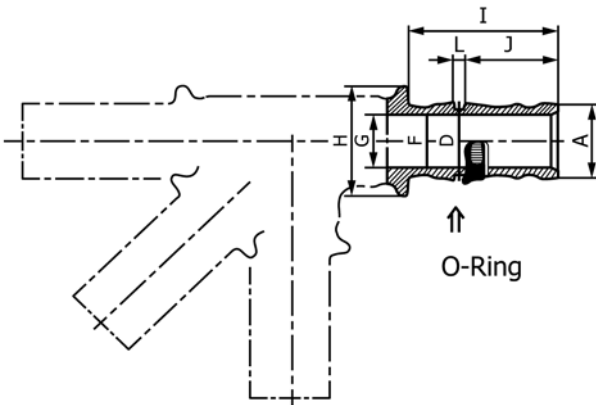

FIG. 2 Compression Fittings and O-Rings for Multilayer Pipe

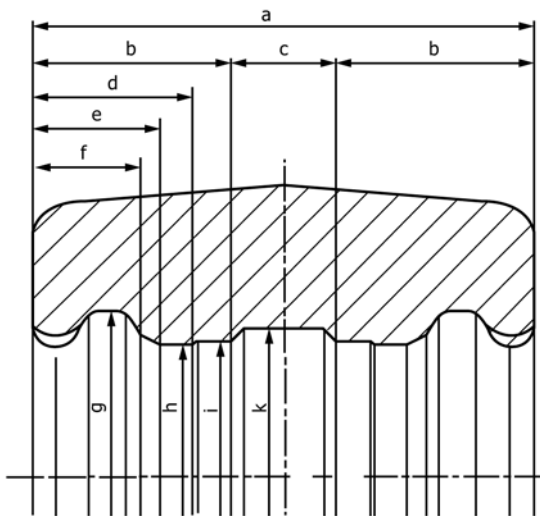

FIG. 3 Compression Tools for Multilayer Pipe

2.2 ANSI Standard:⁴

ANSI/NSF 61 Drinking Water System Components—Health Effects

2.3 ISO Standard:⁴

ISO 10508 Thermoplastics Pipe and Fittings for Hot and Cold Water Systems

2.4 ARP Standard:⁵

AS 568 A Aerospace Size Standard For O-Rings

3. Terminology

3.1 Definitions:

3.1.1 Definitions are in accordance with Terminology F412, and abbreviations are in accordance with Terminology D1600, unless otherwise specified.

3.1.2 *crosslinked polyethylene (PEX), n*—a plastic prepared by crosslinking (curing) of PE compound.

3.1.3 *multilayer pipe type 2, n*—a pipe consisting of different materials with specific functional purpose to serve as pipe.

3.1.4 *pressure ratings (PR), n*—the maximum, continuous water pressure at a specified temperature that pipe is capable of withstanding without failure.

3.2 Definitions of Terms Specific to This Standard:

3.2.1 *adhesive*—a low-molecular-weight PE that functions as an adhesive layer and bonds the PEX to aluminum pipe.

3.2.2 *compression fittings for multilayer pipe, n*—a fitting specially developed for multilayer pipe in which the aluminum core is used as compression sleeve to develop sufficient mechanical strength for the connection (see Fig. 2).

3.2.3 *multilayer pipe, n*—abbreviation used in this specification for multilayer pipe type 2.

3.2.4 *lot, n*—a lot shall consist of all pipe of the same size produced from one extrusion line during one designated period.

4. Classification

4.1 Multilayer pipe and compression fittings produced under this specification shall be suitable for hot and cold drinking water at specified pressure ratings and temperatures.

5. Materials and Manufacture

5.1 Specification for Material and Manufacture of Multilayer Pipe Configuration 1 and 2:

5.1.1 *Polyethylene (PE)*—PE shall meet the requirement provided in Specification D3350 and shall equal or exceed a minimum cell classification of 234233 B or 345442 B. Color and form of the material shall be in accordance with the agreement between purchaser and supplier under Specification D3350.

to Recycling and Use of Recycled Plastics (Withdrawn 2007)³

F412 Terminology Relating to Plastic Piping Systems

F477 Specification for Elastomeric Seals (Gaskets) for Joining Plastic Pipe

⁴ Available from American National Standards Institute (ANSI), 25 W. 43rd St., 4th Floor, New York, NY 10036, <http://www.ansi.org>.

⁵ Available from Society of Automotive Engineers (SAE), 400 Commonwealth Dr., Warrendale, PA 15096-0001, <http://www.sae.org>.

5.1.2 *Crosslinked Polyethylene (PEX)*—PEX shall meet the minimum gel content of 65 % when evaluated in accordance with Test Method **D2765**. The PEX raw material shall equal or exceed a minimum cell classification 344543 A in accordance with the Specification **D3350**. The form of the material shall be in accordance with the agreement between purchaser and supplier.

5.1.3 *Adhesive Polymers*—Adhesive polymers shall be modified low-molecular-weight PE with a minimum density of 0.915 g/cm³ and different levels of comonomer for adhesion to aluminum and other substrates. The melting point shall not be less than 120°C (248°F). Density is determined under Test Method **D1505** and melting point under Test Method **D3418**.

5.1.4 *Aluminum Pipe: Mechanical Properties*—Minimum tensile strength shall be 80 Mpa (11600 psi), minimum elongation shall be 22 % A5, in accordance with Specification **B547/B547M**.

5.1.5 *Reusable Material*—Reusable material as defined in Guide **D5033** issued from the multilayer-pipe manufacturer shall be used only for the outside coating of the multilayer pipe.

5.2 *Specification for Material and Manufacture of Compression Fittings for Multilayer Pipe:*

5.2.1 Compression fittings made from cast bronze shall meet the requirements of Specification **B584** UNS Copper Alloy No. C83600.

5.2.2 Compression fittings made from brass shall meet the requirements of Specification **B455**, UNS Copper Alloy No. C38500, or Specification **B283**, UNS Copper Alloy No. C37700.

5.2.3 Compression fittings made from plastic shall be injection molded from virgin material and meet the requirements of Specification **D3222**, Type II.

5.3 *Material Specification for O-Rings*—The O-ring material shall be EPDM, with a hardness of 70 IRHD, in accordance with Specification **F477**. O-ring dimensions shall be in accordance with AS 568 A.

6. Requirements

6.1 *Multilayer Pipe Dimensions :*

6.1.1 *Outside Diameter*—The outside diameter shall meet the requirement of **Table 1** when measured in accordance with Test Method **D2122**.

6.1.2 *Wall Thickness*—The wall thickness of multilayer pipe shall meet the requirement of **Table 1** when measured in accordance with Test Method **D2122**. The wall thickness and the outside diameter of the aluminum pipe shall be determined prior to the next manufacturing steps.

6.1.3 *Average Thickness of Inner and Outer Layers*—The average thickness of the inner and outer layers of the multilayer pipe will be calculated as follows:

6.1.3.1 *Average Thickness of the Outer Layer*—The average outside diameter of the multilayer pipe minus the average outside diameter of the aluminum pipe multiplied by 0.5.

6.1.3.2 *Average Thickness of the Inner Layer*—The average wall thickness of the multilayer pipe minus the average wall thickness of the aluminum pipe minus the average wall thickness of the outer layer.

6.1.4 *Length*—The pipe shall be supplied in coils or in straight lengths in accordance with the agreement between purchaser and seller. The tolerance shall be +100 mm for coiled lengths and +10 mm for straight lengths.

6.2 *Compression-Fitting Dimensions*—Compression fittings shall meet the requirements of **Table 2** when measured in accordance with Test Method **D2122**.

TABLE 1 Multilayer Pipe Dimensions

Configuration 1								
Outside Diameter	Inside Diameter	Wall Thickness	Thickness of Inside PEX Layer	Thickness of Inside Adhesive Layer	Aluminum Thickness	Thickness of Outside Adhesive Layer	Thickness of Outside HDPE Layer	Out-of-Roundness Minimum Inside Diameter
mm (in.)	mm (in.)	mm (in.)	mm (in.)	mm (in.)	mm (in.)	mm (in.)	mm (in.)	mm (in.)
16 ± 0.2 (0.630 ± 0.008)	11.5 ± 0.2 (0.453 ± 0.008)	2.25 +0.2 -0.1 (0.089 +0.008 -0.004)	1.00 ± 0.15 (0.039 ± 0.006)	0.15 (0.006)	0.50 +0.06 -0.02 (0.020 +0.002 -0.001)	0.15 (0.006)	0.45 ± 0.15 (0.018 ± 0.006)	10.8 (0.425)
20 ± 0.2 (0.787 ± 0.008)	15 ± 0.2 (0.591 ± 0.008)	2.50 +0.2 -0.1 (0.098 +0.008 -0.004)	1.10 ± 0.15 (0.043 ± 0.006)	0.15 (0.006)	0.60 +0.06 -0.02 (0.024 +0.002 -0.001)	0.15 (0.006)	0.50 ± 0.15 (0.020 ± 0.006)	14.3 (0.563)
26 ± 0.2 (1.024 ± 0.008)	20 ± 0.2 (0.787 ± 0.008)	3.00 +0.25 -0.1 (0.118 +0.010 -0.004)	1.25 ± 0.15 (0.049 ± 0.006)	0.15 (0.006)	0.70 +0.06 -0.02 (0.028 +0.002 -0.001)	0.15 (0.006)	0.75 ± 0.15 (0.030 ± 0.006)	19.3 (0.760)
32 ± 0.2 (1.260 ± 0.008)	26 ± 0.2 (1.024 ± 0.008)	3.00 +0.25 -0.1 (0.118 +0.010 -0.004)	1.25 ± 0.15 (0.049 ± 0.006)	0.15 (0.006)	0.80 +0.06 -0.02 (0.031 +0.002 -0.001)	0.15 (0.006)	0.65 ± 0.15 (0.026 ± 0.006)	25.3 (0.996)
40 ± 0.2 (1.575 ± 0.008)	33 ± 0.2 (1.299 ± 0.008)	3.50 +0.3 -0.1 (0.138 +0.012 -0.004)	1.45 ± 0.15 (0.057 ± 0.006)	0.15 (0.006)	1.00 +0.08 -0.03 (0.039 +0.003 -0.001)	0.15 (0.006)	0.75 ± 0.15 (0.030 ± 0.006)	32.3 (1.272)
50 ± 0.3 (1.969 ± 0.012)	42 +0.3 -0.2 (1.654 +0.012 -0.008)	4.00 +0.3 -0.1 (0.157 +0.012 -0.004)	1.80 ± 0.15 (0.071 ± 0.006)	0.15 (0.006)	1.00 +0.08 -0.03 (0.039 +0.003 -0.001)	0.15 (0.006)	0.90 ± 0.15 (0.035 ± 0.006)	41.3 (1.626)
63 ± 0.3 (2.480 ± 0.012)	54 +0.3 -0.2 (2.126 +0.012 -0.008)	4.50 +0.3 -0.1 (0.177 +0.012 -0.004)	2.30 ± 0.15 (0.091 ± 0.006)	0.15 (0.006)	1.00 +0.08 -0.03 (0.039 +0.003 -0.001)	0.15 (0.006)	0.90 ± 0.15 (0.035 ± 0.006)	53.3 (2.098)
Configuration 2								
16 ± 0.2 (0.630 ± 0.008)	11.5 ± 0.2 (0.453 ± 0.008)	2.25 +0.2 -0.1 (0.089 +0.008 -0.004)	0.60 +0.15 -0.1 (0.024 +0.006 -0.004)	0.15 (0.006)	0.40 +0.01 -0.03 (0.016 +0.000 -0.001)	0.15 (0.006)	0.95 +0.2 -0.1 (0.037 +0.008 -0.004)	10.8 (0.425)
20 ± 0.2 (0.787 ± 0.008)	15 ± 0.2 (0.591 ± 0.008)	2.50 +0.2 -0.1 (0.098 +0.008 -0.004)	0.70 +0.2 -0.1 (0.028 +0.008 -0.004)	0.15 (0.006)	0.47 +0.01 -0.03 (0.019 +0.000 -0.001)	0.15 (0.006)	1.03 +0.2 -0.1 (0.041 +0.008 -0.004)	14.3 (0.563)

TABLE 2 Compression Fittings and O-Rings for Multilayer Pipe Dimensions

NOTE 1—Plastic fittings.

Ø Pipes mm (in.)	16 (0.630)	20 (0.787)	26 (1.024)	32 (1.260)	X	40 (1.575)	X	50 (1.969)	X	63 (2.480)
Ø A	11.3 – 0.1 (0.445 – 0.004)	14.8 – 0.1 (0.583 – 0.004)	19.8 – 0.1 (0.780 – 0.004)	25.8 – 0.1 (1.016 – 0.004)		32.8 – 0.15 (1.291 – 0.006)		41.8 – 0.15 (1.646 – 0.006)		53.8 – 0.17 (2.118 – 0.007)
Ø D – 0.1 (–0.004)	9.2 (0.362)	12.7 (0.500)	17.3 (0.681)	23.3 (0.917)		30.3 (1.193)		38.2 (1.504)		48.6 (1.913)
Ø F	10 ± 0.1 (0.394±0.004)	13.4 ± 0.1 (0.528 ± 0.004)	18 ± 0.1 (0.709 ± 0.004)	24 ± 0.1 (0.945 ± 0.004)		30.6 + 0.1 – 0.15 (1.205 + 0.004 – 0.006)		39.2 + 0.1 – 0.15 (1.543 + 0.004 – 0.006)		49.8 ± 0.17 (1.961 ± 0.007)
Ø G	7.4 – 0.3 (0.291 – 0.012)	10.7 – 0.3 (0.421 – 0.012)	15 – 0.3 (0.591 – 0.012)	20.5 – 0.5 (0.807 – 0.020)		26.6 – 0.5 (1.047 – 0.020)		33 – 0.5 (1.299 – 0.020)		41 – 0.5 (1.614 – 0.020)
Ø H – 0.2 (–0.008)	17.9 (0.705)	21.9 (0.862)	28.5 (1.122)	34.7 (1.366)		43.5 (1.713)		54 (2.126)		72 (2.835)
I	26 ± 0.2 (1.024 ± 0.008)	28.5 ± 0.2 (1.122 ± 0.008)	33 ± 0.3 (1.299 ± 0.012)	29.5 ± 0.2 (1.161 ± 0.008)	38 ± 0.2 (1.496 ± 0.008)	35 ± 0.3 (1.378 ± 0.012)	44 ± 0.3 (1.732 ± 0.012)	39 ± 0.3 (1.535 ± 0.012)	50 ± 0.3 (1.969 ± 0.012)	68 ± 0.3 (2.677 ± 0.012)
J ± 0.2 (± 0.008)	16.7 (0.657)	18 (0.709)	20.5 (0.807)	15.2 (0.598)	23.7 (0.933)	18.3 (0.720)	27.3 (1.075)	19.3 (0.760)	30.3 (1.193)	35.8 (1.409)
L ± 0.1 (± 0.004)	2 (0.079)	2 (0.079)	2.4 (0.094)	2.4 (0.094)		2.4 (0.094)		3.5 (0.138)		4.4 (0.173)
O-Ring	8.5×1.5 (0.335×0.059)	12×1.5 (0.472×0.059)	15.6×1.78 (0.614×0.070)	21.95×1.78 (0.864×0.070)		28.3×1.78 (1.114×0.070)		34.6×2.62 (1.362×0.103)		46.04×3.53 (1.813×0.139)

6.2.1 *Compression Tool*—The compression tool shall meet the requirements of **Table 3** when measured in accordance with Test Method **D2122**.

6.3 *Minimum Burst Pressure*—The minimum burst pressure for multilayer pipe and compression fittings for hot and cold water systems shall be as given in **Table 5**.

6.4 *Sustained Pressure*—The multilayer pipe and fittings shall not fail at the test pressure and temperature given in **Table 6** when tested in accordance with **8.1**.

6.5 *Thermal Cycling Test*—The multilayer pipe and fittings shall not fail when tested in accordance with **8.2**.

6.6 *Excessive Temperature-Pressure Capability*—In the event of a waterheating system malfunction, the multilayer pipe and fitting shall have adequate strength to accommodate

TABLE 4 Delamination Tool Dimensions

Pipe Nominal Size	Tooling Measurements, mm (in.)		
	A ± 0.20 (±0.008)	B ± 0.20 (±0.008)	C ± 0.20 (±0.008)
16 (5/8)	11.0 (0.433)	13.6 (0.535)	15.3 (0.602)
20 (3/4)	14.5 (0.571)	17.6 (0.693)	20.0 (0.787)
26 (1)	19.5 (0.768)	23.3 (0.917)	25.7 (1.012)
32 (1 1/4)	25.5 (1.004)	29.9 (1.177)	32.2 (1.268)
40 (1 1/2)	32.5 (1.280)	37.7 (1.484)	42.0 (1.654)
50 (2)	41.5 (1.634)	47.8 (1.882)	52.5 (2.067)
63 (2 1/2)	53.5 (2.106)	61.2 (2.409)	67.5 (2.657)

short-term conditions, 30 days at 100°C (212°F), 1200 kPa (175 psi), until repairs can be made. Tests will be made in accordance with **8.7**.

6.7 Multilayer pipe and compression fittings produced for the transportation of drinking water shall be evaluated and

TABLE 3 Compression Tools for Multilayer Pipe

Ø Pipes mm (in.)	16 (0.630)	20 (0.787)	26 (1.024)	32 (1.260)	40 (1.575)	50 (1.969)	63 (2.480)
a	27.3 (1.075)	30 (1.181)	34.4 (1.354)	39.4 (1.551)	46.3 (1.823)	52.5 (2.067)	78 (3.071)
b	10.75 (0.423)	12 (0.472)	14.35 (0.565)	16.7 (0.657)	20.15 (0.793)	22.5 (0.886)	33 (1.299)
c	5.8 (0.228)	6 (0.236)	5.7 (0.224)	6 (0.236)	6 (0.236)	7.5 (0.295)	12 (0.472)
d	8.6 (0.339)	9.5 (0.374)	10.9 (0.429)	12.3 (0.484)	14.6 (0.575)	16.4 (0.646)	26.06 (1.026)
e	6.85 (0.270)	7.2 (0.283)	8 (0.315)	8.9 (0.350)	10.35 (0.407)	11 (0.433)	15.44 (0.608)
f	5.8 (0.228)	6 (0.236)	6.4 (0.252)	7.1 (0.280)	8.15 (0.321)	8.6 (0.339)	10.47 (0.412)
g	18.2 (0.717)	22.2 (0.874)	28.8 (1.134)	35 (1.378)	43.8 (1.724)	54.5 (2.146)	72.8 (2.866)
h	14.4 (0.567)	18.3 (0.720)	23.9 (0.941)	29.9 (1.177)	37.5 (1.476)	47.3 (1.862)	58.4 (2.299)
j	14.9 (0.587)	18.9 (0.744)	24.7 (0.972)	30.7 (1.209)	38.5 (1.516)	48.5 (1.909)	60.6 (2.386)
k	16.2 (0.638)	20.2 (0.795)	26.2 (1.031)	32.2 (1.268)	40.2 (1.583)	50.2 (1.976)	63.4 (2.496)

TABLE 5 Burst Pressure Test for Multilayer Pipe and Compression Fittings

Pipe Ø in mm (in.)	Minimum Burst Pressure at 20°C (68°F)
16 (0.630)	8000 kPa (1160 psi)
20 (0.787)	7000 kPa (1015 psi)
26 (1.024)	7000 kPa (1015 psi)
32 (1.260)	6000 kPa (870 psi)
40 (1.575)	6000 kPa (870 psi)
50 (1.969)	6000 kPa (870 psi)
63 (2.480)	5000 kPa (725 psi)

TABLE 6 Hydrostatic Sustained Pressure Test for Multilayer Pipe and Compression Fittings

NOTE 1—Pipe Dimension: Ø 16 - 20 - 26 - 32 - 40 - 50 - 63 mm (0.630 - 0.787 - 1.024 - 1.260 - 1.575 - 1.969 - 2.480 in.)

Hours	Temperature	Pressure
1	20°C (68°F)	1780 kPa (260 psi)
1	82°C (180°F)	1550 kPa (225 psi)
1000	20°C (68°F)	1700 kPa (245 psi)
1000	82°C (180°F)	1480 kPa (215 psi)

certified as safe for this purpose by a testing agency acceptable to the local health authority. The evaluation shall be in accordance with the requirements for chemical extraction, which are no less restrictive than those included in ANSI/NSF 61. The seal or mark of the laboratory making the evaluation should be marked on the tubing.

7. Workmanship, Finish, and Appearance

7.1 *Workmanship for Multilayer Pipe*—Multilayer pipe must have a smooth inner and outer surface, free of irregularities, such as cracks, bubbles, pin holes, or other

imperfections. There shall be no evidence of delamination during testing or assembling of multilayer pipe and the selected fittings.

7.2 *Workmanship for Compression Fittings*—Compression fittings for multilayer pipe shall be suitable for the intended application and free of defects. The selected fittings shall be smooth and free of any sharp-edged grooves, which could damage the pipe.

8. Test Methods

8.1 *Sustained Hydrostatic-Pressure Tests*—Multilayer pipe and compression fittings shall be tested in accordance with Test Method D1598. Tests shall be performed at 1 h and 1000 h in accordance with Table 6. No failure shall occur for the duration of the tests.

8.2 *Thermal Cycling Test*—The multilayer pipe and fittings shall be tested in accordance with ISO 10508 (see Fig. 4). There shall be no leakage from pipes, fittings, or joints after completion of the following: 5000 cycles, each with a duration of 30 ± 2 min at a constant internal pressure of 1000 kPa ± 50 kPa (145 ± 7.25 psi). Each cycle shall comprise 15 min of cold water at 20 ± 2°C (68 ± 3.6°F) and 15 min of hot water at 90 ± 2°C (194 ± 3.6°F).

8.3 *Water Hammer Test*—Multilayer pipe and fittings shall not fail when subjected to 10 000 cycles. Tests will be performed at room temperature, pressure cycles alternating between 100 ± 50 kPa (14.50 ± 7.25 psi) and 1500 ± 50 kPa (220 ± 7.25 psi) at a rate of 30 ± 5 per minute. Test in accordance with ISO 10508 (see Fig. 5).

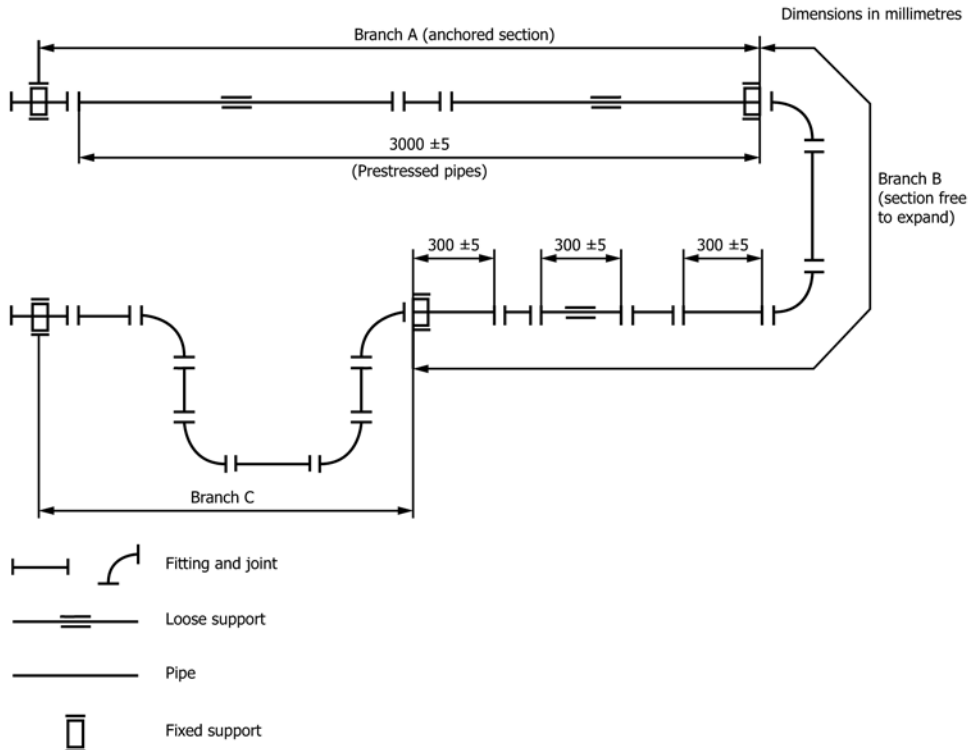

FIG. 4 Thermal Cycling Test

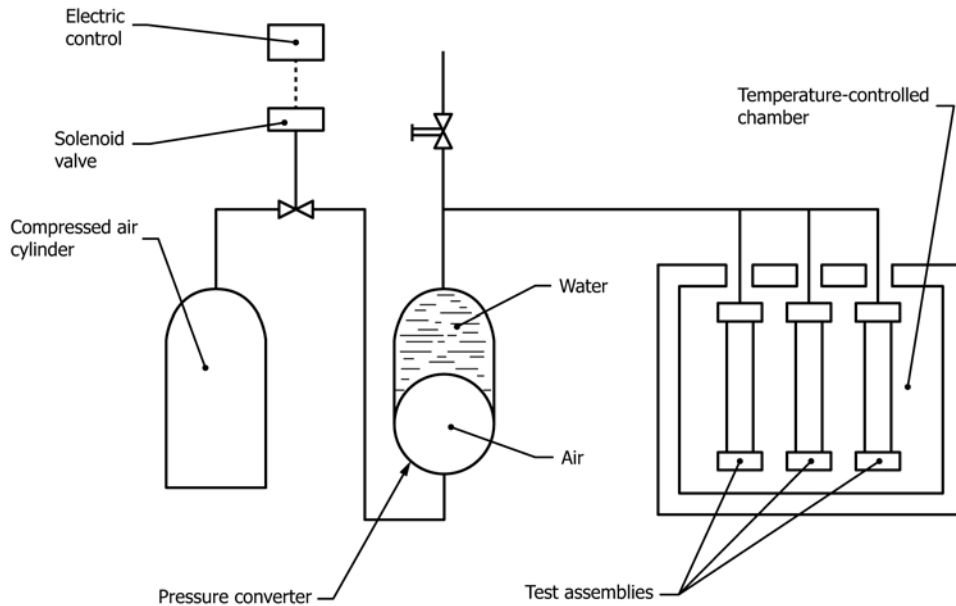

FIG. 5 Water Hammer Test

8.4 *Delamination*—Multilayer pipe shall not delaminate when tested with the adapter tool in Table 4, as described in Fig. 6. The depth to which the adapter tool is to be inserted shall be marked. No delamination of bond shall occur.

8.5 *Fusion Line Test*—The adapter tool has to be inserted into the multilayer pipe to the indicated depth (see Fig. 6). No visible damage shall occur on the fusion line or at any place of the aluminum section.

8.6 *Gel Content*—Determine the gel content of PEX, following Test Method D2765, Test Method A. The Gel content shall be equal or higher than 65 %.

8.7 *Excessive Temperature-Pressure Capability*—Test six assemblies of multilayer pipe and fittings selected at random in accordance with Test Method D1598, except the test temperature shall be $100^{\circ}\text{C} \pm 2^{\circ}\text{C}$ ($212 \pm 3.6^{\circ}\text{F}$), the test pressure shall be 1200 kPa (175 psi), the external test environment shall be air, and the specimens shall be filled with water at a temperature of at least 50°C (122°F). Leakage or separation at

any joint tested at less than 30 days (720 h) at the test pressure shall constitute failure.

9. Quality Control

9.1 Quality-control tests are valid for the whole range of diameters, but only specified test methods are accepted. A quality program shall include tests described in Section 8, test methods 8.1, 8.4, 8.5, and 8.6.

10. Sampling and Conditioning

10.1 *Sampling*—Specimens for each test shall be taken from pipe selected at random from each lot and the random sampling plan of Practice D1898. To check the gel content: A shaving of 2 ± 0.02 mm (0.079 ± 0.001 in.) will be removed from the inner surface, preferably with a lathe.

10.2 *Conditioning*—Each specimen shall be conditioned at room temperature and 50 ± 5 % relative humidity of the manufacturer’s facility for not less than 1 h, or until the temperature of the specimen is at room temperature.

10.3 *Frequency and Number of Tests for Quality Control*—The frequency and number of tests shall be under the manufacturer’s established quality-control program.

10.4 Referee Testing:

10.4.1 *Sampling*—Specimens shall be collected as per 10.1, and the number of specimens shall be prepared to obtain test results as required for those properties tested. Specimens shall be prepared under the appropriate ASTM test method, unless otherwise stated.

10.4.2 *Conditioning for Referee Testing*—Specimens shall be conditioned at $23 \pm 2^{\circ}\text{C}$ ($73 \pm 3.6^{\circ}\text{F}$) and 50 ± 5 % relative humidity for not less than 40 h before testing under Practice D618, Procedure A.

10.5 *Referee-Test Conditions*—Tests at room temperature shall be conducted at $23 \pm 2^{\circ}\text{C}$ ($73 \pm 3.6^{\circ}\text{F}$) and 50 ± 5 % relative humidity.

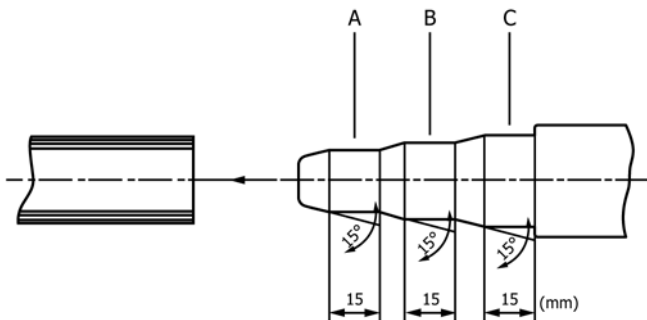

- A = inside pipe diameter guide
- B = diameter increase for bond strength test
- C = diameter increase for fusion line inspection test

FIG. 6 Delamination and Fusion Line Test

10.6 *Test Methods*—Only the test methods specified herein shall be used.

11. Rejection and Rehearing

11.1 *Rejection*—If the results of any test(s) do not meet the requirements of this specification, all tests shall be repeated. In retesting, the product requirements of this specification shall be met. If failure occurs on retest of a lot, the lot fails this specification.

11.2 *Certification*—Certification indicating compliance with the provisions of this specification, shall be provided in writing and signed by an authorized agent of the manufacturer.

12. Product Marking

12.1 *Quality of Marking*—The marking shall be applied to the pipe for end-use application in such manner that it is not removable.

12.2 *Content of Marking for Multilayer Pipe*—Marking on pipe shall include the following information, spaced at intervals of not more than 2 m:

- 12.2.1 Nominal pipe size and wall thickness,
- 12.2.2 ASTM designation F1986,
- 12.2.3 Manufacturer's name or trademark,
- 12.2.4 The Material Designation:
 - 12.2.4.1 Configuration 1 *PEX/AL/HDPE*, or

12.2.4.2 Configuration 2 *PE/AL/MDPE*,

12.2.5 Production code and type of configuration, and

12.2.6 Seal or mark of the laboratory making the evaluation for drinking water (spaced at intervals specified by the laboratory).

12.3 *Content of Marking for Compression Fittings*—Marking on the compression fittings for multilayer pipe shall include:

12.3.1 Nominal size,

12.3.2 Manufacturer's name or trademark, and

12.3.3 ASTM designation.

12.3.4 Information that cannot be placed on the fitting shall be placed on the packaging.

13. Quality Assurance

13.1 When the product is marked with the designation F1986, the manufacturer affirms that the product was manufactured, inspected, sampled, and tested in accordance with this specification and has been found to meet the requirements of this specification.

14. Keywords

14.1 butt-welded aluminum pipe; compression fittings; hot and cold drinking-water; multilayer pipe; pipe; pressure; snap-ring; solder adapter; threaded adapter

ANNEXES

(Mandatory Information)

A1. THREADED OR SOLDER ADAPTERS

A1.1 Threaded or solder adapters are designed to connect the compression fittings and compression joints described in this standard to threaded or soldered fittings.

A1.1.1 Threaded or solder adapters are referenced in [Table A1.1](#) and [Table A1.2](#), respectively. The snap-ring, a part of threaded or solder adapters to make the assembly between fittings and threaded or solder adapters is referenced in [Table A1.3](#). Fitting, threaded adapter, and snap-ring connection are shown in [Fig. A1.1](#).

A1.1.2 Threaded or solder adapters shall be made from brass or any other material found to be suitable for hot and cold drinking water application and use. The snap-ring shall be injection molded from PVDF material.

A1.2 Threaded adapters dimensions will be in accordance with [Table A1.1](#), solder adapters dimensions in accordance with [Table A1.2](#), and snap-ring in accordance with [Table A1.3](#). The thread shall conform to ASME B1.20.1.

TABLE A1.1 Adapter, with Male/Female Thread, for Compression Fitting for Multilayer Pipe

∞	Diameter		Ø A	B1	B2	Ø c	Ø d	Ø e	Ø f	g	h	i	k
	mm (in.)	MEPLA											
32 (1)	1 in.	NPT	42.1 ^{+0.15} ₀	45.5 ^{+0.3} _{-0.3}	66.5 ^{+0.5} _{-0.5}	34.8 ^{+0.1} ₀	25.8 ^{+0.04} _{-0.04}	40.3 ^{+0.05} _{-0.05}	33.8 ^{+0.3} ₀	14.9 ^{+0.2} ₀	11.3 ^{+0.1} ₀	16.8 ⁰ _{-2.3}	16.8 ^{+2.3} ₀
			(1.657 ^{+0.009} ₀)	(1.791 ^{+0.012} _{-0.012})	(2.618 ^{+0.020} _{-0.020})	(1.370 ^{+0.004} ₀)	(1.016 ^{+0.002} _{-0.002})	(1.587 ^{+0.002} _{-0.002})	(1.331 ^{+0.012} ₀)	(0.587 ^{+0.009} ₀)	(0.661 ⁰ _{-0.09})	(0.661 ^{+0.091} ₀)	
40 (1 1/4)	1 1/4 in.	NPT	52.7 ^{+0.08} _{-0.08}	53 ^{+0.3} _{-0.3}	77 ^{+0.5} _{-0.5}	43.7 ^{+0.05} _{-0.05}	32.8 ^{+0.05} _{-0.05}	50.1 ^{+0.05} _{-0.05}	42.5 ^{+0.3} ₀	17.6 ^{+0.2} ₀	13.5 ^{+0.1} ₀	19.1 ⁰ _{-2.3}	19.1 ^{+2.3} ₀
			(2.075 ^{+0.003} _{-0.003})	(2.087 ^{+0.012} _{-0.012})	(3.031 ^{+0.020} _{-0.020})	(1.720 ^{+0.002} _{-0.002})	(1.291 ^{+0.002} _{-0.002})	(1.972 ^{+0.002} _{-0.002})	(1.673 ^{+0.012} _{-0.006})	(0.698 ^{+0.009} ₀)	(0.531 ^{+0.004} ₀)	(0.752 ⁰ _{-0.091})	(0.752 ^{+0.091} ₀)
50 (1 1/2)	1 1/2 in.	NPT	64.6 ^{+0.1} _{-0.1}	82 ^{+0.3} _{-0.3}	82.5 ^{+0.5} _{-0.5}	54.2 ^{+0.05} _{-0.05}	41.8 ^{+0.08} ₀	61.6 ^{+0.05} _{-0.05}	53 ^{+0.3} ₀	19.7 ^{+0.2} ₀	15.1 ^{+0.1} ₀	19.1 ⁰ _{-2.3}	19.1 ^{+2.3} ₀
			(2.543 ^{+0.004} _{-0.004})	(3.228 ^{+0.012} _{-0.012})	(3.248 ^{+0.020} _{-0.020})	(2.134 ^{+0.002} _{-0.002})	(1.646 ^{+0.003} ₀)	(2.425 ^{+0.002} _{-0.002})	(2.087 ^{+0.012} ₀)	(0.776 ^{+0.008} ₀)	(0.594 ^{+0.004} ₀)	(0.752 ⁰ _{-0.091})	(0.752 ^{+0.091} ₀)
63 (2)	2 in.	NPT	84.8 ^{+0.1} _{-0.1}	108 ^{+0.5} _{-0.5}	107 ^{+0.5} _{-0.5}	72.2 ^{+0.1} _{-0.05}	53.8 ^{+0.1} ₀	81.4 ^{+0.05} _{-0.05}	70.2 ^{+0.3} _{-0.05}	24.7 ^{+0.2} ₀	19.2 ^{+0.1} ₀	23.4 ⁰ _{-3.5}	23.4 ^{+3.5} ₀
			(3.34 ^{+0.004} _{-0.004})	(4.252 ^{+0.020} _{-0.020})	(4.213 ^{+0.020} _{-0.020})	(2.843 ^{+0.004} _{-0.004})	(2.118 ^{+0.004} ₀)	(3.205 ^{+0.002} _{-0.002})	(2.764 ^{+0.012} _{-0.002})	(0.972 ^{+0.009} ₀)	(0.756 ^{+0.004} ₀)	(0.921 ⁰ ₀)	(0.921 ^{+0.198} ₀)

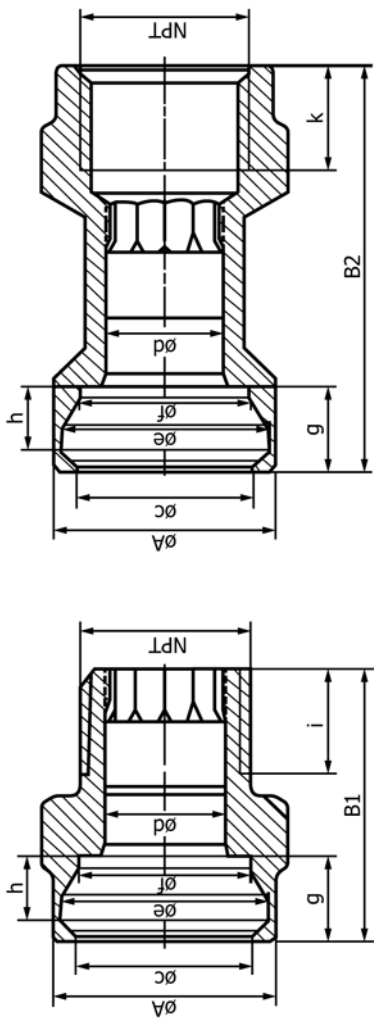
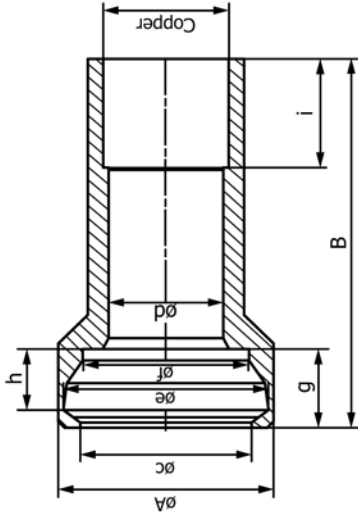

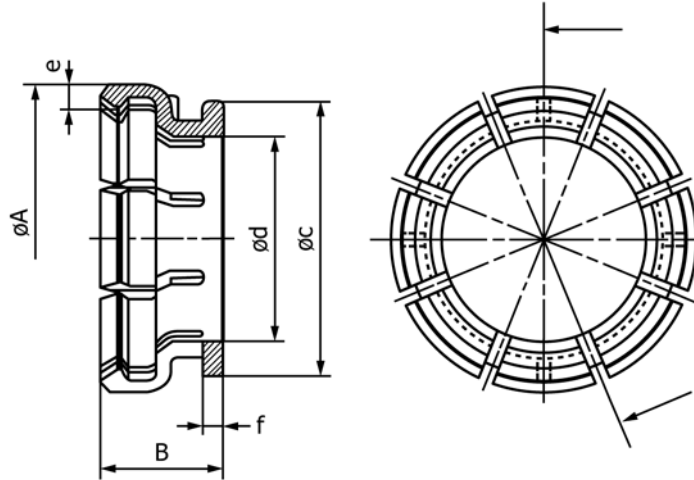

TABLE A1.2 Solder Adapter, to Copper, for Compression Fitting for Multilayer Pipe



Diameter mm (in.) MEPLA	Ø A	B	Ø c	Ø d	Ø e	Ø f	g	h	Ø F	G Min.	Internal End	
											in.	Copper
16 (1/2)	23.2 ^{+0.10} ₀ (0.913 ^{+0.004} ₀)	45 ^{+0.5} _{-0.5} (1.772 ^{+0.020} _{-0.020})	18 ^{+0.05} _{-0.05} (0.709 ^{+0.002} _{-0.002})	11.3 ^{+0.04} _{-0.04} (0.445 ^{+0.002} _{-0.002})	21.4 ^{+0.04} _{-0.04} (0.843 ^{+0.002} _{-0.002})	17.3 ^{+0.2} ₀ (0.681 ^{+0.008} ₀)	9.2 ^{+0.2} ₀ (0.362 ^{+0.008} ₀)	6.75 ^{+0.1} ₀ (0.266 ^{+0.004} ₀)	16 ^{+0.03} _{-0.07} (0.630 ^{+0.001} _{-0.008})	12.7 (0.500)		
20 (5/8)	27.6 ^{+0.10} ₀ (1.087 ^{+0.004} ₀)	49 ^{+0.5} _{-0.5} (1.929 ^{+0.020} _{-0.020})	22 ^{+0.05} _{-0.05} (0.866 ^{+0.002} _{-0.002})	14.8 ^{+0.04} _{-0.04} (0.583 ^{+0.002} _{-0.002})	25.9 ^{+0.05} _{-0.05} (1.020 ^{+0.002} _{-0.002})	21.2 ^{+0.2} ₀ (0.835 ^{+0.008} ₀)	10.8 ^{+0.2} ₀ (0.425 ^{+0.008} ₀)	8.05 ^{+0.1} ₀ (0.317 ^{+0.004} ₀)	16 ^{+0.03} _{-0.07} (0.630 ^{+0.001} _{-0.008})	12.7 (0.500)		
26 (3/4)	34.9 ^{+0.12} ₀ (1.374 ^{+0.005} ₀)	60 ^{+0.5} _{-0.5} (2.362 ^{+0.020} _{-0.020})	22 ^{+0.05} _{-0.05} (0.866 ^{+0.002} _{-0.002})	14.8 ^{+0.04} _{-0.04} (0.583 ^{+0.002} _{-0.002})	25.9 ^{+0.05} _{-0.05} (1.020 ^{+0.002} _{-0.002})	21.2 ^{+0.2} ₀ (0.835 ^{+0.008} ₀)	10.8 ^{+0.2} ₀ (0.425 ^{+0.008} ₀)	8.05 ^{+0.1} ₀ (0.317 ^{+0.004} ₀)	22.3 ^{+0.08} _{-0.02} (0.878 ^{+0.003} _{-0.001})	19.1 (0.752)		
32 (1)	42.1 ^{+0.15} ₀ (1.657 ^{+0.006} ₀)	69 ^{+0.5} _{-0.5} (2.717 ^{+0.020} _{-0.020})	34.8 ^{+0.1} ₀ (1.370 ^{+0.004} ₀)	25.8 ^{+0.04} _{-0.04} (1.016 ^{+0.002} _{-0.002})	40.3 ^{+0.05} _{-0.05} (1.587 ^{+0.002} _{-0.002})	33.8 ^{+0.3} ₀ (1.331 ^{+0.012} ₀)	14.9 ^{+0.2} ₀ (0.587 ^{+0.008} ₀)	11.3 ^{+0.1} ₀ (0.445 ^{+0.004} ₀)	28.7 ^{+0.05} _{-0.05} (1.130 ^{+0.002} _{-0.002})	23.1 (0.909)		
40 (1 1/4)	52.7 ^{+0.08} _{-0.08} (2.075 ^{+0.003} _{-0.003})	78 ^{+0.5} _{-0.5} (3.071 ^{+0.020} _{-0.020})	43.7 ^{+0.05} _{-0.05} (1.720 ^{+0.002} _{-0.002})	32.8 ^{+0.05} _{-0.05} (1.291 ^{+0.002} _{-0.002})	50.1 ^{+0.05} _{-0.05} (1.972 ^{+0.002} _{-0.002})	42.5 ^{+0.3} ₀ (1.673 ^{+0.008} ₀)	17.6 ^{+0.2} ₀ (0.693 ^{+0.008} ₀)	13.5 ^{+0.1} ₀ (0.531 ^{+0.004} ₀)	35 ^{+0.10} ₀ (1.378 ^{+0.004} ₀)	24.6 (0.969)		
50 (1 1/2)	64.6 ^{+0.1} _{-0.1} (2.543 ^{+0.004} _{-0.004})	90 ^{+0.5} _{-0.5} (3.543 ^{+0.020} _{-0.020})	54.2 ^{+0.05} _{-0.05} (2.134 ^{+0.002} _{-0.002})	41.8 ^{+0.08} ₀ (1.646 ^{+0.003} _{-0.003})	61.6 ^{+0.05} _{-0.05} (2.425 ^{+0.002} _{-0.002})	53 ^{+0.3} ₀ (2.087 ^{+0.012} ₀)	19.7 ^{+0.2} ₀ (0.776 ^{+0.008} ₀)	15.1 ^{+0.1} ₀ (0.594 ^{+0.004} ₀)	41.4 ^{+0.08} _{-0.05} (1.630 ^{+0.003} _{-0.002})	27.7 (1.091)		
63 (2)	84.8 ^{+0.1} _{-0.1} (3.34 ^{+0.004} _{-0.004})	116 ^{+0.5} _{-0.5} (4.567 ^{+0.020} _{-0.020})	72.2 ^{+0.1} _{-0.05} (2.843 ^{+0.004} _{-0.002})	53.8 ^{+0.1} ₀ (2.118 ^{+0.004} _{-0.002})	81.4 ^{+0.05} _{-0.05} (3.205 ^{+0.002} _{-0.002})	70.2 ^{+0.2} _{-0.05} (2.764 ^{+0.012} _{-0.002})	24.7 ^{+0.2} ₀ (0.972 ^{+0.008} ₀)	19.2 ^{+0.1} ₀ (0.756 ^{+0.004} ₀)	54.1 ^{+0.08} _{-0.05} (2.130 ^{+0.003} _{-0.003})	34 (1.339)		

TABLE A1.3 Snap-Ring for Thread or Solder Adapter, for Compression Fitting for Multilayer Pipe



Diameter mm (in.) MEPLA	Ø A	B	Ø C	Ø d	e	f
16 (1/2)	19.3 ^{+0.2} _{-0.2} (0.760 ^{+0.008} _{-0.008})	8.0 ^{+0.08} _{-0.08} (0.315 ^{+0.003} _{-0.003})	17.1 ^{+0.12} _{-0.12} (0.673 ^{+0.005} _{-0.005})	12.3 ^{+0.17} _{-0.17} (0.484 ^{+0.007} _{-0.007})	1.6 ^{+0.07} _{-0.07} (0.063 ^{+0.003} _{-0.003})	1.4 ^{+0.11} _{-0.11} (0.055 ^{+0.004} _{-0.004})
20 (5/8)	23.5 ^{+0.3} _{-0.3} (0.925 ^{+0.012} _{-0.012})	9.4 ^{+0.10} _{-0.10} (0.370 ^{+0.004} _{-0.004})	21 ^{+0.15} _{-0.15} (0.827 ^{+0.006} _{-0.006})	15.8 ^{+0.2} _{-0.2} (0.622 ^{+0.008} _{-0.008})	1.8 ^{+0.07} _{-0.07} (0.071 ^{+0.003} _{-0.003})	1.6 ^{+0.11} _{-0.11} (0.063 ^{+0.004} _{-0.004})
26 (3/4)	30.6 ^{+0.4} _{-0.4} (1.205 ^{+0.016} _{-0.016})	10.9 ^{+0.10} _{-0.10} (0.429 ^{+0.004} _{-0.004})	27.3 ^{+0.18} _{-0.18} (1.075 ^{+0.007} _{-0.007})	21 ^{+0.2} _{-0.2} (0.827 ^{+0.008} _{-0.008})	2.15 ^{+0.07} _{-0.07} (0.085 ^{+0.003} _{-0.003})	1.8 ^{+0.11} _{-0.11} (0.071 ^{+0.004} _{-0.004})
32 (1)	37.2 ^{+0.5} _{-0.5} (1.465 ^{+0.020} _{-0.020})	12.9 ^{+0.10} _{-0.10} (0.508 ^{+0.004} _{-0.004})	33.5 ^{+0.20} _{-0.20} (1.319 ^{+0.008} _{-0.008})	26.9 ^{+0.24} _{-0.24} (1.059 ^{+0.009} _{-0.009})	2.55 ^{+0.07} _{-0.07} (0.100 ^{+0.003} _{-0.003})	2 ^{+0.11} _{-0.11} (0.079 ^{+0.004} _{-0.004})
40 (1 1/4)	46.5 ^{+0.7} _{-0.7} (1.831 ^{+0.028} _{-0.028})	15.4 ^{+0.10} _{-0.15} (0.606 ^{+0.004} _{-0.006})	42.2 ^{+0.22} _{-0.22} (1.661 ^{+0.009} _{-0.009})	33.9 ^{+0.28} _{-0.28} (1.335 ^{+0.011} _{-0.011})	3 ^{+0.07} _{-0.07} (0.118 ^{+0.003} _{-0.003})	2.4 ^{+0.11} _{-0.11} (0.094 ^{+0.004} _{-0.004})
50 (1 1/2)	57.8 ^{+0.8} _{-0.8} (2.276 ^{+0.031} _{-0.031})	17.2 ^{+0.10} _{-0.15} (0.677 ^{+0.004} _{-0.006})	52.7 ^{+0.25} _{-0.25} (2.075 ^{+0.010} _{-0.010})	43.3 ^{+0.33} _{-0.33} (1.705 ^{+0.013} _{-0.013})	3.6 ^{+0.08} _{-0.08} (0.142 ^{+0.003} _{-0.003})	2.6 ^{+0.11} _{-0.11} (0.102 ^{+0.004} _{-0.004})
63 (2)	76.5 ^{+1.0} _{-1.0} (3.012 ^{+0.039} _{-0.039})	21.9 ^{+0.10} _{-0.15} (0.862 ^{+0.004} _{-0.006})	69.8 ^{+0.28} _{-0.28} (2.748 ^{+0.011} _{-0.011})	56.4 ^{+0.40} _{-0.40} (2.220 ^{+0.016} _{-0.016})	4.35 ^{+0.08} _{-0.08} (0.171 ^{+0.003} _{-0.003})	3.2 ^{+0.12} _{-0.12} (0.126 ^{+0.005} _{-0.005})

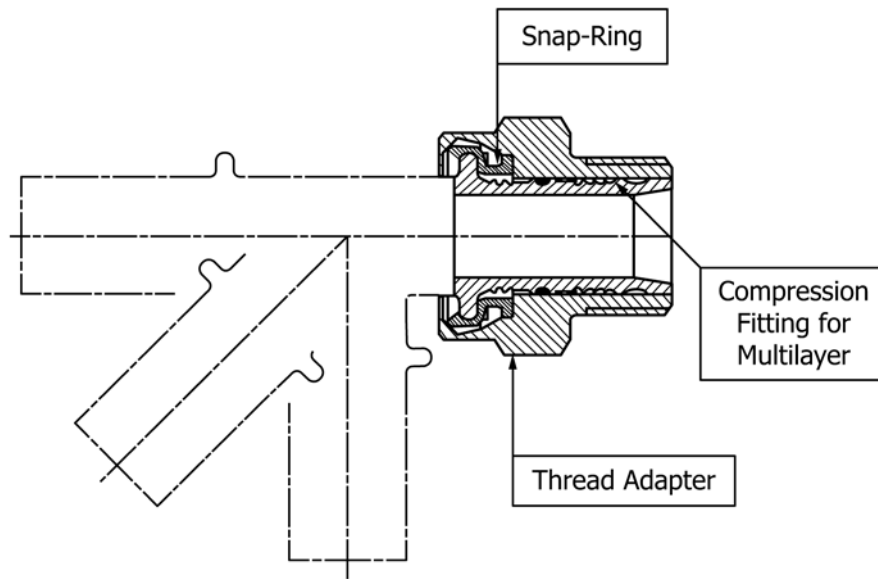

FIG. A1.1 Compression Fitting with Thread Adapter (and Snap-Ring) for Multilayer Pipe

A2. PERFORMANCE REQUIREMENT FOR THREADED OR SOLDER ADAPTERS

A2.1 *General*—Threaded or solder adapters shall be capable of meeting the short- and long-term pipe and fittings requirements listed in Section 6.

A2.2 Threaded or solder adapters produced for the transportation of drinking water shall be evaluated and certified as safe for this purpose by a testing agency acceptable to the local health authority. The evaluation shall be in accordance with the requirements for chemical extraction that are no less restrictive than those included in ANSI/NSF Standard No 61. The seal or mark of the laboratory making the evaluation should be marked on the adapter.

A2.3 *Workmanship, Finish and Appearance for Threaded or Solder Adapters*—Threaded or solder adapters shall be suitable for the intended application and free of defects. The selected threaded or solder adapters shall be smooth and free of any sharp-edge grooves, which could damage the fitting.

A2.4 *Tests Methods*—Test methods for threaded and solder adapters will be identical to those listed in Section 8.

A2.5 *Quality Assurance*—When the threaded or solder adapter packing is marked with the ASTM Designation F1986, the manufacturer affirms that the product was manufactured, inspected, sampled, and tested in accordance with this specification and has been found to meet the requirements of this specification.

A2.6 *Quality of Marking*—The marking applied on the threaded or solder adapter shall be made in such a manner that it remains legible after installation and inspection.

A2.7 *Content of Marking*—Any marking that cannot fit on threaded or solder adapters shall be applied on the packaging.

A2.7.1 Marking shall include:

- (1) Manufacturer's name or trademark,
- (2) Specification F1986, the standard designation,
- (3) Nominal size, and
- (4) Seal or mark of the laboratory making the evaluation for drinking water.

APPENDIXES

(Nonmandatory Information)

X1. CONSTRUCTION

X1.1 The multilayer pipe is made by a continuous-extrusion process with five layers of different materials. A butt-welded aluminum tube with the weld laying parallel to the pipe axis is situated between two polymeric layers. Extruded adhesive

coats allow adhesion between the components.

X1.2 The pipe section is perfectly homogeneous in the circumference, and this process allows unlimited lengths.

X2. PRESSURE RATING

X2.1 The methodology used to define long-term hydrostatic pressure is based on ISO 10508, Test Method TR 9080.

designed factor of 1.5. The pressure rating at 82°C (180°F) is 1000 kPa (145 psi).

X2.2 In accordance with ISO 10508, Test Method TR 9080, the MRP for multilayer pipe made in conformity to this specification is 1500 kPa (220 psi) at 82°C (180°F), using a

ASTM International takes no position respecting the validity of any patent rights asserted in connection with any item mentioned in this standard. Users of this standard are expressly advised that determination of the validity of any such patent rights, and the risk of infringement of such rights, are entirely their own responsibility.

This standard is subject to revision at any time by the responsible technical committee and must be reviewed every five years and if not revised, either reapproved or withdrawn. Your comments are invited either for revision of this standard or for additional standards and should be addressed to ASTM International Headquarters. Your comments will receive careful consideration at a meeting of the responsible technical committee, which you may attend. If you feel that your comments have not received a fair hearing you should make your views known to the ASTM Committee on Standards, at the address shown below.

This standard is copyrighted by ASTM International, 100 Barr Harbor Drive, PO Box C700, West Conshohocken, PA 19428-2959, United States. Individual reprints (single or multiple copies) of this standard may be obtained by contacting ASTM at the above address or at 610-832-9585 (phone), 610-832-9555 (fax), or service@astm.org (e-mail); or through the ASTM website (www.astm.org). Permission rights to photocopy the standard may also be secured from the Copyright Clearance Center, 222 Rosewood Drive, Danvers, MA 01923, Tel: (978) 646-2600; <http://www.copyright.com/>