



Standard Specification for Nonpowered Bicycle Trailers Designed for Human Passengers¹

This standard is issued under the fixed designation F1975; the number immediately following the designation indicates the year of original adoption or, in the case of revision, the year of last revision. A number in parentheses indicates the year of last reapproval. A superscript epsilon (ϵ) indicates an editorial change since the last revision or reapproval.

1. Scope

1.1 This specification covers a nonpowered trailer intended to be pulled behind a bicycle in order to transport one or two children with an accessory load of a maximum weight of 45.4 kg (100 lb). It includes test methods for confirming that this specification is satisfied.

1.2 The values stated in SI units are to be regarded as the standard. The units given in parentheses are for information only.

1.3 The following caveat pertains only to the test methods portion, Section 5, of this specification: *This standard does not purport to address all of the safety concerns, if any, associated with its use. It is the responsibility of the user of this standard to establish appropriate safety and health practices and determine the applicability of regulatory limitations prior to use.*

2. Referenced Documents

2.1 ASTM Standards:²

[B117 Practice for Operating Salt Spray \(Fog\) Apparatus](#)
[D1230 Test Method for Flammability of Apparel Textiles](#)
[D4329 Practice for Fluorescent Ultraviolet \(UV\) Lamp Apparatus Exposure of Plastics](#)
[G23 Practice for Operating Light-Exposure Apparatus \(Carbon-Arc Type\) With and Without Water for Exposure of Nonmetallic Materials \(Withdrawn 2000\)](#)³

2.2 ANSI Standard:⁴

[ANSI Z535.4, Product Safety Signs and Labels](#)

2.3 Federal Standards:⁵

[Title 16, CFR 1500.3\(b\)\(4\)\(i\) Hazardous Substance](#)
[Title 16, CFR 1500.3\(c\)\(6\)\(vi\) Flame Testing](#)
[Title 16, CFR 1500.44 Flammability](#)
[Title 16, CFR 1500.48 Sharp Points](#)
[Title 16, CFR 1500.49 Sharp Edges](#)
[Title 16, CFR 1501 Small Parts](#)
[Title 16, CFR 1303 Lead in Coatings](#)
[Title 16, CFR 1512 Requirements for Bicycles, Sections: 1512.18\(n\), Reflector Test](#)

3. Terminology

3.1 Definitions of Terms Specific to This Standard:

3.1.1 *backrest, n*—the segment of the seat that is designed to support the occupant's back. This may or may not include support for the upper body, including the head and neck.

3.1.2 *bicycle trailer (trailer), n*—a transporting device designed for towing behind a bicycle, which provides a restrained seating position to one or more occupants, with fastening arrangements for attaching the device.

3.1.3 *hard horizontal surface, n*—a surface, perpendicular to the direction of gravity, such as level ground or building floor, whose surface is either concrete, pavement, or similar rigid material whose deflection, while carrying the weight of a fully loaded trailer, does not exceed 12.7 mm (0.5 in.) from the unloaded horizontal plane at any point.

3.1.4 *normal use, n*—applications described as intended use for the product found within the manufacturer's instructional literature.

3.1.5 *normal use temperatures, n*—temperature range within which it should be anticipated that the trailer may be used to transport children. The range is from $-7 \pm 2^\circ\text{C}$ to $35 \pm 2^\circ\text{C}$ ($-19.4 \pm 4.6^\circ\text{F}$ to $95 \pm 4.6^\circ\text{F}$).

3.1.6 *occupant, n*—a child or person who is restrained in a seated position inside the trailer and whose efforts do not contribute to the overall operation and performance of the vehicle.

⁵ *Code of Federal Regulations*, available from U.S. Government Printing Office, Washington, DC 20402.

¹ This specification is under the jurisdiction of ASTM Committee F08 and is the direct responsibility of Subcommittee F08.10 on Bicycles.

Current edition approved Oct. 1, 2015. Published December 2015. Originally approved in 1999. Last previous edition approved in 2009 as F1975–09. DOI: 10.1520/F1975-15.

² For referenced ASTM standards, visit the ASTM website, www.astm.org, or contact ASTM Customer Service at service@astm.org. For *Annual Book of ASTM Standards* volume information, refer to the standard's Document Summary page on the ASTM website.

³ The last approved version of this historical standard is referenced on www.astm.org.

⁴ Available from American National Standards Institute (ANSI), 25 W. 43rd St., 4th Floor, New York, NY 10036, <http://www.ansi.org>.

3.1.7 *restrain, v*—to prevent the occupant(s) of the trailer from leaving the seated position on the seat of the trailer by means of a restraint system (designed by the manufacturer) when used in accordance with the manufacturer’s instructions.

3.1.8 *rider, n*—a person whose effort and skills contribute to the overall operation and performance of the vehicle.

3.1.9 *seated height space, n*—a dimension of space that is within the protective structure of a trailer. This space is the measured height of the occupant’s protective cavity, measured from the seat bottom and along the backrest to the top of the space allowed for occupants.

3.1.10 *test dummy, n*—a dummy that shall be of a design consistent with the use of the trailer seat and restraint system. It shall have adequate head/neck, shoulder, and arm geometry to ensure proper application of the upper body restraints. The weight of the dummy shall be 22.7 ± 1 kg (50 ± 2.2 lb). The upper legs, measured perpendicularly from the dummy’s back, shall extend a minimum of 375 mm (14.8 in.). The dummy’s back is the surface of the dummy that is in contact with the seat back when the dummy is seated. The dummy’s bottom is the surface of the dummy that is in contact with the seat bottom when the dummy is in the seated position. The weight distribution throughout the dummy shall result in a center of gravity position that is 230 ± 10 mm (9.1 ± 0.4 in.) from the dummy’s bottom and 130 ± 10 mm (5.1 ± 0.4 in.) from the dummy’s back when in the seated position.

3.1.11 *tongue, n*—a rigid structure or pole that extends from the frame of the trailer to the hitch of the trailer.

3.1.12 *useful product lifecycle, n*—the allowable range of time for continued use of the product from the date of manufacture as described within the manufacturer’s instructional literature.

4. Requirements

4.1 *General*—A bicycle trailer shall be designed and manufactured in such a way that when used in accordance with the manufacturer’s instructions, components with which an occupant may come in contact do not cause injury. Exposed surfaces shall be free from burrs, sharp edges, and points. Refer to Title 16, CFR 1500, Parts 48 and 49, and Title 16, CFR 1501. No openings with which the occupants’ hands can come in contact shall have dimensions between 6 mm (0.236 in.) and 13 mm (0.512 in.). A trailer shall be equipped with a rear reflector; side reflectors are required on wheels. Refer to Title 16, CFR 1512, Parts 16 and 18(n). The manufacturer shall warn the rider that a load added to the bicycle will alter the stability and riding characteristics of the bicycle.

4.2 *Equipment*—A trailer shall be equipped with the following equipment: seating area, footrest area, space for helmeted head, devices that protect the hands and feet from moving or movable components of the trailer or the bicycle that could cause injury, and adjustable belt(s) or other capturing devices designed to restrain the occupant when seated.

4.3 *Attachment*—The attachment process for connecting the trailer to the bicycle shall be of a simple and secure procedure. If tools are required for attachment, attaching shall be accomplished with common household tools.

4.4 *Dimensions*—The backrest shall have a minimum height of 350 mm (13.8 in.). The seated height space shall be a minimum of 550 mm (22 in.).

4.5 Materials:

4.5.1 All nonmetallic materials that compose structural components will be subjected to either (1) 100 h of accelerated weathering in accordance with Method 1 of Practice G23, or (2) 60 h of accelerated weathering in accordance with Practice D4329. The material sample will then be subjected to a tensile strength test with increasing load until failure. An identical sample of the same material, not subjected to the accelerated weathering test, will then be subjected to the same tensile strength test. The failure load of the accelerated weathering sample shall be a minimum of 60 % of the failure load of the unweathered sample.

4.5.2 All metallic materials of structural components shall be tested in accordance with the Salt Spray Test in Practice B117 for a period of 96 h. Materials shall be placed in the test environment in a condition consistent with their application on the trailer, with surface coatings and openings sealed or open as in normal use. After exposure to the salt spray, inspect for evidence of corrosion. No corrosion beyond 20 % of the primary wall thickness of the metal material is permitted. Painted portions shall comply with Title 16, CFR 1303.

4.5.3 Materials known to be a hazardous substance, as defined in Title 16, CFR 1500.3(b)(4)(i), shall not be used.

4.5.4 Materials other than fabrics shall not support flame propagation in excess of the requirements of Title 16, CFR 1500.3(c)(6)(vi) when flame tested to Title 16, CFR 1500.44. Fabrics shall achieve a Class 1 rating when tested in accordance with Test Method D1230.

5. Test Methods

5.1 *Strength Tests*—The dummy, or dummies, to be used in the following tests shall comply with the dummy specification in 3.1.10.

5.1.1 Restraint System Test:

5.1.1.1 Erect the trailer in the manufacturer’s suggested use configuration. Remove the trailer tongue. Restrain a dummy into each seating position in accordance with the manufacturer’s instruction for maximum occupancy.

5.1.1.2 Elevate the trailer, as shown in Fig. 1, from the rear, so that the orientation toward the ground is the same as the trailer’s direction of forward motion when attached to a bicycle (front-most structure of the trailer is closest to the impact surface). The impact surface is a hard material, concrete or similar. The drop height is 1.2 m (3.9 ft).

5.1.1.3 By convenient method, release the trailer to drop onto the surface.

5.1.1.4 Inspect the trailer structure. No part of the occupant’s protective structure shall deform more than 25 mm (1.0 in.), or separate. No part of the restraint system shall separate.

5.1.2 Structural Integrity in Rollover:

5.1.2.1 Erect the trailer in the manufacturer’s suggested use configuration. Remove the wheels.

5.1.2.2 Place the trailer, as defined by 5.1.2.1, onto the 45° incline test table shown in Fig. 2. Fix the trailer to the test table

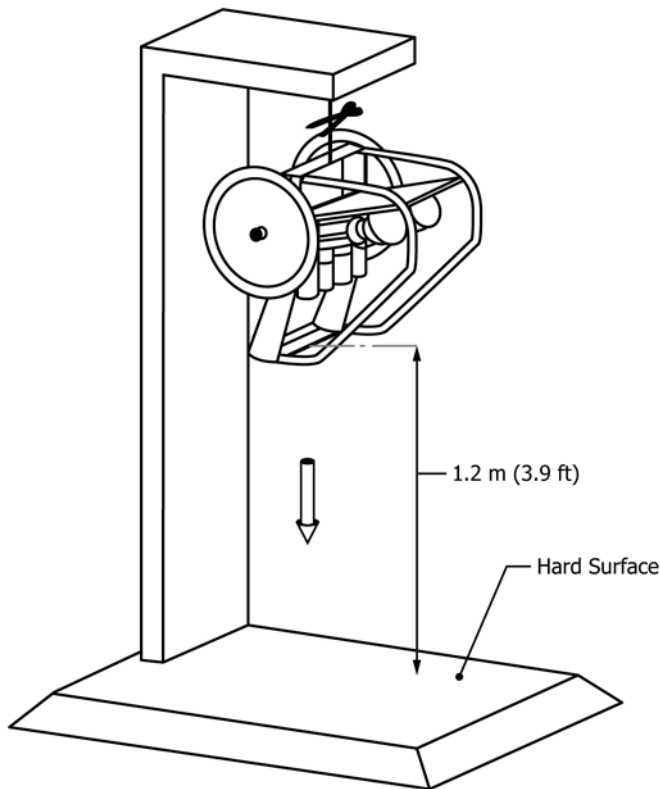

FIG. 1 Elevating the Trailer

at the wheel attachment points using dummy wheel hubs, and at the tongue attachment point of the trailer using a dummy trailer tongue.

5.1.2.3 Position the lever arm with the sled placed over the topmost point of the trailer frame, as shown. The sled has bearings permitting it to roll along the lever as a load is applied. With the weight of the lever arm and the sled resting on the trailer frame, mark the position of the sled, along the lever arm. This is the initial position mark.

5.1.2.4 Measure the load, F . This is the force applied at the contact point by the combined weight of the lever arm and sled. This force shall be less than 20 kg (44 lb).

5.1.2.5 Determine the appropriate amount of weight to hang from the end of the lever arm. Measure the distance along the lever from the pivot point to the trailer contact point, this is measure T in Fig. 2. Then measure the length, L , along the lever arm from the pivot point to the weight attachment point. Determine the size of the weight, W , from the calculation in Fig. 2.

5.1.2.6 Place the weight W at the end of the lever arm, Fig. 3, for 15 s then remove. The trailer must support that weight, statically, for 10 s of that period. Leave the lever arm and sled resting on the trailer. Mark the position of the sled along the lever arm. This is the final position mark.

5.1.2.7 The distance between the initial position mark and final position mark shall be less than 80 mm (3.1 in.).

5.2 Tipover Resistance Tests:

5.2.1 *Tilting Procedure*—Tilt the table until the uphill wheel starts to lift off the table. The tilt rate should be sufficiently

slow that the angle of the table at which the uphill tire lifts off can be easily identified.

5.2.2 *Single or Multiple-Occupant Trailer Test*—Erect the trailer in the manufacturer’s suggested use configuration and inflate the tires to the trailer manufacturer’s suggested air pressure. Restrain a dummy or dummies into the most onerous seating position (worst case as defined by the manufacturer). The minimum allowable tilt angle for the single-occupant trailer is 25°.

5.3 Coupling Security Test:

5.3.1 Erect the trailer in the manufacturer’s suggested use configuration. Inflate the tires to the trailer manufacturer’s suggested air pressure. Restrain a dummy into each seating position in accordance with the manufacturer’s instruction for maximum occupancy. By convenient method place an additional 5.7 kg (12.5 lb), per dummy, onto the trailer seat.

5.3.2 Fasten the trailer as shown in Fig. 4 to the rear bicycle frame portion of the test fixture. The test fixture must comply with the specifications found in Fig. 5. Measure the horizontal position of the hitch relative to a convenient part of the rear bike frame.

5.3.3 Fix a rail or barrier device along the path of the trailers left or right wheel to prevent side-to-side motion of the trailer during the test. (A trailers with a tongue designed to approach the bicycle on the right side will tend to move left during this test.)

5.3.4 Start the test and set the motor to run at 60 ± 2 rpm. Allow the test to run for a duration of 100 000 cycles.

5.3.5 Inspect the trailer tongue, hitch, and tongue mounting hardware. No part of the construction shall separate or incur a fracture or crack. Repeat the horizontal hitch placement measurement of 5.3.2. The difference in this measurement, before and after the test, shall not exceed 15 mm (0.6 in.).

5.4 System Fatigue Test (Axle/Frame):

5.4.1 The test equipment shall be capable of simulating the passing of the trailer over a bump. The device is a drum with the trailer positioned so the wheel or wheels sit atop the drum (Fig. 6). The placement of the wheel axle shall be between 25 and 50 mm (1.0 to 2.0 in.) rearward in the horizontal direction from the highest point on the drum. The minimum width of the flywheel shall be wide enough to permit the trailer to move side-to-side a distance of 150 mm (6 in.) in either direction. The drum shall have one cleat if testing a single-wheel trailer and two cleats if testing a two-wheel trailer. The cleat shall be no less than 38 mm (1.5 in.) high and no greater than 100 mm (3.9 in.) in the direction of motion. The leading edge shall be inclined at 45° from horizontal, and the drop at the trailing edge shall be 90° from horizontal. The single cleat shall be centered across the trailer path and occupy the minimum width of the flywheel. The two cleats shall each be a minimum of 300 mm (11.8 in.) long and centered perpendicular to the track of each trailer wheel in a manner where the first cleat strikes the wheel on one side only, and proceeds to strike the next evenly spaced cleat at no less than a distance of 1016 mm (40 in.). The horizontal speed at which the trailer’s axle approaches the cleat shall be no more than 13 km/h (8 mph) and no less than 12 km/h (7.5 mph). The speed shall be set in this range to avoid harmonic resonance of the trailer. If multiple cleats for a

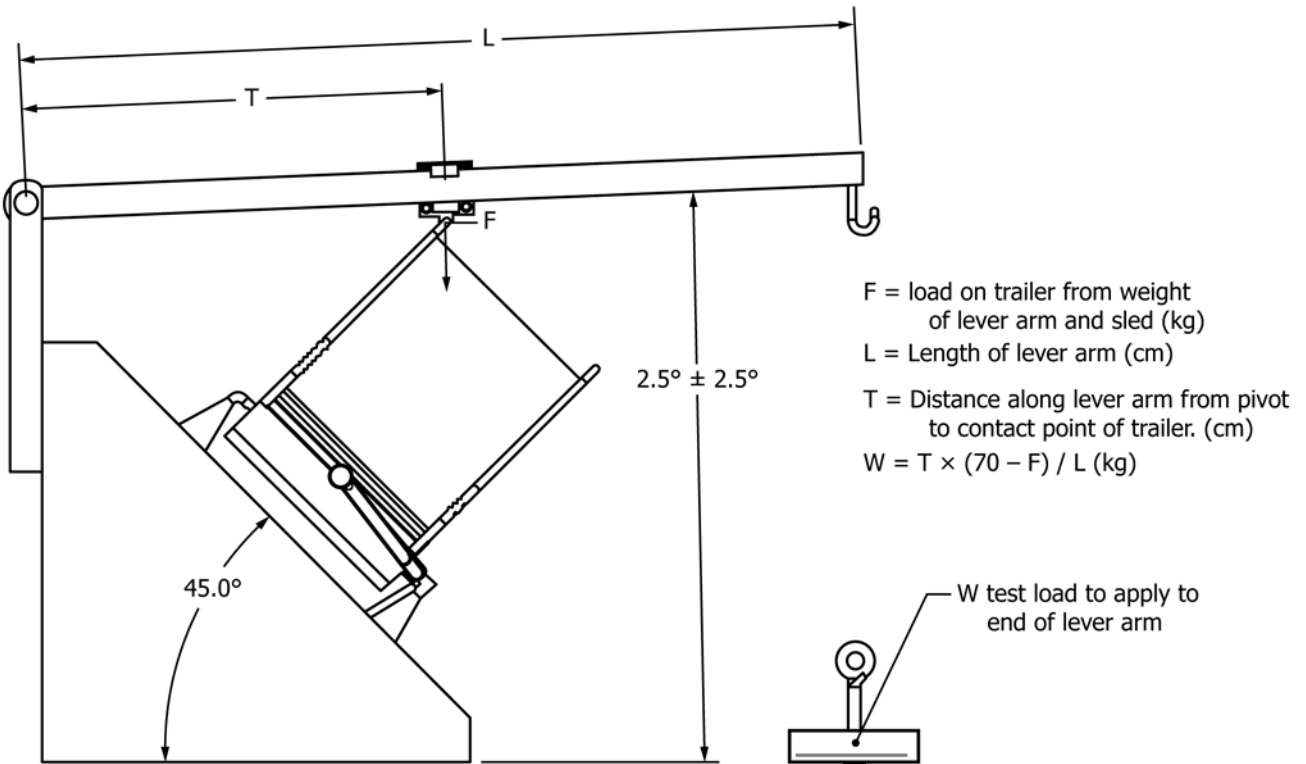

FIG. 2 Roll Test Before Load is Applied

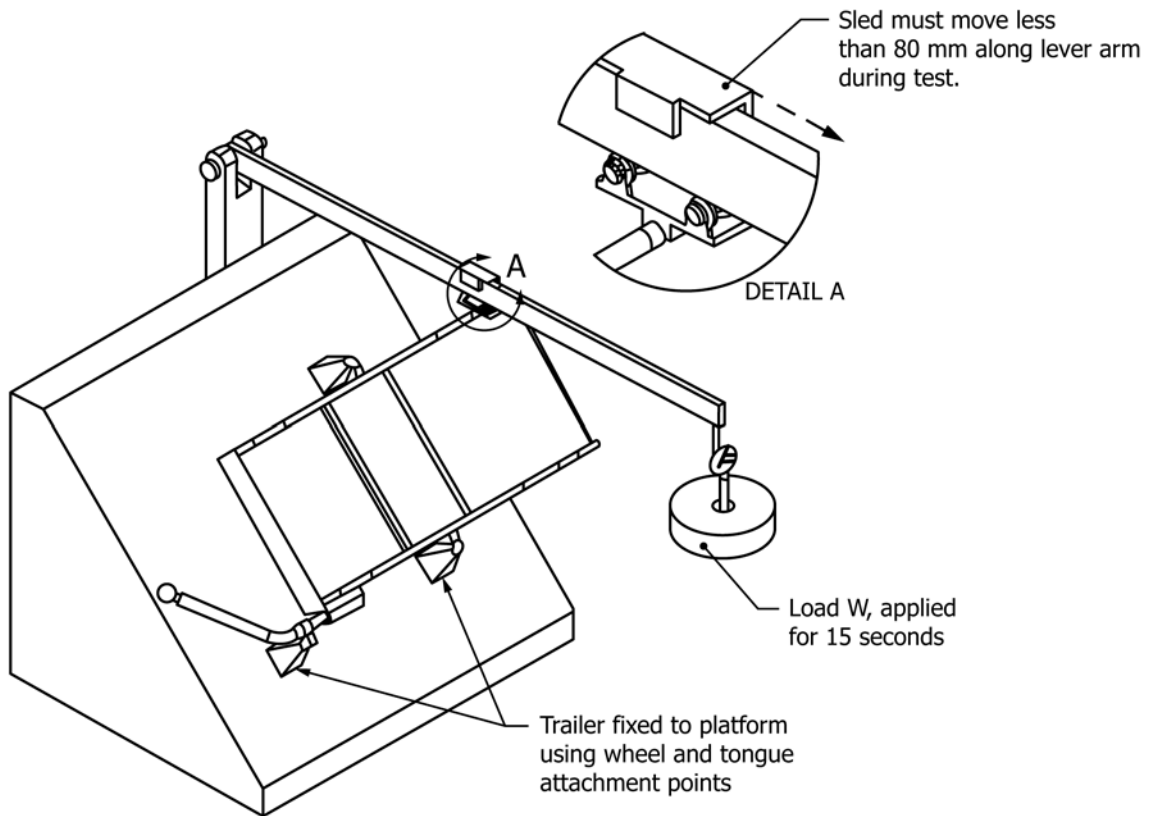

FIG. 3 Roll Test During Load Application

single-wheel trailer or multiple sets of cleats for a two-wheel

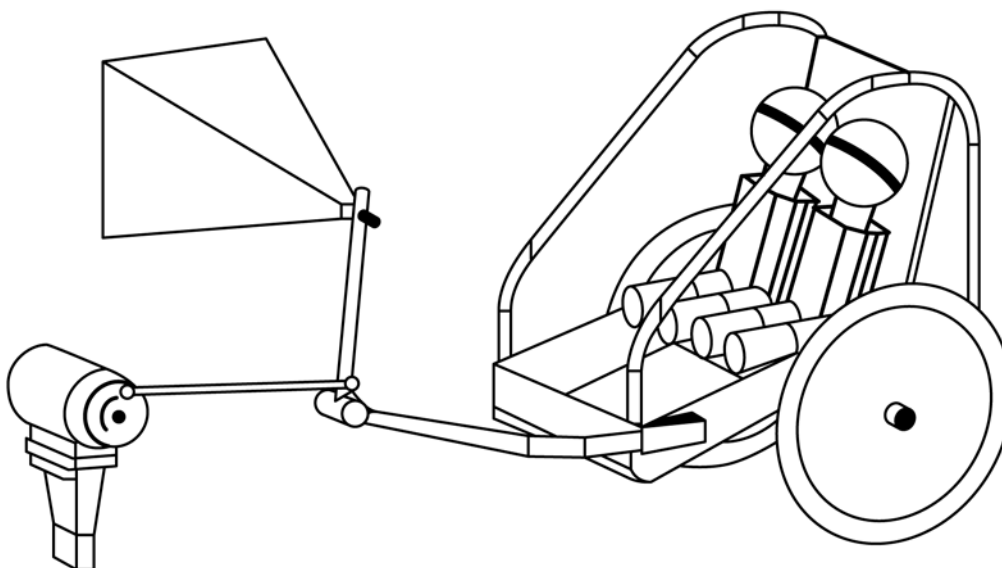

FIG. 4 Test Setup for Attaching Trailer to Typical Axle/Chainstay Mounted Coupling System

MEASUREMENTS IN MOTOR POSITION SHOWN:

- A: 330 ± 25 mm (13 ± 1.0 inch)
- B: 330 ± 25 mm
- C: 330 ± 25 mm
- D: 625 ± 50 mm (25 ± 2 inch)
- E: 320 ± 50 mm

IA-BI < 10 mm, IA-CI < 10 mm, IB-CI < 10 mm

R: $51 +0.5 -0.5$ mm (2 ± 0.020 inch)

L: > 250 mm (> 10 inch)

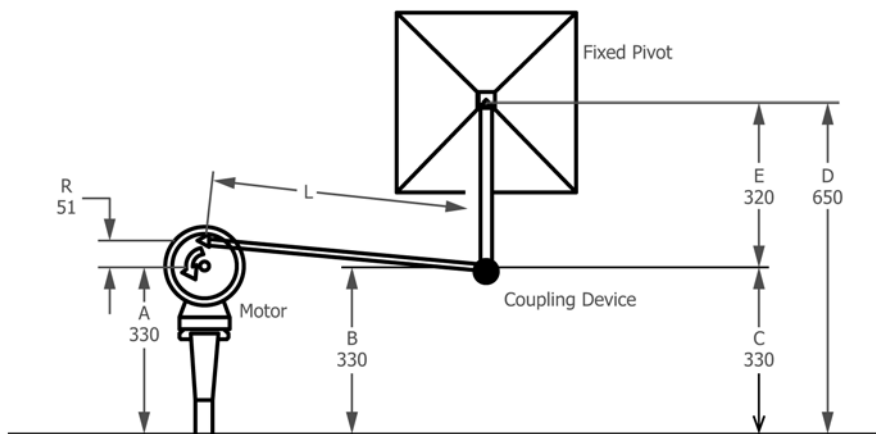

FIG. 5 Coupling System Test Setup

trailer are employed, the spacing shall ensure that each cleat strikes no less than a distance of 1016 mm (40 in.) after the previous cleat.

5.4.2 Erect the trailer in the manufacturer's suggested use configuration and restrain a dummy or dummies into the seat to attain full occupancy of the trailer. If the manufacturer has specified a separate location and capacity for cargo that is in addition to occupant capacity, then enough weight shall be added to the defined cargo area(s) to bring the total weight up to the manufacturer's total specified cargo and occupant weight. The total dummy and cargo weight shall meet or

exceed the manufacturer's specified maximum occupant and cargo weight. Inflate the tire(s) to the pressure stated on the tire sidewall or the trailer manufacturer's recommended tire pressure, whichever is higher. Mount the trailer onto the test equipment as previously described, and conduct the test for 20 000 wheel system impacts.

5.4.3 Remove the trailer from the test equipment and inspect the wheel and frame assemblies. No part of these assemblies shall fail, or incur a fracture or a crack. Inspect the interior of the trailer to ensure that there are no exposed holes or sharp objects. Inspect the dummies and seat restraints to

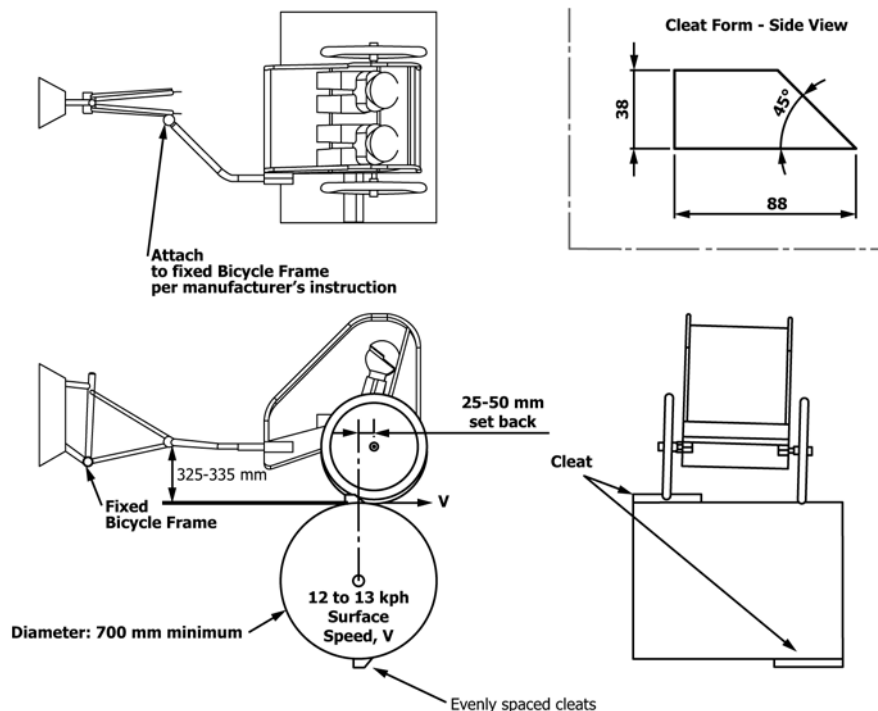

FIG. 6 Axle/Frame Fatigue Test

ensure that they are still in the proper seating positions, and that the restraints are not damaged beyond their functional limits.

5.5 Conspicuity:

5.5.1 Colors—It is desirable to make bicycle trailers highly visible to motorists and other road or trail users during daytime use by the use of bright contrasting colors, but this standard does not specify exact colors.

5.5.2 Flag—The trailer shall be equipped with a flag that is triangular in shape and made of high-visibility orange material. The flag shall be a minimum of 290 cm² (45 in.²) in area (580 cm² (90 in.²) of exposed surface area) in a vertical position, with the lower edge of the flag no lower than 1.37 m (4.5 ft) above the ground and the top edge of the flag no higher than 2.13 m (7.0 ft) above the ground. The manufacturer may imprint the surface of the flag with a logo or writing. The amount of imprinting cannot reduce the amount of highly visible surface area of the flag to less than 520 cm² (81 in.²).

6. Marking, Labeling, and Instructions

6.1 General—A trailer shall be permanently marked with information concerning the safe usage of the trailer. The markings shall be in locations easily visible to the assembler, installer, and user. The trailer shall also be accompanied by instructions on the proper assembly, attachment, usage, removal, disassembly, storage, and maintenance of the trailer, and general bicycle safety. Instructions shall be written in the native language(s) of the country(s) in which the trailer will be offered for sale, and attached to the trailer at the time of purchase by the original user.

6.2 Where Cautions, Warnings, and Danger signals are placed on the product by the manufacturer, they shall comply with the requirements of ANSI Z535.4.

6.3 Marking and Labeling—A trailer shall be permanently marked with the following information:

6.3.1 Name and address of the manufacturer or importer.

6.3.2 Month and year of manufacture.

6.3.3 Recommended maximum safe towing speed.

6.3.4 Seating diagram for each configuration of intended passengers up to the maximum recommended for the trailer, including proper positioning and fastening of harnesses and belts.

6.3.5 Proper inflation level for trailer tires.

6.3.6 Maximum weight capacity of trailer (passengers and cargo combined).

6.3.7 Minimum age or physical requirements, or both, for passengers.

6.3.8 Required passenger-fitted safety equipment, including helmets that comply to a recognized bicycle helmet performance standard.

6.3.9 Explanation of how attaching a trailer to a bicycle will affect the stability, braking, and riding characteristics of the bicycle.

6.3.10 A note to read the user instructions prior to use.

6.4 Labels shall be of durable materials, resistant to weather, fading, and abrasion, and shall be clearly visible on the trailer. Colors of informational labels (other than Caution, Warning, and Danger whose colors are defined in ANSI Z535.4) shall be

contrasting colors, such as black on white, and clearly distinguishable from Caution, Warning, and Danger labels. All labels shall be clearly visible as mounted on the trailer.

6.5 *Instructions:*

6.5.1 *Assembly*—If the trailer is sold in an unassembled or partially assembled condition, the manufacturer shall provide instructions on how to complete the assembly.

6.5.2 *Attachment*—The instructions shall include information on the procedures to attach the trailer to the bicycle. The instructions shall identify the features of the bicycle required for proper coupling.

6.5.3 *Usage*—The instructions shall provide the user with detailed information on how to use the trailer properly and safely. The following information is the minimum required for compliance with this specification:

6.5.3.1 Maximum weight capacity of the trailer (passengers and cargo combined).

6.5.3.2 Maximum number of passengers.

6.5.3.3 General instructions on riding a bicycle while pulling a trailer, plus maximum safe operating speed, both straight line and cornering.

6.5.3.4 Safety requirements for pulling a trailer with and without passengers

(1) Proper and safe positioning of the passenger(s) or cargo, or both, in the trailer and how to secure the harness and seat belt system around them.

(2) Use of available safety equipment (such as certified helmets).

(3) Minimum age or physical condition requirements for the passenger(s)

6.5.3.5 Explicit information on how the attachment of the trailer and the added weight of its passengers or cargo, or both, affect the handling characteristics of the bicycle to which it is attached.

6.5.3.6 A recommendation to the user that the bicycle to which the trailer will be attached undergo a safety check by a qualified bicycle mechanic before attaching the trailer to it.

6.5.3.7 Information concerning road, weather, or other conditions under which the trailer should *not* be used.

6.5.3.8 A warning to be cognizant of exposure hazards to less-active trailer occupants such as windchill and heat exhaustion, either by prolonged exposure in colder temperatures, or by extended periods in warmer temperatures without adequate ventilation or hydration.

6.5.3.9 Proper inflation level for trailer tires.

6.5.3.10 Notice not to use cleaning solvents; clean only with mild soap and water.

6.5.3.11 A recommendation to read the user instructions that came with the towing bicycle.

6.5.4 *Removal*—The instructions shall contain information for the user regarding the following:

6.5.4.1 Proper removal of passengers or cargo, or both, from the trailer.

6.5.4.2 Proper removal of the trailer from the bicycle.

6.5.5 *Disassembly and Storage:*

6.5.5.1 If after removal from the bicycle, the trailer requires partial or complete disassembly for storage, the instructions shall contain detailed information on the disassembly procedures.

6.5.5.2 The instructions shall include any specific information necessary for the safe storage of the trailer between uses, including any safety checks of components prior to the next usage.

6.5.6 *Maintenance*—If any routine or special maintenance is required or recommended by the manufacturer, the instructions shall set forth the items to be maintained and the maintenance frequency for each, and state whether this maintenance can be performed by the owner or is to be done by a professional bicycle mechanic.

6.5.7 *Warnings*—The following warning information shall be explained in the instructions.

6.5.7.1 Do not install inside the trailer a car seat or any other seating device not approved by the manufacturer .

6.5.7.2 Make no modifications to the trailer.

6.5.7.3 Do not allow any of the child's body, clothing, shoe laces, or toys to come in contact with moving parts.

6.5.7.4 Never leave a child unattended in the trailer.

6.5.7.5 Red reflector(s) shall be visible on the rear of the trailer.

6.5.7.6 Before each ride, ensure the attached trailer does not interfere with braking, pedaling, or steering of the bicycle.

6.5.7.7 Never ride a bicycle at night without adequate lighting. Obey all local legal requirements for lighting.

6.5.7.8 Failure to comply with the manufacturer's instructions can lead to serious injury or death of the passenger/rider.

6.5.7.9 Do not use with children who exceed the weight limitations.

6.5.7.10 Do not use cleaning solvents. Clean only with mild soap and water.

6.5.7.11 *This section applies to two-occupant trailers that provide a center seating position*—When used with only one occupant, the occupant should be seated in a center seating position.

7. Precision and Bias

7.1 Tests in this specification standard are pass or fail result. No numerical results are recorded.

8. Keywords

8.1 bicycle; bicycle trailer; trailer

ASTM International takes no position respecting the validity of any patent rights asserted in connection with any item mentioned in this standard. Users of this standard are expressly advised that determination of the validity of any such patent rights, and the risk of infringement of such rights, are entirely their own responsibility.

This standard is subject to revision at any time by the responsible technical committee and must be reviewed every five years and if not revised, either reapproved or withdrawn. Your comments are invited either for revision of this standard or for additional standards and should be addressed to ASTM International Headquarters. Your comments will receive careful consideration at a meeting of the responsible technical committee, which you may attend. If you feel that your comments have not received a fair hearing you should make your views known to the ASTM Committee on Standards, at the address shown below.

This standard is copyrighted by ASTM International, 100 Barr Harbor Drive, PO Box C700, West Conshohocken, PA 19428-2959, United States. Individual reprints (single or multiple copies) of this standard may be obtained by contacting ASTM at the above address or at 610-832-9585 (phone), 610-832-9555 (fax), or service@astm.org (e-mail); or through the ASTM website (www.astm.org). Permission rights to photocopy the standard may also be secured from the Copyright Clearance Center, 222 Rosewood Drive, Danvers, MA 01923, Tel: (978) 646-2600; <http://www.copyright.com/>