



Standard Practice for Installation of Barbed Tape¹

This standard is issued under the fixed designation F1911; the number immediately following the designation indicates the year of original adoption or, in the case of revision, the year of last revision. A number in parentheses indicates the year of last reapproval. A superscript epsilon (ϵ) indicates an editorial change since the last revision or reapproval.

1. Scope

1.1 This practice covers the installation procedure for barbed tape.

1.2 The primary purpose of this practice is to guide those responsible for or concerned with the installation of barbed tape on chain link fences, masonry walls, roofs or used as ground barriers. This standard is not intended to cover aspects of perimeter security for establishing levels of product performance or give analysis relating to various design comparisons.

1.3 This standard involves the use of material, that may cause injury, including exposure to hazardous materials, and operation of specialized equipment.

1.4 The values stated in inch-pound units are to be regarded as standard. No other units of measurement are included in this standard.

1.5 *This standard does not purport to address all of the safety concerns, if any associated with its use. It is the responsibility of the user of this standard to establish appropriate safety and health practices and determine the applicability of regulatory limitations prior to use.*

2. Referenced Documents

2.1 *ASTM Standards:*²

F1379 Terminology Relating to Barbed Tape

F1910 Specification for Long Barbed Tape Obstacles

F1916 Specifications for Selecting Chain Link Barrier Systems With Coated Chain Link Fence Fabric and Round Posts for Detention Applications (Withdrawn 2008)³

3. Terminology

3.1 Refers to Terminology F1379.

¹ This practice is under the jurisdiction of ASTM Committee F14 on Fences and is the direct responsibility of Subcommittee F14.40 on Chain Link Fence and Wire Accessories.

Current edition approved March 1, 2015. Published March 2015. Originally approved 1998. Last previous edition approved 2010 as F1911-05(2010). DOI: 10.1520/F1911-05R15.

² For referenced ASTM standards, visit the ASTM website, www.astm.org, or contact ASTM Customer Service at service@astm.org. For *Annual Book of ASTM Standards* volume information, refer to the standard's Document Summary page on the ASTM website.

³ The last approved version of this historical standard is referenced on www.astm.org.

4. Significance and Use

4.1 This practice is intended to provide standard requirements utilizing specialized equipment and hand tools.

4.2 Ensure that the barbed tape is fabricated from acceptable material and well constructed. Field verification of the barbed tape's acceptability shall be in accordance with the project's specifications and this specification.

5. Site Preparation

5.1 The owner shall specify the location in which the barbed tape shall be installed by furnishing drawings or personal instruction.

5.2 Barbed tape obstacles shall be in accordance with Specification F1910 barbed tape specifications.

NOTE 1—Refer to Terminology F1379 for barb configuration and cross sections.

6. Installation

6.1 When the specifications are unclear, refer to these instructions or contact the owner for information covering placement, coil attachment, splicing, etc.

6.2 *Non-Reinforced (Concertina):*

6.2.1 *Description*—Barbed obstacle capable of being permanently or temporarily installed. Barbed tape used for some temporary installations shall have the ability of being recovered and used repeatedly.

6.2.2 *Top of the Fence Installation*—Barb Arms are recommended for top of the fence installations. Single 45° barb arms with a single strand of barbed wire or tension wire located in the outer position of the arm will support coils deployed at the top of the fence. Barb arms are positioned so that arms are out of reach from the approach side. “V” arms are not recommended for security applications where climbing is a threat or where only one row of barbed tape is specified. Two rows of barbed tape are recommended where “V” arms are specified. See Fig. 1.

6.2.2.1 *Deployment*—Stretch the coils out and allow them to rotate (spiral) naturally around their central axis. Allowing the coil to rotate will ensure that there is no mechanical stress within the obstacle before tying. Locate the coil loops uniformly at the specified coil spacing. The coil spacing is predetermined by one or more permanently attached cables

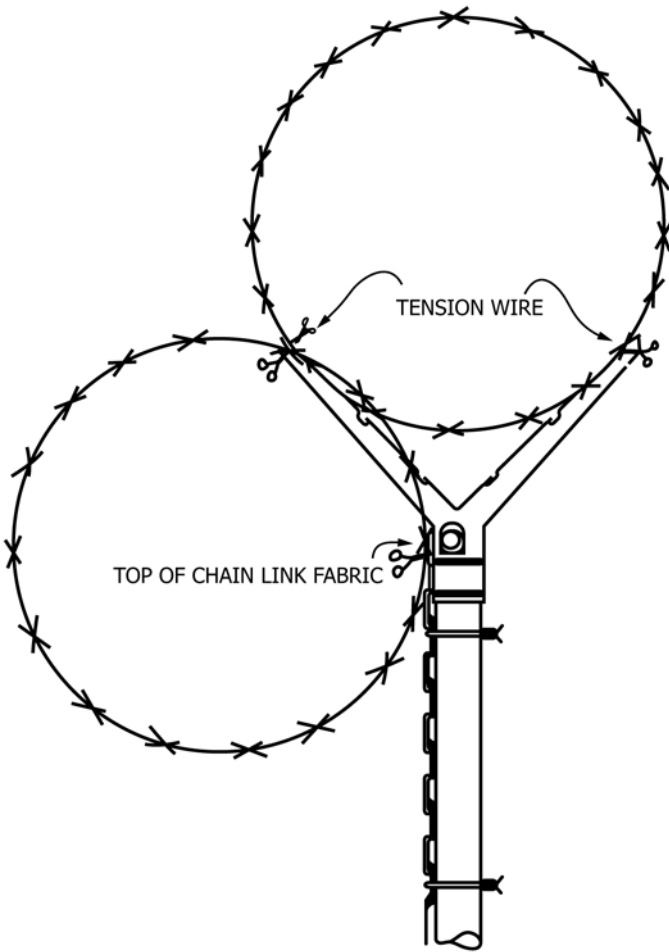

FIG. 1 “V” Arm Installation Wire-Reinforced and Non-Reinforced Barbed Tape Concertina.

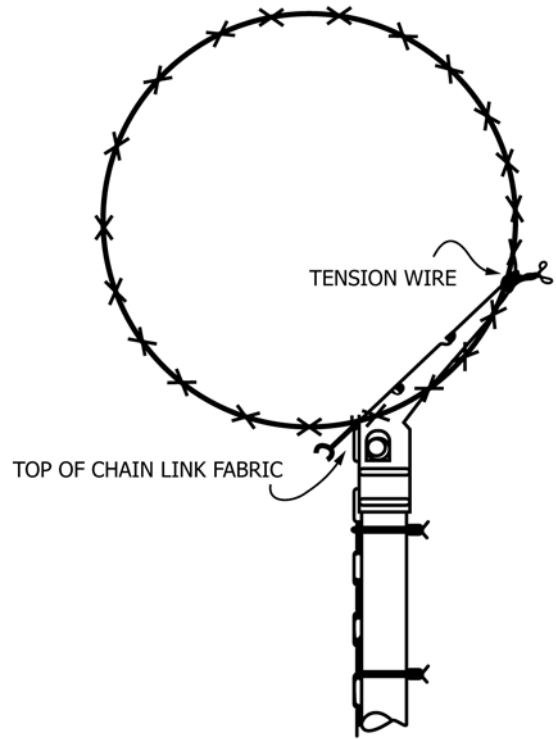

FIG. 2 45° Arm Installation Wire Reinforced and Non-Wire Reinforced Barbed Tape Concertina

running the entire length of the roll. The number of cables depends largely on the diameter and application. Coil loop spacing for non-reinforced products are generally 12.0 in. See Fig. 2.

6.2.2.2 *Tie Points*—Before making the final attachment to the fence, inspect the coils for tangles and proper coil spacing. Attach the first ties to the single strand of barbed wire, cable or tension wire located in the barb arm. Tie parallel coil loops at the desired spacing, determined by the spacer cable. Attach the second tie points to the top of the chain link at the desired spacing. Tie wires for detention applications are stainless steel 16 gage minimum, for commercial and industrial applications stainless steel 18 gage minimum is adequate. Large stainless steel hog rings with a minimum cross section of 12½ gage, may be used. Hog rings are not recommended where electronic detection is an integral part of the barrier system. For high security application, the hog ring cross section must be strong enough to prevent opening the ring by pulling on the barbed tape.

6.2.3 *Side of The Fence Installation* —Coils shall be installed horizontally on the approach side of the fence. Design criteria will obviously change depending on the threat.

6.2.3.1 *Deployment*—Follow deployment instructions described for top of the fence (6.2.2.1).

6.2.3.2 *Tie Points*—Before making the final attachment to the fence, inspect the coil for tangles and proper coil loop spacing. Improper coil loop spacing and tangles will reduce the coil’s specified yield length. Attach the parallel coil loops to the fence fabric at the desired spacing determined by the spacer cables. Every coil intersecting the fence need not be tied. Ties for detention applications are stainless steel 16 gage minimum; for commercial and industrial applications stainless steel 18 gage minimum is adequate. Large stainless steel hog rings capable of providing an overlapping wrap around both the chain link and barbed tape may be used. Hog rings are not recommended where electronic detection is an integral part of the barrier system.

6.2.4 *Bottom of the Fence Installation*—Ground barriers are coils placed horizontal, in vertical stacks at the base of the fence and tied consecutively together. Stacked coils are tied approximately 36 in. to 48 in. on center (o.c.) to adjacent rows. See Fig. 3.

6.2.4.1 *Deployment*—Follow deployment instructions described in (6.2.2.1).

6.2.4.2 *Tie Points*—Follow tying instructions from 6.2.3.2.

6.2.5 *Splicing*—Connect the trailing end of an installed roll and the leading end of an un-installed roll. Connect the two rolls at the point where the cable (or cables) from each roll come together. Tie the cable loops and closest barb cluster together with the minimum 18 gage stainless steel tie wire. This tie secures the ends of the cables and matching barb clusters together. Maintain a uniform diameter by aligning the remaining barb clusters around the perimeter of the coil. Complete the splice by tying the end turns of the leading and trailing rolls together. Place additional ties where the coils

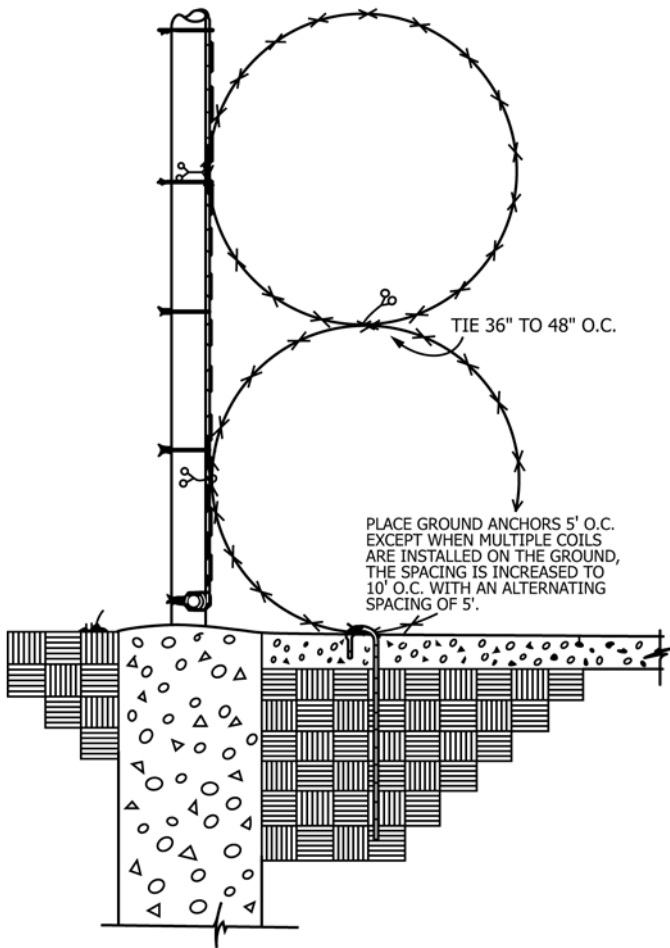

FIG. 3 Side and Bottom of Fence Installation Wire Reinforced and Non-Reinforced Barbed Tape Concertina.

would have been spot welded if manufactured into one continuous roll. Additional ties may be required to strengthen or improve on the appearance of the splice.

NOTE 2—It is important that larger diameter coils with two or more cables have at least one cable continue uninterrupted through the entire run. This prevents diameter distortion at the splice.

6.2.6 *Ground Anchors*—Coils deployed on the ground shall be anchored as required, depending on the application and security threat. For security applications, place ground stakes 5 ft. o.c. Multiple coils on the ground for high security applications; stakes are generally 10 ft o.c. with an alternating offset pitch of 5 ft between rows. Length and type of anchors are determined in accordance with inherent weather and soil conditions.

6.3 *Non-Reinforced 24/30 in. Double Coil (Helical Type II):*

6.3.1 *Description*—Double coil Type II is constructed of one 24 in. diameter helical coil inside a 30 in. diameter helical coil. Inner and outer coils are alternately joined together with four cables at a predetermined spacing. Type II barbed tape is the only barbed obstacle having a top and bottom. The bottom is located mid distance between the shorter pair of spacer cables. See Fig. 4.

6.3.2 *Top of the Fence Installation* —Barb arms are recommended for top of the fence installations. Single 45° barb arms with a single strand of barbed wire, tension wire or 3/16 in. diameter cable, located in the outer position of the arm will support coils deployed at the top of the fence. Barb arms are positioned so that the arms are out of reach from the approach side of the obstacle.

6.3.2.1 *Deployment*—Stretch the coil out and locate the coil loops uniformly as predetermined by the four spacer cables. Rotate the entire coil assembly approximately 45°; positioning the bottom, mid way between the tension wire and top of the fence fabric. Inner and outer coil spacings are fixed at 24 in. The alternating offset spacing between the inner and outer coils is 12 in. o.c. at the bottom of the obstacle.

6.3.2.2 *Tie Points*—Before making the final attachment to the fence, inspect the coils for tangles and proper coil spacing. The inner and outer coils shall be securely attached in two locations: one to the barbed wire, tension wire or cable located in the barb arm and the other to the top of the fence fabric. See Fig. 5. For installations using “V” arms; a second row of barbed tape shall be installed to prevent using the arm as a breaching aid. To reduce distortion as a result of adverse weather conditions, spacer cables shall remain tight throughout

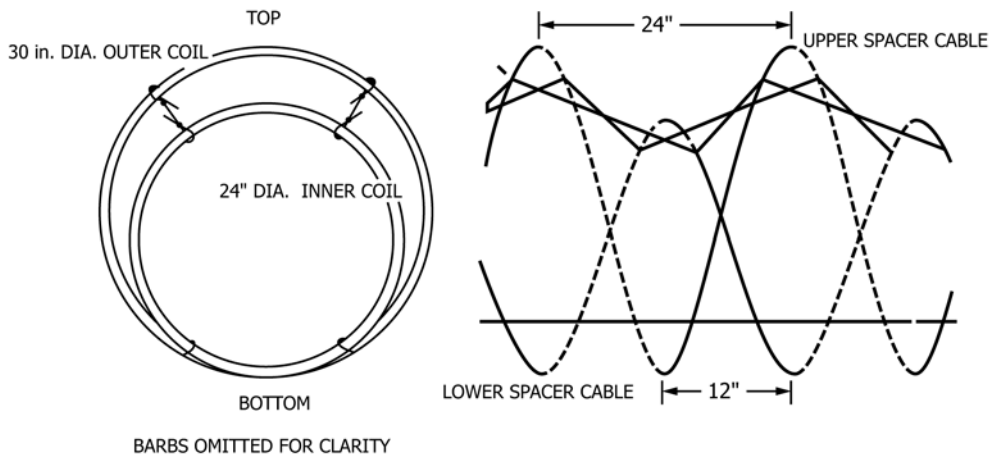

FIG. 4 Double Coil Non-Reinforced

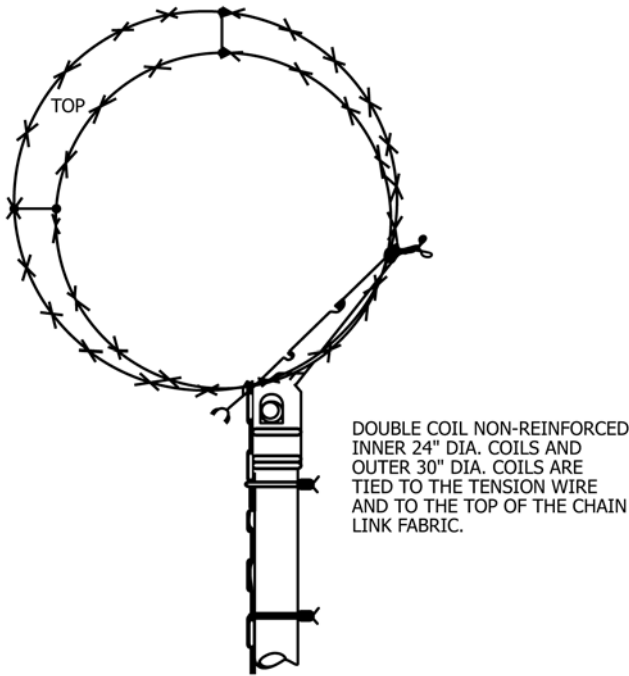

FIG. 5 Top of the Fence 45° Barb Arm Installation

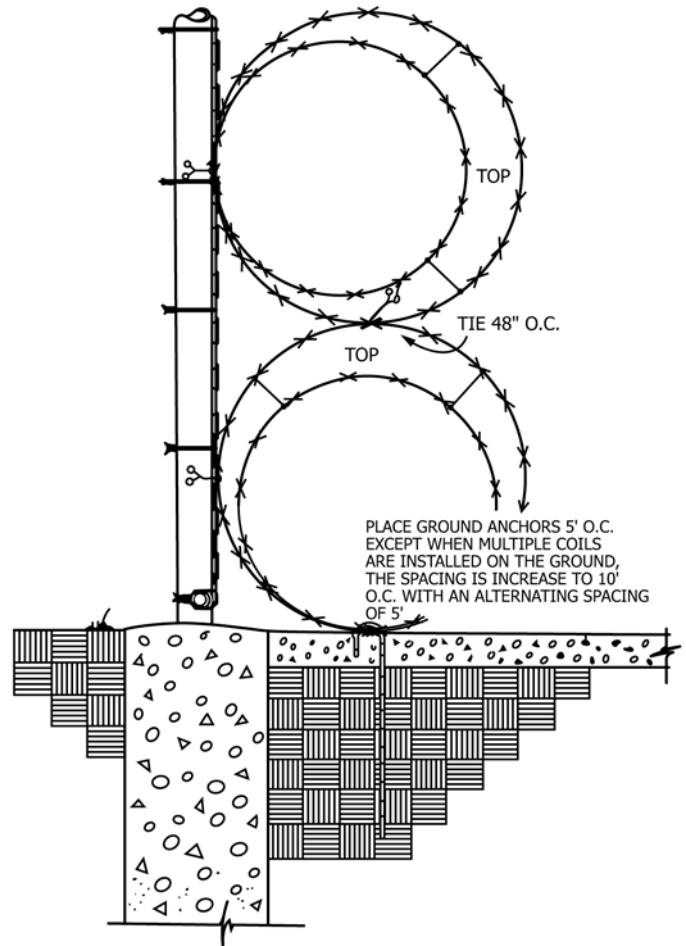

FIG. 7 Side and Bottom of the Fence Installation Non-Reinforced Barbed Tape

the installation. 16 gage, minimum, stainless steel ties are used to secure barbed obstacles to the fence. See Fig. 6.

6.3.3 *Side of the Fence Installations*—Coils shall be installed horizontally on the approach side of the fence. Design criteria will obviously change depending on the threat.

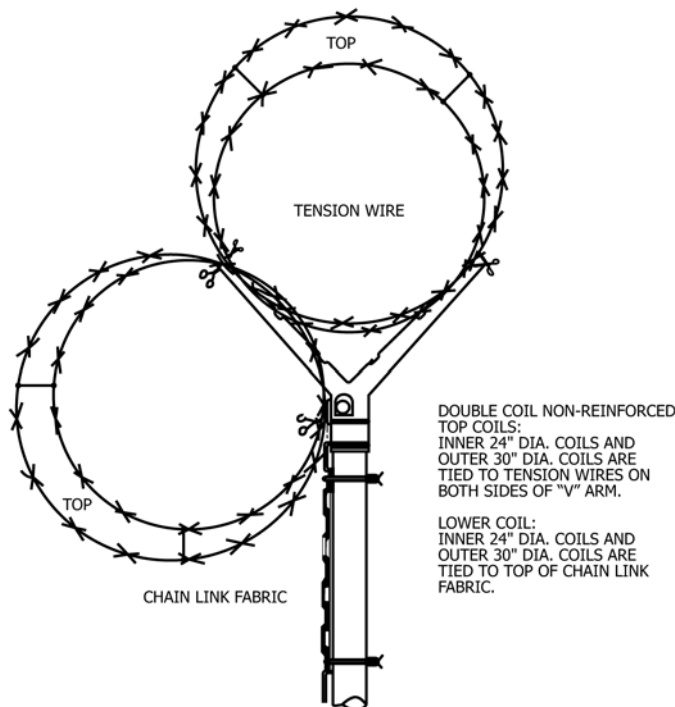

FIG. 6 Top of the Fence "V" Arm Installation

6.3.3.1 *Deployment*—Follow the same procedure for deployment as described in 6.2.3.1, except, that after dispensing the coil, rotate the coil assembly 90° and place the bottom of the obstacle against the fence.

6.3.3.2 *Tie Points*—Attach the inner and outer coil loops to the fence fabric 12 in. o.c. 16 gage minimum stainless tie wires are used for this purpose.

6.3.4 *Bottom of the Fence Installations*—Coils at the base of the fence shall be installed with the bottom of the coil resting on the ground or prepared surfaces. Consult with the manufacturer for information covering coil stacking or unusual finished grade conditions that may cause installer to deviate from the standard installation.

6.3.4.1 *Deployment*—Follow the same procedure for deployment as described in 6.3.2.1, except, that after dispensing the coil, the bottom of the obstacle shall rest on the ground.

6.3.4.2 *Tie Points*—Attach the outer coil loops to the fence fabric 24 in. o.c. 16 gage minimum stainless tie wires are used for this purpose. Adjacent coils stacked vertically and running horizontally are tied together approximately 48 in. o.c. throughout the stack.

6.3.5 *Splicing*—Connect the trailing end of the installed roll and the leading end of the un-installed roll. Connect the two rolls at the point where the four spacer cables terminated at the

end turns. Adjust the rolls so that the top of each roll is relative to one another. Align the four spacer cables and matching barb clusters. At each attachment point, tie the two cables and matching barb clusters together. Complete the splice with 16 gage stainless steel tie wires diagonally across the barb. Hog rings may be used if they are designed for the purpose. Repeat this procedure for the remaining cables, as if they were manufactured into one continuous roll. Additional ties may be required to strengthen or improve on the appearance of the splice.

6.3.6 *Ground Anchors*—Coils deployed on the ground shall be anchored as required, depending on the application and security threat. For security applications, place ground stakes 5 ft. o.c.. Multiple coils on the ground for high security applications: stakes are generally 10 ft. o.c. with an alternating offset pitch of 5 ft. between rows. Length and type of anchors are determined in accordance with inherent weather and soil conditions.

6.4 *Wire Reinforced, (Single Coil Concertinas),*

6.4.1 *Description*—Diameters ranging from 18 in. to 61 in. are fabricated by cold clinching the flat barbed portion of the tape around a core wire. Adjacent alternate loops are clipped together around the circumference, creating the concertina effect.

6.4.2 *Top of the Fence Installation*—Barb arms are recommended for top of the fence installations. Single 45° barb arms with a single strand of barbed wire or tension wire located in the outer position of the arm will support coils deployed at the top of the fence. Barb arms are positioned so that arms are out of reach from the approach side. “V” arms are not recommended for security applications where climbing is a threat or where only one row of barbed tape is specified. Two rows of barbed tape are recommended where “V” arms are specified. See Fig. 1.

6.4.2.1 *Deployment*—Stretch the coil out and allow it to rotate naturally around its central axis. Allowing it to rotate will ensure that there is no mechanical stress within the obstacle before tying. Locate the coil loops uniformly at the specified coil spacing. Coil loop spacings for concertina products will vary depending on the coil configuration and number of clips.

6.4.2.2 *Tie Points*—Before making the attachment to the fence, inspect the coils for tangles and proper coil spacing. Attach the first group of ties to the single strand of barbed wire, cable or tension wire located in the barb arm. Tie parallel coil loops at the desired spacing. Attach the second group of ties to the top of the chain link at the desired spacing. Tie wires for detention applications are stainless steel 16 gage minimum, for commercial and industrial applications stainless steel 18 gage minimum is adequate. Large stainless steel hog rings with a minimum cross section of 12½ gage, may be used. Hog rings are not recommended where electronic detection in an integral part of the barrier system. For high security application, the hog ring cross section must be strong enough to prevent opening the ring by pulling on the barbed tape.

6.4.3 *Side of the Fence Installation*—Coils shall be installed horizontally on the approach side of the fence. Design criteria will obviously change depending on the threat.

6.4.3.1 *Deployment*—Stretch the coils out and allow them to rotate (spiral) naturally around their central axis. Allowing the coil to rotate will ensure that there is no mechanical stress within the obstacle before tying. Locate the coil loops uniformly at the specified coil spacing. Coil loop spacing for concertina products will vary depending on the coil configuration and number of clips. Coil loop spacings for wire reinforced products are generally 12.0 in. See Fig. 2.

6.4.3.2 *Tie Points*—Before making the attachment to the fence, inspect the coils for tangles and proper coil spacing. Attach the parallel coil loops to the side of the fence using twistable tie wires. Ties for detention applications are stainless steel 16 gage minimum. For commercial and industrial applications stainless steel 18 gage minimum ties are adequate. Large stainless steel hog rings used for this purpose should be of sufficient size to wrap completely around the tape and fabric with an overlap.

6.4.4 *Bottom of the Fence Installation*—Coils installed at the base of the fence are placed horizontal in vertical stacks and tied consecutively together. Stacked coils are tied approximately 36 in. to 48 in. o.c. to adjacent rows. See Fig. 3.

6.4.4.1 *Deployment*—Stretch the coils out and allow them to rotate (spiral) naturally around their central axis. Allowing the coil to rotate will ensure that there is no mechanical stress within the obstacle before tying. Locate the coil loops uniformly at the specified coil spacing. Coil loop spacings for concertina products will vary depending on the coil configuration, number of clips and barrier density. See Fig. 2.

6.4.4.2 *Tie Points*—Follow instructions for tying described in 6.4.3.2. See Fig. 3.

6.4.5 *Splicing*—Connect the trailing end of the installed roll and the leading end of the un-installed roll. Aligning the clips from the leading and trailing rolls will allow the splicing tails to overlap a minimum of one barb cluster. Tie the overlapping barbs together (diagonally across the barbs) so as not to allow one barb from slipping past the other. Complete the splice by placing additional ties around the perimeter of splice where clips would have been installed if manufactured into one continuous roll.

NOTE 3—Short barb military concertinas are not equipped with splicing tails: complete the splice by tying the end coils together approximately where clips would have been if manufactured in one continuous roll.

6.4.6 *Ground Anchors*—Coils deployed on the ground shall be anchored as required, depending on the application and security threat. For security applications, place ground stakes 5 ft. o.c. Multiple coils on the ground for high security applications: stakes are generally 10 ft o.c. with an alternating offset pitch of 5 ft between rows. Length and type of anchors are determined in accordance with inherent weather and soil conditions.

6.5 *Wire Reinforced (Double Coil Concertina):*

6.5.1 *Description*—Double coil concertina units are constructed of a smaller diameter coil placed inside a larger diameter coil with the ends fastened together to aid in deployment. Each concertina coil is fabricated by cold clinching the flat barbed portion of the tape around a core wire. Adjacent alternating loops are clipped together around the circumference creating the concertina effect.

6.5.2 *Top of The Fence Installation*—Barb Arms are recommended for top of the fence installations. Single 45° barb arms with a single strand of barbed wire or tension wire located in the outer position of the arm will support the double coil unit deployed at the top of the fence. Barb arms are positioned so that arms are out of reach from the approach side. “V” arms are not recommended for security applications where climbing is a threat or where only one double coil unit is specified. Two rows of barbed tape are recommended where “V” arms are specified. See Fig. 1.

6.5.2.1 *Deployment*—Stretch the unit out and allow the coils to rotate (spiral) naturally around its central axis. Allowing the coil to rotate will ensure that there is no mechanical stress within the obstacle before tying. Locate the inner and outer coil loops uniformly at the specified coil spacing. Coil loop spacings for double coil concertina products may vary depending on the coil configuration and clipping arrangement.

6.5.2.2 *Tie Points*—Before making the final attachment to the fence inspect the coils for tangles and proper coil spacing. When fully deployed, the inner coil loops are approximately located between the outer coil loops. Attach the outer coil loops to the single strand of barbed wire, cable or tension wire located in the barb arm. Tie parallel coil loops at the desired spacing. The second group of ties, secure the outer coil loops to the top of the chain link at the desired spacing. Where electronic detection is an integral part of the barrier system, the inner coil is also tied to the top of the chain link fabric. Tie wires for detention applications are stainless steel 16 gage minimum, for commercial and industrial applications stainless steel 18 gage minimum is adequate. Stainless steel hog rings with a minimum cross section of 12 ½ gage, may be used. Hog rings used for this purpose shall be of sufficient size to wrap completely around the tape and fabric with an overlap. See Fig. 8.

6.5.3 *Side of the Fence Installations* —Coils shall be installed horizontally on the approach side of the fence. Design criteria will obviously change depending on the threat. Consult with the manufacturer for alternative methods of installations.

6.5.3.1 *Deployment*—Stretch the coil out and allow it to rotate (spiral) naturally around its central axis. Allowing the coils to rotate will ensure that there is no mechanical stress within the obstacle before tying. Locate the inner and outer coil loops uniformly at the specified coil loop spacing. Coil loop spacings for double coil concertina products may vary depending on the coil configuration and clipping arrangement.

6.5.3.2 *Tie Points*—Before making the final attachment to the fence fabric, inspect the coils for tangles and proper coil spacing. When fully deployed the inner coil loops are approximately located between the outer coil loops. Attach the outer coil loops to the side of the fence; by tying parallel coil loops at the desired spacing. Where electronic detection is an integral part of the barrier system, the inner coil is also tied to the side of the fence. Tie wires for detention applications are stainless steel 16 gage minimum, for commercial and industrial applications stainless steel 18 gage minimum is adequate. Stainless steel hog rings with a minimum cross section of 12 ½ gage, may be used. Hog rings used for this purpose shall be of

sufficient size to wrap completely around the tape and fabric with an overlap. See Fig. 9.

6.5.4 *Bottom of the Fence Installation*—Coils at the base of the fence are placed horizontal in vertical stacks and tied consecutively together. Stacked coils are tied approximately 36 in. to 48 in. o.c. to adjacent rows. See Fig. 3.

6.5.4.1 *Deployment*—Stretch the coil out and allow it to rotate (spiral) naturally around its central axis. Allowing it to rotate will ensure that there is no mechanical stress within the obstacle before tying. Locate the inner and outer coil loops uniformly at the specified coil loop spacing, both the inner and outer coils will rest on the ground. Coil loop spacings for double coil concertina products may vary depending on the coil configuration and clipping arrangement.

6.5.4.2 *Tie Points*—The outer coil is secured in the same manner as described in 6.5.3.2, except the inner coil will rest on the ground or prepared surface.

6.5.5 *Splicing*—Connect the trailing ends of the double coil unit to the leading ends of the un-installed unit. Aligning the clips from the leading and trailing end of the inner coil will allow the splicing tails to overlap a minimum of one barb cluster. Tie the overlapping barbs together (diagonally across the barbs) to prevent one barb from slipping past the other. Complete the splice by placing an additional tie approximately 180° across from the overlapping splice, where attaching clips would have been if manufactured in one continuous roll. Larger diameter double coil units may require more than one splicing tie on the opposite side away from the overlap. Repeat the above procedure for the outer coil.

NOTE 4—If coils are allowed to rotate around their central axis, during installation, you may choose to remove the ring or cable attachment joining the end coil loops together. Removing the end attachments during the splicing operations, permits the inner coil to assume its natural position when secured to the fence or resting in the bottom of the outer coil.

6.5.6 *Ground Anchors*—Coils deployed on the ground shall be anchored as required, depending on the application and security threat. For security applications; place ground stakes 5 ft o.c. Multiple coils on the ground for high security applications: stakes are generally 10 ft o.c. with an alternating offset pitch of 5 ft between rows. Length and type of anchors are determined in accordance with inherent weather and soil conditions.

NOTE 5—Tying the inner diameter coil to the top and side of the fence is not necessarily limited to those installations specifying electronic detection. Tying the inner coil provides greater strength and stability to the barrier system.

6.6 *Wire Reinforced (Single Helical Coils):*

6.6.1 *Description*—Coil Diameters up to 25 in. are fabricated by cold clinching the flat barbed portion of the tape around a core wire. There are no attaching clips around the circumference, except for manufactured, in line, splice connections.

NOTE 6—Before untying the roll, while the barb clusters are still aligned in the packaged condition, paint one row of barb clusters with a bright color. The brightly painted barb clusters will serve as a point of reference for tying the tape in place at the top or side of the fence; including roof and wall mounted tension wires.

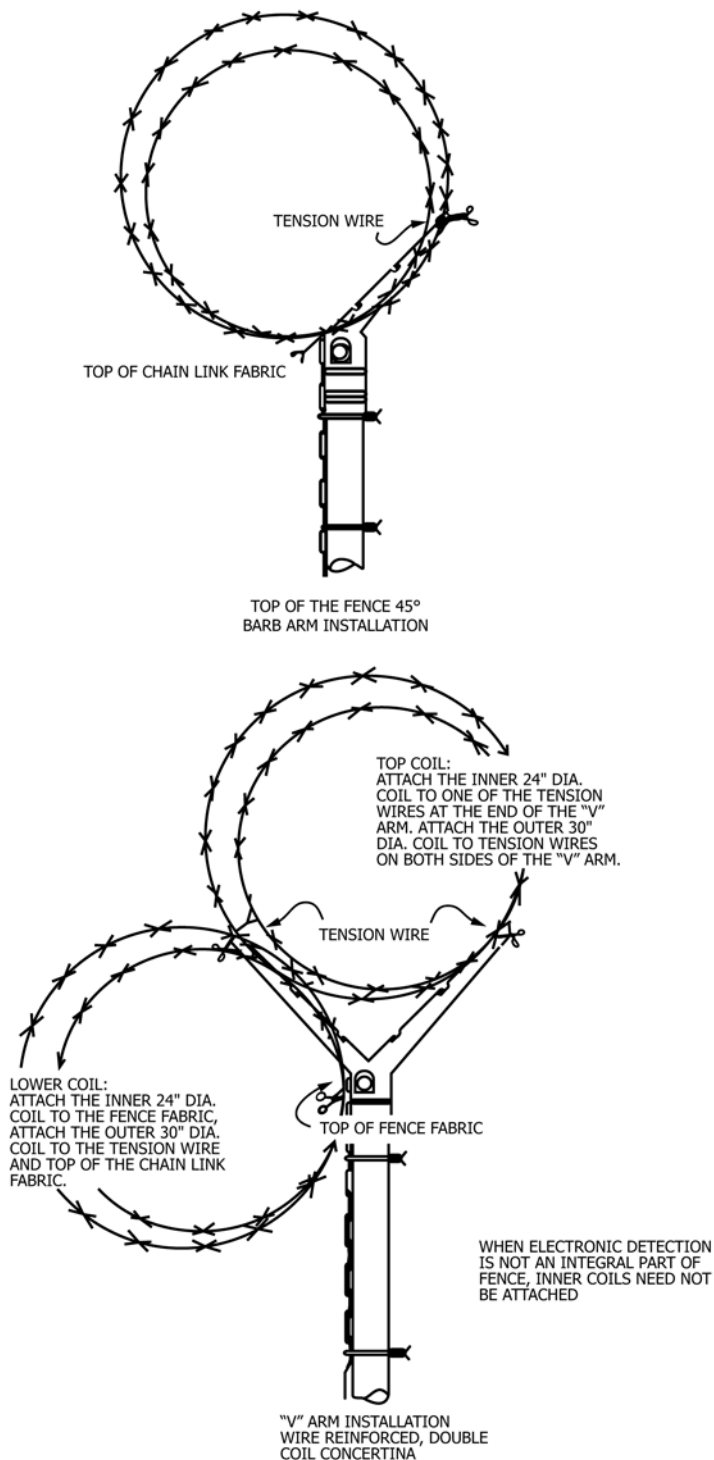

FIG. 8 Wire Reinforced Double Coil Concertina

6.6.2 *Top of the Fence Installation*—The following fence toppings are primarily used for industrial/commercial applications. The following methods of attachment are commonly used: extended line and terminal post with barbed wire or tension wire, 45° barb arms or “V” barb arms with barbed wire, no arms with top rail and no arms with top tension wire.

6.6.2.1 *Deployment*—After removing the bundling ties, uncoil the helical coils one by one and place them at the specified spacing.

6.6.2.2 *Tie Points*—Attach the dispensed coils from the opposite side of the fence. 12 ½ in. gage minimum hog ring or 18 in. gage minimum tie wires are used for this purpose. The wires and hog ring materials shall be compatible to that of the barbed tape.

6.6.3 *Side of the Fence Installation*—Coils shall be installed horizontally on the approach side of the fence. Design criteria will obviously change depending on the threat. Consult with the manufacturer for alternative methods of installations.

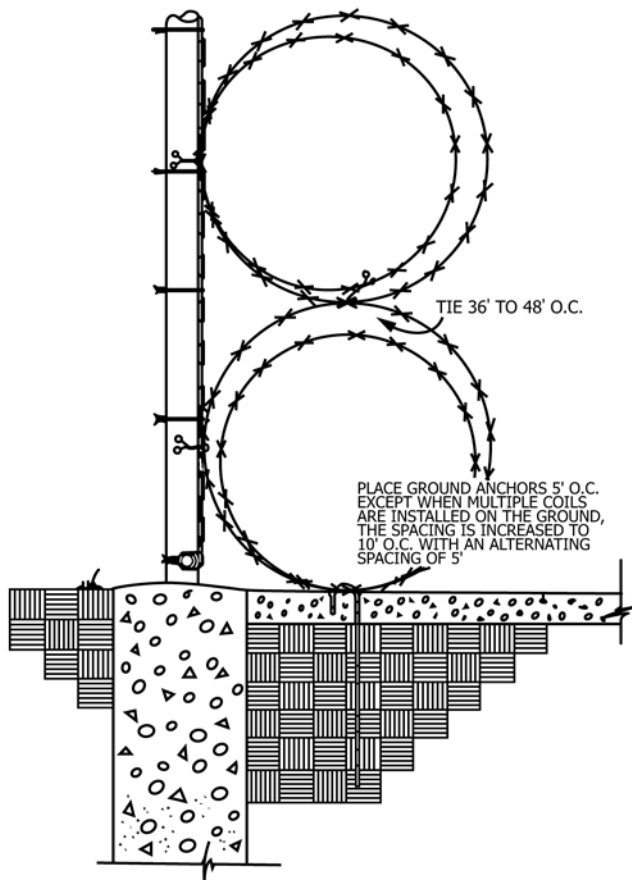

FIG. 9 Side and Bottom of Fence Installation Wire Reinforced Double Coil Concertina

6.6.4 *Splicing*—Overlap the leading and trailing ends of the barbed tape a minimum of one barb cluster. Tie the barb clusters (diagonally across the barb) together using 18 gage stainless steel or 16 gage zinc coated tie wires. Hog rings may also be used for this purpose.

NOTE 7—Placement and tying of coils to the fence will appear similar to those in Fig. 1, Fig. 2, Fig. 3, and Fig. 10.

NOTE 8—Helical barbed tape for industrial/commercial applications is easily adapted to numerous structures not shown. For additional information contact the manufacturer.

6.7 *Roll Formed Helical Coil with No Reinforcing Wire,*

6.7.1 *Description*—12, 18, and 24 ft diameter barbed tape with a geometrical stiffening groove running longitudinally through the center of the tape. All installation instructions are similar to those described in 6.5 for helical coils, wire reinforced barbed tape.

7. Installation Tolerances

7.1 *Concertina Security Coils*—Security coil’s yield length is proportional to coil loop spacings. See Table 1.

7.1.1 *Concertina Coil Diameters*—Concertina security coils will reduce in diameter, proportional to the coil loop spacing: for each inch of coil loop spacing, the diameter will reduce approximately 3/32 in.

7.2 *Helical Security Coils*—Helical coil’s yield length is proportional to coil loop spacings. See Table 2.

7.2.1 *Helical Coil Diameters*—All helical security coils will reduce in diameter, proportional to the coil loop spacing: for each inch of coil loop spacing, the diameter will reduce approximately 1/32 in.

7.3 *Minimum Height (warning)*—Barbed tape installed on fences and walls shall have a minimum height of 7 ft to the bottom of the coil. If lower heights or ground installations are required, additional intermediate fencing is mandatory to restrict access and prevent accidental encounters with the barriers.

8. Keywords

8.1 barbed tape; barbed tape, installation

6.6.3.1 *Deployment*—Follow deployment procedures described in 6.5.3. The coil shall *not* rotate around its central axis, and every coil *will* be tied to the fence.

6.6.3.2 *Tie Points*—Helical coil are secured in the same manner described in 6.5.2.2.

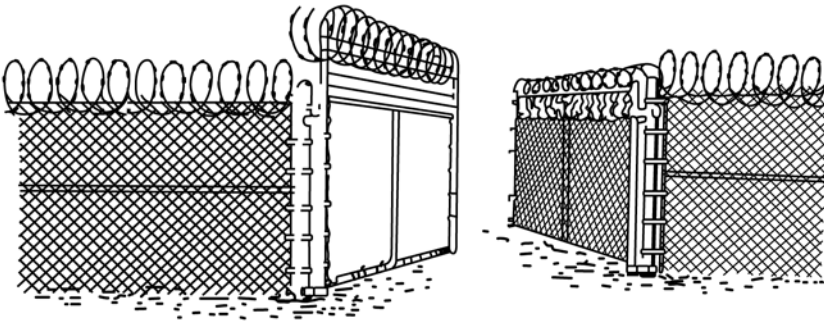

GATE VARIATIONS

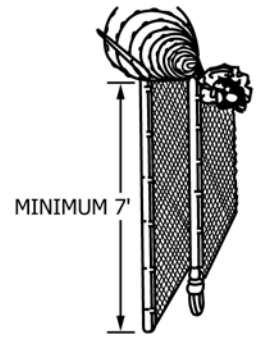

FENCE & SLIDING GATE

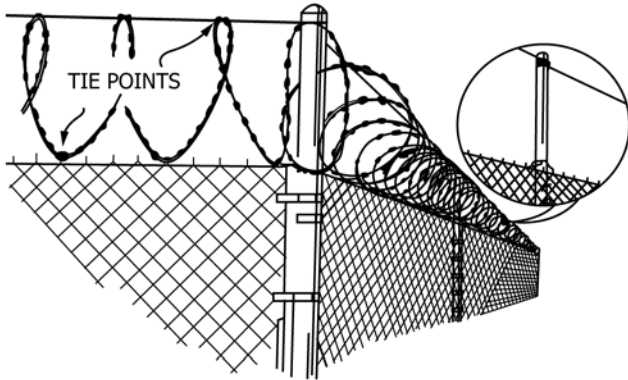

EXTENDED LINE POST

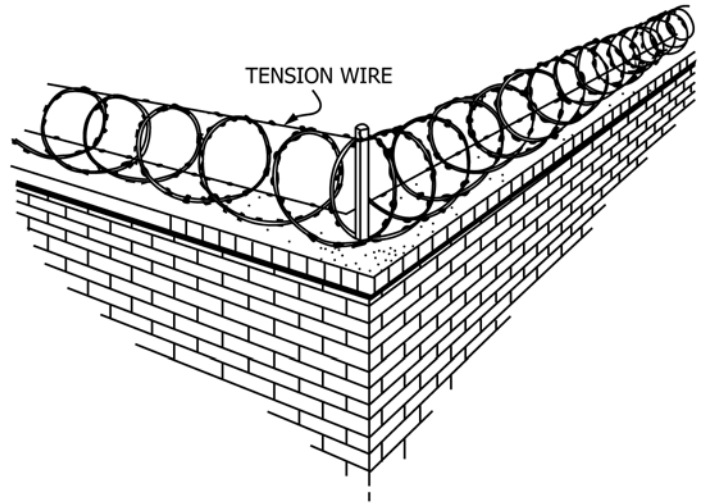

TOP OF WALL

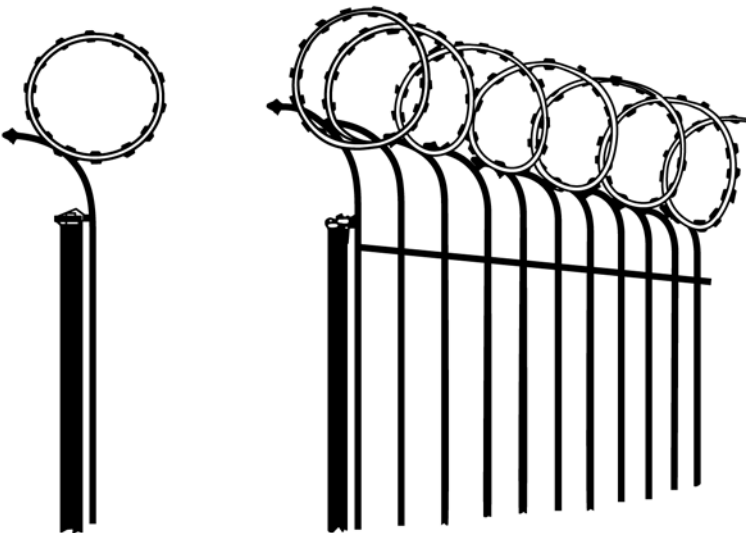

DECORATIVE FENCE

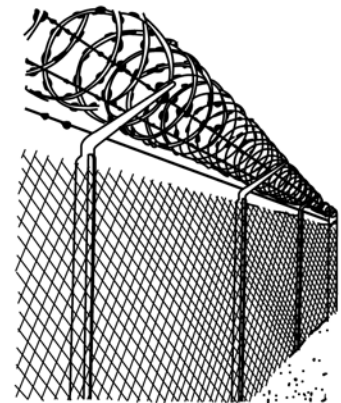

TOP OF FENCE, FOR FENCE FABRIC SHY OF 7 FEET

FIG. 10 Industrial/Commercial Installations

TABLE 1 Maximum Allowable Tolerance (Concertina)

NOTE 1—Allow up to 2 ft material loss when covering inside or outside corners.

Coil Loops Per Roll	Spacing, in. \pm 2 in.	Yield, Ln. ft	Yield, Not to Exceed \pm Ln. ft
31 (18 in. Dia)	12	15	1
31	16	20	1
31/31	16/16	20	1
51	12	25	1
56 (Type II)	21	50	1
81	12	40	1
101	12	50	1

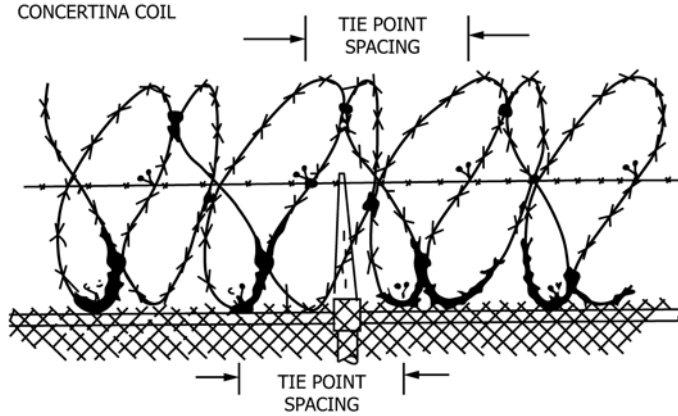

CONCERTINA SPLICE CONNECTIONS

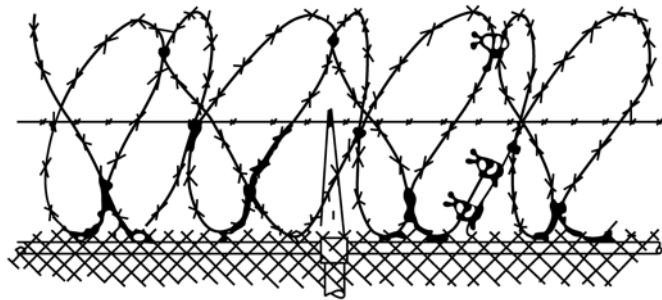

The number of connections opposite to the overlapping splice will vary depending on the number of clips.

Hog-rings or twistable tie wires are used to complete the splice.

TABLE 2 Maximum Allowable Tolerance (Helical)

NOTE 1—Allow up to 2 ft material loss when covering inside or outside corners.

Coil Loops Per Roll	Spacing, in. \pm 2 in.	Yield, Ln. ft	Yield, Not to Exceed \pm Ln. ft
33	18	50	1
33/33 (Type II)	24/24	66	+1, -3

HELICAL COIL

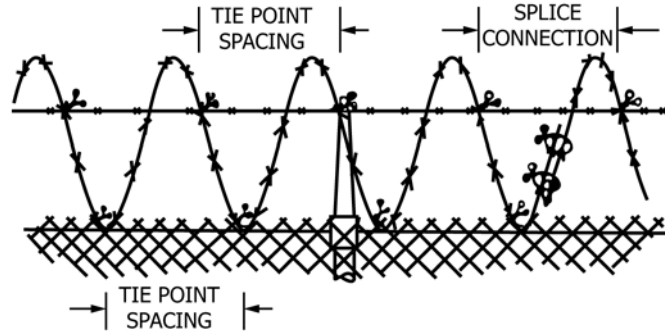

ASTM International takes no position respecting the validity of any patent rights asserted in connection with any item mentioned in this standard. Users of this standard are expressly advised that determination of the validity of any such patent rights, and the risk of infringement of such rights, are entirely their own responsibility.

This standard is subject to revision at any time by the responsible technical committee and must be reviewed every five years and if not revised, either reapproved or withdrawn. Your comments are invited either for revision of this standard or for additional standards and should be addressed to ASTM International Headquarters. Your comments will receive careful consideration at a meeting of the responsible technical committee, which you may attend. If you feel that your comments have not received a fair hearing you should make your views known to the ASTM Committee on Standards, at the address shown below.

This standard is copyrighted by ASTM International, 100 Barr Harbor Drive, PO Box C700, West Conshohocken, PA 19428-2959, United States. Individual reprints (single or multiple copies) of this standard may be obtained by contacting ASTM at the above address or at 610-832-9585 (phone), 610-832-9555 (fax), or service@astm.org (e-mail); or through the ASTM website (www.astm.org). Permission rights to photocopy the standard may also be secured from the Copyright Clearance Center, 222 Rosewood Drive, Danvers, MA 01923, Tel: (978) 646-2600; http://www.copyright.com/