



Standard Test Method for Tension and Vacuum Testing Metallized Ceramic Seals¹

This standard is issued under the fixed designation F19; the number immediately following the designation indicates the year of original adoption or, in the case of revision, the year of last revision. A number in parentheses indicates the year of last reapproval. A superscript epsilon (ϵ) indicates an editorial change since the last revision or reapproval.

1. Scope

1.1 This test method covers procedures for conducting tension and vacuum tests on metal-ceramic seals to determine the bond strength of brazed, metallized ceramics.

1.2 The values stated in inch-pound units are to be regarded as standard. The values given in parentheses are mathematical conversions to SI units that are provided for information only and are not considered standard.

1.3 *This standard does not purport to address all of the safety concerns, if any, associated with its use. It is the responsibility of the user of this standard to establish appropriate safety and health practices and determine the applicability of regulatory limitations prior to use.*

2. Referenced Documents

2.1 *ASTM Standards:*²

[E4 Practices for Force Verification of Testing Machines](#)

[E6 Terminology Relating to Methods of Mechanical Testing](#)

3. Terminology

3.1 *Definitions:*

3.1.1 The definitions of terms relating to tension testing appearing in Terminology [E6](#), shall apply to the terms used in this test method.

4. Significance and Use

4.1 This test method covers procedures for conducting tension and vacuum tests on metal-ceramic seals.

4.2 This test method is not to be considered as an absolute tension test for the ceramic.

4.3 This test method is suitable for quality control and research and development use.

¹ This test method is under the jurisdiction of ASTM Committee [F01](#) on Electronics and is the direct responsibility of Subcommittee [F01.03](#) on Metallic Materials, Wire Bonding, and Flip Chip.

Current edition approved May 1, 2016. Published May 2016. Originally approved in 1961 as F19 – 61 T. Last previous edition approved in 2011 as F19 – 11. DOI: 10.1520/F0019-11R16.

² For referenced ASTM standards, visit the ASTM website, www.astm.org, or contact ASTM Customer Service at service@astm.org. For *Annual Book of ASTM Standards* volume information, refer to the standard's Document Summary page on the ASTM website.

5. Apparatus

5.1 *Testing Machines*—Machines used for tension testing shall conform to the requirements of Methods [E4](#). Only loads that are within the loading range of the testing machine, as defined in Methods [E4](#), shall be used for determining tensile strengths.

5.2 *Gripping Devices*—Various types of gripping devices may be used to apply the load to the test specimen. Those shown in [Fig. 1](#) are recommended, but regardless of which grips are used, care shall be taken that the axis of the test specimen is in alignment with the centerline of the test machine heads.

6. Preparation of Specimens

6.1 Prepare the test specimen by brazing together two pieces of ceramic, shown in [Fig. 2](#), at their respective metallized surfaces, as described in [6.1.1](#) to [6.1.3](#):

6.1.1 *Ceramics*—Grind the test surface, A, ([Fig. 2](#)) of the two ceramic parts flat to within 0.00025 in. (0.0064 mm) according to good grinding practice using an abrasive passing or finer than a No. 100 (150- μ m) sieve. The ground surface, A, of each part shall be parallel to shoulder C, as shown in [Fig. 2](#), consistent with the best commercial practice. The over-all appearance of each ceramic half of the test specimen shall indicate good commercial practice, and shall be free from obvious defects. In the results of the test, report the method of manufacture of the specimen components, that is, slip cast, hotpressed, hydrostatically molded, etc. Measure and record the test surface area of each ceramic half on a projection comparator, or by other suitable means. Dye check the two ceramic parts and inspect them for flaws ([Note 1](#)). Reject all parts showing flaws considered conducive to abnormal failures of either ceramic part.

NOTE 1—A suggested dye check procedure is described in the Appendix.

6.1.2 *Metallized Coating*—Metallize the specimen halves under identical conditions, that is, temperature, atmosphere, etc. The type of metallizing used is optional, or as mutually agreed upon between producer and consumer. Apply the metallizing coating only to the test surface A, [Fig. 2](#), on the specimen. The method of metallizing is optional, that is, silk screen, brush, spray, roller, etc., but should be reported.

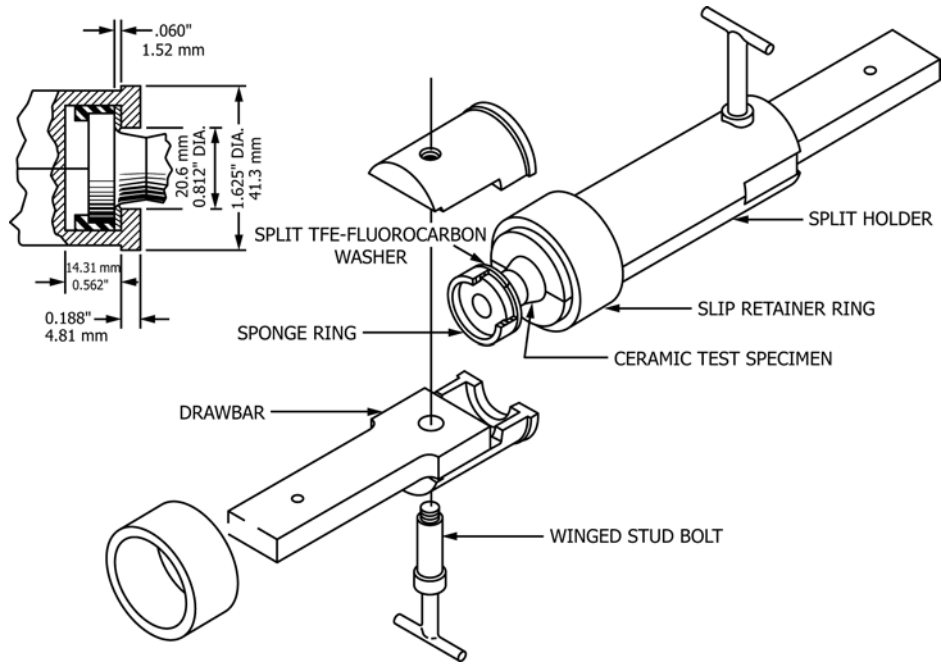

NOTE 1—Tolerance on all dimensions shown, ± 0.016 in. (0.41 mm).

FIG. 1 Self Aligning Grip for Tension Test

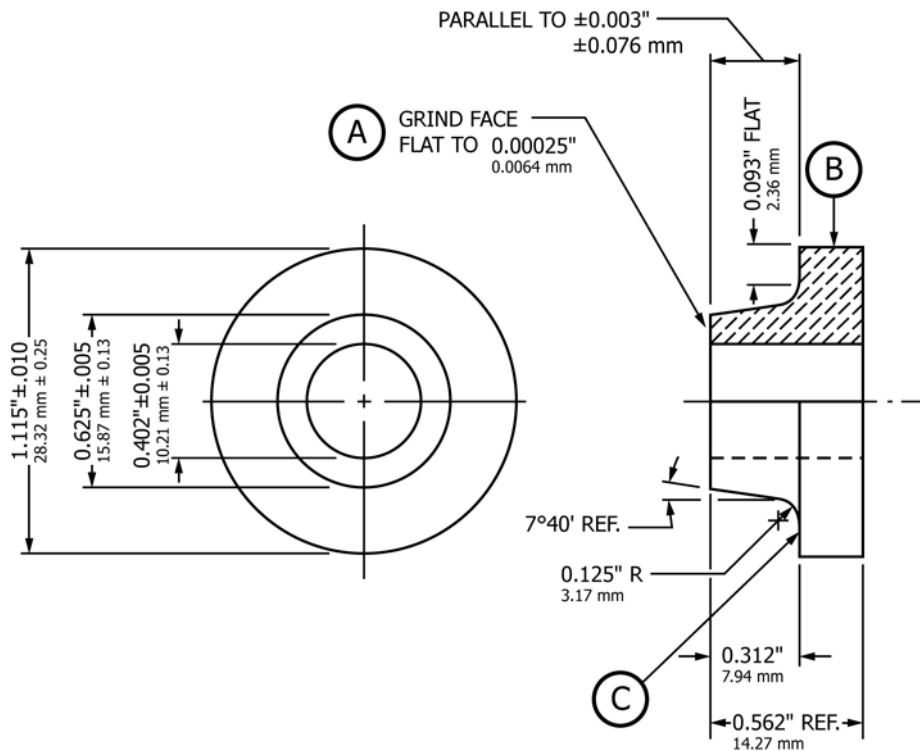

- A—Seal surface area to be metallized.
- B—Surface inscribed with date as to ceramic batch and firing temperature.
- C—Gripping shoulder.

FIG. 2 Ceramic Half of Tension Test Specimen

NOTE 2—A typical metallizing procedure is described in the Appendix.

6.1.3 *Assembling the Test Specimen*—Place the two mating parts in a suitable jig to achieve axial alignment of the mated ceramic halves and alignment of the metallized surfaces. Accurate alignment, which is essential to attain uniform test results, may be accomplished by jiggling with a rod of refractory material, such as ceramic or carbon (Fig. 3). Pass the rod through the assembly and then braze the specimen in a vertical position. In the test results, report the brazing material used; such as copper-silver eutectic, copper-gold alloy, 35 to 65 %, etc. Use sufficient material to produce an even fillet at the joint. Load the assembly to produce pressure on the seal during the brazing operation and report the weight of the load.

7. Procedure

7.1 *Leak Test*—The brazed test specimen may be vacuum-leak checked on any conventional helium spectrometer-type leak checker with a sensitivity of 5×10^{-9} cc/s at (5×10^{-9} mL/s) at standard temperature and pressure. Subject the specimen continuously to an atmosphere of helium for 1/2 to 5 min. The leak-checking instrument, set at maximum sensitivity, shall show no indication of a leak during the test period.

7.2 *Tension Test*— Place the specimen in the self-aligning grips with a polytetrafluoroethylene (TFE-fluorocarbon) washer between the ceramic and the jaws of the grip (see Fig. 1). Test all specimens under the same loading rate which, although optional, shall be reported.

7.3 *Other Tests*— Brazed assemblies prepared in accordance with Section 5 can also be used to:

7.3.1 Test ceramic-metal seals with a metal washer inserted between the test pieces, and

7.3.2 Perform environmental tests such as heat shock, oxidation resistance, and bakeout, to determine either the point of vacuum failure or the tensile strength at vacuum failure.

8. Calculation

8.1 Calculate the tensile strength by dividing the maximum load on the specimen during the tension test by the original cross-sectional area. Consider only those specimens that break in or near the seal area when calculating test data. Fracture of the test specimen in any other area than at or adjacent to the seal may indicate either a lack of alignment of the ceramic parts or a bond strength exceeding the range of the test specimen.

9. Report

- 9.1 Report the following information:
 - 9.1.1 Method of manufacture of the specimen components,
 - 9.1.2 Test surface area of each specimen component,
 - 9.1.3 Method of metallizing specimen,
 - 9.1.4 Brazing material used,
 - 9.1.5 Load applied to specimen during brazing,
 - 9.1.6 Results of leak test,
 - 9.1.7 Loading rate of tension test,
 - 9.1.8 Tensile strength in pounds per square inch, and
 - 9.1.9 Results of other tests performed in addition to leak and tension tests.

10. Precision and Bias

10.1 *Precision*—It is not possible to specify the precision of Test Method F19 for measuring the tensile strength or leak rate of metallized ceramic seals because an interlaboratory study utilizing these methods has not been conducted.

10.2 *Bias*—No information can be presented on the bias of the procedures in Test Method F19 for measuring tensile strength or leak rate of metallized ceramic seals because no specimens having an accepted reference value (traceable to a national standards laboratory) are available.

11. Keywords

11.1 brazing; leak rate test; metallized ceramic seals; tension testing

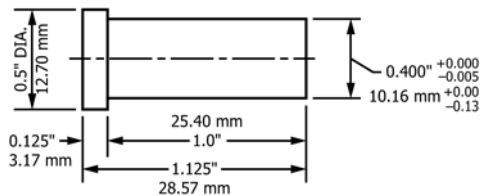

NOTE 1—Material—ACX Graphite.

FIG. 3 Alignment Jig for Brazing Tension Test Specimen

APPENDIX

(Nonmandatory Information)

X1. TYPICAL METALLIZING PROCEDURE

X1.1 Scope

X1.1.1 This procedure is intended to serve as a guide for those not familiar with ceramic metallizing techniques. It is not intended as a recommended procedure.

X1.2 Summary of Method

X1.2.1 This procedure for metallizing the ceramic specimens is covered in five essential steps as follows:

X1.2.1.1 Dye check,

- X1.2.1.2 Clean,
- X1.2.1.3 Paint,
- X1.2.1.4 Fire, and
- X1.2.1.5 Plate.

X1.3 Dye Check

X1.3.1 Dye check the test specimen parts to bring out flaws such as chips or cracks in the ceramic in the following manner:

X1.3.1.1 Soak the test specimen in dye.

NOTE X1.1—A satisfactory dye is Rhodamine B, 50 % concentrated solution, diluted to 30 mL/L with methyl alcohol.

X1.3.1.2 Rinse the specimen in methyl alcohol until the dye is removed, and allow it to dry.

X1.3.2 Inspect the specimen for flaws.

X1.3.2.1 Visible cracks on the test specimen are cause for rejection.

X1.3.2.2 Chips in areas other than the seal area are permissible.

X1.3.2.3 Excessive retention of dye, indicating high porosity of the ceramic is cause for rejection.

X1.4 Cleaning of Ceramics to Be Metalized

X1.4.1 The specimen shall be free of all oils and greases and the seal surface free of contamination from metallic particles or smears when cleaned in the following manner:

X1.4.1.1 Soak the specimen in a hot solution of any good detergent for ½ h, then rinse in deionized water.

X1.4.1.2 Soak the specimen for 5 min in hot (approximately 65°C) dilute (1 + 1) solution of nitric acid (HNO₃), technical grade, and water. Rinse the specimen in hot (approximately 80°C) deionized water, and oven dry.

X1.5 Application of Metalizing Coating

X1.5.1 Paint the seal surface of the ceramic, using a suitable brush, with the (typical) mixture shown in Table X1.1.

X1.5.2 Mix the components in a 1-qt. (1-L) ball mill, and grind with alumina balls for 100 h.

X1.5.3 Mount the specimen on a slowly rotating fixture. Dip the brush in the well-stirred mixture and apply a smooth, continuous, uniform coat to the ceramic. Use sufficient mixture

on the brush to cover the surface to be coated in one operation. Keep the paint well stirred while painting. After painting air dry the specimen.

X1.6 Firing

X1.6.1 Fire the coated specimen in a furnace capable of sustaining 1500°C continuous operation. The atmosphere in which the part is fired should be strongly reducing but with a sufficiently high dew point to prevent reduction of the ceramic.

X1.6.2 Fire the specimen for 30 min at 1500 to 1525°C in hydrogen, bubbled through water to attain the proper humidity. Cool the specimen in hydrogen at the recommended rate prescribed in X1.6.3.

X1.6.3 Recommended rates of heating and cooling are shown in Table X1.2.

X1.7 Plating

X1.7.1 To facilitate brazing with commercially available alloys, plate the metalized specimens to a thickness of 0.013 mm with nickel. A suitable plating bath (Note X1.2) is as follows:

Material	Quantity
Nickel chloride (NiCl ₂)	300 g/L
Boric acid (H ₃ BO ₃)	30 g/L
pH ^A	3.0

^A Adjust the pH with pure hydrochloric acid (HCl).

NOTE X1.2—Use pure nickel anodes. Operate the bath at 60°C (approximate).

X1.7.2 Mount the specimen on a rack and make contact with the seal area. Plate the part at 60 A/ft² (5.5 A/m²), for 10 min. Rinse the specimen in deionized water, then rinse in acetone, and air dry.

TABLE X1.1 Typical Metallization Coating Mixture

Material	Quantity
Molybdenum metal powder, fine, passing No. 200 (75-µm) sieve, g	200
Manganese metal powder, fine, passing No. 200 (75-µm) sieve, g	50
Ethylcellulose, g	5
Methyl amyl acetate, mL	65
Methyl ethyl ketone, mL	45
Ethylene glycol monoethyl ether (Cellosolve), mL	85
Acetone, mL	90

TABLE X1.2 Typical Heating and Cooling Rates

Temperature Range	Time
Heating	
20 to 600°C	15 min
600 to 1200°C	30 min
1200 to 1500°C	15 min
Cooling:	
1500 to 1000°C	5 min
1000 to room temperature (C)	60 min

ASTM International takes no position respecting the validity of any patent rights asserted in connection with any item mentioned in this standard. Users of this standard are expressly advised that determination of the validity of any such patent rights, and the risk of infringement of such rights, are entirely their own responsibility.

This standard is subject to revision at any time by the responsible technical committee and must be reviewed every five years and if not revised, either reapproved or withdrawn. Your comments are invited either for revision of this standard or for additional standards and should be addressed to ASTM International Headquarters. Your comments will receive careful consideration at a meeting of the responsible technical committee, which you may attend. If you feel that your comments have not received a fair hearing you should make your views known to the ASTM Committee on Standards, at the address shown below.

This standard is copyrighted by ASTM International, 100 Barr Harbor Drive, PO Box C700, West Conshohocken, PA 19428-2959, United States. Individual reprints (single or multiple copies) of this standard may be obtained by contacting ASTM at the above address or at 610-832-9585 (phone), 610-832-9555 (fax), or service@astm.org (e-mail); or through the ASTM website (www.astm.org). Permission rights to photocopy the standard may also be secured from the Copyright Clearance Center, 222 Rosewood Drive, Danvers, MA 01923, Tel: (978) 646-2600; http://www.copyright.com/