



Standard Specification for Residential Basketball Systems¹

This standard is issued under the fixed designation F1882; the number immediately following the designation indicates the year of original adoption or, in the case of revision, the year of last revision. A number in parentheses indicates the year of last reapproval. A superscript epsilon (ϵ) indicates an editorial change since the last revision or reapproval.

1. Scope

1.1 This specification covers the manufacture, assembly, recommended maintenance and use of complete residential basketball systems.

1.2 This specification is intended to reduce the potential hazards associated with the installation and use of residential basketball systems.

1.3 This specification is not intended to apply to the following:

1.3.1 Equipment intended to be used in places of public assembly, such as, but not limited to, schools, parks, public and private recreational facilities.

1.3.2 Individual components, such as rim, backboard, pole, portable base system, net, or other component when that component is not sold as a complete residential basketball system as defined in this specification.

1.3.3 Any residential basketball system that is mounted to any structure or surface other than that which is purchased as part of a complete residential basketball system. Examples include, but are not limited to, roof mounting, wall mounting, or any locally or self-manufactured components.

1.3.4 Any basketball equipment that does not use a full size rim, 18-in. (45.72-cm) diameter, or is designed for operational heights of less than 6 ft 6 in. (1.98 m) from the playing surface to the bottom of the backboard.

1.3.5 Accessories and add-ons.

1.4 This specification shall apply only to products manufactured after twelve months from the date this specification is published.

1.5 This specification does not cover product performance or quality, except as related to safety.

1.6 The rationale for provisions in this specification are given in [Appendix X1](#) and [Appendix X2](#).

1.7 The values stated in inch-pound units are to be regarded as standard. The values given in parentheses are mathematical

conversions to SI units that are provided for information only and are not considered standard.

1.8 *This standard does not purport to address all of the safety concerns, if any, associated with its use. It is the responsibility of the user of this standard to establish appropriate safety and health practices and determine the applicability of regulatory limitations prior to use.*

2. Referenced Documents

2.1 *ASTM Standards:*²

[D2240 Test Method for Rubber Property—Durometer Hardness](#)

[C1048 Specification for Heat-Strengthened and Fully Tempered Flat Glass](#)

[F1148 Consumer Safety Performance Specification for Home Playground Equipment](#)

2.2 *ANSI Standards:*³

[ANSI Z535 Warning Labels](#)

[ANSI Z97.1–2004 American National Standard for Safety Glazing Materials Used in Buildings—Safety Performance Specification and Methods of Test](#)

2.3 *BSI Standard:*⁴

[BSI 6206: 1981 Impact Performance Requirements for Flat Safety Glass and Safety Plastics for Use in Buildings](#)

2.4 *Federal Standards:* Available from the Consumer Product Safety Commission, Washington, DC 20207.

[16 CFR 1303 Ban of Lead-Containing Paint and Certain Consumer Products Bearing Lead-Containing Paint](#)

[16 CFR 1500.48 Technical Requirements for Determining a Sharp Point in Toys and Other Articles Intended for Use by Children Under 8-Years of Age](#)

[16 CFR 1500.49 Technical Requirements for Determining a Sharp Metal or Glass Edge in Toys and Other Articles Intended for Use by Children Under 8-Years of Age](#)

² For referenced ASTM standards, visit the ASTM website, www.astm.org, or contact ASTM Customer Service at service@astm.org. For *Annual Book of ASTM Standards* volume information, refer to the standard's Document Summary page on the ASTM website.

³ Available from National Electrical Manufacturers Association (NEMA), 1300 N. 17th St., Suite 1847, Rosslyn, VA 22209.

⁴ Available from British Standards Institute (BSI), 389 Chiswick High Rd., London W4 4AL, U.K.

¹ This specification is under the jurisdiction of ASTM Committee F08 on Sports Equipment, Playing Surfaces, and Facilities and is the direct responsibility of [F08.25](#) on Recreational Basketball Equipment.

Current edition approved June 1, 2015. Published August 2015. Originally approved in 1998. Last previous edition approved in 2014 as F1882 – 06 (2014). DOI: 10.1520/F1882-15.

3. Terminology

3.1 *Definitions of Terms Specific to This Standard:*

3.1.1 *accessories and add-ons (items not covered in 3.1.2, 3.1.3, 3.1.5, 3.1.6, 3.1.10, and 3.1.15–3.1.18), n*—including but not limited to, such things as pole pads, ball returns, scoring and training devices, and including items attached to the system not intended for use in basketball.

3.1.2 *adjusting mechanism, n*—moveable components that lock structural components in the desired position to facilitate changes in rim height.

3.1.3 *backboard, n*—rigid, flat surface to provide rebound surface for a basketball.

3.1.4 *complete residential basketball system, n*—any combination of rim, net, backboard, portable or non-portable pole-type support system not specifically excluded in 1.3.1 – 1.3.5 that is designed and marketed by the original manufacturer to be used together, whether packaged together as a system, or separately as individual components.

3.1.5 *footing, n*—the method for securing the placement of the system into the ground.

3.1.6 *full-size rim, n*—moveable or fixed-type rim with an 18-in. (45.72-cm) inside diameter.

3.1.7 *ground base systems, n*—systems that have a main support pole attached in ground by a footing.

3.1.8 *hanging, v*—when a player briefly suspends their full weight from any point on the rim.

3.1.9 *maximum offset, n*—distance from the front of the base or pole, whichever extends furthest from the system, to the front face of the backboard.

3.1.10 *net, n*—a device that hangs below the rim that restricts the downward movement of the ball.

3.1.11 *normal access area, n*—as described in Fig. 1.

3.1.12 *normal use, n*—those safe-play modes that conform to the instructions that accompany the equipment. Misuse, alteration, or modification are not considered normal use.

3.1.13 *pinch, crush, shear points, n*—any point that entraps at one or more positions a ½-in. (13-mm) diameter neoprene rod. Entrapment shall mean that force of more than 2 lb (0.90 kg) is required to pull out the rod. The neoprene rods shall have a hardness reading between 50 and 60 as determined by a Type A Durometer as given in Test Method D2240.

3.1.14 *pole joint, n*—mechanical method for connecting a multiple segment pole.

3.1.15 *portable base systems, n*—systems that have a ballast type support system that allows the system to be moved.

3.1.16 *residential basketball equipment, n*—equipment that is intended for the normal use and play in residential basketball that includes the components given in 3.1.3, 3.1.6, 3.1.10, and 3.1.18.

3.1.17 *supplemental restraint systems, n*—additional methods of adding stability over and above recommended ballast to portable base systems, that is ground stakes and additional weight.

3.1.18 *support system, n*—structure provided to support rim and backboard in playing position. Could include pole, portable base, or mounting brackets.

4. General Requirements

4.1 A complete residential basketball system, represented as complying with this performance specification, shall meet all applicable requirements specified herein.

5. Performance Requirements

5.1 *General*—The standards listed in 5.3 – 5.6 apply only to the normal access area as described in 3.1.11 and Fig. 1.

5.2 *Paint Toxicity*—All paints and finishes used on basketball equipment shall be in accordance with 16 CFR Part 1303.

5.3 *Edges, Points, and Surfaces*—Following assembly of the system, in accordance with the instructions to be provided to the consumer, there shall be no exposed sharp edges, points, or surfaces on any portion of the residential basketball equipment according to CPSC 16 CFR 1500.48 and 1500.49.

5.4 There shall be no pinch, crush, or shear points as defined in 3.1.13.

5.5 Moving parts or height adjustment mechanisms outside the normal access area, which could pose a finger entrapment problem, shall be noted clearly in the warning label on the system and the safety instructions for proper use to reduce the risk of injury.

5.6 *Hardware*—Hardware must comply with the section on Hardware, Nuts, and Bolts of Performance Specification F1148.

5.6.1 An projections and protrusions must comply with CPSC Handbook for Playground Safety Publication 325 and Performance Specification F1148.

5.6.2 Lock washers, self-locking nuts, or other locking means shall be provided for all permanently attached bolts.

5.7 *Rims:*

5.7.1 *Rims*—Each rim shall be attached to a support structure in such a way that ensures the rim and all structural components stay attached should the backboard break.

5.7.2 *Backboards Made of Glass*—All glass backboards shall be made of fully tempered glass. As specified in Specification C1048, “Fully tempered glass is approximately four times as strong as annealed glass of the same thickness and configuration. When broken, by impact, fully tempered glass fractures into relatively small pieces meeting safety glazing requirements thereby greatly reducing the likelihood of serious cutting or piercing injuries in comparison with ordinary annealed glass. Fully tempered glass is intended for used in applications where its strength or safety characteristics may be required.” The very nature of basketball makes it obvious that the increased strength and safety characteristics of fully tempered glass should be required in any glass backboard application.

6. Stability/Structural Integrity

6.1 *Portable Base System Testing (To Be Performed by the Manufacturer)*—The test should be performed to determine the

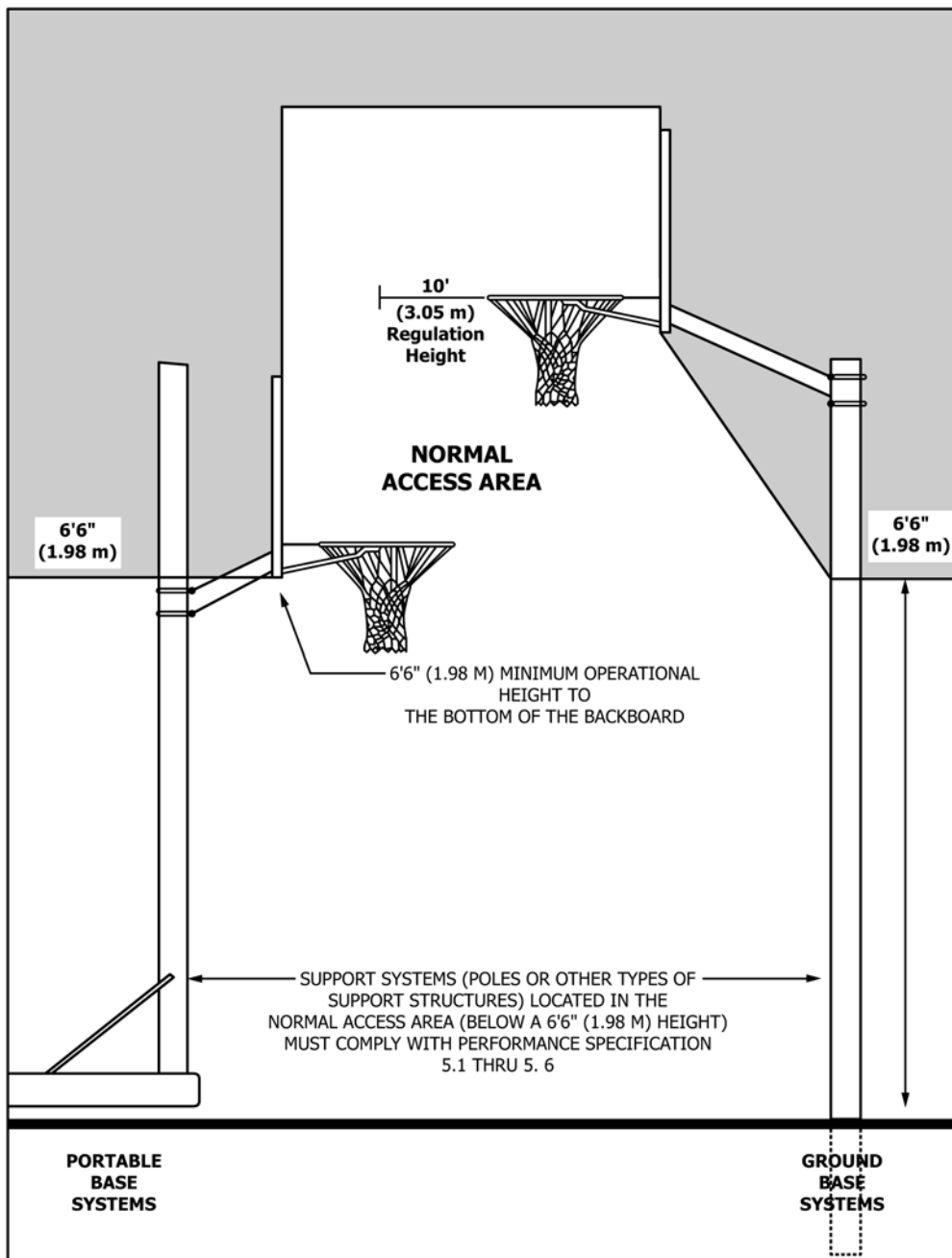

FIG. 1 Normal Access Area

ability of the portable base system to withstand anticipated forces which act to tip, slide, or cause permanent deformation, or a combination thereof, to the system. Complete assembly/installation according to manufacturer's recommendations. The force for all tests shall be applied gradually within a period of 1 min and maintained for a period of 5 min. All tests are to be performed at a room temperature of $68 \pm 5^\circ\text{F}$ ($22 \pm 15^\circ\text{C}$). This test must be performed with rim at 10-ft (3.05-m) regulation height and through its entire recommended adjustment range. The system must be tested without additional supplemental restraint systems. After conducting the tests, there shall be no visible cracks, permanent deformation,

breakage, or deterioration of any component that may adversely affect the structural integrity or safety of the equipment.

6.1.1 *Horizontal Testing* (Fig. 2)—To simulate a 40-mph (64.4-kph) wind force, calculate the square footage of the backboard and refer to Fig. 3 to determine the horizontal load required to replicate the wind force. For Test No. 1, apply this horizontal load as shown in Fig. 2. If the rim height at the point of load application drops more than 6 in. (15.24 cm), stop the test and reposition the pulley. Proceed to Test No. 2. For Test No. 2, if required, with pulley realigned 6 in. (15.2 cm) lower, reapply horizontal test load and check if rim height drops more

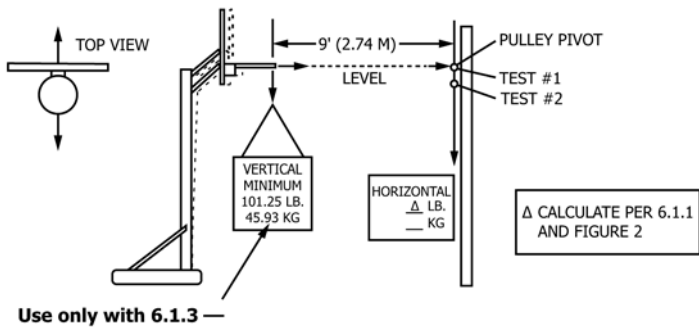

FIG. 2 Portable Base Horizontal and Vertical Testing

than 6 in. (15.24 cm). If so, repeat in 6-in. (15.14-cm) pulley height reduction segments. The test must be performed in both forward and rearward directions, and the system must not tip over beyond the balance point, in accordance with Fig. 4.

6.1.2 *Horizontal Rim Weight (Fig. 5)*—Determine the weight of the system (at the rim) while in a level horizontal position 80 lb (36.39 kg) max.

6.1.3 *Vertical Minimum Load (Fig. 2)*—This load is 101.25 lb (45.93 kg), and it must be applied vertically from the tip of the rim. With the required load, system must not tip over past its balance point in accordance with Fig. 4.

6.1.4 *Balance Point of System Testing (Fig. 4)*—Pull system forward to the point of balance where it will not fall forward or backward. The maximum distance between the tip of rim and the ground should be less than 5 ft 6 in. (1.68 m). When the system is released above the natural balance point, it must return system to the normal upright position.

6.1.5 *Horizontal Side Testing (Fig. 6)*—With a 25-lb (11.34-kg) load, the portable system must not tip over sideways to such a point where the rim/backboard touches the ground. Follow the test method described in 6.1.1.

6.1.6 *Portability Test on an Incline (Fig. 7)*—When following manufacturer’s recommendations for moving the portable system, the system must remain in its transport (movable) position when placed on a 5° slope in any direction.

6.1.7 When following the manufacturer’s recommendations for moving the portable system, the system must be capable of being moved a distance of 50 ft (15.24 m).

6.2 *Ground Base System Testing (to be performed by the manufacturer)*—The test should be performed to determine the ability of the ground base system to withstand anticipated forces which act to tip, slide, or cause permanent deformation, or a combination thereof, to the system. Complete assembly/installation according to manufacturer’s recommendations. The force for all tests shall be applied gradually within a period of 1 min and maintained for a period of 5 min. This test must be performed with rim at 10-ft (3.05-m) regulation height and through its entire recommended adjustment range. After conducting the tests, there shall be no visible cracks, permanent deformation, breakage or deterioration of any component that may adversely affect the structural integrity or safety of the equipment.

6.2.1 *Horizontal Testing (Fig. 8)*—To simulate a 80-mph (128.8-kph) wind force, calculate the square footage of backboard and refer to Fig. 3 to determine the horizontal load

required to replicate the wind force. For Test No. 1, apply this horizontal load in accordance with Fig. 8. If the rim height drops more than 6 in. (15.24 cm) stop test and reposition pulley. Proceed to Test No. 2. For Test No. 2, if required, with the pulley realigned 6 in. (15.24 cm) lower, reapply horizontal test load and check if rim height drops more than 6 in. (15.24 cm). If so, repeat in 6 in. (15.24 cm) pulley height reduction segments. The test must be performed in both a forward and rearward directions.

6.2.2 *Vertical Testing (Fig. 8)*—Apply a 250-lb (113.4-kg) load at the tip of the rim.

6.2.3 Glass backboards shall be tested in accordance with BS 6206:1981 Appendix B Parts B.3 and B.4.

6.2.3.1 *App. B Part B.3*—“Apparatus—The following apparatus is required. *B.3.1 Impactor*, with a radius of curvature of the point of 0.20 mm = 0.05 mm. *NOTE*—A pointed hammer of at least 75 g mass, or a spring loaded centre punch or similar appliance can be used. *B.3.2 Means of support*, comprising a flat base on which the test piece is laid without any mechanical constraint. In order to prevent scattering of fragments, the test piece shall be simply held at the edges so that the fragments remain interlocked after breakage, without hindering extension of the test piece.”

6.2.3.2 *App. B Part B.4*—“Procedure—Strike the test piece 13 mm from its longest edge at the midpoint of that edge until breakage occurs.”

6.2.3.3 Once breakage occurs, the results shall be interpreted in accordance with ANSI Z97.1, Section 5.1.4 (2): “A glazing material shall be judged to pass the impact test, if when breakage occurs, the ten largest crack-free particles shall be selected within 5 min subsequent to the impact and shall weigh no more than the equivalent weight of 10 in.² (640 mm²) of the original specimen. For purposes of impact test evaluation when breakage occurs, the average thickness of a tempered glass specimen containing grooves, bevels, or other thickness altering fabrication shall be considered the average of the thinnest measurement of each of the ten geometrically largest crack-free particles. This average thickness will then be used to determine the maximum allowable weight of the ten largest crack-free particles.”

7. Warning Labels

7.1 Labels shall be attached permanently to the product in an obvious location visible to player, or operator, or both. The addition of warnings or deletion of inapplicable warnings for specific requirements are at the discretion of the manufacturer. The warning labels shall comply with ANSI Z535 on labeling for color, text, positioning, etc. See Fig. 9 and Fig. 10. The labels shown in these figures represents the minimum warnings required.

8. Instructions

8.1 Each basketball system shall be accompanied by instructions that are marked clearly. The safety instructions shown in Fig. 11 and Fig. 12 define the standard. Slight customization to specific requirements of each manufacturer will be allowed. The addition of safety instructions or deletion of inapplicable safety instructions for specific requirements are at the discretion of the manufacturer.

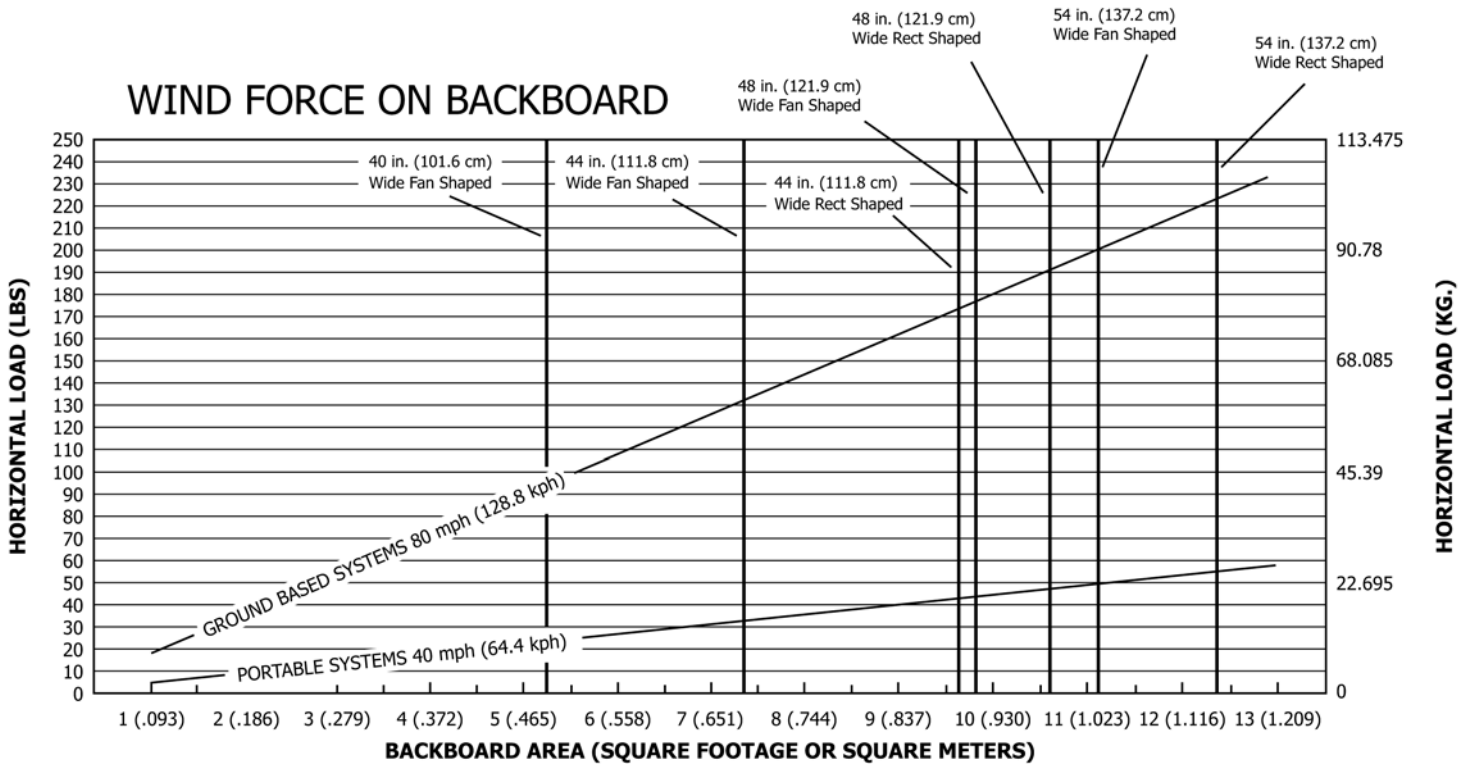

- Assumptions:
- 1) Normal properties of air at sea level.
 - 2) Wind force acting on centroid of backboard area.
 - 3) Backboard surface is perpendicular to airflow.
 - 4) Backboard sizes indicated are approximate. Calculate exact backboard area using the actual dimensions of the backboard being tested.
 - 5) Load at rim assumes centroid is located 10% higher.

NOTE 1—The backboard sizes listed are for comparison use only. Each manufacturer is responsible for calculating and documenting the size of then backboard being tested.

FIG. 3 Wind Force on Backboard

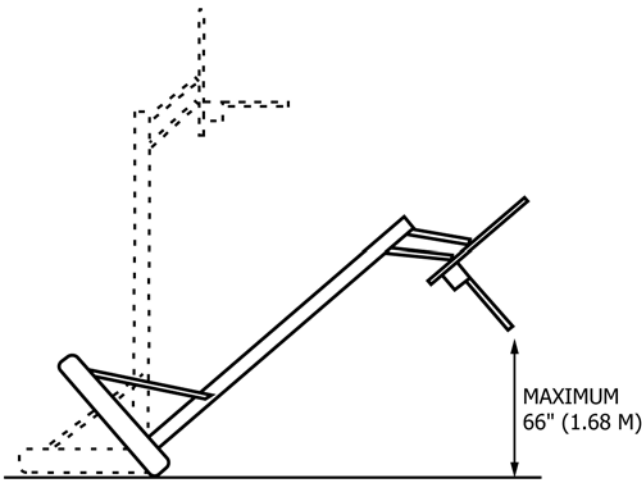

FIG. 4 Portable Base Balance Point of System Testing

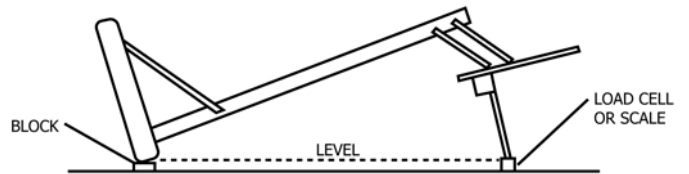

FIG. 5 Portable Base Horizontal Rim Weight Determination

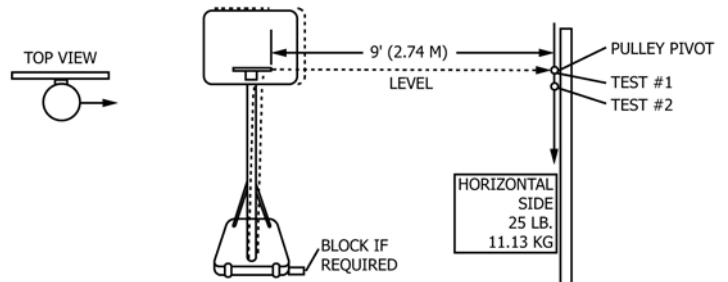

FIG. 6 Portable Base Horizontal Side Testing

8.2 *Assembly/Installation Instructions*—The manufacturer’s assembly instructions for the basketball system shall be written and presented clearly so that it can be assembled and installed properly and safely. Detailed information must be provided for safe installation and use of the product.

8.3 All warning labels on the product must be duplicated in the instructions. The following additional warnings must also

appear in the instructions. Fig. 11 illustrates safety instructions for portable base systems with height adjustment. Fig. 12 illustrates safety instructions for ground base systems.

8.4 *Parts Lists*—Diagrams of bolts, nuts, and washers, and a list and description of all tools and materials required shall be

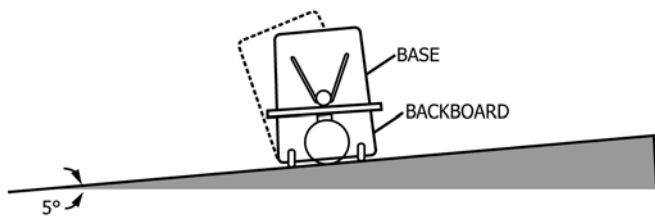

FIG. 7 Portability Test on an Incline

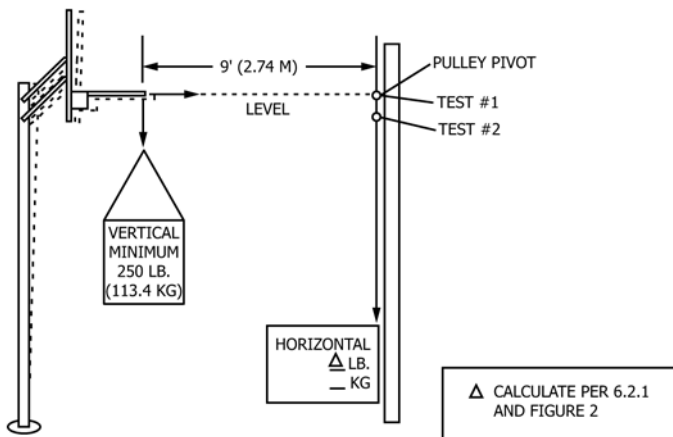

FIG. 8 Ground Base Horizontal and Vertical Testing

incorporated into the instructions. Lock nuts shall be identified clearly. Cautionary statements that recommend tightening bolts securely shall be included.

8.5 *Information on Manufacturer*—The instructions shall include in a prominent place, the name and method of contacting the manufacturer, and the model number of the product. There shall be an instruction to the buyer to “Save this instruction in the event that the manufacturer has to be contacted for replacement parts.”

8.6 Each manufacturer shall instruct (with use of graphics affixed permanently to the system) how to safely move the portable system.

9. Packaging

9.1 All equipment shall be packaged in a manner that will preclude any sharp edges from being exposed during normal transit or storage.

! **WARNING** !

FAILURE TO FOLLOW THESE WARNINGS MAY RESULT IN SERIOUS INJURY AND/OR PROPERTY DAMAGE

Owner must ensure that all players know and follow these rules for safe operation of the system.

- Only hang from the rim briefly to regain balance or avoid injuring others. Release the rim as soon as safely possible.
- During play, especially when performing dunk type activities, keep players face away from the backboard, rim, and net. Serious injury could occur if teeth/face come in contact with backboard, rim, or net.
- Do not slide, climb, or play on base or pole.
- Completely fill base according to manufacturers instructions or the system will tip quickly causing serious personal injury.
- When adjusting height or moving system, keep hands and fingers away from moving parts.
- Do not allow children to move or adjust system.
- During play, do not wear jewelry (rings, watches, necklaces, etc.). Objects may entangle in net.
- Surface beneath the base must be smooth and free of gravel or other objects. Punctures can cause leakage and could cause system to tip over.
- Keep water and organic material away from pole. Pole can rust and fall.
- Once a month check pole and all metal parts for rust. Completely remove rust and repaint with exterior enamel. If rust has penetrated any steel part, replace that part immediately.
- Check system before each use for proper ballast, loose hardware, instability, and signs of corrosion and repair before each use. Never play on damaged equipment.
- Do not use system during windy or severe weather. System may tip over. Place system in an area protected from the wind or in an area away from property that may be damaged if the system falls.

COMPANY NAME

1-8XX-XXX-XXXX

FIG. 9 Warning Label for Portable Base Systems

10. Keywords

10.1 backboard; basketball; goal; hoop; portable; residential; rim; safety; specification; standard

! **WARNING** !

FAILURE TO FOLLOW THESE WARNINGS MAY RESULT IN SERIOUS INJURY AND/OR PROPERTY DAMAGE

Owner must ensure that all players know and follow these rules for safe operation of the system.

- Only hang from the rim briefly to regain balance or avoid injuring others. Release the rim as soon as safely possible.
- During play, especially when performing dunk type activities, keep players face away from the backboard, rim, and net. Serious injury could occur if teeth/face come in contact with backboard, rim, or net.
- Do not slide, climb, or play on pole.
- When adjusting height or moving system, keep hands and fingers away from moving parts.
- Do not allow children to move or adjust system.
- During play, do not wear jewelry (rings, watches, necklaces, etc.). Objects may entangle in net.
- Keep water and organic material away from pole. Pole can rust and fall.
- Once a month check pole and all metal parts for rust. Completely remove rust and repaint with exterior enamel. If rust has penetrated any steel part, replace that part immediately.
- Check system before each use for loose hardware, signs of rust and instability. Repair before each use. Never play on damaged equipment.

COMPANY NAME

1-8XX-XXX-XXXX

FIG. 10 Warning Label for Ground Base Systems

! **SAFETY INSTRUCTIONS** !

FAILURE TO FOLLOW THESE SAFETY INSTRUCTIONS MAY RESULT IN SERIOUS INJURY OR PROPERTY DAMAGE AND WILL VOID WARRANTY.

Owner must ensure that all players know and follow these rules for safe operation of the system.

To ensure safety, do not attempt to assemble this system without following the instructions carefully. Check entire box and inside all packing material for parts and/or additional instruction material. Before beginning assembly, read the instructions and identify parts using the hardware identifier and parts list in this document. Proper and complete assembly, use, and supervision are essential for proper operation and to reduce the risk of accident or injury. A high probability of serious injury exists if this system is not installed, maintained, and operated properly.

- If using a ladder during assembly, use extreme caution.
- * capable adults are recommended for this operation.
- Check base daily for leakage. Leaks will cause system to fall.
- Assemble the pole sections properly (if applicable). Failure to do so could cause the pole sections to separate during play or transport.
- Minimum operational height is 6'6" (1.98 m) to the bottom of backboard.

*Most injuries are caused by misuse and/or not following instructions.
Use caution when using this system.*

* Number of people recommended is at the manufacturer's discretion

FIG. 11 Safety Instructions for Portable Base Systems

| |
|---|
| <div style="display: flex; justify-content: space-between;"> ⚠ <h2 style="margin: 0;">SAFETY INSTRUCTIONS</h2> ⚠ </div> |
| <p>FAILURE TO FOLLOW THESE SAFETY INSTRUCTIONS MAY RESULT IN SERIOUS INJURY OR PROPERTY DAMAGE AND WILL VOID WARRANTY.</p> <p><i>Owner must ensure that all players know and follow these rules for safe operation of the system.</i></p> <p>To ensure safety, do not attempt to assemble this system without following the instructions carefully. Check entire box and inside all packing material for parts and/or additional instruction material. Before beginning assembly, read the instructions and identify parts using the hardware identifier and parts list in this document. Proper and complete assembly, use, and supervision are essential for proper operation and to reduce the risk of accident or injury. A high probability of serious injury exists if this system is not installed, maintained, and operated properly.</p> |
| <ul style="list-style-type: none"> • If using a ladder during assembly, use extreme caution. • * capable adults are recommended for this operation. • Assemble the pole sections properly (if applicable). Failure to do so could cause the pole sections to separate during play or transport. • Before digging, contact utility company to locate underground power cables, gas, and water lines. Ensure that there are no overhead power lines within 20 ft. (7 m) radius of pole location. • Minimum operational height is 6'6" (1.98 m) to the bottom of backboard. |
| <p><i>Most injuries are caused by misuse and/or not following instructions. Use caution when using this system.</i></p> |

* Number of people recommended is at the manufacturer's discretion

FIG. 12 Safety Instructions for Ground Base Systems

APPENDIXES

(Nonmandatory Information)

X1. RATIONALE FOR SAFETY SPECIFICATIONS FOR RESIDENTIAL BASKETBALL SYSTEMS

X1.1 *Introduction* —It was determined by the major manufacturers of residential basketball equipment that a safety standard was needed for the industry because of the following factors:

X1.2 The sport of basketball has changed in recent years due to increased slam dunking and the evolution of adjustable systems, as well as portables.

X1.3 It has been determined that due to the variety of systems on the market that manufacturers of residential equipment need to be given some basic guidelines, appropriate to all manufacturers, which establish uniform minimum acceptable standards.

X1.4 Because of the changes in the sport, as well as the increased number of consumers owning residential systems, it has been determined that the consumer needs to be educated in the possible dangers, especially in the misuse of the systems.

X1.5 In reviewing the existing safety standards for public playground equipment, it has been determined that these standards are not appropriate for residential basketball equipment.

X1.6 *Edges, Points, and Surfaces (see 5.3)*—The intent of this requirement is to ensure that there be no sharp areas, such as bolts, edges, or points on the equipment that might represent a hazard to the consumer during normal use or reasonable foreseeable misuse.

X1.7 *Pinch, Crush, or Shear Points (see 5.4)*—The intent of this requirement is to ensure that there be no areas within the normal access area on the systems that may entrap causing a contusion, laceration, abrasion, amputation, or fracture during normal use or reasonably foreseeable misuse. It is recommend that a 1/2-in. (13-mm) clearance between closing points be provided to reduce the risk of finger entrapment for children who may ignore or not be aware of warnings given and put their fingers into areas, such as the adjustment mechanism.

X2. RATIONALE FOR STABILITY OF PORTABLE BASKETBALL UNITS

X2.1 The portable basketball system has become a major product in the basketball industry in recent years. It has been determined that it was important that a standard be set concerning the stability of these systems during normal use as these are portable systems, and they will tip over under certain conditions. It is desirable to determine a reasonably simple test method that will determine the acceptable stability of portable systems taking into account various ballast and backboard weights and sizes.

X2.1.1 It is important that a portable system is stable during normal play and that it will not tip over in average wind gusts. The portable systems need to be able to withstand normal wind conditions, 40 mph (64.4 kph), or less (see 6.1.1).

X2.1.2 Because it is known that the portables have the possibility of being pulled over if the user hangs on the rim, it

is important that the warnings attached to the system include a warning not to hang on the rim (see Fig. 9 and Fig. 10).

X2.1.3 If the system tips over because user does not follow warnings, it needs to be manageable and have the ability to return to its upright position from a certain balance point.

NOTE X2.1—An individual of 57.8-in. (146.81-cm) tall with a weight of 81 lb (36.74 kg) has a minimum reach height of 66 in. (1.68 m); therefore, the minimum balance point was set at 66 in. (167.6 cm) and the minimum static vertical load was set at 101.25 lb (45.93 kg) by using a factor of 1.25 to allow for unlevel playing surfaces and dynamic loads. This should allow the small user to be able to release the rim with one's feet on the ground and have the system return to its upright position.

X2.1.4 It is important that the weight distribution of the system is such that if the system tips over, the user has the ability to push the system back off of themselves (see 6.1.2).

ASTM International takes no position respecting the validity of any patent rights asserted in connection with any item mentioned in this standard. Users of this standard are expressly advised that determination of the validity of any such patent rights, and the risk of infringement of such rights, are entirely their own responsibility.

This standard is subject to revision at any time by the responsible technical committee and must be reviewed every five years and if not revised, either reapproved or withdrawn. Your comments are invited either for revision of this standard or for additional standards and should be addressed to ASTM International Headquarters. Your comments will receive careful consideration at a meeting of the responsible technical committee, which you may attend. If you feel that your comments have not received a fair hearing you should make your views known to the ASTM Committee on Standards, at the address shown below.

This standard is copyrighted by ASTM International, 100 Barr Harbor Drive, PO Box C700, West Conshohocken, PA 19428-2959, United States. Individual reprints (single or multiple copies) of this standard may be obtained by contacting ASTM at the above address or at 610-832-9585 (phone), 610-832-9555 (fax), or service@astm.org (e-mail); or through the ASTM website (www.astm.org). Permission rights to photocopy the standard may also be secured from the Copyright Clearance Center, 222 Rosewood Drive, Danvers, MA 01923, Tel: (978) 646-2600; http://www.copyright.com/