



Standard Specification for Mechanical Cold Expansion Insert Fitting With Compression Sleeve for Cross-linked Polyethylene (PEX) Tubing¹

This standard is issued under the fixed designation F1865; the number immediately following the designation indicates the year of original adoption or, in the case of revision, the year of last revision. A number in parentheses indicates the year of last reappraisal. A superscript epsilon (ϵ) indicates an editorial change since the last revision or reappraisal.

1. Scope*

1.1 This specification covers mechanical cold expansion insert fittings with compression sleeve suitable for use with cross-linked polyethylene PEX plastic tubing in $\frac{3}{8}$, $\frac{1}{2}$, $\frac{5}{8}$, $\frac{3}{4}$, and 1 in. and larger nominal diameters that meet the requirements of Specifications F876 and F877. These fittings are intended for use in 100 psi (689.5 kPa) cold and hot water distributions systems operating at temperatures up to and including 180° F (82°C). Included are the requirements for materials, workmanship, dimensions, and markings to be used on the fittings and compression sleeves

1.2 The values stated in inch-pound units are to be regarded as standard. The values given in parentheses are mathematical conversions to SI units that are provided for information only and are not considered standard.

1.3 *This standard does not purport to address all of the safety concerns, if any, associated with its use. It is the responsibility of the user of this standard to establish appropriate safety and health practices and determine the applicability of regulatory limitations prior to use.*

2. Referenced Documents

2.1 ASTM Standards:²

- B16/B16M Specification for Free-Cutting Brass Rod, Bar and Shapes for Use in Screw Machines
- B140/B140M Specification for Copper-Zinc-Lead (Red Brass or Hardware Bronze) Rod, Bar, and Shapes
- B283 Specification for Copper and Copper-Alloy Die Forgings (Hot-Pressed)
- D1600 Terminology for Abbreviated Terms Relating to Plastics
- D2122 Test Method for Determining Dimensions of Thermoplastic Pipe and Fittings

E18 Test Methods for Rockwell Hardness of Metallic Materials

F412 Terminology Relating to Plastic Piping Systems

F876 Specification for Crosslinked Polyethylene (PEX) Tubing

F877 Specification for Crosslinked Polyethylene (PEX) Hot- and Cold-Water Distribution Systems

2.2 ASME Standards:³

B 1.20.1 Pipe Threads General Purpose (inch)

B 16.18 Cast Copper Alloy Solder Joint Pressure Fittings

B 16.22 Wrought Copper and Copper Alloy Solder Joint Pressure Fittings

2.3 NSF International Standards:⁴

NSF 14 Plastic Piping Components and Related Materials

NSF 61 Drinking Water System Components-Health Effects

2.4 MSS Standard:⁵

SP-104 Wrought Copper Solder Joint Pressure Fittings

3. Terminology

3.1 *Definitions*—Definitions are in accordance with Terminology F412 and abbreviations are in accordance with Terminology D1600 unless otherwise indicated.

4. Classification

4.1 This specification covers one class of mechanical cold expansion insert fittings with compression sleeve suitable for use with PEX tubing that meets the requirements of Specification F876 and F877.

5. Materials and Manufacture

5.1 *Fittings*—The fittings shall be made from one of the following metals:

¹ This specification is under the jurisdiction of Committee F17 on Plastic Piping Systems and is the direct responsibility of Subcommittee F17.10 on Fittings.

Current edition approved Dec. 1, 2009. Published January 2010. Originally approved in 1998. Last previous edition approved 2009 as F1865–02a(2009). DOI: 10.1520/F1865-09.

² For referenced ASTM standards, visit the ASTM website, www.astm.org, or contact ASTM Customer Service at service@astm.org. For *Annual Book of ASTM Standards* volume information, refer to the standard's Document Summary page on the ASTM website.

³ Available from American Society of Mechanical Engineers (ASME), ASME International Headquarters, Three Park Ave., New York, NY 10016-5990, http://www.asme.org.

⁴ Available from NSF International, P.O. Box 130140, 789 N. Dixboro Rd., Ann Arbor, MI 48113-0140, http://www.nsf.org.

⁵ Available from Manufacturers Standardization Society of the Valve and Fittings Industry (MSS), 127 Park St., NE, Vienna, VA 22180-4602, http://www.msshq.com.

*A Summary of Changes section appears at the end of this standard

5.1.1 *Machined Brass Fittings*—Machined brass fittings shall be made from material meeting the requirements of Specification B140/B140M Copper Alloy UNS C31400, Specification B16/B16M Copper Alloy UNS C38500, or Copper Alloy UNS No. C27450, or DIN 17660 – CuZn39Pb3.

5.1.2 *Forged Brass Fittings*—Forged brass fittings shall be made from material meeting the requirements of Specification B283 Copper Alloy UNS C37700, or Copper Alloy UNS No. C27450, or DIN 17660-CuZn40Pb2.

5.1.3 *Compression Sleeves*—Compression sleeves shall be made from material meeting the requirements of Specification B140/B140M Copper Alloy UNS C37700, Specification B16/B16M Copper Alloy UNS C38500, or DIN 17660-CuZn39Pb3.

6. General Requirements

6.1 The following sections of Specification F877 constitute a part of this specification:

- 6.1.1 Requirements,
- 6.1.2 Test Methods, and
- 6.1.3 Retest and Rejection

6.2 In addition, when a section with a title identical to that referenced in 6.1, above, appears in this specification, it contains additional requirements that supplement those appearing in F877.

6.3 *Dimensions*—Randomly selected fitting or fittings shall be used to determine dimensions. Measurements shall be made in accordance with Test Method D2122. Determine the diameters by making measurements at four points spaced approximately 45° apart around the circumference. Inspection and gauging of solder joint ends shall be in accordance with ANSI B16.18, ANSI B16.22, or MSS SP-104. Inspection and gauging of taper pipe threads shall be in accordance with ANSI/ASME G1.20.1. All fittings that will be subjected to secondary processes of mechanical marking that affect their dimensional tolerances shall be tested in their final marked configuration.

7. Dimensions

7.1 *Dimensions and Tolerances*—The dimensions and tolerances of fittings and compression sleeves shall be as shown in Fig. 1 and Fig. 2 when measured in accordance with 6.3.

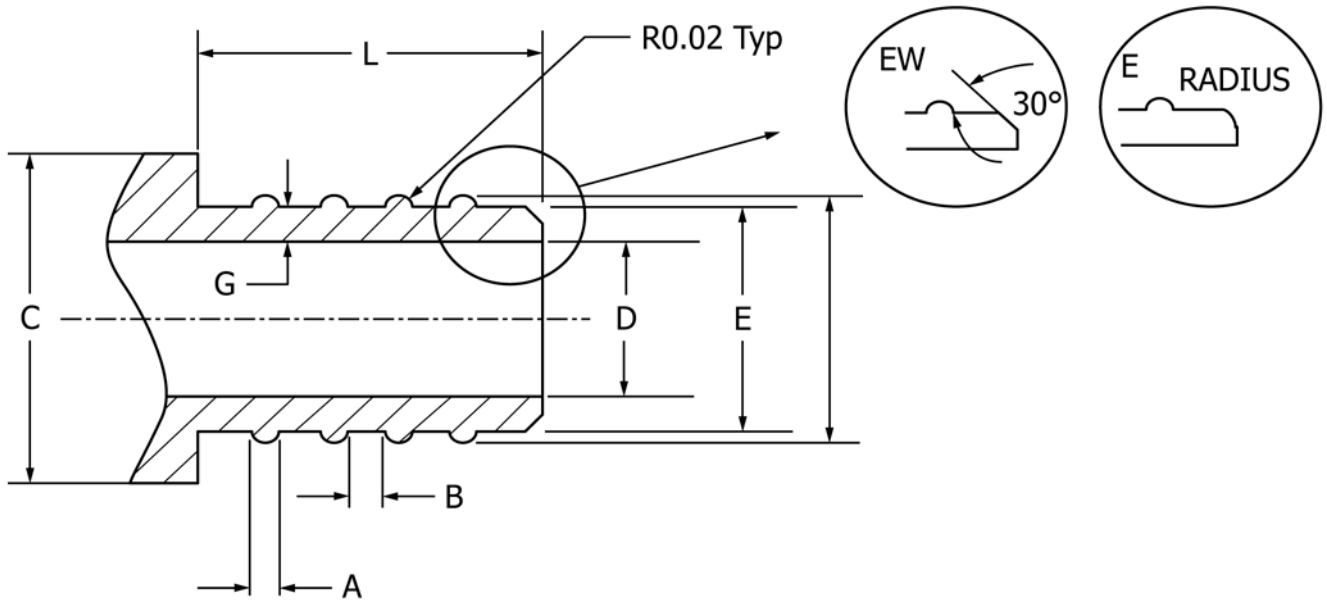

Standard Size	Inches									
	A Rib Width Typ	Number of Ribs	B Gap Width Typ	C Stop Dia. min	D Inside Dia. min	E Insert Diameter	F Rib Diameter	G Minimum Wall	EW EX Depth	L
3/8 in.	0.04 + 0.01	4	0.071 ± 0.010	0.620	0.30	0.370 + 0.008	0.410 + 0.008	0.025	0.020	0.59
1/2 in.	0.04 + 0.01	4	0.071 ± 0.010	0.78	0.40	0.510 + 0.008	0.540 + 0.008	0.040	0.030	0.59
5/8 in.	0.04 + 0.01	4	0.071 ± 0.010	0.86	0.51	0.630 + 0.008	0.670 + 0.008	0.045	0.030	0.59
3/4 in.	0.04 + 0.01	5	0.102 ± 0.010	1.00	0.59	0.730 + 0.008	0.780 + 0.008	0.050	0.035	0.83
1 in.	0.04 + 0.01	5	0.126 ± 0.010	1.40	0.77	0.900 + 0.008	0.950 + 0.008	0.055	0.035	0.94
Metric Size STD (nom)	millimeters									
	A Rib Width Typ	Number of Ribs	B Gap Width Typ	C Stop Dia. min	D Inside Dia. min	E Insert Diameter	F Rib Diameter	G Minimum Wall	EW EX Depth	L
3/8 in. (10 mm)	(1 ± 0.25)	4	(1.8 ± 0.25)	(16)	(7.70)	(9.5 + 0.2)	(10.3 + 0.2)	(0.63)	(0.50)	(15)
1/2 in. (13 mm)	(1 ± 0.25)	4	(1.8 ± 0.25)	(20)	(10.3)	(13.0 + 0.2)	(13.8 + 0.2)	(1.0)	(0.80)	(15)
5/8 in. (16 mm)	(1 ± 0.25)	4	(1.8 ± 0.25)	(22)	(12.9)	(16.0 + 0.2)	17.0 + 0.2)	(1.14)	(0.80)	(15)
3/4 in. (19 mm)	(1 ± 0.25)	5	(2.6 ± 0.25)	(27)	(15.0)	(18.6 + 0.2)	(19.8 + 0.2)	(1.27)	(0.89)	(21)
1 in. (25 mm)	(1 ± 0.25)	5	(3.2 ± 0.25)	(34)	(19.5)	(22.9 + 0.2)	(24.0 + 0.2)	(1.40)	(0.89)	(24)

FIG. 1 Mechanical Insert Dimensions and Tolerances

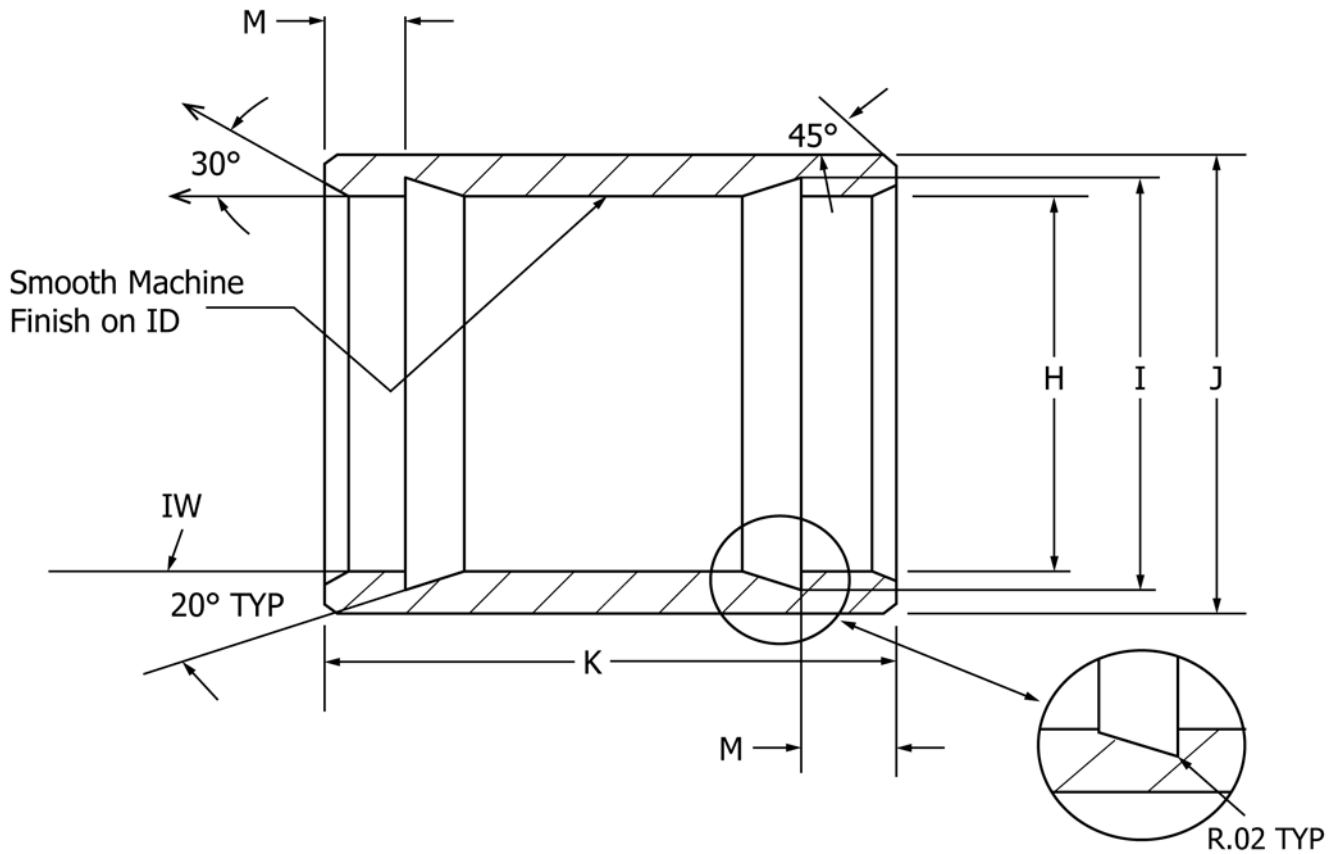

Standard Size	Inches					
	H Inside Diameter	I Groove Diameter	J Outside Diameter	K Length	M Groove Recess	IW Chamfer Depth
3/8 in.	0.52 ± 0.002	0.56 ± 0.01	0.63 ± 0.01	0.59 ± 0.02	0.14	0.04
1/2 in.	0.66 ± 0.002	0.7 ± 0.01	0.75 ± 0.01	0.59 ± 0.02	0.14	0.04
5/8 in.	0.80 ± 0.002	0.84 ± 0.01	0.94 ± 0.01	0.59 ± 0.02	0.14	0.04
3/4 in.	0.93 ± 0.002	0.97 ± 0.01	1.1 ± 0.01	0.73 ± 0.02	0.17	0.04
1 in.	1.15 ± 0.002	1.19 ± 0.01	1.3 ± 0.01	0.91 ± 0.02	0.22	0.04
Metric Size	millimetres					
	STD (nom)	H Inside Diameter	I Groove Diameter	J Outside Diameter	K Length	M Groove Recess
3/8 in. (10 mm)	(13.20 ± 0.05)	(14.2 ± 0.15)	(16.00 ± 0.25)	(15.0 ± 0.5)	(3.5)	(1)
1/2 in. (13 mm)	(16.75 ± 0.05)	(17.75 ± 0.15)	(19.00 ± 0.25)	(15.0 ± 0.5)	(3.5)	(1)
5/8 in. (16 mm)	(20.35 ± 0.05)	(21.3 ± 0.15)	(24.00 ± 0.25)	(15.0 ± 0.5)	(3.5)	(1)
3/4 in. (19 mm)	(23.6 ± 0.05)	(24.5 ± 0.15)	(28.00 ± 0.25)	(18.5 ± 0.5)	(4.25)	(1)
1 in. (25 mm)	(29.25 ± 0.05)	(30.2 ± 0.15)	(33.00 ± 0.25)	(23.0 ± 0.5)	(5.6)	(1)

FIG. 2 Dimensions and Tolerances of Fittings and Compression Sleeves

7.1.1 *Alignment*—The maximum angular variation of any opening shall not exceed 1/2 ° off the true centerline axis.

7.1.2 *Fittings with Solder Joint Ends*—Solder joint ends shall be in accordance with ASME B 16.22, ASME B 16.18B 16.18 or MSS SP-104

7.1.3 *Tapered Threaded Ends*—Fitting threads shall be right-hand conforming to ASME B 1.20.1. They shall be taper threads (NPT).

8. Workmanship, Finish and Appearance

8.1 The sealing, mating and threaded surfaces of the fitting(s) shall be smooth and free of foreign material. The fitting walls shall be free of cracks, holes, blisters, voids, foreign

inclusions, or other defects that are visible to the unmagnified eye and that may affect the wall integrity.

9. Assembly

9.1 *Joints*—Mechanical Cold Expansion Insert Fittings with Compression Sleeve shall be joined to the PEX tubing by drawing a compression sleeve over the PEX tubing that has been cold expanded and into which the fitting has been inserted. This action forces the tubing into annular spaces formed by ribs on the fitting. Fittings and compression sleeves shall meet the dimensional tolerances of this Specification. PEX tubing shall meet the requirements of Specification F876 or F877.

9.1.1 *Solder Joints*— Soldering of fittings joints shall be completed prior to installation of the PEX tubing. Excessive heat from the soldering operation will damage the PEX tubing.

9.2 *Assembly Procedure*—To affix the mechanical cold expansion insert fitting with compression sleeve to the PEX tubing, the procedure shall be as follows: Cut the tubing square using a cutter designed for plastic tubing. Inspect the end for burrs or foreign debris. Slide the compression sleeve onto the tubing at least 1 in. (25 mm) beyond the end of the tube. Insert the properly sized expansion tool (see **Note 1**) fully into the tubing until the end of the tube meets the stop on the tool. Expand the tubing to the fullest reach of the tool. The fullest reach of the tool shall not expand the inside diameter of the tubing more than 0.20 in. (5.0 mm) for sizes up to 5/8 in. nominal and 0.24 in. (6.0 mm) for larger sizes up to 1 in. Insert the fitting into the expanded tube. Place the joining tool onto the fitting assembly in accordance with the tool manufacturers instructions (see **Note 1**). Operate the joining tool to slide the compression sleeve over the tubing and until it reaches the stop on the fitting. Remove the joining tool. Compression sleeves that are damaged in any way shall not be re-used.

NOTE 1—Tool manufacturers provide a variety of expansion tools and joining tools with adapters for use on the various fittings configurations and sizes. These tools may utilize mechanical, electrical, hydraulic, or pneumatic devices to actuate their mechanisms. One inch sizes may not require expansion.

10. Quality Assurance

10.1 When the product or product packing is marked with the ASTM designation F1865, the manufacturer affirms that the product was manufactured, inspected, sampled, and tested in

accordance with this specification, and has been found to meet the requirements of this specification.

11. Product Marking

11.1 *Quality of Marking*—The marking shall be applied to the fittings in such a manner that it remains legible after installation and inspection.

11.2 *Content of Marking*:

11.2.1 Marking on fittings shall include manufacturer's name or trademark, or some other identifying mark. Additional marking shall include ASTM standard number and PEX, if size permits.

11.2.1.1 Where recessed marking is used on fittings, care shall be taken to see that in no case shall the marking cause cracks or reduce the wall thickness below the minimum specified.

11.2.2 Marking on packaging shall include manufacturer's name, fitting size, and ASTM F1865.

11.2.3 Markings on compression sleeves shall include manufacturer's trademark or some other identifying mark and ASTM F1865.

11.3 When the product is marked with this ASTM designation ASTM F1865, the manufacturer affirms that the product was manufactured, inspected, sampled, and tested in accordance with this specification and has been found to meet the requirements of this specification.

12. Keywords

12.1 cold and hot water distribution; cold expansion insert fittings; compression sleeve; crosslinked polyethylene; PEX

SUPPLEMENTARY REQUIREMENTS

This requirement applies whenever a regulatory authority or user calls for product to be used to convey or be in contact with potable water.

S1. *Potable Water Requirements*— Products intended for the transport of potable water shall be evaluated, tested, and certified for conformance with ANSI/NSF Standard No. 61 or

the health effects portion of NSF Standard No. 14 by an acceptable certifying organization when required by the regulatory authority having jurisdiction.

SUMMARY OF CHANGES

Committee F17 has identified the location of selected changes to this standard since the last issue (F1865–02a(2009)) that may impact the use of this standard.

(1) Copper Alloy UNS No. C27450 was added to **5.1.1** and **5.1.2**.

ASTM International takes no position respecting the validity of any patent rights asserted in connection with any item mentioned in this standard. Users of this standard are expressly advised that determination of the validity of any such patent rights, and the risk of infringement of such rights, are entirely their own responsibility.

This standard is subject to revision at any time by the responsible technical committee and must be reviewed every five years and if not revised, either reapproved or withdrawn. Your comments are invited either for revision of this standard or for additional standards and should be addressed to ASTM International Headquarters. Your comments will receive careful consideration at a meeting of the responsible technical committee, which you may attend. If you feel that your comments have not received a fair hearing you should make your views known to the ASTM Committee on Standards, at the address shown below.

This standard is copyrighted by ASTM International, 100 Barr Harbor Drive, PO Box C700, West Conshohocken, PA 19428-2959, United States. Individual reprints (single or multiple copies) of this standard may be obtained by contacting ASTM at the above address or at 610-832-9585 (phone), 610-832-9555 (fax), or service@astm.org (e-mail); or through the ASTM website (www.astm.org). Permission rights to photocopy the standard may also be secured from the Copyright Clearance Center, 222 Rosewood Drive, Danvers, MA 01923, Tel: (978) 646-2600; <http://www.copyright.com/>