



Standard Specification for Stuffing Tubes, Nylon, and Packing Assemblies (Metric)¹

This standard is issued under the fixed designation F1836M; the number immediately following the designation indicates the year of original adoption or, in the case of revision, the year of last revision. A number in parentheses indicates the year of last reapproval. A superscript epsilon (ϵ) indicates an editorial change since the last revision or reapproval.

This standard has been approved for use by agencies of the U.S. Department of Defense.

1. Scope

1.1 This specification covers the general requirements for nylon stuffing tubes and packing assemblies. Nylon stuffing tubes are intended for making electric cable penetrations in marine shipboard enclosures for electrical equipment. The following types are suitable for both thin-wall enclosures up to 5 mm ($\frac{3}{16}$ in.) thick and thick-wall enclosures, bulkheads, and decks of 5 to 19 mm ($\frac{3}{16}$ to $\frac{3}{4}$ in.) thick.

1.2 This specification does not cover metal stuffing tubes.

1.3 The values stated in SI units are to be regarded as standard. No other units of measurement are included in this standard.

1.4 *This standard does not purport to address all of the safety concerns, if any, associated with its use. It is the responsibility of the user of this standard to establish appropriate safety and health practices and determine the applicability of regulatory limitations prior to its use.*

2. Referenced Documents

2.1 *ASTM Standards:*²

D2000 Classification System for Rubber Products in Automotive Applications

D4066 Classification System for Nylon Injection and Extrusion Materials (PA)

2.2 *NEMA Standards:*

Standard 250 Enclosures for Electrical Equipment (1000 V Max)³

¹ This specification is under the jurisdiction of ASTM Committee F25 on Ships and Marine Technology and is the direct responsibility of Subcommittee F25.10 on Electrical.

Current edition approved Dec. 1, 2015. Published January 2016. Originally approved in 1997. Last previous edition approved in 2013 as F1836M – 09 (2013). DOI: 10.1520/F1836M-15.

² For referenced ASTM standards, visit the ASTM website, www.astm.org, or contact ASTM Customer Service at service@astm.org. For *Annual Book of ASTM Standards* volume information, refer to the standard's Document Summary page on the ASTM website.

³ Available from National Electrical Manufacturers Association (NEMA), 1300 N. 17th St., Suite 1752, Rosslyn, VA 22209, <http://www.nema.org>.

2.3 *ASME Standard:*

ASME B1.1 Unified Inch Screw Threads (UN and UNR Thread Form)⁴

2.4 *IEC Standard*

Standard 68-2-6 Environmental Testing—Part 2: Tests—Test FC: Vibration (Sinusoidal) Sixth Edition⁵

3. Terminology

3.1 *Definitions of Terms Specific to This Standard:*

3.1.1 *nylon stuffing tube, n*—a marine electrical fitting used for the sealing of cable penetration into shipboard enclosures while maintaining or exceeding the degree of protection for which the enclosure is rated.

3.1.2 *packing assembly, n*—the compressible insert for the nylon stuffing tube. It consists of one neoprene bushing and three nylon washers.

3.1.3 *enclosure, n*—an electrical panel, cabinet, junction box, light fixture, electrical equipment, control box, or panel.

4. Classification

4.1 Nylon stuffing tubes shall be of the following types (see Fig. 1):

4.1.1 *Type 1*—straight—Unified Form Thread.

4.1.2 *Type 2*—90°—Unified Form Thread.

4.1.3 *Type 3*—NPT—American Standard Pipe Thread.

4.1.4 *Type 4*—Y—Unified Form Thread.

5. Ordering Information

5.1 Orders for stuffing tubes under this specification shall include the following:

5.1.1 Type (see 4.1).

5.1.2 Part number (see Table 1).

5.1.3 Packing assembly size (see Fig. 2 and Table 2).

5.1.4 The O-ring included in the stuffing tube assembly has a finite shelf life. If the stuffing tube assembly is used after the

⁴ Available from the International Electrotechnical Commission, 3 rue de Varembe, Case postale 131, CH-1211, Geneva 20, Switzerland.

⁵ Available from American Society of Mechanical Engineers (ASME), ASME International Headquarters, Two Park Ave., New York, NY 10016-5990, <http://www.asme.org>.

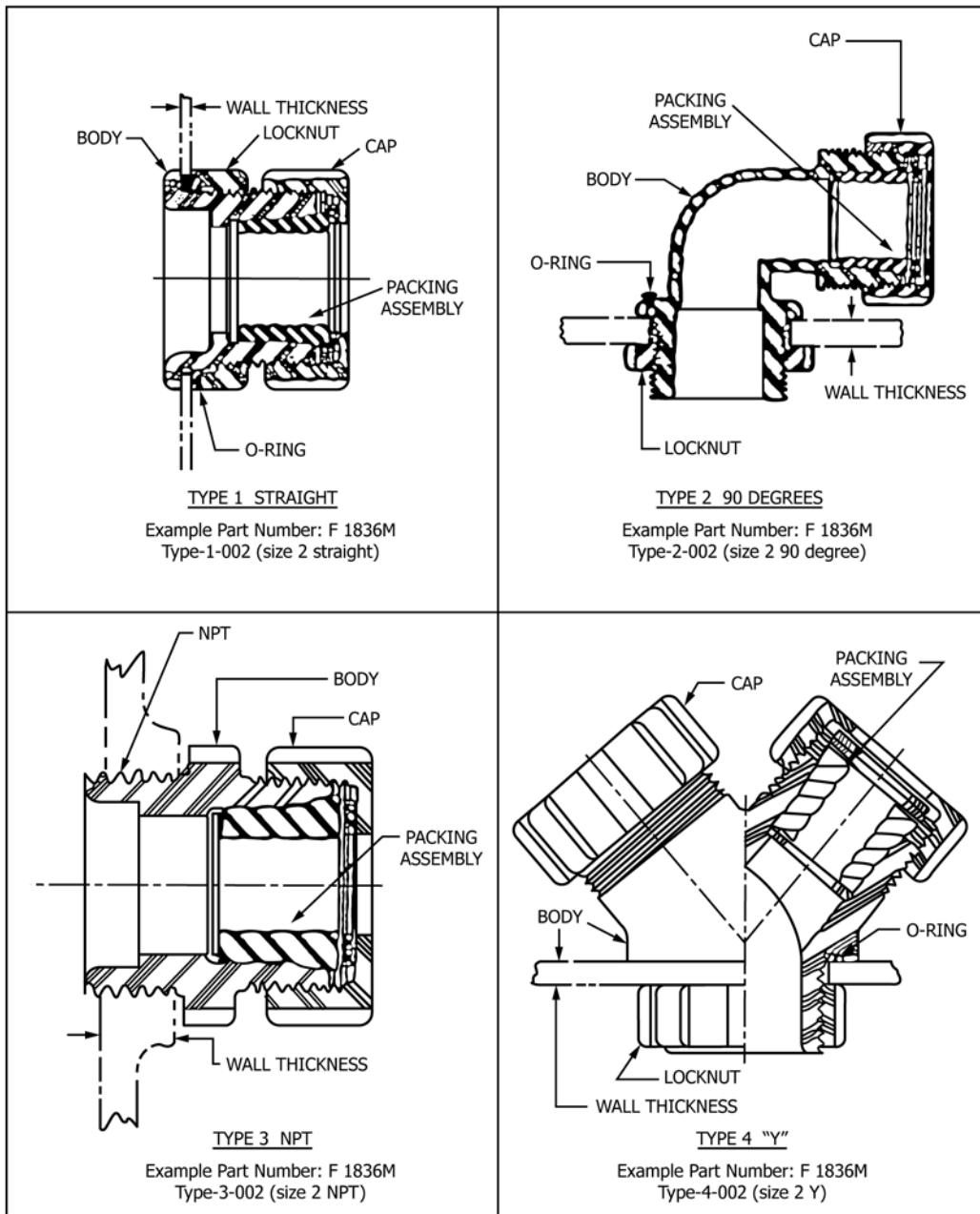

FIG. 1 Stuffing Tube Types

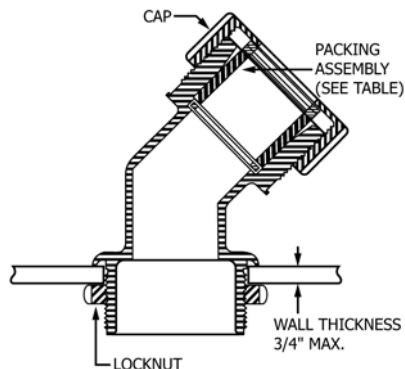

FIG. 1 Stuffing Tube Types (continued)

TABLE 1 Stuffing Tubes Part Numbers and Dimensional Data

Tube Size	Part No.	Cable Range				Packing Assembly ^A	Clearance Hole Diameter for Tube Install		O-Ring Buna-N Size	
		in.		mm			in.	mm		
		min.	max.	min.	max.					
Straight Type 1	Type-1-001	0.077	0.300	1.96	7.62	-16	0.885	22.48	212	
	-002	0.275	0.472	6.99	11.99	-17	1.010	25.65	214	
	-003	0.410	0.472	10.41	11.99	-18	1.135	28.83	216	
	-004	0.450	0.777	11.43	19.74	-19	1.260	32.00	218	
	4T	-005	0.450	0.777	11.43	19.74	-19	1.385	35.18	220
	-006	0.752	1.113	19.10	28.27	-20	2.010	51.05	226	
	-007	0.806	1.390	20.47	35.31	-21	2.510	63.75	230	
	-008	1.433	1.610	36.40	40.89	-22	2.760	70.10	232	
	-009	1.625	2.00	41.28	50.80	-23	3.260	82.80	236	
-010	2.030	2.700	51.56	68.58	-24	4.010	101.85	242		
90° Type 2	Type-2-001	0.077	0.300	1.96	7.62	-16	0.885	22.48	212	
	-002	0.275	0.472	6.99	11.99	-17	0.885	22.48	212	
	-003	0.410	0.472	10.41	11.99	-18	1.135	28.83	216	
	4T	-005	0.450	0.777	11.43	19.74	-19	1.260	32.00	218
	-006	0.752	1.113	19.10	28.27	-20	2.010	51.05	220	
	-007	0.806	1.390	20.47	35.31	-21	2.510	63.75	230	
NPT Type 3	Type-3-001	0.077	0.300	1.96	7.62	-16	0.5			
	-002	0.275	0.472	6.99	11.99	-17	0.75			
	-003	0.410	0.472	10.41	11.99	-18	1.0			
	4T	-004	0.450	0.777	11.43	19.74	-19	1.0		
	-005	0.752	1.113	19.10	28.27	-20	1.5			
	-006	0.806	1.390	20.47	35.31	-21	2			
	-007	1.433	1.610	36.40	40.89	-22	2.5			
	-008	1.625	2.00	41.28	50.80	-23	3			
	-009	2.030	2.700	51.56	68.58	-24	3.5			
Y Type 4	Type-4-001	0.077	0.300	1.96	7.62	-16	0.885	22.48	212	
	-002	0.275	0.472	6.99	11.99	-17	1.010	25.65	214	
	-003	0.410	0.472	10.41	11.99	-18	1.135	28.83	216	
	4T	-004	0.450	0.777	11.43	19.74	-19	1.385	35.18	220
NYST Type 5	Type-5-001-004									
	-005	0.752	1.113	19.10	28.27	-20	2.010	51.05		
	-006	0.806	1.390	20.47	35.31	-21	2.510	63.75		

^A See Table 2 size selection.

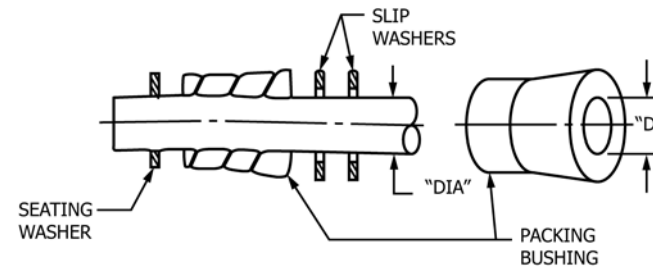

FIG. 2 Typical Packing Assembly

shelf life has expired, the O-ring should be replaced, using the appropriate size listed in Table 1.

5.1.5 ASTM Part Number. The part number comprises the ASTM specification number, type designator and assigned dash number as shown in the following example:

F1836M	Type-3	-002
ASTM	Part Type	Size
Designator	Designator	Designator

Example: F1836M Type-3-002: Size 2 NPT stuffing tube (see Fig. 1).

6. Materials and Manufacture

6.1 Materials:

6.1.1 Polyamide (nylon) molding plastic material shall be Group 1, Class 8, Grade 1 in accordance with Specification D4066.

6.1.2 Synthetic rubber (neoprene) shall be in accordance with Classification D2000, M2, BC, 410, A14, B14, C12, and F19.

TABLE 2 Packing Assembly Size

NOTE 1—Packing assembly selection requires that the packing bushing inner diameter (*D*) be equal or slightly larger than the cable maximum diameter (DIA).

NOTE 2—I.D. column indicates the bushing inner diameter.

Tube Size	Part No.	Cable Range				Tube Size	Part No.	Cable Range			
		in.		mm				in.		mm	
		min.	I.D. max.	min.	I.D. max.			min.	I.D. max.	min.	I.D. max.
1	16-001	0.137	0.187	3.48	4.75	6	21-001	1.119	1.159	28.42	29.44
	-002	0.077	0.127	1.96	3.23		-002	1.127	1.167	28.63	29.64
	-003	0.100	0.150	2.54	3.81		-003	1.160	1.200	29.46	30.48
	-004	0.184	0.234	4.67	5.94		-004	1.204	1.254	30.58	31.85
	-005	0.228	0.278	5.79	7.06		-005	1.255	1.305	31.89	33.15
	-006	0.244	0.300	6.20	7.62		-006	1.309	1.350	33.25	34.29
2	17-001	0.275	0.325	6.99	8.26	-007	1.350	1.390	34.29	35.11	
	-002	0.317	0.367	8.05	9.32	-008	0.856	0.886	21.74	22.50	
	-003	0.340	0.390	8.64	9.91	-009	0.926	0.956	23.52	24.28	
	-004	0.375	0.425	9.53	10.80	-010	0.776	0.806	19.71	20.47	
	-005	0.422	0.472	10.72	11.99	22-001	1.418	1.458	36.02	37.03	
3	18-018	0.410	0.472	10.41	11.99	-002	1.460	1.500	37.08	38.10	
	19-001	0.450	0.500	11.43	12.70	-003	1.510	1.566	38.35	39.78	
	-002	0.497	0.547	12.62	13.89	-004	1.570	1.610	39.88	40.89	
4 and 4T	-003	0.534	0.584	13.56	14.83	23-001	1.610	1.641	40.89	41.68	
	-004	0.559	0.609	14.20	15.47	-002	1.645	1.688	41.78	42.87	
5	-005	0.610	0.665	15.49	16.89	-003	1.695	1.735	43.05	44.07	
	-006	0.650	0.700	16.51	17.78	-004	1.745	1.812	44.32	46.03	
	-007	0.669	0.719	16.99	18.26	-005	1.816	1.859	46.13	47.22	
	-008	0.727	0.777	18.47	19.74	-006	1.860	1.906	47.24	48.41	
	-009	0.710	0.760	18.03	19.30	-007	1.905	1.935	48.39	49.15	
	20-001	0.737	0.777	18.72	19.74	-008	1.940	2.000	49.28	50.80	
	-002	0.772	0.812	19.61	20.63	24-001	2.006	2.046	50.95	51.97	
	-003	0.813	0.853	20.65	21.67	-002	2.050	2.093	52.07	53.16	
	-004	0.849	0.889	21.57	22.58	-003	2.100	2.140	53.34	54.36	
	-005	0.889	0.937	22.58	23.80	-004	2.150	2.285	54.61	58.04	
5	-006	0.937	0.980	23.80	24.89	-005	2.295	2.385	58.29	60.05	
	-007	0.981	1.021	24.92	25.93	-006	2.375	2.418	60.33	61.42	
	-008	1.000	1.042	25.40	26.47	-007	2.428	2.540	61.67	64.52	
	-009	1.033	1.073	26.24	27.25	-008	2.560	2.700	65.02	68.58	
	-010	1.073	1.113	27.25	28.27						

6.2 Manufacture:

6.2.1 Molded nylon parts, such as body, washers, locknut, and cap, shall meet the requirements specified herein.

6.2.2 Threads shall be unified form UN 2A or 2B or taper pipe thread (NPT) as specified in ASME Standard B1.1.

6.2.3 Neoprene parts, such as bushing and plug, shall meet the requirements specified in Classification **D2000**, and when assembled in a stuffing tube, shall meet the performance requirements specified herein.

7. Other Requirements

7.1 Performance Requirements:

7.1.1 *Vibration Resistance*—When stuffing tubes are tested as specified in **9.1**, there shall be no evidence of cracking or loosening of parts.

7.1.2 *Ruggedness*—When stuffing tubes are subjected to a mechanical abuse test as specified in **9.2**, there shall be no cracking, breaking, distortion, or damage to the sample.

7.1.3 *Effectiveness of Seal*—When stuffing tubes are tested as specified in **9.3**, there shall be no evidence of leakage through or around the stuffing tubes.

8. Workmanship, Finish, and Appearance

8.1 Stuffing tubes shall be free from warp, cracks, chipped edges or surfaces, blisters, uneven surfaces, scratches, dents,

and heat marks. They shall be free from fins, burrs, and unsightly finish caused by chipping, filing, or grinding without subsequent buffing or polishing. All molded nylon parts shall be cleaned thoroughly of annealing mediums. Packing assemblies shall be free of voids, pin holes, flash, or other imperfections, that may impair their serviceability.

9. Test Methods

9.1 Conformance testing of a random sample may be requested by the purchaser to verify that selected performance characteristics specified herein have been incorporated in the stuffing tube design and maintained in production.

9.1.1 *Vibration*—The stuffing tubes shall be subjected to vibration testing as specified in IEC Standard 68-2-6. The following details shall apply:

9.1.1.1 The stuffing tubes shall be complete with O-rings and 1- to 2-m (3- to 6-ft) lengths of cable of appropriate size.

9.1.1.2 The free end of the cables shall be secured to prevent excessive cable whipping action during test.

9.1.1.3 Tests are to be carried out in three perpendicular planes.

9.1.1.4 Duration of the test for no resonance condition shall be 90 min at 30 Hz. Duration at each resonance frequency at which $Q > 2$ is recorded. It is recommended as guidance that Q does not exceed 5.

9.1.1.5 Test range shall be 2 ± 0.3 Hz to 13.2 Hz – amplitude ± 1 mm: 13.2 to 100 Hz – acceleration ± 7 g.

9.1.1.6 Nonconformance to the requirements of 7.1.1 shall be cause for rejection.

9.2 *Mechanical Abuse Test:*

9.2.1 Mechanical abuse test shall be conducted on the sample stuffing tubes assembled with packing assembly on the end of a 2-m (6-ft) length of electrical cable of appropriate size.

9.2.2 The stuffing tube shall be allowed to swing on a radius, while suspended by the electrical cable, from a vertical surface and strike against a vertical flat steel plate on that surface. The vertical distance through which the stuffing tube is allowed to fall shall be 1.5 m (5 ft), and the number of impacts shall be ten.

9.2.3 The stuffing tube shall be disassembled and examined. Nonconformance to the requirements of 7.1.2 shall be cause for rejection.

9.3 *Level of Effectiveness*—A complete stuffing tube with O-ring installed and properly assembled to a cable or with a plug installed shall conform to the performance requirements of NEMA 250. The NEMA enclosure-type designation (4, 4X, 6, 6P) shall establish the appropriate environmental capability (see NEMA 250) required of the installed stuffing tube assembly.

9.3.1 Nonconformance to the requirements of 7.1.3 shall be cause for rejection.

10. Inspection

10.1 *Visual and Dimensional Examination*—Samples shall be examined visually to verify that the materials, design, construction, physical dimensions, marking, and workmanship are as specified in the applicable requirements.

11. Certification

11.1 *Plastic Material Certification*—Material certification shall be required from the manufacturer of the plastic material to ensure the material was manufactured, sampled, tested, and inspected in accordance with Specification D4066. Material identity, traceable to this certification, shall be maintained throughout the manufacturing process.

11.2 Cure date information of all rubber products shall be recorded on the manufacturer's certificate of conformance. The year and quarter of manufacture shall be listed.

11.3 When specified in the purchase order or contract, the purchaser shall be furnished certification that samples representing each lot have been either tested or inspected as directed in this specification and the requirements have been met. When

specified in the purchase order or contract, a report of the test results shall be furnished.

12. Product Marking

12.1 Each nylon stuffing tube component body, locknut, cap, bushing, and washers shall have permanent marking in 3-mm ($\frac{1}{8}$ -in.) high raised letters as size permits. For size-sensitive components, reduced marking is acceptable. Marking shall indicate the following:

12.1.1 Manufacturer's name or trademark and tube size.

12.1.2 Identification markings of prior or superseded specifications or government drawings. These markings are acceptable. New molds or molds that require rework shall contain, if required, the ASTM designation number of this specification and part number. The location of the ASTM marking shall apply to the stuffing tube only and be located on the stuffing tube body. Marking in accordance with 12.1.1 shall apply to all stuffing tube components.

13. Packaging

13.1 Packaging shall be manufacturer's commercial practice and shall be sufficient to afford adequate protection against deterioration and physical damage during shipment from the manufacturer or supplier, or both, to the using activity.

NOTE 1—Bulk packaging for nylon stuffing tubes; unit packaging for packing assemblies.

14. Quality Assurance

14.1 *Responsibility for Inspection*—Unless otherwise specified in the contract or purchase order, the manufacturer is responsible for the performance of all inspection requirements as specified herein. Except as otherwise specified in the contract or purchase order, the manufacturer may use his own or any other facilities suitable for the performance of the inspection requirements specified.

14.2 *Responsibility for Compliance*—All items must meet all the requirements of Section 7. The inspection set forth in this specification shall become a part of the manufacturer's overall inspection system or quality program. The absence of any inspection requirements in the specification shall not relieve the manufacturer of the responsibility of assuring that all products or supplies submitted to the customer for acceptance comply with all the requirements of the contract. Sampling in quality conformance does not authorize submission of known defective material either indicated or actual, nor does it commit the purchaser to acceptance of defective material.

15. Keywords

15.1 cable entry seal; cable penetrator; stuffing tube

SUPPLEMENTARY REQUIREMENTS

The following supplementary requirements are applicable to DoD procurements and shall apply only when specified by the purchaser in the contract or purchase order.

S1. Referenced Documents**S1.1 Military Specifications:**

MIL-S-901 Requirements for Shock Tests, H.I. (High-Impact), Shipboard Machinery, Equipment, and Systems⁶

S2. Shock Tests

S2.1 Stuffing tubes shall be subjected to the high-impact shock test for Grade A, Type A, Class I equipment as specified in MIL-S-901. The details specified in 9.1 and 9.2 shall apply. Nonconformance to the requirements of S2.2 shall be cause for rejection.

S2.2 *Examination After Shock Tests*—When stuffing tubes are tested as specified in S.2.1, there shall be no evidence of cracking, breaking, distortion, or loosening of parts.

S3. Level of Effectiveness (See 9.3)

S3.1 *Submersible and Open Submersible*—Equipment shall be submergence tested to a depth of 4.5 m (15 ft) at 44.8 KPa (6.5 psi) for 24 h. Nonconformance to the requirements of 7.1.3 shall be cause for rejection.

S3.2 *Examination After Immersion*—Failure for stuffing tube to operate satisfactorily shall be cause for rejection. For enclosures including terminal boxes, as revealed by subsequent disassembly and examination, leakage of water into any part of the enclosure shall be cause for rejection.

S4. Packaging

S4.1 *Preservation, Packing, and Marking*—Preservation and packing may be commercial. Marking information shall include cure date, shelf life, and expiration dates of rubber products.

⁶ Available from the Standardization Document Order Desk, 700 Robbins Ave., Bldg. 4D, Philadelphia, PA 19111-5098.

ASTM International takes no position respecting the validity of any patent rights asserted in connection with any item mentioned in this standard. Users of this standard are expressly advised that determination of the validity of any such patent rights, and the risk of infringement of such rights, are entirely their own responsibility.

This standard is subject to revision at any time by the responsible technical committee and must be reviewed every five years and if not revised, either reapproved or withdrawn. Your comments are invited either for revision of this standard or for additional standards and should be addressed to ASTM International Headquarters. Your comments will receive careful consideration at a meeting of the responsible technical committee, which you may attend. If you feel that your comments have not received a fair hearing you should make your views known to the ASTM Committee on Standards, at the address shown below.

This standard is copyrighted by ASTM International, 100 Barr Harbor Drive, PO Box C700, West Conshohocken, PA 19428-2959, United States. Individual reprints (single or multiple copies) of this standard may be obtained by contacting ASTM at the above address or at 610-832-9585 (phone), 610-832-9555 (fax), or service@astm.org (e-mail); or through the ASTM website (www.astm.org). Permission rights to photocopy the standard may also be secured from the Copyright Clearance Center, 222 Rosewood Drive, Danvers, MA 01923, Tel: (978) 646-2600; http://www.copyright.com/