



Designation: F1831 – 17

# Standard Specification for Cranial Traction Tongs and Halo External Spinal Immobilization Devices<sup>1</sup>

This standard is issued under the fixed designation F1831; the number immediately following the designation indicates the year of original adoption or, in the case of revision, the year of last revision. A number in parentheses indicates the year of last reapproval. A superscript epsilon ( $\epsilon$ ) indicates an editorial change since the last revision or reapproval.

## 1. Scope\*

1.1 This specification covers standards a manufacturer shall meet in the designing, manufacturing, testing, labeling, and documenting of halo and tong external spinal immobilization devices, but it is not to be construed as production methods, quality control techniques, manufacturer's lot criteria, or clinical recommendations.

1.2 This specification represents the best currently available test procedures at this time and is a minimum safety and performance standard.

1.3 This specification covers only those halo and tong devices intended for use on humans for therapeutic purposes. This specification assumes the user is well-trained in the procedures and maintenance of halo and tong application and has the ability to determine if an abnormality is treatable by these procedures.

1.4 This specification describes those devices commonly known as halo external fixation devices and what is known as cranial traction tongs.

1.5 Cranial traction tongs and halo devices are used to achieve and maintain optimal spinal alignment, in order to enhance fusion and decrease neurological deficit.

1.6 Monitoring the progress of treatment after application of these devices is important, this should be done in accordance with the manufacturer's recommendation and guidelines pertaining to the specific device.

1.7 The values stated in both inch-pound and SI units are to be regarded separately as the standard. The values given in parentheses are for information only.

1.8 The following precautionary statement pertains only to the test method portions, Sections 10 – 13: *This standard does not purport to address all of the safety concerns, if any, associated with its use. It is the responsibility of the user of this*

<sup>1</sup> This specification is under the jurisdiction of ASTM Committee F04 on Medical and Surgical Materials and Devices and is the direct responsibility of Subcommittee F04.31 on Neurosurgical Standards.

Current edition approved June 1, 2017. Published July 2017. Originally approved in 1997. Last previous edition approved in 2014 as F1831 – 97(2014). DOI: 10.1520/F1831-17.

*standard to establish appropriate safety and health practices and determine the applicability of regulatory limitations prior to use.*

1.9 *This international standard was developed in accordance with internationally recognized principles on standardization established in the Decision on Principles for the Development of International Standards, Guides and Recommendations issued by the World Trade Organization Technical Barriers to Trade (TBT) Committee.*

## 2. Referenced Documents

### 2.1 ASTM Standards:<sup>2</sup>

F2052 Test Method for Measurement of Magnetically Induced Displacement Force on Medical Devices in the Magnetic Resonance Environment

F2119 Test Method for Evaluation of MR Image Artifacts from Passive Implants

F2182 Test Method for Measurement of Radio Frequency Induced Heating On or Near Passive Implants During Magnetic Resonance Imaging

F2213 Test Method for Measurement of Magnetically Induced Torque on Medical Devices in the Magnetic Resonance Environment

F2503 Practice for Marking Medical Devices and Other Items for Safety in the Magnetic Resonance Environment

### 2.2 IEC Standard:

IEC 601-1 Medical Electrical Equipment<sup>3</sup>

## 3. Terminology

### 3.1 Definitions of Terms Specific to This Standard:

3.1.1 *cranial traction tong*—a device providing weighted cervical traction to a patient through invasive attachment to the skull. This traction instrument is indicated for closed reduction of a cervical spine injury (that is, fracture or dislocation).

3.1.1.1 *adjustable tong*—a cranial traction tong that adjusts for size, pin positioning, or pin pressure.

<sup>2</sup> For referenced ASTM standards, visit the ASTM website, [www.astm.org](http://www.astm.org), or contact ASTM Customer Service at [service@astm.org](mailto:service@astm.org). For *Annual Book of ASTM Standards* volume information, refer to the standard's Document Summary page on the ASTM website.

<sup>3</sup> Available from American National Standards Institute (ANSI), 25 W. 43rd St., 4th Floor, New York, NY 10036, <http://www.ansi.org>.

\*A Summary of Changes section appears at the end of this standard

3.1.1.2 *one-piece tong*—a rigid, single-piece, semicircular cranial traction tong designed to accommodate a minimum of two skull pins for mounting the device to the patient's head below the equator.

3.1.2 *halo device*—an external fixator for cervical stabilization that fastens by invasive means to a patient's skull, and maintains the position of the skull in relation to the thoracic area of the patient.

3.1.3 *halo ring*—the portion of the halo device that fastens by invasive means to a patient's skull below the head equator.

3.1.3.1 *closed loop halo ring*—a halo ring incorporating a closed loop anywhere in the design for purposes of structural integrity when the ring is in use. This type of ring has multiple positioning options for the selection of pin sites and is mounted to the head with multiple skull pins.

3.1.3.2 *head equator*—the greatest circumference of the head in the coronal aspect.

3.1.3.3 *open loop halo ring*—a halo ring with a posterior opening, such that the part does not incorporate a closed loop anywhere in the design for structural integrity. This ring has multiple position options for the selection of pin sites and is mounted to the head with multiple skull pins.

3.1.4 *halo superstructure*—a rigid external framework used to maintain positioning of the skull and cervical spine in relation to the thoracic and lumbar spine. Connects the halo ring to halo vest.

3.1.4.1 *halo superstructure adjustment mechanisms*—components that allow adjustment of angles and distances between ring and uprights or vest and uprights.

3.1.4.2 *transverse bar*—a rigid horizontal component of the halo superstructure.

3.1.4.3 *upright bar*—a rigid vertical component of the halo superstructure.

3.1.4.4 *vest attachment mechanism*—attaches inferiorly to the halo superstructure and connects to vest shell, maintains positioning of the halo superstructure in relation to the vest shell.

3.1.4.5 *vest plate*—part of the superstructure attached to the vest shell to provide a stable mounting point for the vest attachment mechanisms.

3.1.5 *halo vest*—a body-orthosis that serves as a mounting point for the halo and superstructure.

3.1.5.1 *C.P.R. access*—mechanism in vest or superstructure to allow quick access to patient's chest for cardiopulmonary resuscitation (C.P.R.).

3.1.5.2 *vest liner*—padding worn inside of halo vest shell and against the skin which distributes the pressure of the vest shell against the skin.

3.1.5.3 *vest shell*—rigid portion of body orthosis.

3.1.6 *skull pin*—a rigid device used to invasively anchor the halo ring or cranial traction tongs to the skull at selected mounting points.

3.1.6.1 *adjustable skull pin*—(1) a pin that is force controlled by a mechanical mechanism, that is, spring-loaded

pressure pin. (2) a solid threaded pin that maintains pressure and fixation against the skull through application of a calibrated torque.

3.1.6.2 *fixed skull pin*—a pin that is mounted directly to a tong structure requiring a drilled skull hole for positioning and fixation. Pressure is not adjusted directly through the pin.

3.1.7 *traction bail (traction hoop)*—a device that may be attached to the halo ring to facilitate the application of weighted longitudinal traction.

## 4. Conformance

4.1 Presently, this specification is voluntary and not by law. A manufacturer may label a product as conforming to this specification only if the product indeed meets all the requirements of this specification.

## 5. Classification

5.1 *Halo External Fixator*—Typically a complete system consisting of the halo ring, skull pins, vest and superstructure. The uniqueness of this system is its ability to provide self-contained cervical stabilization.

5.2 *Cranial Traction Tongs*—Either a rigid single-piece, semicircular device or an adjustable device. Both designs have accommodations for at least two skull pins to be mounted to the skull. Typically designed to be fitted over the top of the head and used for weighted cervical reduction or bed traction, or both, in the supine (bed restricted) patient.

## 6. Magnetic Resonance Imaging Compatibility Requirements

6.1 These halo external fixator and cranial traction tong magnetic resonance imaging (MRI) compatibility requirements are intended to protect the patient from harm during MRI imaging procedures.

6.2 Manufacturers shall be responsible for testing the MRI safety and efficacy of the device.

6.2.1 *Test Methods*—See Section 13.

## 7. Mechanical Integrity

7.1 The purpose of this requirement is to ensure the user and the patient that the halo external fixator or cranial traction tongs, or both, are capable of withstanding the externally imposed conditions normally encountered during the useful life of the device.

7.2 *Cranial Traction Tongs Mechanical Integrity:*

7.2.1 The cranial traction tongs and any of its components must be manufactured from a material that provides suitable rigid support to the skull pins and any other attached components including the traction weights.

7.2.2 Cranial traction tong pins shall be sufficiently strong to resist at least two times the normal maximum static loads that may be encountered during normal wear.

7.2.3 The cranial traction tongs and its components shall be resistant to deformation and sufficiently rigid such that pin position and pressure on the skull can be maintained at maximum manufacturer's specified pin pressures.

7.2.4 Adjustable skull pins shall be calibrated with force indicators.

7.2.5 *Test Method*—See Section 10.

7.3 *Halo Skull Pin Mechanical Integrity:*

7.3.1 Halo skull pins shall be sufficiently strong to resist at least two times the normal maximum static and dynamic loads that may be encountered during normal use.

7.3.2 *Test Method*—See Section 11.

7.4 *Halo Ring Mechanical Integrity:*

7.4.1 The halo ring shall be manufactured from a material that provides suitable rigid support to the attached skull pins and superstructure.

7.4.2 The halo ring shall be resistant to deformation and sufficiently rigid such that pin position and pressure on the skull can be maintained at maximum manufacturer's specified pin pressures.

7.4.3 *Test Method*—See Section 11.

7.5 *Halo Superstructure Assemblies Mechanical Integrity:*

7.5.1 A new halo external fixator device must be able to maintain structural integrity under normal physical loading when the system is fully assembled.

7.5.2 All mechanical components of the superstructure assembly must maintain rigidity and functional integrity throughout the useful life of the product.

7.5.3 *Test Method*—See Section 12.

7.6 *Halo Vest Assembly Mechanical Integrity:*

7.6.1 The halo vest assembly must provide a stable platform for rigid attachment of the superstructure.

7.6.2 The halo vest must provide an adjustable means of rigid fixation to the upper body of the patient.

## 8. Performance Requirements

8.1 The purpose of these requirements is to ensure that a halo external fixator or cranial tongs shall meet the minimum performance requirements as originally designed. The halo and tongs device requirements should not vary from procedure to procedure provided they are used and maintained according to the manufacturer's recommendation.

8.2 *Halo External Fixator Performance Requirements:*

8.2.1 All mechanical fixation components will be manufactured out of corrosion resistant materials.

8.2.2 All components shall be manufactured out of materials capable of providing functional integrity over the useful life of the device.

8.2.3 The manufacturer will be responsible to maintain adequate mechanical test data or equivalent clinical data in regard to the suitability of design, useful life and diagnostic imaging compatibility of the system.

8.2.4 The manufacturer will be responsible for supplying materials that are sterilizable by the manufacturer's recommended sterilization techniques.

8.3 *Halo Pin Performance Requirements:*

8.3.1 All portions of the skull pin that are in constant physical contact with the patient's skin shall be manufactured from biologically compatible material.

8.3.2 All halo skull pins shall be supplied with a method for locking the pin in place in the halo ring.

8.4 *Halo Ring Performance Requirements*—The manufacturer will be responsible for providing a ring assembly that allows for the following:

8.4.1 The halo ring shall be able to easily and rigidly attach to the superstructure.

8.4.2 The halo ring shall be able to easily accept a minimum of four halo skull pins.

8.5 *Halo Superstructure Assembly Performance Requirements:*

8.5.1 The halo vest and superstructure assemblies shall be able to be easily attached and detached from the halo ring with the appropriate tools.

8.6 *Halo Vest Performance Requirements:*

8.6.1 The vest material shall be trimmable and moldable with the appropriate tools to allow the medical personnel to provide suitable adaptability to the various anatomies encountered.

8.6.2 The manufacturer will provide suitable vest liner materials to maintain a substrate between the vest shell and the skin. These lining materials shall be free of any chemicals or toxins, or both, that could cause an allergic response in the average patient.

8.6.3 The halo vest shall have a vest attachment mechanism whereby the halo superstructure is suitably attached via the appropriate tools or mechanism.

8.6.4 The halo vest shall allow rapid and complete access to the chest in the event of a cardiac emergency to allow access to the chest for C.P.R.

8.7 *Halo Tools Performance Requirements*—All halo adjustment tools supplied by the manufacturer shall consistently perform in the manner to which they were designed throughout the useful life of the product or as indicated by the manufacturer's recommendations.

8.8 *Cranial Traction Tongs Performance Requirements:*

8.8.1 All mechanical fixation components will be manufactured out of corrosion resistant materials.

8.8.2 All components shall be manufactured out of materials capable of providing functional integrity over the useful life of the device.

8.8.3 The manufacturer will be responsible to maintain adequate mechanical test data or equivalent clinical data in regard to the suitability of design, useful life and diagnostic imaging compatibility of the system.

8.8.4 The manufacturer will be responsible for supplying materials that are sterilizable by the manufacturer's recommended sterilization techniques.

8.8.5 The cranial traction tongs must permit attachment of cables and other necessary hardware.

8.9 *Cranial Traction Tongs Pin Performance Requirements:*

8.9.1 All tong pins must be supplied by the manufacturer with a method of locking.

8.9.2 Any portion of the tong pin that is in direct contact with the patient's skin shall be manufactured from biologically compatible materials.

**9. Disclosures, Labeling, and Documentation**

9.1 These requirements are intended to ensure a manufacturer’s written dissemination of all necessary information that allow a user to determine properly a halo external fixator or cranial traction tongs (and all of their related accessories) function, application and limitation. These disclosures, labeling and documentation requirements also ensure clear identification of the product and make available all pertinent data a user may require. A manufacturer may label his product as conforming to this standard only if the product fulfills all of the requirements listed in this specification.

9.2 *Disclosures*—A manufacturer shall disclose each specification listed where applicable.

9.2.1 *Single Patient Use Statement*—A manufacturer of halo external fixation systems or cranial traction tongs shall provide a warning statement to inform the user that the device is guaranteed for single patient use only.

9.2.2 *Sterilization*—A disclosure statement that states exactly which items of the halo external fixator and the cranial traction tongs and their accessories can be sterilized and the recommended sterilization procedures shall be included with each device.

9.2.3 *Presterilized Components*—A disclosure statement shall be included with each presterilized component of either the halo or the tongs. This statement shall include the following information: the device is sterile, the expiration date, notes of caution concerning means of shipping, storage and use of the instrument, and lot and batch information.

9.2.4 *Imaging Compatibility*—Manufactures shall be responsible for labeling the product according to imaging compatibility to avoid confusion by the end user.

**9.3 Labeling:**

9.3.1 All required labeling shall be legible in terms of size and color as dictated by FDA guidelines (21 CFR 820). The labeling must also be durable to last the life of the product and permanently attached so as not to be lost.

9.3.2 All halo external fixators and cranial traction tongs shall be labeled so as to contain the following information:

- 9.3.2.1 Model number and size,
- 9.3.2.2 Manufacturer or distributor name, or both,
- 9.3.2.3 Serial number or lot and batch number,
- 9.3.2.4 Diagnostic imaging compatibility indicators, and
- 9.3.2.5 C.P.R. access indicators.

9.3.3 If labeling is not conducive to direct attachment to the device then all information shall be provided in the manufacturer’s instruction manual or on the final packaging.

**9.4 Documentation:**

9.4.1 All halos and tongs shall include instruction manuals.

9.4.2 All instruction manuals shall contain the following information when applicable:

- 9.4.2.1 Recommended sizing and application instructions
- 9.4.2.2 Recommended safe maximum traction loading information for the ring and traction bail or cranial traction tong as the composite system (ring and pins) excluding physiological parameters associated with the patient’s skull.
- 9.4.2.3 CPR access instructions,
- 9.4.2.4 Recommended pin torque settings,

- 9.4.2.5 Cleaning instructions,
- 9.4.2.6 Patient care guidelines,
- 9.4.2.7 Diagnostic imaging compatibility guidelines, and
- 9.4.2.8 Manufacturer or distributor’s name and address, or both.

**10. Test Method for Mechanical Integrity of Cranial Traction Tongs**

10.1 *Scope*—This test method covers the mechanical integrity of tongs with skull pins and their ability to withstand a loading without significant loss of function.

10.1.1 *Summary of Test Method*—The tongs are set up such that the loading is applied at the point on the tongs as it would be under normal use as recommended by the manufacturer. The tongs are supported as described in 10.1.3 and 10.1.3.1. The amount of deflection and ability of the device to withstand the loading is recorded.

10.1.2 *Significance and Use*—For safety reasons, the device shall be designed to withstand a minimum of twice the maximum load typically used during normal short-term clinical applications or as outlined by the manufacturer in the product’s instruction manuals without adverse deflection of any components of the device.

10.1.3 *Apparatus*—Tongs shall be suspended, utilizing any attachment devices supplied with the product by the manufacturer as shown in Fig. 1. Skull pins shall be inserted into the unit and inserted into an aluminum mounting block such that any load applied to the tong will be carried equally by all skull pins and attachment points and so that the resultant load will be applied axially so as not to apply any angular force to the arms of the tongs and in such a way that any load applied to the tongs will be carried equally by all attachment points.

10.1.3.1 *Aluminum Skull Pin Mount*—An aluminum block shall be predrilled to a maximum depth of 2 mm to accommodate the tips of the skull pins.

10.1.3.2 The test specimen shall consist of the manufacturer’s new, finished, untested product.

**10.1.4 Procedure:**

10.1.4.1 If the tongs are adjustable, they shall be set in an average or typical position of use for a head with a lateral width of 17 cm, or to the median position within the range the device is designed to accommodate.

10.1.4.2 Insert the skull pins into the predrilled holes in the aluminum block and tighten them according to manufacturer’s recommendations for optimum force.

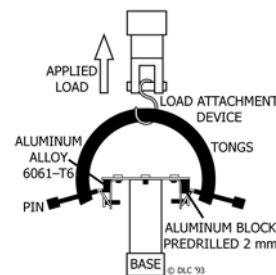

**FIG. 1 Suspended Tongs**



10.1.4.3 Apply a load to the device where skeletal traction is applied in a clinical setting per the manufacturer's instructions. The load may be applied incrementally (maximum 10 lb (g) increments) or continuously at a maximum rate of 0.127 cm/min.

10.1.4.4 Load the device to either 100 kg or twice the maximum safe load recommended by the manufacturer.

10.1.4.5 After the necessary loading is achieved, leave the apparatus in place for a period of 20 min.

10.1.4.6 Document load versus displacement curves throughout the test.

10.1.4.7 After 20 min, unload the device and document the final displacement of the device in the unloaded state.

#### 10.1.5 *Interpretation of Results:*

10.1.5.1 Any tong able to maintain the maximum load without signs of plastic deformation in any components of the device shall have passed the test.

10.1.5.2 Any tong demonstrating plastic deformation in any components of the device after unloading the maximum load shall have failed the test.

### 10.2 *Additional Test Method for Cranial Traction Tongs:*

10.2.1 *Scope*—This test method covers the mechanical integrity of tongs with skull pins and their ability to withstand loading without significant loss of function.

10.2.2 *Summary of Test Method*—The tongs are set up such that the loading is applied at the point on the tongs as it would be under normal use as recommended by the manufacturer. The tongs are supported as described in 10.2.3 and 10.2.3.1. The amount of deflection and ability of the device to withstand the loading is recorded.

10.2.3 *Significance and Use*—For safety reasons, the device shall be designed to withstand a minimum of twice the maximum load typically used during normal long-term clinical applications or as outlined by the manufacturer in the product's instruction manuals without plastic deformation of any component of the device. The rotational and dynamic loading component that occurs in a clinical setting as a result of turning the patient in bed must also be considered.

10.2.4 *Apparatus*—Tongs shall be suspended, utilizing any attachment devices supplied with the product by the manufacturer as shown in Fig. 1. Skull pins shall be inserted into the unit and inserted into an aluminum mounting block such that any load applied to the tong will be carried equally by all skull pins and attachment points and so that the resultant load will be applied axially so as not to apply any angular force to the arms of the tong and in such a way that any load applied to the tongs will be carried equally by all attachment points.

10.2.4.1 *Aluminum Skull Pin Mount*—An aluminum block shall be predrilled to a maximum depth of 2 mm to accommodate the insertion of the tips of the skull pins.

10.2.4.2 The test specimen shall consist of the manufacturer's new, finished, untested product.

#### 10.2.5 *Procedure:*

10.2.5.1 If the tongs are adjustable, they shall be set in an average or typical position of use for a head with a lateral width of 17 cm, or to the median position within the range the device is designed to accommodate.

10.2.5.2 Insert the skull pins into the predrilled holes in the aluminum block and tighten them according to manufacturer's recommendations for optimum force.

10.2.5.3 Apply a load to the device where skeletal traction is applied in a clinical setting in accordance with the manufacturer's instructions. The load may be applied incrementally (maximum 10 lb (g) increments) or continuously at a rate not to exceed 0.127 cm/min.

10.2.5.4 Load the device to 60 kgs.

10.2.5.5 After the necessary loading is achieved, leave the apparatus in place for a period of one week. During this time, alternate loading in increments of approximately 10° from center (+10°, 0°, -10°) once every 24 h to simulate angular traction forces.

10.2.5.6 After one week, measure and document the change in displacement between the arms of the device from the unloaded state to the fully loaded state and back to the unloaded state.

#### 10.2.6 *Interpretation of Results:*

10.2.6.1 Any tong able to maintain the 60 kg load for one week without signs of plastic deformation in any component of the device shall have passed the test.

10.2.6.2 Any tong demonstrating plastic deformation in any component of the device after unloading the 60 kg load shall have failed the test.

## 11. Test Method for Mechanical Integrity of Halo Rings and Attachment Bails

11.1 *Scope*—This protocol has been developed to test the mechanical integrity of halo rings and their corresponding bails, as well as their ability to withstand loading without significant loss of function. The equipment used for this test has been designed to accommodate all known sizes and shapes of halo rings.

11.1.1 *Summary of Test Method*—The halo rings and traction bails are configured to simulate normal use. Loads are applied at the points recommended by the manufacturer for normal traction application. The halo rings and traction bails are supported as described in 11.1.3.

11.1.2 *Significance and Use*—For safety reasons, the device shall be designed to withstand a minimum of twice the maximum load typically used during normal clinical applications or as outlined by the manufacturer in the product's instruction manuals without significant elastic deformation and without any plastic deformation. The traction bail must remain intact throughout testing.

11.1.3 *Apparatus*—The ring shall be suspended, utilizing any traction attachment components supplied with the product by the manufacturer as shown in Fig. 2. Skull pins shall be inserted into the ring and against an aluminum mounting block such that any load applied to the ring will be carried equally by all skull pins and attachment points and so that the resultant load will be applied axially so as not to apply any uneven distribution of load on the pins and in such a way that any load applied to the ring will be carried equally by all attachment points.

11.1.3.1 *Aluminum Skull Pin Mount*—An elliptical aluminum block shall be predrilled to a maximum depth of 1 mm to

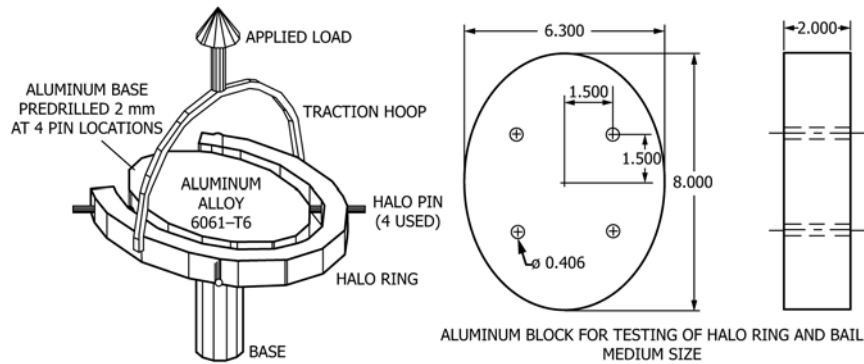

FIG. 2 Suspended Ring

accommodate the tips of the skull pins. The locations of the predrilled holes should be chosen according to manufacturer's recommended pin placement and such that the applied load will be distributed equally by the skull pins.

11.1.3.2 The elliptical aluminum block shall be machined such that the minimum distance between the halo ring and the block is 1 cm. An assortment of aluminum blocks may be necessary to fit all halo ring sizes. If the ring is adjustable, it shall be set in an average or typical position of use for a head with a circumference of 51 cm, or to the median circumference within the range the device is designed to accommodate.

11.1.3.3 The thickness of the elliptical aluminum block may vary depending on whether or not all skull pins lie in the same plane. An example is detailed in Fig. 2.

11.1.3.4 The test specimen shall consist of the manufacturer's new, finished, untested product.

#### 11.1.4 Procedure:

11.1.4.1 Make template of the halo ring prior to testing.

11.1.4.2 Insert the skull pins through the halo ring into the predrilled holes in the mounting block and tighten according to the manufacturer's recommendations for optimum torque.

11.1.4.3 Attach the traction bail to the halo ring such that the applied load will be perpendicular to the halo ring (or as otherwise specified by the manufacturer) and carried equally by the skull pins.

11.1.4.4 Using calipers, make the following measurements before loading:

11.1.4.5 At the locations where the bail is attached to the halo ring, measure the distance from the halo ring to the mounting base.

11.1.4.6 At the locations where the bail is attached to the halo ring, measure the distance from the bottom of the mounting block to the bottom of the halo ring.

11.1.4.7 Measure the distance between the front of the halo ring and the front of the mounting block.

11.1.4.8 At the front of the halo ring, measure the distance from the bottom of the mounting block to the bottom of the halo ring.

11.1.4.9 Apply a 70 kg load to the bail in the position where skeletal traction would be applied for normal use in accordance with the manufacturer's instructions. Apply the load gradually so as not to impart shock loading.

11.1.4.10 Leave the apparatus in place for a period of 20 min. At the end of this period, make the following measurements.

11.1.4.11 At the locations where the bail is attached to the halo ring, measure the distance from the halo ring to the mounting base.

11.1.4.12 At the locations where the bail is attached to the halo ring, measure the distance from the bottom of the mounting block to the bottom of the halo ring.

11.1.4.13 Measure the distance between the front of the halo ring and the front of the aluminum mounting block.

11.1.4.14 At the front of the halo ring, measure the distance from the bottom of the mounting block to the bottom of the halo ring.

11.1.4.15 Remove the skull pins and check the free, unloaded halo ring with the template made in 11.1.4.1.

#### 11.1.5 Interpretation of Results:

11.1.5.1 Compare the measurements from the unloaded halo ring (see 11.1.4.3) to those taken from the loaded halo ring (see 11.1.4.5). If the difference between any of the corresponding measurements exceeds the following, the halo ring has failed the test:

Difference in the distances from the halo ring to the mounting base where the bail attaches to the halo ring: 2 mm.

Difference in the distance from the bottom of the mounting block to the bottom of the halo ring where the bail attaches to the halo ring: 2 mm.

Difference in the distance between the front of the halo and the front of the mounting block: 2 mm.

Difference in the distance from the bottom of the mounting block to the bottom of the halo ring at the front of the halo: 2 mm.

11.1.5.2 If the halo ring demonstrates any plastic deformation in 11.1.4.15, it has failed the test.

11.1.5.3 If the bail does not remain intact, it has failed the test.

#### 11.2 Additional Test Method for Halo Rings:

11.2.1 Summary of Test Method—Throughout this test, the halo rings and bails are configured to simulate normal use. The load is applied at the point which is recommended by the manufacturer for normal traction. The halo rings and traction bails are supported as described in 11.1.3.

11.2.2 *Significance and Use*—To test for creep of the halo ring, the ring must withstand 50 % of the load described in the previous test for a period of 24 h without significant elastic deformation and without any plastic deformation. The corresponding bail must remain intact throughout the testing.

11.2.3 *Apparatus*—The ring shall be suspended, utilizing any traction attachment components supplied with the product by the manufacturer as shown in Fig. 2. Skull pins shall be inserted into the ring and against an aluminum mounting block such that any load applied to the ring will be carried equally by all skull pins and attachment points and so that the resultant load will be applied axially so as not to apply any uneven distribution of load on the pins and in such a way that any load applied to the ring will be carried equally by all attachment points.

11.2.3.1 The test specimen shall consist of the manufacturer’s new, finished, untested product.

11.2.4 *Procedure:*

11.2.4.1 Make a template of the halo ring prior to testing.

11.2.4.2 Insert the skull pins through the halo ring into the predrilled holes in the mounting block and tighten according to the manufacturer’s recommendations for optimum torque.

11.2.4.3 Attach the bail to the halo ring such that the applied load will be perpendicular to the halo ring and carried equally by the skull pins.

11.2.4.4 Using calipers, make the following measurements prior to loading:

11.2.4.5 At the locations where the bail is attached to the halo ring, measure the distance from the halo ring to the mounting base.

11.2.4.6 At the locations where the bail is attached to the halo ring, measure the distance from the bottom of the mounting block to the bottom of the halo ring.

11.2.4.7 Measure the distance between the front of the halo ring at the front of the mounting block.

11.2.4.8 At the front of the halo ring, measure the distance from the bottom of the mounting block to the bottom of the halo ring.

11.2.4.9 A35 kg load is applied to the bail in the position where skeletal traction would be applied for normal use per the manufacturer’s instructions. The load is applied gradually so as not to impart shock loading.

11.2.4.10 The apparatus is left in place for a period of 24 h. At the end of this period, the following measurements are made:

11.2.4.11 At the locations where the bail is attached to the halo ring, measure the distance from the halo ring to the mounting base.

11.2.4.12 At the locations where the bail is attached to the halo ring, measure the distance from the bottom of the mounting block to the bottom of the halo ring.

11.2.4.13 Measure the distance between the front of the halo ring and the front of the mounting block.

11.2.4.14 At the front of the halo ring, measure the distance from the bottom of the mounting block to the bottom of the halo ring.

11.2.4.15 Remove the skull pins and check the free, unloaded halo ring with the template made in 11.1.4.1.

11.2.5 *Interpretation of Results:*

11.2.5.1 Compare the measurements from the unloaded halo ring (see 11.2.4.3) to those taken from the loaded halo ring (see 11.2.4.5). If the difference between any of the corresponding measurements exceeds the following, the halo ring has failed the test:

11.2.5.2 Difference in the distances from the halo ring to the mounting base where the bail attaches to the halo ring: 2 mm.

11.2.5.3 Differences in the distances from the bottom of the mounting block to the bottom of the halo ring where the bail attaches to the halo ring: 2 mm.

11.2.5.4 Difference in the distance between the front of the halo and the front of the mounting block: 2 mm.

11.2.5.5 Difference in the distance from the bottom of the mounting block to the bottom of the halo ring at the front of the halo: 2 mm.

11.2.5.6 If the halo ring demonstrates any plastic deformation in 11.2.4.15, it has failed the test.

11.2.5.7 If the bail does not remain intact, it has failed the test.

12. Test Method for Mechanical Integrity of Halo Superstructures

12.1 *Scope*—This test method covers the mechanical integrity of halo superstructures and their ability to withstand loading without significant loss of function.

12.1.1 *Summary of Test Method*—The halo superstructures and rings are anchored to a rigid support and loads are applied to the device that connects the halo superstructure to the skull. The halo superstructures are supported as described in 12.1.3. The amount of displacement and ability of the device to withstand the loading is recorded.

12.1.2 *Significance and Use*—For safety reasons, the device shall be designed to withstand a minimum of twice the average load typically used during normal clinical applications or as outlined by the manufacturer in the product’s instruction manuals without significant deflection.

12.1.3 *Apparatus*—An individual rigid fixture shall be constructed for each model of halo superstructure. The fixture shall hold the superstructure in the same position as the superstructure would be held on an average patient. The fixture shall have a rigid rod originating from its base and extend through the approximate center of the device that attaches the superstructure to the skull (see Fig. 3). All measurements of displacements of the superstructure shall be made in relation to this rod.

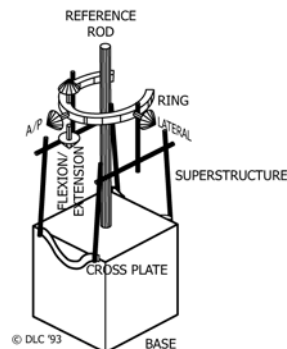

FIG. 3 Attachment of Halo Superstructure

12.1.3.1 The test specimen shall consist of the manufacturer's new, finished, untested product.

12.1.4 *Procedure:*

12.1.4.1 Measure the pretest distance between the rigid rod and the device that connects the superstructure to the skull.

NOTE 1—Pretest measurements shall be taken prior to each separate loading condition.

12.1.4.2 *Loading Conditions:*

12.1.4.3 Apply the load to the device that connects the halo superstructure to the skull.

12.1.4.4 In all cases, apply the load incrementally or all at once but not suddenly so as to impart shock loading.

12.1.4.5 If gravity is the loading mechanism then the weight of the cable, chain or other device should be considered into the total loading.

12.1.4.6 Apply loading separately and non-coincidentally.

12.1.4.7 Loads referenced below are in accordance clinically relevant maximum loads.<sup>4,5</sup>

12.1.4.8 *Anterior/Posterior Direction Loading*—Apply a 23 kg load to the device.

12.1.4.9 *Flexion/Extension Loading*—Apply an 18 kg load to the device.

12.1.4.10 *Lateral Direction Loading*—Apply an 18 kg load to the device.

12.1.4.11 Measure the deflection of the superstructure in relation to the rigid rod after each loading condition.

12.1.5 *Interpretation of Results:*

12.1.5.1 Any superstructure with a measured deflection from the reference rod to the point of load application of greater than 20 mm in the anterior, posterior or flexion/extension directions shall have failed the test. Any superstructure with a measured deflection of greater than 40 mm in the lateral direction shall have failed the test.

12.1.5.2 Any superstructure with a measured deflection from the reference rod to the point of load application less than or equal to 20 mm in the anterior-posterior or flexion/extension direction shall have passed the test. Any superstructure with a measured deflection of less than or equal to 40 mm in the lateral direction shall have passed the test.

### 13. Test Method for Evaluation of the Safety of Halo External Fixators or Cranial Traction Tongs in Magnetic Resonance Imaging (MRI)

13.1 *Scope*—This test method covers the evaluations that are required in order to determine the safety of halo external fixators or cranial traction tongs in a magnetic resonance (MR) environment.

<sup>4</sup> Lind, B. Sihlbom, H. and Nordwall, A., "Forces and Motions Across the Neck in Patients Treated With Halo-Vest," *Spine* 13, 1988, pp. 162–167.

<sup>5</sup> Walker, P.S., Lamser, D., Hussey, R.W., Rossier, A.B., Farberor, A., Dietz, J., "Forces in Halo-Vest Apparatus," *Spine* 9, 1984, pp. 773–777.

13.1.1 *Summary of Test Method*—The displacement force, torque, radiofrequency (RF)-induced heating shall be evaluated according to existing standard test methods.

13.1.2 *Significance and Use*—These test methods are used to determine if the presence of the halo external fixators or cranial traction tongs may cause injury to individuals during an MR examination and in the MR environment.

13.2 The worst case configuration shall be determined for each evaluation, and the tests shall be conducted on the identified worst case configuration.

13.3 *Procedure:*

13.3.1 Perform testing and analyses outlined in Practice **F2503** to evaluate the safety of the device in the MR environment. Label the device MR Safe, MR Unsafe, or MR Conditional as defined in Practice **F2503**.

13.3.1.1 Evaluate the magnetically induced displacement produced by the device. Perform testing and analyses according to Test Method **F2052**.

13.3.1.2 Evaluate the magnetically induced torque produced by the device. Perform testing and analyses according to Test Method **F2213**.

13.3.1.3 Assessment of RF-induced heating for these devices is complex. While Test Method **F2182** is limited to devices entirely implanted inside the body, RF-induced heating can be evaluated experimentally and/or computationally using a method similar to that described in Test Method **F2182**, with modifications for cranial traction tongs and halo external spinal immobilization devices. The components that are in contact with the patient need to be monitored, and particular attention needs to be paid to determining the worst case configuration **(1)**.<sup>6</sup> In addition to the possibility of antenna resonant effects, these devices may create conductive loops that may result in heating.

13.3.2 Evaluate the MR image artifact produced by the device. Perform testing and analyses according to Test Method **F2119**.

13.4 *Interpretation of Results:*

13.4.1 The acceptance criteria should be defined by the manufacturer as clinically applicable to the device.

### 14. Keywords

14.1 cranial traction tongs; halo external fixation device; magnetic resonance imaging (MRI) compatibility

<sup>6</sup> The boldface numbers in parentheses refer to the list of references at the end of this standard.



## REFERENCES

- (1) Guidance for Industry and Food and Drug Administration Staff, “Assessment of Radiofrequency-Induced Heating in the Magnetic Resonance (MR) Environment for Multi-Configuration Passive Medical Devices,” issued on March 22, 2016, [www.fda.gov/ucm/groups/fdagov-public/@fdagov-meddev-gen/documents/document/ucm452644.pdf](http://www.fda.gov/ucm/groups/fdagov-public/@fdagov-meddev-gen/documents/document/ucm452644.pdf), accessed March 6, 2017.

## SUMMARY OF CHANGES

(1) Previous sections regarding MRI safety testing were replaced with one referring to existing standards developed specifically for MRI safety of medical devices for consistency with the industry.

*ASTM International takes no position respecting the validity of any patent rights asserted in connection with any item mentioned in this standard. Users of this standard are expressly advised that determination of the validity of any such patent rights, and the risk of infringement of such rights, are entirely their own responsibility.*

*This standard is subject to revision at any time by the responsible technical committee and must be reviewed every five years and if not revised, either reapproved or withdrawn. Your comments are invited either for revision of this standard or for additional standards and should be addressed to ASTM International Headquarters. Your comments will receive careful consideration at a meeting of the responsible technical committee, which you may attend. If you feel that your comments have not received a fair hearing you should make your views known to the ASTM Committee on Standards, at the address shown below.*

*This standard is copyrighted by ASTM International, 100 Barr Harbor Drive, PO Box C700, West Conshohocken, PA 19428-2959, United States. Individual reprints (single or multiple copies) of this standard may be obtained by contacting ASTM at the above address or at 610-832-9585 (phone), 610-832-9555 (fax), or [service@astm.org](mailto:service@astm.org) (e-mail); or through the ASTM website ([www.astm.org](http://www.astm.org)). Permission rights to photocopy the standard may also be secured from the Copyright Clearance Center, 222 Rosewood Drive, Danvers, MA 01923, Tel: (978) 646-2600; <http://www.copyright.com/>*