



# Standard Specification for Eye Protective Devices for Paintball Sports<sup>1</sup>

This standard is issued under the fixed designation F1776; the number immediately following the designation indicates the year of original adoption or, in the case of revision, the year of last revision. A number in parentheses indicates the year of last reapproval. A superscript epsilon ( $\epsilon$ ) indicates an editorial change since the last revision or reapproval.

## INTRODUCTION

This is the specification for eye, face, and head protective devices, or EHPD, to be used in the sport of paintball. Paintball is a sport that, like all sports, has intrinsic hazards. These hazards include being hit by paintballs. Protective equipment cannot eliminate all injuries but will substantially reduce their severity and frequency. Participation in this sport by a player implies acceptance of injury risk. The goal of protective equipment is to minimize the risk of injury.

Performance requirements are presented and are intended to minimize injury with minimal impairment of the form and appeal of the sport. This specification is subject to revision as indicated by subsequent injury statistics.

The impact requirements are designed to give eye, adnexa of eye, and head protection from paintball impacts likely to be encountered under game conditions. While the EHPD also may protect the user from other potential impacts, such as running into tree branches, there are many conceivable impacts, including falls from heights, which could exceed the specification and result in eye injury despite the use of the EHPD.

## 1. Scope

1.1 This specification applies to eye, face, and head protective devices, designed for use by players of the sport of paintball, which minimize or significantly reduce injury to the eye, adnexa of eye, face, and head due to paintball impact or penetration, or both.

1.2 EHPDs by nature provide three types of protection. The first type of protection is for the eyes and adnexa of eye and not necessarily for any other parts of the face or head. The second type of protection adds coverage for the ears and face. The third type of coverage adds cranial coverage in addition to that provided to types II and III. These coverage types are defined in Section 8.

1.3 This specification does not limit the wearing of eye-glasses or contact lenses when used in conjunction with the EHPD.

1.4 The values stated in SI units are to be regarded as the standard. The values given in parentheses are for information only.

*1.5 This standard does not purport to address all of the safety concerns, if any, associated with its use. It is the responsibility of the user of this standard to establish appropriate safety and health practices and determine the applicability of regulatory limitations prior to use.*

## 2. Referenced Documents

### 2.1 ASTM Standards:<sup>2</sup>

C1027 Test Method for Determining Visible Abrasion Resistance of Glazed Ceramic Tile

D1003 Test Method for Haze and Luminous Transmittance of Transparent Plastics

F803 Specification for Eye Protectors for Selected Sports

F1979 Specification for Paintballs Used in the Sport of Paintball

F2272 Specification for Paintball Markers

### 2.2 ANSI Standards:

ANSI Z80.3 Requirements for Nonprescription Sunglasses and Fashion Eyewear<sup>3</sup>

ANSI Z87.1 Practice for Occupational and Educational Eye and Face Protectors<sup>3</sup>

<sup>1</sup> This specification is under the jurisdiction of ASTM Committee F08 on Sports Equipment, Playing Surfaces, and Facilities and is the direct responsibility of Subcommittee F08.57 on Eye Safety for Sports.

Current edition approved Nov. 15, 2016. Published November 2016. Originally approved in 1997. Last previous edition approved in 2014 as F1776 – 14. DOI: 10.1520/F1776-16.

<sup>2</sup> For referenced ASTM standards, visit the ASTM website, [www.astm.org](http://www.astm.org), or contact ASTM Customer Service at [service@astm.org](mailto:service@astm.org). For *Annual Book of ASTM Standards* volume information, refer to the standard's Document Summary page on the ASTM website.

<sup>3</sup> Available from American National Standards Institute (ANSI), 25 W. 43rd St., 4th Floor, New York, NY 10036, <http://www.ansi.org>.

### 2.3 CSA Standard:<sup>4</sup>

**CSA Z262.6-02 Specifications for Facially Featured Headforms**

### 2.4 EN Standard:<sup>5</sup>

**EN 168 Personal Eye Protection – Non-Optical Test Method - Section 17 Headforms**

### 2.5 Federal Standards:<sup>6</sup>

**No. 406**

**No. 3022**

## 3. Terminology

### 3.1 Definitions of Terms Specific to This Standard:

3.1.1 *adnexa*, *n*—adjunct parts of the eye, including the orbit, orbital contents, eyelids, and the lacrimal apparatus.

3.1.2 *astigmatism*, *n*—a condition in a lens that creates two axially separated line foci of each object point, the lines being mutually perpendicular. In other words, the lens has two different refractive powers in meridians that are 90° apart.

3.1.3 *base-in*, *adj*—relating to the type of prism imbalance that tends to cause parallel rays of light passing through an EHPD, spaced apart by the interpupillary distance, to converge.

3.1.4 *base-out*, *adj*—relating to the type of prism imbalance that tends to cause parallel rays of light passing through an EHPD, spaced apart by the interpupillary distance, to diverge.

3.1.5 *binocular*, *adj*—relating to the field of view that is shared by both eyes simultaneously.

3.1.6 *caliber*, *n*—the term used to refer to the size of a paintball projectile. Related to the measurement of the diameter of the paintball.

3.1.7 *central viewing zone*, *n*—that part of a lens that has its center in line with the wearer’s line of sight when looking straight ahead. The zone is circular in shape. For the purpose of this specification, it shall be considered to be 38 mm in diameter. The center of the central viewing zone shall be the point of intersection of the line of sight with the lens as mounted on the headform, specified by the manufacturer.

3.1.8 *cleanable*, *adj*—the ability of an EHPD to be made readily free of dirt or grime without being damaged during an appropriate cleaning process, such as the use of soap and water.

3.1.9 *corneal apex*, *n*—The most anterior point of the cornea when the eye is in the primary position.

3.1.10 *coverage*, *n*—those areas of the eye, face, and head as covered by the EHPD as defined in 8.3.

3.1.11 *definition, optical*, *n*—the characteristic of a lens that allows separate distinct points in close proximity to be discerned when looking through the lens.

3.1.12 *dislodge*, *v*—remove or force an object from its original position.

3.1.13 *eye*, *n*—relating to the eye of the headform or the eye of a person wearing an EHPD or that part of an EHPD through which a wearer’s eye would normally look.

3.1.14 *eye of the headform*, *n*—all structures contained within the orbital rim of the specified headform.

3.1.15 *EHPD*, *n*—device that provides protection to the wearer’s eyes, face, and head against paintball impact or penetration, or both.

3.1.16 *haze*, *n*—the fraction of the total transmitted light from a normally incident beam that is not transmitted in a focused condition but scattered by inclusions or surface defects. Excessive haze will reduce contrast and visibility.

3.1.17 *headform*, *n*—as utilized within this standard for the as-worn assessment of EHPDs, key dimensions of which are as provided in CSA Z262.6-02 or EN 168.

3.1.18 *lens*, *n*—transparent part of an EHPD through which the wearer normally sees.

3.1.18.1 *Discussion*—The most common configurations for lenses are single pane and thermal double pane. Thermal double pane lenses are usually constructed from a single pane lens which has a second clear airtight thermal barrier affixed to it to reduce the effects of lens fogging. Some lenses also are treated with chemical solutions to reduce lens fogging.

3.1.19 *lens retention component(s)*, *n*—components, separate from the lens, that are designed to retain the lens in the frame or body of the EHPD.

3.1.20 *luminous transmittance*, *n*—luminous transmittance is a function of the spectral transmittance of the lens weighted by the corresponding ordinates of the photopic luminous efficiency distribution of the CIE (1931) standard colorimetric observer and by the spectral intensity of standard Illumination C (see ANSI Z80.3).

3.1.21 *paintball*, *n*—spherical ball, comprised of a shell and a fill manufactured in accordance with the requirements of Specification **F1979** and designed to be expelled from a paintball marker.

3.1.22 *paintball fragment*, *n*—a part of the shell of the paintball that will not be surrounded completely by a 3 by 5-mm rectangle.

3.1.23 *paintball marker*, *n*—device specifically designed to discharge paintballs which conforms with Specification **F2272**.

3.1.24 *orbital area*, *n*—the area contained in a circle  $r = 20$ -mm centered on the pupil of the specified headform.

3.1.25 *power imbalance*, *n*—a condition that exists when the refractive power created by the right lens of the EHPD is different from that of the left lens.

3.1.26 *prism*, *n*—the angular deviation of a ray of light as it passes through a lens resulting from the angle at which the ray strikes each surface of the lens and the index of refraction of the material from which it is made.

### 3.1.27 *prism imbalance*:

3.1.27.1 *horizontal imbalance*, *n*—the difference in prismatic deviation of incident parallel light beams on the two eyes of an EHPD in the horizontal meridian (see **base-in** and **base-out**).

<sup>4</sup> Available from Canadian Standards Association (CSA), 5060 Spectrum Way, Mississauga, ON L4W 5N6, Canada, <http://www.csa.ca>.

<sup>5</sup> Available from European Committee for Standardization (CEN), Avenue Marnix 17, B-1000, Brussels, Belgium, <http://www.cen.eu>.

<sup>6</sup> Available from Standardization Documents Order Desk, Bldg. 4 Section D, 700 Robbins Ave., Philadelphia, PA 19111-5094, Attn: NPODS.

3.1.27.2 *vertical imbalance, n*—the difference in prismatic deviation between parallel light beams incident on the two eyes of an EHPD in the vertical meridian.

3.1.28 *refractive power, n*—the focusing effect of a lens expressed in diopters.

3.1.29 *spherical power, n*—the average of the maximum meridional astigmatic power and the minimum meridional astigmatic power of a lens.

## 4. Performance Requirements

### 4.1 Optical Requirements:

4.1.1 *Field of View*—When tested in accordance with 6.1, the basic EHPD, without any accessories such as a sun visor installed, shall have a field of view equal to or exceeding the following:

4.1.1.1 *Temporal Field*—50°.

4.1.1.2 *Nasal Field*—30°.

4.1.1.3 *Superior Field*—30°.

4.1.1.4 *Inferior Field*—30°.

4.1.2 *Refractive Tolerances*—When tested in accordance with 6.6, the spherical power shall not be less than  $-0.37$  diopters and shall not exceed  $+0.06$  diopters.

4.1.3 *Astigmatism*—When tested in accordance with 6.6, the astigmatism shall not exceed 0.25 diopters.

4.1.4 *Power Imbalance*—When tested in accordance with 6.6, the power imbalance in corresponding meridians between the two eyes for straight ahead seeing shall not exceed 0.18 diopters.

4.1.5 *Prism*—When tested in accordance with 6.4 or 6.8, the primary viewing position of either eye of a shield shall not exceed 0.5 prism diopters.

4.1.6 *Prism Imbalance*—When tested in accordance with 6.4 or 6.8, the prism imbalance shall meet the following criteria:

4.1.6.1 *Vertical Imbalance*, shall not exceed  $+0.25$  diopters.

4.1.6.2 *Horizontal Imbalances*—Negative values (base-in) shall not be less than  $-0.25$  prism diopters, and positive values (base-out) shall not be more than  $+1.0$  prism diopters.

4.1.7 *Luminous Transmittance*—When tested in accordance with 6.3, the luminous transmittance shall not be less than 60 % for clear lenses and not less than 17 % for tinted lenses unless labeled very dark in which case the minimum transmittance shall be no less than 8 %.

4.1.8 *Haze*—When tested in accordance with 6.5, the haze of the EHPD lens shall not exceed 3 %.

4.1.9 *Optical Quality*—Within the central viewing zone, striae, warpage, surface ripples, or other defects that are apparent under the optical inspection test conditions of 6.2 shall be considered a failure. An exception is when small specks or inclusions, which are not seen when the lens is held close to the eye in the as-worn position, shall not be a cause of rejection.

4.1.10 *Physical Lens Defects*—Within the central viewing zone, pits, scratches, grayness, bubbles, cracks, water marks, or other defects that are apparent under the visible inspection test conditions of 6.7 shall be considered a failure. An exception

that small specks or inclusions, which are not seen when the lens is held close to the eye in the as-worn position, shall not be cause of rejection.

### 4.2 Mechanical Requirements:

4.2.1 When tested in accordance with Section 7, the basic EHPD, without any accessories such as a sun visor installed:

4.2.1.1 No contact by components of the EHPD or paintball fragments with the orbital area of the selected headform shall be permitted.

4.2.1.2 Any visible fracture of the lens, frame, or EHPD constitutes a failure.

4.2.1.3 Any dislodging of the lens from the frame constitutes a failure.

4.2.1.4 Any dislodging of a lens retention component from the EHPD constitutes a failure.

4.2.1.5 Any dislodging of a component of the EHPD that would permit free passage and contact of a 5-mm diameter probe to the orbital area of the selected headform constitutes failure.

4.2.1.6 Any contact of an intact paintball, on the portion of the selected headform protected by the EHPD, after said paintball penetrated or passed through the protective portion of the EHPD, constitutes failure.

4.2.1.7 Any rotation of the headgear system on the selected headform that would permit free passage and contact of a 5-mm diameter probe to the orbital area of the selected headform constitutes failure.

## 5. Sample Preparation

### 5.1 Eye and Head Protective Devices:

5.1.1 Only new and complete EHPDs as offered for sale shall be tested.

5.1.2 EHPDs shall be subjected to a single impact test.

5.1.3 The EHPD shall be conditioned for a minimum of 4 h at the specified temperature prior to each test.

### 5.2 Test Temperatures:

5.2.1 *Cold Test*,  $-12.2^{\circ}\text{C} \pm 2^{\circ}\text{C}$  ( $10^{\circ}\text{F} \pm 3.5^{\circ}\text{F}$ ).

5.2.2 *Room Temp*,  $23^{\circ}\text{C} \pm 2^{\circ}\text{C}$  ( $73^{\circ}\text{F} \pm 3.5^{\circ}\text{F}$ ).

5.2.3 *Hot Test*,  $37.8^{\circ}\text{C} \pm 2^{\circ}\text{C}$  ( $100^{\circ}\text{F} \pm 3.5^{\circ}\text{F}$ ).

### 5.3 Paintballs:

5.3.1 All impact testing shall be done using 68 caliber paintballs manufactured in accordance with the requirements of Specification F1979 and obtained within 30 days of the testing date. The paintball bulk container shall be resealed immediately after each group of paintballs is removed. Paintball storage and nontest handling shall be done at a relative humidity below 55 % and at a temperature between 12.7 and 29°C (55 and 85°F).

5.3.2 Paintballs used for impact testing shall be conditioned in a sealed packet (bag) for at least 4 h at the specified temperature for each test. Impact testing shall be completed within 3 min after removal of the paintballs from their temperature conditioning atmosphere.

5.4 *Headform*—The manufacturer shall normally specify to the testing facility the type and size of headform to be used for testing within this standard. This selection will be based upon the design and size of the EHPD. In the case where the

manufacturer does not specify a specific headform or size the CSA Z262.6-02 Adult Male headform will be considered the default choice.

**TEST METHODS**

**6. Optical Test Methods**

*6.1 Field of View (Angle of Vision):*

*6.1.1 Purpose*—This test method is intended to determine the relative unobstructed angle visually available to the user. With the EHPD mounted on the standard headform, the corneal apex shall be visible to an observer when sighted from the required field angles in accordance with 4.1.1. Any sighting method may be used. Paragraphs 6.1.2 – 6.1.4 give one method.

*6.1.2 Apparatus*—The concept is to mount a CSA headform, size specified by the manufacturer or chosen by the test lab, in a gimbal. Any gimbal that is sufficiently large and sturdy and properly inscribed with horizontal and vertical protractor markings is acceptable. Figs. 1-3 show front and side vertical schematic views of a wooden gimbal that can be constructed with simple tools. Item A is the base and support for horizontal rotation. A protractor should be marked on the base with its center coincident with the axis of rotation. Base A should protrude forward to allow for the protractor markings. These indicate the position of B. Item B comprises the main carriage of the gimbal. Item C comprises the vertically rotating member. Sections CR and CL are the right and left vertical supports. Fig. 2 shows the horizontal view. A window in the left of the vertical B support makes the protractor markings on section CL visible for accurate setting. Section CL can be pie-shaped, providing that a 60° angle can be read. The markings should be made every 5° and marked every ten. A set screw should be threaded into the B section or a ¼-20 nut can be inlayed if section B is wooden. Ensure that ¼-20 thumb screws are available readily for use as the set screw. The location of the standard head should be planned to obtain a good balance for vertical rotations. The horizontal rotation axis should be in the plane of the corneas. The axis themselves can be 12-mm

(½-in.) dowels or 6-mm (¼-in.) metal rods. Fig. 3 shows the location of the pivots for their respective rotations. Fig. 4 shows an example of a test setup. The total path from gimbal to the eye, camera, or light source should be at least 7.31 m (24 ft). Using a mirror facilitates adjusting the gimbal while observing the position of the corneas in the protector. A low power telescope or simply a monocular eye locating ring or washer can be substituted for the video camera. The corneas should be painted white or covered with white or reflecting tape in the form of an 8-mm disk. A high level ambient light is desirable. Visual optics may be replaced with photo detectors in the corneas having separate readout means for the two eyes. A strong light source would replace the video camera in which case a low level of ambient light is desirable. A collimating lens would increase the signal to noise ratio of the photo-detectors. The set up as indicated in the drawing introduces a horizontal angle of error of -0.2° and a vertical angle of error of approximately -0.6° at 60°. The location of the vertical angle of tip is centered in the headform to help balance the gimbal. These errors can be accounted for in the decision process. A longer path between the input and output devices will decrease the errors proportionately.

*6.1.3 Test Procedure*—Mount the EHPD to be tested on the headform in the intended wearing position. Set the gimbal in the straight ahead position and verify the visibility of metered response of the two eyes. The gimbal then is rotated to determine the horizontal and vertical extreme angles of view in all four directions along which the appropriate corneas can be seen monocularly.

*6.1.4 Report*—Record and report the maximum angles of view in all four directions.

*6.2 Optical Quality*—Localized power errors or aberrations that are detected by the visual inspection procedure of 6.2.1 are permissible if no measurable or gross foci meter or telescope target distortion or blur is found when the localized area is examined with an instrument as indicated in 6.2.2.

*6.2.1 Inspection Procedure*—One method of optical inspection is to view a high-contrast grid pattern of dark and white

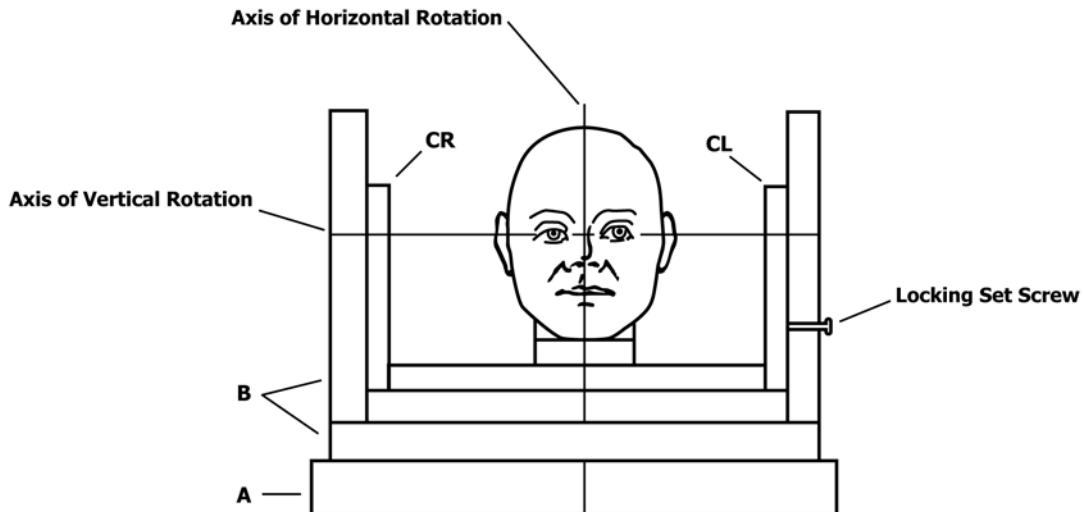

FIG. 1 Schematic of Gimbal for Supporting Standard Head

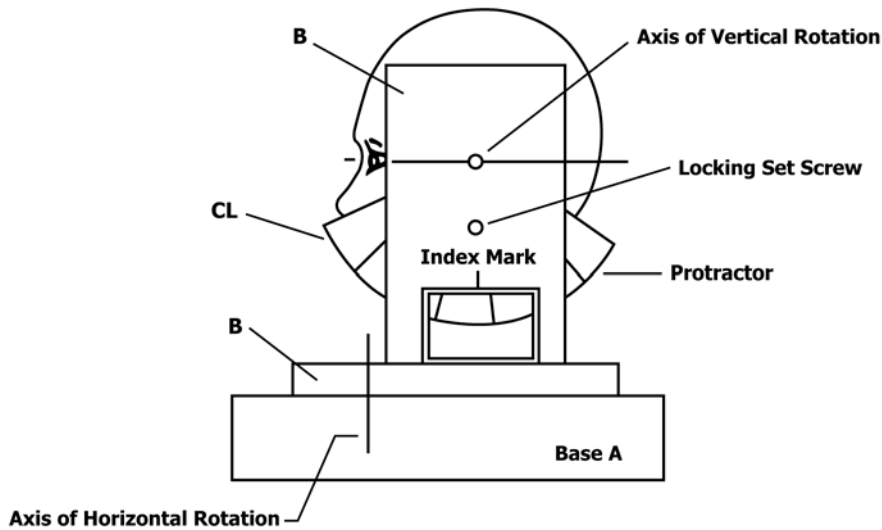

FIG. 2 Side View of Gimbal

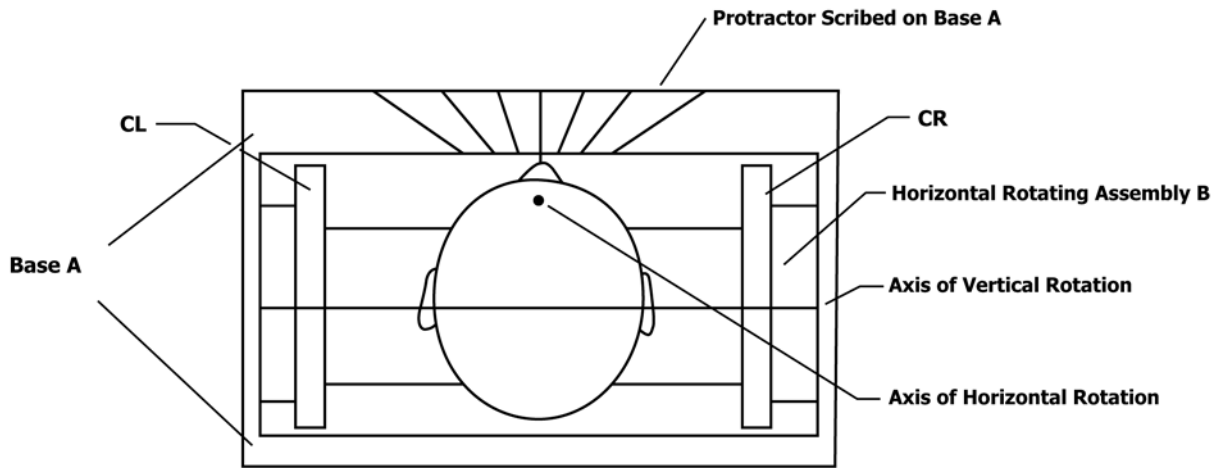

FIG. 3 Top View Showing Base for Horizontal Rotation

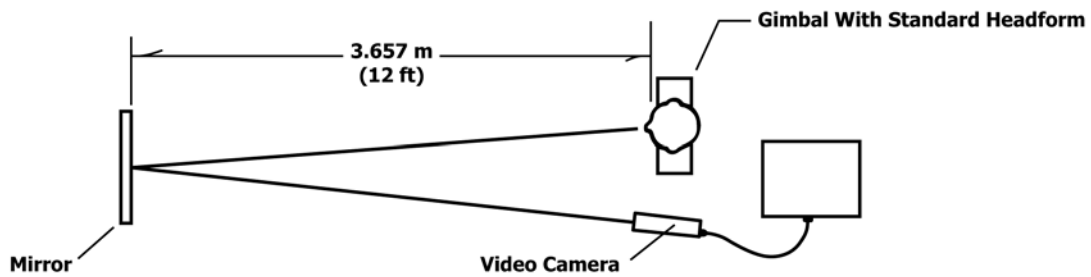

FIG. 4 Bench-Top Field-of-View Setup

lines through the lens, scanning it area by area and moving it about. The grid pattern should be at least 45 by 45 cm (18 by 18 in.) and constructed of high contrast black lines on a white background (the white separations being equal to the black lines, both being approximately 6 mm [ $\frac{1}{4}$  in.] wide). The target should be at least 1.8 to 2.5 m (6 to 8 ft) from the observer, and the lens should be held at least 45 to 60 cm (18 to 24 in.) from the eye. Any ripples in the lens detected by this test method should be further examined in accordance with 6.2.2.

6.2.2 The referee method of detecting optical defects and local aberrations is to scan the central viewing zone, especially areas of suspicion arising from the visual test of 6.2.1. The lens of shield should be scanned with a precision foci meter or an 8 to 10 $\times$  telescope using the targets and arrangements described in 6.6.2 – 6.6.3.2. The aperture should be 5 to 7 mm for this examination. Areas outside the central viewing zone or within 6 mm of the edge need not be tested. When the central viewing area is scanned, there shall be no sudden jump,

doubling, or blurring of the image greater than 0.08 diopters change in power. Gradual variations in the central viewing zone shall be within the power imbalance tolerances. An optical foci meter with electronic readout repeatable to 0.02 diopters is a satisfactory alternate method. These scanning procedures may be made by scanning across the lens surface not necessarily in the “as worn” mode.

**6.3 Luminous Transmittance**—Use a suitable photometer, such as a Gardner Hazemeter, or other device comprised of a light source of CIE Illuminant C at 6774° K color temperature and a photometric probe and meter capable of reading transmission in percent over a range from 1 to 100 %. Use a suitable enclosure to block against stray light and contain the test samples. Following the manufacturers instruction for the use of the instrument, measure the specimen for percent transmittance within each of the two central viewing zones. The measured values shall meet the established criteria for the device. A spectrophotometer, followed by appropriate photometric calculation, also may be used.

**6.3.1** For the purposes of this specification, luminance transmittance may be measured with inexpensive photometers. A fixturing device should be devised to exclude ambient light. The source need not be strictly illuminate C. A tungsten lamp or a screw-in fluorescent lamp provides adequate simulation of the use environment.

#### **6.4 Prismatic Deviation Measurements:**

**6.4.1 Purpose**—This test is intended to measure the angular deviation of light rays created by the EHPD as they pass through the lens(es).

**6.4.2 Apparatus**—A telescope, equipped with a cross hair reticule having a magnification of 8× to 10× and an aperture 19 mm in diameter shall be used. The test method outlined in ANSI Z87.1 has been found satisfactory for this purpose. Other methods that yield comparable results may be used. For this test method, the target distance is 4 m. This target is easier to achieve than longer distances. The target can be metric graph paper divided into 1-cm and 5-mm squares or constructed with a ruler and compass. A circle with a 2-cm radius and a center dot about 1.5 mm in diameter will provide the tolerance for overall prism in one eye. If the 1-cm and 5-mm grids are darkened for 20 mm in each direction from center, with the center lines emphasized, measurements will be easier. Each 5 mm of the scale represents 0.125 prism diopters. The prism values off-center can be labeled along one edge of the 4-cm square vertically and horizontally departing from the central zero. The right side of the target should be labeled plus (+) and the left side minus (−) and vertical top plus (+) and bottom minus (−).

**6.4.3 Test Procedure**—The normal wearing position can be defined as the line of sight through the lenses, which is parallel with the temples when the lenses are held in a normal expected wearing position. Mount the lenses on a fixture such that the right and left eye positions for the testing line of sight are 64 mm apart. One such device is a board with four dowel sticks inserted so that the device can be supported in front of the telescope on a suitable bench or table. A single telescope can be used for straight ahead monocular readings. The fixturing device, for example the block of wood, can be slotted to move

64 mm transversely to easily measure the prism and prism imbalance. The telescope should be focused on the target at 4 m and be aligned carefully with the cross hairs on the zero position of the target. A two meridian screw-adjusted support will help. The readings for the right and left eyes must be recorded by using the graph paper target. The monocular prism test is achieved by noting whether the cross hairs remain in the 20-mm radius circle. Each 5 mm equals 0.125 prism diopters. For the prism imbalance test, readings in prism diopters for each eye must be taken. This is done by recording the amount and direction of displacement of the cross hairs on the target. Apparent movement of the cross hairs in the plus direction is base-out for the right eye and base-in for the left eye whether or not reversed by the telescope. The same is true for vertical measurements. Record the apparent position of the cross hairs on the target with plus and minus signs, in terms of prism diopters. Subtract the left eye readings from the right eye readings. For vertical prism imbalance, the absolute value of the resulting figure is the imbalance. For horizontal prism imbalance, a net positive value indicates the base-out prism imbalance. A net negative value indicates base-in prism imbalance.

**6.4.3.1 Alternate Prism Tests (see 6.8.1)**—Table-top systems with a 1-m sample-to-target distance also are acceptable. The target dimensions should be ¼ of those given in 6.4.2.

#### **6.5 Haze:**

**6.5.1** Measure the EHPD for percent haze within the central viewing zones, with the EHPD rotated so that the passing beam of light is as perpendicular to the testing surface as is practical, in accordance with Test Method **D1003**. The measured values shall meet the established criteria for the device.

**6.5.2** Haze also may be determined with a commercially available Gardner Hazemeter.

#### **6.6 Refractive Power Measurements:**

**6.6.1 Purpose**—This test method is intended to measure spherical and cylindrical refractive power induced by the EHPD.

**6.6.2 Apparatus**—An 8-power telescope with an effective aperture of 19 mm shall be used in conjunction with an illuminated target located a distance of 10.67 m from the telescope objective. The focus adjustment of the telescope shall be calibrated in at least 0.01 diopter increments. The test target shall be that specified by ANSI Z87.1.

#### **6.6.3 Test Procedure:**

**6.6.3.1** Adjust the telescope by setting the calibrated focus adjustment to zero power, then adjust the eyepiece so that the tests target is resolved clearly without the EHPD in front of the telescope. The quality of the telescope and the observer’s vision should be such that Pattern 40 of the High Contrast Test Chart<sup>7</sup> is clearly resolved.

**6.6.3.2** Mount the EHPD in front of the telescope such that the telescope axis passes through either one of the central viewing zones. The angular orientation of the EHPD should be the same as used for prismatic deviation measurements. Take refractive power measurements for both central viewing zones.

<sup>7</sup> See NIST Special Publication 374.

6.6.3.3 Focus the telescope in the radial lines of the test target until they appear as sharp as possible. Two possibilities may occur.

6.6.3.4 If all radial lines appear equally well focused (sharp) at the same telescope power setting, the EHPD has no measurable astigmatism and the power reading of the telescope at that position is the spherical refractive power of the EHPD lens.

6.6.4 Measure the maximum meridional power for each eye, recording the extremes, the most plus readings, and the most negative readings. There will be four readings. If any are more plus than 0.06 or more minus than 0.37 diopter, the power test fails. Also, if any of the readings are more than 0.25 diopters apart, the EHPD is failed for either astigmatism or power imbalance. If the widely spaced errors are on one side of the lens, it is astigmatism.

6.6.5 Alternate methods of measuring refractive power and astigmatism, such as foci meters, visual, and electronic, may be used. Custom optical bench systems are acceptable provided it can be demonstrated that the precision and bias are at least equivalent to the telescope method described in 6.6.3.

#### 6.7 Surface Imperfections and Internal Defects:

6.7.1 Inspect lenses in a lighted room without the aid of magnifying devices.

6.7.2 View lenses against a dark background in the light from an open-shaded 40 W incandescent clear lamp with the lens positioned approximately 305 mm (12 in.) from the light source.

6.7.3 *Visual Function Impairment*—Impairment of the function of the lens may be determined by testing the lens in the “as worn” position before a trained inspector’s eye. Impairment is present if the defects against either light or dark plain backgrounds, with side illumination on the lens for the dark background test.

#### 6.8 Alternate Optical Tests:

##### 6.8.1 Alternative Prism Tests:

6.8.1.1 The target of 6.2.1 (1-cm graph paper subdivided into at least 5-mm squares) is modified as follows: Mark a center point with a black dot not over 1.5 mm in diameter. For a total prism tolerance of 0.50 prism diopters, draw a circle with a 20-mm radius about this center. For vertical prism imbalance tests draw horizontal lines 1 cm above and below center. For a base-in tolerance, draw a vertical line 10 mm to the left of center and for base-out tolerance draw a line 40 mm to the right of center. This target is for use with mirrors and a beam splitter so that both eyes are tested simultaneously. The target for the left eye will be best seen if on black matte paper. The center X can be marked with a red pen. The 20-mm radius circle also should be red. No other lines are necessary.

6.8.1.2 The two targets should be mounted laterally and separated by 64 mm. The left eye target should be mounted on a wooden block or cardboard box so that it is 64 mm closer to the telescope than the right eye target. The set up (see Fig. 5) requires a beam splitter and a 45° mirror between the telescope and the test sample. The mirror and beam splitter must be adjusted carefully and the telescope focused carefully for the 4-m distance. Optical bench equipment will facilitate the adjustments. Thin metal shims on the back of the mirror will

help. When adjusted properly, the black and red centers, as well as the circles, should be superimposed and the cross hairs of the telescope should be on both centers at the same time.

6.8.1.3 To test a sample, mount it in between the telescope and the beam splitter so that the right eye line-of-sight goes through the beam splitter and the left eye line-of-sight goes through the mirror. The cross hairs should lie within both circles. If they do not, then one or both eyes have more than 0.5 prism diopters.

6.8.1.4 For prism imbalance, the red dot of the left eye should lie in the rectangle marked out for the right eye. If it does not, then there is excess prism imbalance.

## 7. Mechanical Tests

### 7.1 Test Equipment:

7.1.1 The propelling device(s) shall be capable of hurling the 68 caliber paintballs horizontally as follows: high velocity mode device,  $122 \pm 6$  m/s ( $400 \pm 20$  ft/s), 1 shot per second for 3 s; and normal velocity mode device,  $94.5 \pm 6$  m/s ( $310 \pm 20$  ft/s) at a rate of 5 shots per second. Each impact velocity shall be measured and if not within the tolerance, that impact series is not valid.

7.1.1.1 If a failure occurs on an EHPD due to a shot that was out of the speed range of the paint ball or the shot location was incorrect, the test will be halted at that point and repeated on a new sample.

7.1.2 Impact testing will be performed at the temperatures specified in 7.2.3.2 and, testing shall be completed within 3 min after removal of the EHPD from the temperature conditioning atmosphere.

7.1.3 Projectiles shall be 68 caliber paintballs and shall be tested as specified in 5.3.

7.1.4 Equipment employed to measure the speed of the test paintball within 1.5 m of impact shall be accurate to within  $\pm 0.5$  m/s muzzle velocity.

7.1.5 The test headform type and size shall be specified by the manufacturer based on the goggle design as referenced in 5.4.

7.1.6 The test headform should be placed in an enclosed area during impact testing to contain paint spray and paintball fragments.

### 7.2 Projectile Test Procedure:

7.2.1 Apply a fresh pressure sensitive marking device, such as a thin layer of pressure sensitive paste, to the orbital area of the test headform before each series of impacts.

7.2.2 Mount the EHPD to be tested on the headform and secure in accordance with the manufacturers instructions.

#### 7.2.3 High Velocity Impact Test:

7.2.3.1 *Sample Size*, one EHPD (eight single impacts).

7.2.3.2 *Test Temperature*, room temperature, condition the EHPD at the temperature specified in 5.2.2.

7.2.3.3 Using the high velocity mode device described in 7.1.1, each impact shall be made at an angle perpendicular to the lens surface. Impact the right side of the lens at the same point overlying the pupil of the right eye of the headform three times at approximately 1-s intervals at  $122 \pm 6$  m/s ( $400 \pm 20$  ft/s). Repeat this impact on the left side of the lens within one

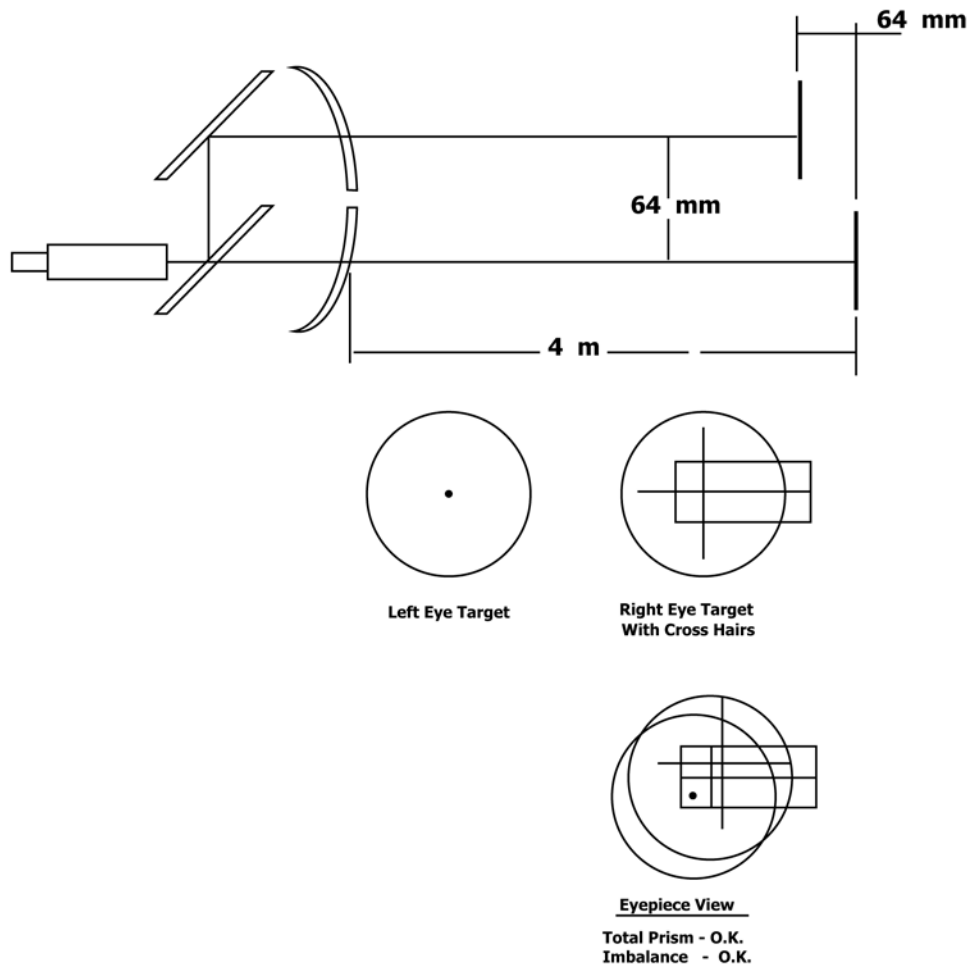

FIG. 5 Alternate Prism Test Set-Up (See 6.8.1)

minute. Then choose two additional locations on each lens at points where the EHPD appears most likely to fail. Impact once at each point.

7.2.3.4 Remove the EHPD from the headform and remove paint by rinsing with tap water. Examine the EHPD for evidence of failure as defined in 4.2.1.2, 4.2.1.3, and 4.2.1.4.

7.2.4 Lens Retention Test:

7.2.4.1 Sample Size, three EHPDs (four sets of five impacts per second).

7.2.4.2 Test Temperatures, cold, room temperature, and hot. Condition one EHPD at each of the temperatures specified in 5.2.1 – 5.2.3.

7.2.4.3 Each impact shall be made with the normal velocity mode device as described in 7.1.1 at  $94.5 \pm 6$  m/s ( $310 \pm 20$  ft/s) at an angle perpendicular to the lens surface and at the junction of the lens and the frame. Select locations around the perimeter of the lens where the product appears most likely to fail. Impact the lens in four locations, five times within 1 s at each location. Choose at least one location at the frame superior, the frame inferior, and the frame temporal as follows:

Frame Superior—Impact at location where lens and frame meet at the top edge of the EHPD.

Frame Inferior—Impact at location where lens and frame meet at bottom of EHPD.

Frame Temporal—Impact at location where lens and frame meet on side of EHPD in line with temple of headform.

7.2.4.4 Remove the EHPD from the headform and remove paint by rinsing with tap water. Examine the EHPD for evidence of failure as defined in 4.2.1.2, 4.2.1.3, and 4.2.1.4.

7.2.4.5 Evaluation of the EHPD (Pass/Fail) in 7.2.3 and 7.2.4 is performed after successful impacts are completed.

7.2.5 Shell Fragment Test:

7.2.5.1 Sample Size, six EHPDs (one set of five impacts).

7.2.5.2 Test Temperatures, cold, room, and hot, as specified in 5.2 (two protectors impacted at each temperature).

7.2.5.3 Each impact shall be made with the normal velocity mode device as described in 7.1.1 at  $94.5 \pm 6$  m/s ( $310 \pm 20$  ft/s) at an angle normal to the lens surface and at the junction of the lens and frame. Select locations around the perimeter of the lens where the product appears most likely to fail, each protector being impacted one time, providing for one set of five impacts within 1 s at each temperature.

7.2.5.4 After each impact, remove the protector from the headform carefully so as not to impart any paint from the protector's outer surface to the headform. Examine the headform for evidence of failure as defined in 4.2.1.

7.3 EHPD System Retention Test:



7.3.1 *Sample Size*, one EHPD (two sets of five impacts).

7.3.2 *Test Temperature*, room temperature, as specified in 5.2.2.

7.3.3 Two sets of impacts, each of five impacts within 1 s, using the normal velocity device described in 7.1.1. Each shall be made at  $94.5 \pm 6$  m/s ( $310 \pm 20$  ft/s) within a 10-s interval in the horizontal corneal plane at an angle of  $110^\circ$  from the normal incident axis. Each impact shall be made at the same point that is on the side surface of the EHPD, midway between the posterior edge of the lens and the posterior border of the EHPD in the horizontal corneal plane.

7.3.4 After all impacts are complete, examine the EHPD for evidence of failure as defined in 4.2.1.6.

7.4 *EHPD Protective Surfaces Impact Test:*

7.4.1 *Sample Size*, three EHPDs (four sets of five impacts).

7.4.2 *Test Temperatures*, cold, room temperature, and hot. Condition one EHPD at each of the temperatures specified in 5.2.1 – 5.2.3.

7.4.3 Using the normal velocity device as described in 7.1.1 each set of impacts shall be made at  $94.5 \pm 6$  m/s ( $310 \pm 20$  ft/s) at an angle perpendicular to the EHPD's head protection surfaces. Select locations where the product appears most likely to fail. Impact the EHPD in four different locations with five impacts within 1 s per location. Choose at least one location at the mouth protection area, the ear protection area, and, if applicable, directly on any exposed lens retention components. Total test time must not exceed 2 min.

7.4.4 Remove the EHPD from the headform and remove paint by rinsing with tap water. Examine the EHPD for evidence of failure as defined in 4.2.1.2 – 4.2.1.6.

7.5 *EHPD Chin Strap Retention System Strength Test:*

7.5.1 *Sample Size*, three EHPDs.

7.5.2 *Test Temperatures*, cold, room temperature, and hot. Condition one EHPD at each of the temperatures specified in 5.2.1 – 5.2.3.

7.5.3 The EHPD will be mounted to the headform as described in the manufacturer's instructions.

7.5.4 A steel drop weight of 1 lb will be attached around the chin strap under the chin area of the headform with a non-stretch flexible strap which will provide a 12-in. free drop length. The strap used in this test must not stretch more than 1 cm (0.39 in.) when the 1-lb weight is hung from it in a stationary position.

7.5.5 The weight will be held touching the chin of the headform directly under the EHPD.

7.5.6 The weight is to be released to allow a free unobstructed drop vertically down from under the chin of the headform.

7.5.7 Remove the EHPD from the headform and examine the chin strap for evidence of breaking free from the EHPD, ripping of the chin strap, or damage to any of the component parts of the chin strap assembly that would affect the proper function and any slippage of the chin strap within any adjustment mechanism by more than 2.54 cm (1 in.). Existence of any of these conditions will result in a failure.

## 8. General Requirements

8.1 *Materials of Construction:*

8.1.1 The manufacturer is responsible that the materials selected meet the following criteria:

8.1.1.1 When exposed to sunlight shall not undergo significant loss of physical properties.

8.1.1.2 When coming into contact with the wearer's face shall not be of a type known to cause skin irritation.

8.1.1.3 When coming into contact with the wearer's face shall not undergo significant loss of strength or flexibility, or other physical change as a result of perspiration, oil, or grease from the wearer's skin and hair.

8.2 *Openings*—All openings in the EHPD, such as those for ventilation, shall be designed in a manner that prevents direct impacts by paintball fragments to the eyes as demonstrated by the test method in 7.2.5. All opening related to the head protection portion of the EHPD shall not allow an intact paintball to come into contact with the mouth, nasal cavities, or ear canals as demonstrated by the test method in 7.4.

8.3 *Level of Head Coverage*—The level of head coverage provided by a EHPD will be described as basic, full, or complete based upon the area of the selected headform covered by the sample EHPD as illustrated in Fig. 6.

8.4 *Determination of the Level of Head Coverage:*

8.4.1 A headform as described in CSA Z262.6-02 is marked with 8 color dots of a diameter of 16 mm numbered 1 through 8 and located as follows: #1 slightly up from between the eyes at the bridge (detent) of the nose, #2 directly over the middle of the mouth, #3 and 4 directly over the ear canals, #5 in the center of the forehead centered between positions A and B on the headform, #6 below the mouth on the upper portion of the chin, #7 on the top of the head at the vertex point, and #8 on the back of the head just below the goggle strap line.

8.4.2 A sample EHPD will be mounted on the headform according to the manufacturers instructions.

8.4.3 The EHPD will then be inspected from all sides and the top and the visible quantity of, as well as corresponding letter marked on the each of the red dots will be recorded. The dots will only be recorded as visible if more than  $\frac{1}{3}$  of the dot is left uncovered by the EHPD.

8.4.4 If the dots marked #1, #2, #3, and #4 are not visible the EHPD will be considered to provide "Basic Coverage".

8.4.5 If the dots marked #1, #2, #3, #4, #5, and #6 are not visible the EHPD will be considered to provide "Extended Coverage".

8.4.6 If the dots marked #1, #2, #3, #4, #5, #6, #7, and #8 are not visible the EHPD will be considered "Complete Coverage".

8.4.7 If the EHPD does not cover the indicated areas in 8.4.3 the unit will be considered as having failed in meeting the minimum required coverage for an EHPD.

8.5 *Retention Components*—The EHPD will include a retention system of a design to ensure the EHPD will remain securely on the users head during the participation in paintball sports activities. This retention system will include a chin strap to aid in stabilizing the EHPD when worn by the user.

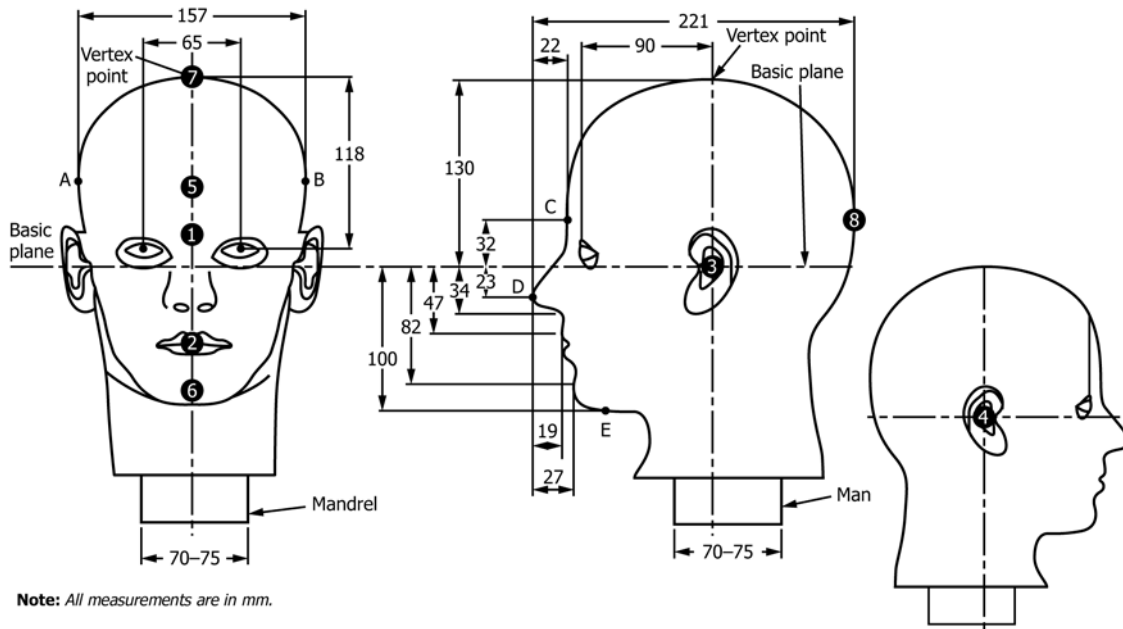

FIG. 6 Headform Details to Determine Coverage Level of EHPD

9. Product Marking

9.1 Each EHPD lens and its primary support structure(s) as defined by the manufacturer or as determined by the laboratory technician shall bear the following permanent marking:

- 9.1.1 Manufacturer’s identity.
- 9.1.2 Month and year of manufacture.

9.2 A label or tag bearing the following information shall be attached to, or shall accompany the EHPD, at the time it leaves the manufacturer:

- 9.2.1 Warning that failure to follow all these instructions or adhere, or both, to all these warnings may result in serious or permanent injury.
- 9.2.2 Warning never to remove the EHPD while on the playing field.
- 9.2.3 Warning to wear the EHPD whenever shooting a paint marker and whenever in or near an area where paintball guns are being shot.
- 9.2.4 Warning that all paintball guns must be chronographed and not to play where paintball velocities exceed 300 fps. Warning to observe at all times the rules of safe play and the rules of safe paint marker handling.
- 9.2.5 A clear statement to the consumer as to the level of head protection provided by the EHPD based upon 8.3 and 8.4.

9.2.6 Warning to check the lens before and after use and to replace the lens immediately if any cracks are observed anywhere in the lens. Warning to replace the lens immediately if the lens is subjected to a direct impact from a paintball from a distance under 10 ft.

9.2.7 Warning to replace the lens after it has been in use for one year.

9.2.8 Warning, for an EHPD with a lens without anti-fog treatment, that fogging may occur, and recommend the application of an anti-fog solution.

9.2.9 Instructions on what anti-fog substance(s) may be used on the lens. Warning not to use other substance(s) on the lens.

9.2.10 Instructions on how to remove and install a lens.

9.2.11 Warning to use only lenses designed to fit the specific EHPD model.

9.2.12 Instructions on how to attach accessories, such as facemask, ear protectors, etc.

9.2.13 Instructions on how to store the EHPD.

9.2.14 Instructions on how to fit the EHPD on the head properly for various head sizes.

9.2.15 Instructions on when and how to clean the EHPD.

TABLE 1 Head Size for Adult Male and Youth Male (as well as Adult Women) with Corresponding Standard Hat Sizes

NOTE 1—All figures listed reflect equivalent body measurement, not actual garment measurement.

Measurements	S/M	M	L	L/XL	XL	XXL	3XL	Adjustable One Size	One Size
Adult Head Size (inches)	21 1/2 –21 7/8	22–22 3/8	22 3/4 –23 1/4	21 1/2 –24	23 1/2 –24	24 1/4	24 1/2	21 1/4 –24 1/2	21–23 7/8
Adult Hat Size	6 5/8 –7	6 7/8 –7	7 1/8 –7 1/4	6 3/4 –7 1/2	7 3/8 –7 1/2	7 5/8	7 3/4	6 5/8 –7 3/4	6 1/2 –7 1/2
Youth Head Size (inches)	19 1/2 –20			20 1/2 –21 1/2					19 1/2 –21 7/8
Youth Hat Size	6 1/8 –6 1/2			6 3/4 –6 5/8					6 1/8 –6 3/4

9.2.16 A statement as to the recommended head size for the fit of the EHPD or alternatively a recommended age range may be used. A reference table of standard North American head sizes is shown in **Table 1** for reference purposes.

9.2.17 A statement as to the type of lens included with the EHPD the two common designations used within the market place are “single pane lens” or “thermal double pane lens.”

9.2.18 A statement or marking as to the caliber or calibers of paintball(s) the manufacturer recommends the EHPD is suitable for use. All recommended calibers of paintball will comply with Specification **F1979**.

9.3 Tinted lenses as referenced in **4.1.7** shall be labeled or marked in a manner selected by the manufacturer at the time of manufacture or distribution with the following statement:

9.3.1 Tinted lenses with a luminous transmittance of less than 17 % will be labeled “**VERY DARK. Not for use in low light conditions.**”

9.3.2 The method of marking selected by the manufacturer may be of a temporary nature which can be removed from the product prior to use by the user such as a removable label on the lens or a hand tag attached to the product.

## **10. Keywords**

10.1 EHPD; eye and head protective devices; eye protective devices; eye protectors; goggles; paintball; paintball sports

## **APPENDIXES**

### **(Nonmandatory Information)**

#### **X1. SUGGESTED DATA REPORT FORMAT**

X1.1 The following information should be included in a test report of tests performed in accordance with this specification:

X1.1.1 Person(s) performing tests and person(s) approving report, with dates.

X1.1.2 Source, description, and numbering of the test specimens.

X1.1.3 Temperature and humidity data should be recorded on data sheets and included in the report as required by this specification.

X1.1.4 Test procedure with appropriate reference to the paragraphs of this specification.

X1.1.5 Description of test equipment with calibration dates and frequency.

X1.1.6 Summary of the data with indications of compliance with the requirements of this specification.

#### **X2. RECOMMENDED METHOD FOR SECURING EHPD TO HEADFORM**

X2.1 If instructions for securing EHPD are not provided, the following method will be used in **7.2.2** – mounting eye protector: Tighten bands or straps (if provided) in such a manner that a force of 3 lb provides no less than a 1 in. space

between the headform and the strap of the EHPD, when a device similar to that indicated in **Fig. X2.1** is inserted under the strap of the EHPD at the center back of the headform.



**FIG. X2.1 Recommended EHPD Securing Clip**

*ASTM International takes no position respecting the validity of any patent rights asserted in connection with any item mentioned in this standard. Users of this standard are expressly advised that determination of the validity of any such patent rights, and the risk of infringement of such rights, are entirely their own responsibility.*

*This standard is subject to revision at any time by the responsible technical committee and must be reviewed every five years and if not revised, either reapproved or withdrawn. Your comments are invited either for revision of this standard or for additional standards and should be addressed to ASTM International Headquarters. Your comments will receive careful consideration at a meeting of the responsible technical committee, which you may attend. If you feel that your comments have not received a fair hearing you should make your views known to the ASTM Committee on Standards, at the address shown below.*

*This standard is copyrighted by ASTM International, 100 Barr Harbor Drive, PO Box C700, West Conshohocken, PA 19428-2959, United States. Individual reprints (single or multiple copies) of this standard may be obtained by contacting ASTM at the above address or at 610-832-9585 (phone), 610-832-9555 (fax), or [service@astm.org](mailto:service@astm.org) (e-mail); or through the ASTM website ([www.astm.org](http://www.astm.org)). Permission rights to photocopy the standard may also be secured from the Copyright Clearance Center, 222 Rosewood Drive, Danvers, MA 01923, Tel: (978) 646-2600; <http://www.copyright.com/>*