



# Standard Specification for Paintball Marker Threaded-Propellant Source Interface<sup>1</sup>

This standard is issued under the fixed designation F1750; the number immediately following the designation indicates the year of original adoption or, in the case of revision, the year of last revision. A number in parentheses indicates the year of last reapproval. A superscript epsilon ( $\epsilon$ ) indicates an editorial change since the last revision or reapproval.

## 1. Scope

1.1 This specification covers the male and female threaded connectors used to interface a propellant source with a normal working output pressure of 10 342 kPa (1800 psig) or less to a paintball marker.

1.2 The values stated in SI units are to be regarded as standard. The values given in parentheses are for information only.

1.3 *This standard does not purport to address all of the safety concerns, if any, associated with its use. It is the responsibility of the user of this standard to establish appropriate safety and health practices and determine the applicability of regulatory limitations prior to use.*

## 2. Referenced Documents

2.1 *ASTM Standards:*<sup>2</sup>

**D2240** Test Method for Rubber Property—Durometer Hardness

**F2272** Specification for Paintball Markers

2.2 *ANSI Standard:*<sup>3</sup>

**ANSI Y14.5M-1994** Dimensioning and Tolerancing

2.3 *CGA Standard:*<sup>4</sup>

**CGA-320 .825-14NGO-RH-EXT** (Flat Nipple)

2.4 *Federal Standard:*<sup>5</sup>

**FED-STD-H28/9A 24 March 1989** Federal Standard Screw-Thread Standards for Federal Services Section 9 Gas Cylinder Valve Outlet and Inlet Threads

2.5 *Military Standard:*<sup>5</sup>

**MS28775** O-Ring Dash Sizes

<sup>1</sup> This specification is under the jurisdiction of ASTM Committee F08 on Sports Equipment, Playing Surfaces, and Facilities and is the direct responsibility of Subcommittee F08.24 on Paintball and Equipment.

Current edition approved April 1, 2016. Published April 2016. Originally approved in 1996. Last previous edition approved in 2015 as F1750 – 11 (2015). DOI: 10.1520/F1750-16.

<sup>2</sup> For referenced ASTM standards, visit the ASTM website, [www.astm.org](http://www.astm.org), or contact ASTM Customer Service at [service@astm.org](mailto:service@astm.org). For *Annual Book of ASTM Standards* volume information, refer to the standard's Document Summary page on the ASTM website.

<sup>3</sup> Available from American National Standards Institute (ANSI), 25 W. 43rd St., 4th Floor, New York, NY 10036.

<sup>4</sup> Available from Compressed Gas Association (CGA), 1725 Jefferson Davis Hwy., Suite 1004, Arlington, VA 22202-4102.

<sup>5</sup> Available from U.S. Government Printing Office Superintendent of Documents, 732 N. Capitol St., NW, Mail Stop: SDE, Washington, DC 20401.

## 3. Connector Gender Assignment

3.1 The female connector is that connector which is configured as part of the paintball marker conforming to Specification **F2272**.

3.2 The male connector is that connector which is configured as part of the propellant source.

## 4. Materials and Manufacture

4.1 The male and female connectors shall be made from materials that are compatible with CO<sub>2</sub>, compressed air, or gaseous nitrogen. The materials and processes used to manufacture male and female connectors shall result in items with mechanical strength sufficient to pass a 20 684-kPa (3000-psig) proof pressure check without failure or any degradation to function.

4.2 The O-ring seal shall be made from an elastomer compatible with CO<sub>2</sub>, compressed air, or gaseous nitrogen. The O-ring seal shall have a hardness that will register a Type A durometer reading of  $90 \pm 5$ . The O-ring shall conform dimensionally to MS28775-015 and conform to Test Method **D2240**.

4.3 The O-ring seal shall be installed on the male connector in the groove described by Dimensions C and K on **Fig. 1**.

4.4 The male and female connectors shall not have any sharp edges or hanging burrs. All sharp edges will be broken R.38 MAX (R.015 MAX).

## 5. Performance

5.1 The interface is intended for use with compressed air, gaseous nitrogen, or CO<sub>2</sub>.

5.2 The maximum operating pressure of the interface is 10 342 kPa (1800 psig).

5.3 The maximum allowable leakage at 10 342 kPa (1800 psig) is 0.1 cm<sup>3</sup>/min.

5.4 The male connector shall incorporate a means for propellant shutoff that shall meet the maximum leakage requirement.

5.5 When the male and female connectors are joined and pressurized, together they shall meet the maximum leakage specification.

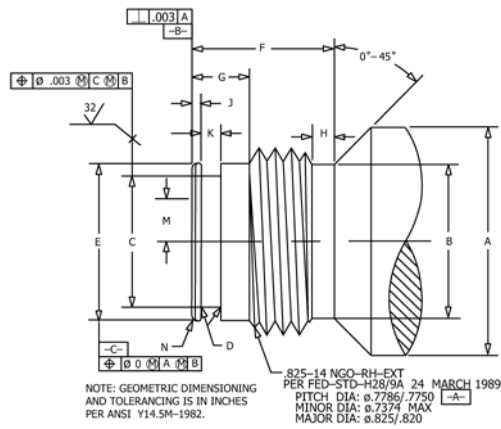

Dimension	SI	Inches
A	φ22.86 min	φ0.900 min
B	φ18.46/17.02	φ0.727/0.670
C	φ14.66 ± 0.08	φ0.577 ± 0.003
D	R.25 ± 0.13	R.010 ± 0.005
E	φ17.60/17.40	φ0.693/0.685
F	16.66 min	0.656 min
G	6.35 ± 0.13	0.250 ± 0.005
H	2.54 ± 0.5	0.100 ± 0.020
J	1.02 ± 0.13	0.040 ± 0.005
K	2.16 ± 0.08	0.085 ± 0.003
N	0.38 ± 0.13 × 45° ± 3°	0.015 ± 0.005 × 45° ± 3°
M	R 5.54 ± 0.38	R.218 ± 0.015

FIG. 1 Male Connector

6. Physical Envelope

6.1 The male connector shall conform to the physical envelope described in Fig. 1.

6.2 The female connector shall conform to the physical envelope described in Fig. 2.

7. Valve Core

7.1 The male connector may contain, as a means of propellant shutoff, a valve core to provide for an automatic shutoff of flow at the time of disconnection. The stem of the valve core shall not protrude beyond the face of the male connector, that surface designated as Datum B in Fig. 1. Full flow must be achieved when the stem of the valve core has been depressed 1.78 mm (0.070 in.) from the surface designated as Datum B in Fig. 1. The stem of the valve core shall be able to be depressed to a minimum depth of 2.54 mm (0.100 in.) below Datum B without being damaged. If a valve core is not used there shall not be any feature of the male connector which will interfere with the valve opening feature of the female fitting.

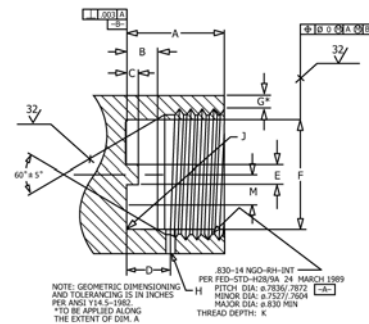

Dimension	SI	Inches
A	15.75 ± 0.13	0.620 ± 0.005
B	5.08 ± 0.13	0.200 ± 0.005
C	1.91 ± 0.13	0.075 ± 0.005
D	7.32 ± 0.13	0.288 ± 0.005
E	3.18 ± 0.13	0.125 ± 0.005
F	φ17.78/17.63	φ0.700/0.694
G	0.89 min	0.035 min
H	φ0.79 min	φ0.031 min
J	R.64 max	R.025 max
K	9.40 min	0.370 min
M	R 4.78 max	R.188 max
O	21.59 ± 0.254	0.85 ± 0.010

FIG. 2 Female Connector

8. Venting

8.1 The female connector shall have a provision for the self venting of residual gas pressure prior to the disconnection of the threaded interface. Fig. 2 (Dimensions D and H) shows a recommended location and feature size for a vent hole.

9. Operating Temperatures

9.1 The interface shall have an operating range from -40° to +54°C (-40° to +130°F).

10. Flow

10.1 The interface shall flow not less than 170 sL/min at 689 kPa (6 S.C.F.M. at 100 psid).

10.2 The feature allowing flow through the female connector shall lie within the area designated by minimum Dimension M in Fig. 2.

10.3 The feature allowing flow through the male connector shall lie within the area designated by Dimension M in Fig. 1.

11. Keywords

11.1 paintball marker; propellant

*ASTM International takes no position respecting the validity of any patent rights asserted in connection with any item mentioned in this standard. Users of this standard are expressly advised that determination of the validity of any such patent rights, and the risk of infringement of such rights, are entirely their own responsibility.*

*This standard is subject to revision at any time by the responsible technical committee and must be reviewed every five years and if not revised, either reapproved or withdrawn. Your comments are invited either for revision of this standard or for additional standards and should be addressed to ASTM International Headquarters. Your comments will receive careful consideration at a meeting of the responsible technical committee, which you may attend. If you feel that your comments have not received a fair hearing you should make your views known to the ASTM Committee on Standards, at the address shown below.*

*This standard is copyrighted by ASTM International, 100 Barr Harbor Drive, PO Box C700, West Conshohocken, PA 19428-2959, United States. Individual reprints (single or multiple copies) of this standard may be obtained by contacting ASTM at the above address or at 610-832-9585 (phone), 610-832-9555 (fax), or [service@astm.org](mailto:service@astm.org) (e-mail); or through the ASTM website ([www.astm.org](http://www.astm.org)). Permission rights to photocopy the standard may also be secured from the Copyright Clearance Center, 222 Rosewood Drive, Danvers, MA 01923, Tel: (978) 646-2600; <http://www.copyright.com/>*