



# Standard Test Method for Determining Mass and Moment of Inertia of Alpine Skis<sup>1</sup>

This standard is issued under the fixed designation F1722; the number immediately following the designation indicates the year of original adoption or, in the case of revision, the year of last revision. A number in parentheses indicates the year of last reappraisal. A superscript epsilon ( $\epsilon$ ) indicates an editorial change since the last revision or reappraisal.

## 1. Scope

1.1 This test method covers test measurement methods for mass and moment of inertia of adult Alpine skis.<sup>2</sup>

1.2 No limitation to ski size is proposed. This test method is applicable to all adult Alpine skis.

1.3 The values stated in SI units are to be regarded as standard. No other units of measurement are included in this standard.

1.4 *This standard does not purport to address all of the safety concerns, if any, associated with its use. It is the responsibility of the user of this standard to establish appropriate safety and health practices and determine the applicability of regulatory limitations prior to use.*

## 2. Referenced Documents

2.1 *ASTM Standards*:<sup>3</sup>

F472 Terminology for Geometry of Alpine Skis

2.2 *ISO Standards*:<sup>4</sup>

ISO 554 Standard Atmospheres for Conditioning and/or Testing—Specifications

ISO 6003 Alpine Skis—Determination of Mass and Polar Moment of Inertia—Laboratory Measurement Method

## 3. Terminology

3.1 *Definitions of Terms Specific to This Standard*:

3.1.1 *mass of ski,  $m$* —the mass of a finished, manufactured ski without any mounted parts, expressed in kilograms.

3.1.2 *moment of inertia,  $I$* —the mass moment of inertia of the ski about its center of gravity, expressed in kilogram-metres squared.

<sup>1</sup> This test method is under the jurisdiction of ASTM Committee F27 on Snow Skiing and is the direct responsibility of Subcommittee F27.30 on Skiing and Snowboarding Equipment.

Current edition approved July 1, 2015. Published August 2015. Originally approved in 1996. Last previous edition approved in 2009 as F1722 – 09. DOI: 10.1520/F1722-15.

<sup>2</sup> This test method is meant to conform in all significant aspects to the test method for determining mass and polar moment of inertia of Alpine skis as set forth in ISO 6003.

<sup>3</sup> For referenced ASTM standards, visit the ASTM website, www.astm.org, or contact ASTM Customer Service at service@astm.org. For *Annual Book of ASTM Standards* volume information, refer to the standard's Document Summary page on the ASTM website.

<sup>4</sup> Available from American National Standards Institute, 11 W. 42nd St., 13th Floor, New York, NY 10036.

## 4. Significance and Use

4.1 This test method provides a means for determining the mass and moment of inertia of adult Alpine skis. It is not intended to evaluate data with regard to the quality of the ski.

## 5. Apparatus

5.1 *Weighing Device*, accurate to  $\pm 0.02$  kg.

5.2 *Fulcrum*, for locating the center of gravity of the ski.

5.3 *Time Measurement Device* (stopwatch), accurate to at least 0.1 s.

5.4 *Measuring Device*, in accordance with Fig. 1, consisting of the following parts:

5.4.1 *Clamping Device*, A, consisting of two clamping fixtures. The top clamping fixture has a hole with a mark to locate the center of gravity and two additional holes at a distance,  $d_f$ , from the center mark for fixation of the filaments, B. The recommended dimension for  $d_f$  is 75 mm, and the mass of the clamping device shall be less than 0.1 kg.

5.4.2 *Top Plate*, C, with two holes separated by the distance  $2d_f$  for the fixation of filaments, B. The plate, C, shall be fixed on a stiff, horizontal beam.

5.4.3 *Two Filaments*, B, with equal lengths,  $l$ , that connect the top plate with the clamping device. The ratio  $d_f:l$  shall be approximately 1:40. With the recommended dimension  $d_f=75$  mm, and the length,  $l=1000$  mm. The filaments shall be made of materials with low elongation and high strength (for example, tennis racket string and fishing line). The diameter of the filaments shall be not more than 1.0 mm.

## 6. Sampling and Conditioning

6.1 In order to ensure comparability, it is recommended that one of the following ski sizes be used if the data measured are to be published: 150, 165, or 185 cm. The ski size, measured by chord length (see Terminology F472 for the definition of chord length), should be within 3 cm of the value chosen. From these three sizes, choose the one that is most representative of the tested model.

6.2 All measurements shall be taken from a finished, manufactured ski without any mounted parts.

6.3 All measurements shall be taken from a ski that has been conditioned in a standard atmosphere 20/65 (ISO 554) (that is,

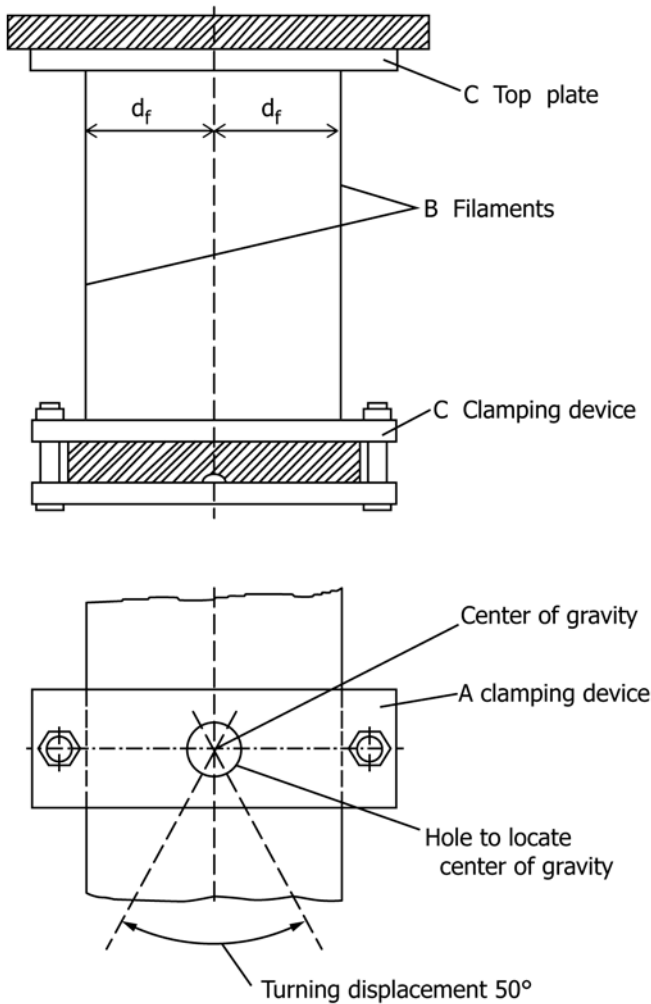

FIG. 1 Measuring Device

where:

- $a$  = length of the bar, m,
- $b$  = width of the bar, m, and
- $m$  = mass of the bar, kg.

7.4 Using this theoretical value and the measured value, the test equipment validation factor,  $c$ , can be determined from the following formula:

$$c = \frac{I_{th}}{I} \quad (2)$$

where:

- $I_{th}$  = theoretical polar moment of inertia, and
- $I$  = measured polar moment of inertia.

7.5 The test equipment validation factor,  $c$ , should fall within a range from 0.9 to 1.1. If  $c$  lies outside this range, the test equipment shall be checked and brought into conformity with this test method.

## 8. Procedure

8.1 Measure the mass of the ski with the weighing device (5.1).

8.2 Place the ski on the fulcrum (5.2) until it balances, to determine the center of gravity. Mark the center of gravity on the ski surface.

8.3 Mount the ski in the clamping device, A, (5.4.1) in such a way that the center of gravity mark is in the center of the hole in the top clamping fixture midway between the two filaments. The longitudinal center axis shall be perpendicular to a line drawn between the two filaments, B (see Fig. 1).

8.4 Let the ski come to rest suspended in the device. Eliminate any swinging motion. It is important that the test area be free of air movement, as this affects test accuracy.

8.5 With the hand, rotate the ski horizontally about its axis of gravity. Lateral displacement of the center of gravity exceeding 10 mm shall be avoided. The twist angle should be approximately 25°.

8.6 After displacing the ski, release it to swing freely around the perpendicular axis through the center of gravity. The time required for the ski to complete at least five cycles is recorded with the stopwatch (5.3). The time for one oscillation,  $T$ , is determined by the following formula:

$$T = \frac{\text{recorded time}}{n} \quad (3)$$

where:

- $n$  = number of cycles recorded.

## 9. Expression of Results

9.1 *Mass of the Ski*—Express the mass of the ski,  $m$ , in kilograms.

9.2 *Moment of Inertia of the Ski*—Express the moment of inertia of the ski,  $I$ , in kilogram-metres squared, using the following formula:

$$I = \left( \frac{T}{2\pi} \right)^2 mg \frac{d_f^2}{l} \quad (4)$$

the ski shall be placed in this atmosphere for at least 24 h prior to measurements being taken).

## 7. Calibration of Measuring Device

7.1 Differences in construction between the different measuring devices can lead to different measurement results, which deviate from the theoretical value of the polar moment of inertia. In order to reduce such deviations, it is recommended that a test equipment validation factor,  $c$ , be determined for each measuring device.

7.2 The test equipment validation factor is determined from the ratio of the calculated moment of inertia to the measured moment of inertia of a bar of steel with dimensions 1 to 8 by 20 to 30 by 1200 to 1700 mm. To ensure accurate measurements, it is important that the steel bar be level when placed in the test device. Any vertical displacement of the steel bar may alter calculation of the test device evaluation factor.

7.3 The theoretical moment of inertia,  $I_{th}$ , is calculated from the following formula:

$$I_{th} = \frac{m(a^2 + b^2)}{12} \quad (1)$$

where:

- $T$  = period of oscillation, s,  
 $m$  = mass of the finished manufactured ski without any ancillary parts, kg,  
 $g$  = acceleration due to gravity, m/s<sup>2</sup>,  
 $d_f$  = half-distance between the filaments measured on the top plate, m, and  
 $l$  = length of the filaments, m.

## 10. Tolerances

### 10.1 Measurement Tolerances:

Mass	±0.02 kg
Moment of inertia	±0.02 kg-m <sup>2</sup>

10.2 *Tolerances on Published Data*—If data are published by the manufacturer with reference to this test method, the following tolerances shall be observed:

Mass	10 %
Moment of inertia	10 %

*ASTM International takes no position respecting the validity of any patent rights asserted in connection with any item mentioned in this standard. Users of this standard are expressly advised that determination of the validity of any such patent rights, and the risk of infringement of such rights, are entirely their own responsibility.*

*This standard is subject to revision at any time by the responsible technical committee and must be reviewed every five years and if not revised, either reapproved or withdrawn. Your comments are invited either for revision of this standard or for additional standards and should be addressed to ASTM International Headquarters. Your comments will receive careful consideration at a meeting of the responsible technical committee, which you may attend. If you feel that your comments have not received a fair hearing you should make your views known to the ASTM Committee on Standards, at the address shown below.*

*This standard is copyrighted by ASTM International, 100 Barr Harbor Drive, PO Box C700, West Conshohocken, PA 19428-2959, United States. Individual reprints (single or multiple copies) of this standard may be obtained by contacting ASTM at the above address or at 610-832-9585 (phone), 610-832-9555 (fax), or service@astm.org (e-mail); or through the ASTM website (www.astm.org). Permission rights to photocopy the standard may also be secured from the Copyright Clearance Center, 222 Rosewood Drive, Danvers, MA 01923, Tel: (978) 646-2600; http://www.copyright.com/*

## 11. Report

11.1 Report the following information:

- 11.1.1 Reference to this test method,
- 11.1.2 Name of ski manufacturer,
- 11.1.3 Model designation of ski,
- 11.1.4 Nominal length of ski,
- 11.1.5 Registration number of ski, and
- 11.1.6 Any deviation from this test method, with an explanation of the reason for the deviation.

## 12. Precision and Bias

12.1 *Precision*—The precision of this test method is currently being determined.

12.2 *Bias*—There should be no bias in measurement of mass if the specification in 5.1 is followed. Bias in measurement of the moment of inertia is controlled by the test equipment evaluation factor described in Section 7.