



Standard Specification for Unused Rope with Special Electrical Properties¹

This standard is issued under the fixed designation F1701; the number immediately following the designation indicates the year of original adoption or, in the case of revision, the year of last revision. A number in parentheses indicates the year of last reapproval. A superscript epsilon (ϵ) indicates an editorial change since the last revision or reapproval.

1. Scope

1.1 This specification covers the requirements, sizes, construction, tests, and procedures for unused ropes for use by electrical utilities and related industries on energized lines operating at voltages higher than 1 kV.

1.2 This specification covers the minimum electrical, mechanical, and physical properties guaranteed by the manufacturer and the detailed procedures by which such properties are to be determined. The purchaser has the option to perform or have performed any of these tests in order to verify the guarantee. Claims for failure to meet the specification are subject to verification by the manufacturer.

1.3 The rope to which this specification applies is designed to be used in a clean and dry condition, on or near energized lines.

1.4 A margin of safety shall be allowed between the maximum voltage and working distances on which it is used and the test voltage and lengths at which it is tested.

1.5 It is common practice for the user of this type of equipment to prepare complete instructions and regulations to govern in detail the correct and safe use of such equipment.

1.6 The use and maintenance of this equipment is beyond the scope of this specification.

1.7 The values stated in SI units are to be regarded as the standard.

1.8 The following safety hazards caveat pertains only to the test method portion, Section 11, of this specification: *This standard does not purport to address all of the safety concerns, if any, associated with its use. It is the responsibility of the user of this standard to establish appropriate safety and health practices and determine the applicability of regulatory limitations prior to use.* The test levels used in this standard are for testing under laboratory conditions and are not to be regarded as safe use levels.

¹ This specification is under the jurisdiction of ASTM Committee F18 on Electrical Protective Equipment for Workers and is the direct responsibility of Subcommittee F18.35 on Tools & Equipment.

Current edition approved Jan. 1, 2012. Published February 2012. Originally approved in 1996. Last previous edition approved in 2005 as F1701-05. DOI: 10.1520/F1701-12.

2. Referenced Documents

2.1 ASTM Standards:²

C1500 Test Method for Nondestructive Assay of Plutonium by Passive Neutron Multiplicity Counting

D1125 Test Methods for Electrical Conductivity and Resistivity of Water

D4268 Test Methods for Testing Fiber Ropes (Withdrawn 2002)³

E4 Practices for Force Verification of Testing Machines

F711 Specification for Fiberglass-Reinforced Plastic (FRP) Rod and Tube Used in Live Line Tools

2.2 IEEE Standards:⁴

IEEE Std 4 Standard Techniques for High Voltage Testing

2.3 Other Standard:⁵

Cordage Institute CI-1301 Polypropylene Fiber Rope 3-Strand and 8-Strand Constructions (April 1999)

3. Terminology

3.1 *General*—The terms used in this specification are common to and well known by the industries that will be using them.

4. Ordering Information

4.1 Orders for rope under this specification should include the following information:

4.2 Manufacturer's designation of the rope.

4.3 *Length of Coil or Reel:*

4.3.1 *Lengths*—Each package shall be continuous throughout without splices or knots. Ends shall be taped, heat sealed, or served to prevent unraveling.

5. Physical Properties

5.1 *Hardness*—Refer to 11.5.

² For referenced ASTM standards, visit the ASTM website, www.astm.org, or contact ASTM Customer Service at service@astm.org. For *Annual Book of ASTM Standards* volume information, refer to the standard's Document Summary page on the ASTM website.

³ The last approved version of this historical standard is referenced on www.astm.org.

⁴ Available from Institute of Electrical and Electronics Engineers, Inc. (IEEE), 445 Hoes Ln., P.O. Box 1331, Piscataway, NJ 08854-1331.

⁵ Available from The Cordage Institute, 994 Old Eagle School Rd., Suite 1019, Wayne, PA 19087.

5.2 Diameter, Break Strength, and Elongation—Refer to 11.5.

6. Mechanical Properties

6.1 The primary mechanical property of rope is the breaking strength. Minimum breaking strengths, and associated nominal design characteristics (dimensions, mass, and acceptable variations) of ropes are available from manufacturer or the Cordage Institute.

7. Workmanship, Finish, and Appearance

7.1 All sizes of rope shall be evenly laid and well balanced in accordance with best rope making workmanship. Rope and strands shall be free from kinks, strand knots, and darting yarns or loose ends (inside yarns which project through cover yarns of strand at intervals along the rope).

8. Sampling and Number of Tests or Retests

8.1 Composition of Batch to be Sampled—Samples shall be taken from a homogeneous batch consisting of ropes of the same size and same dimensions and which have been subject to the same series of manufacturing operations and the same checking procedure.

8.2 Selecting the Samples—Take at random from the batch the minimum number of samples, *S*, obtained from the following equation:

$$S = 0.4 \sqrt{N}$$

where *N* = number of coils making up the batch. Where the calculated value of *S* is not a whole number, the number obtained shall be rounded to the nearest whole number. For example, 27.5 and 30.35 shall be rounded to 28 and 30, respectively. Where *S* < 1, take one sample length.

8.2.1 Specimen Selection Location—For testing of rope shipped in reel lengths, specimens shall be selected from each end. One specimen shall be selected from the outside end and one from the inside (drum) end. This will require a re-reeling of the rope.

8.3 Single-finished production runs of greater than 1828 m (6000 ft) tests shall be conducted at the beginning and end of the finished production length.

9. Specimen Preparation

9.1 Specimen preparation is included as a part of each test method. The ends of each rope specimen shall be heat sealed.

10. Recommended Working Load

10.1 Manufacturers furnishing rope under this specification shall specify a recommended maximum working load.

11. Test Methods and Performance Requirements

11.1 The ropes complying with these specifications shall undergo two different tests, electrical and mechanical/physical, and are to be termed “nonconductive” rope. Samples of rope selected in accordance with Section 8 from every production lot (single finished production length) shall be tested and each reel identified by lot (see 15.3).

11.1.1 The test sequence is (1) visual (Refer to Section 7; (2) dry electrical (Refer to 11.3); (3) wet electrical (Refer to 11.4); (4) mechanical/physical (Refer to 11.5).

11.2 **Caution**—It is recommended that the test apparatus be designed to afford the operator full protection in performance of his duties. Reliable means of deenergizing and grounding the high-voltage circuit shall be provided.

11.3 *Electrical Test Procedure Dry Test*—This is a dry specimen test to be used on new rope prior to wet test.

11.3.1 *Specimen for Test*—When selected in accordance with Section 8, the test specimen shall be at least 1.8 m (6 ft) long so that when the rope is held in a vertical position, there will be 1.0 m (3 ft) of rope free from knots, eyes, or splices (see Fig. 1).

11.3.2 *Handling of Specimen*—When the rope is handled, it shall always be outside the test footage (see Fig. 1).

11.3.3 *Electrodes:*

11.3.3.1 The electrodes shall be designed to shield out the majority of stray capacitive currents.

11.3.3.2 The electrodes and configuration shall be the same as those in Fig. 2, or the alternate setup in Fig. 3, which are similar to those specified in Specification F711 for testing FRP rod and tube (see Fig. 4). Electrical contact is made through clamps that fit snugly around the rope. The electrodes shall be mounted in a suitable frame like Fig. 2 to allow the suspension of the 305 mm (12 in.) ± 13 mm (½ in.) test section between the electrodes. A 4.5 kg (10 lb) weight shall be attached to the rope to maintain good electrical contact. (See Fig. 5 for clamp and plate details of Fig. 2).

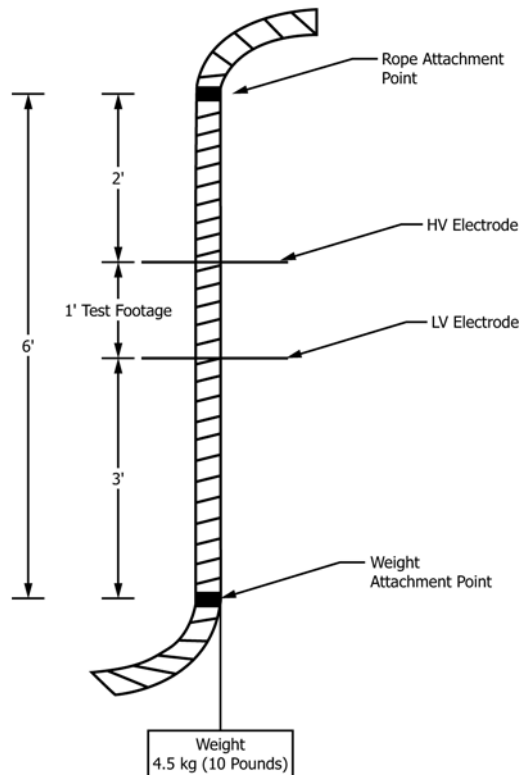
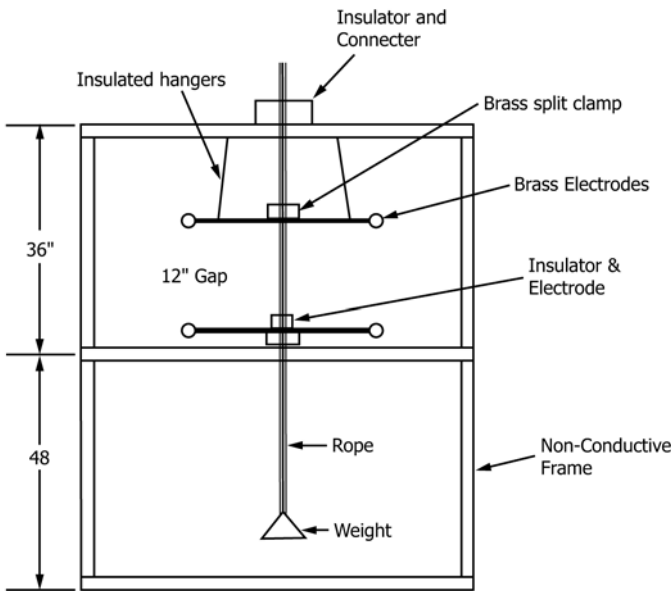

FIG. 1 Test Footage for Electrical Test



NOTE 1—Split Die Clamps modified to firmly clamp circumference of rope.

FIG. 2 Electrical Test Configuration

11.3.4 *Dry Test Leakage Readings*—The 60 Hz voltage shall be raised from 0 to 100 kV rms in not less than 5 nor more than 15 s. The voltage shall be held at 100 kV rms for 5 min. If at the end of 5 min the current is stable or dropping and has not exceeded 100 μ A at any time during the test, or flashed over, the specimen has passed the test. If at the end of 5 min the current is rising and not stable but does not exceed 100 μ A, or flashover, the test shall continue for an additional 25 min. If at the end of that time the rope has not flashed over and the current has stabilized at less than 100 μ A, the specimen has passed.

11.4 *Electrical Test Procedure-Wet Test:*

11.4.1 *Specimen for Test*—When selected in accordance with Section 8, the test specimen shall be at least 1.8 m (6 ft) long so that when the rope is held in a vertical position, there will be 1.0 m (3 ft) of rope free from knots, eyes, or splices (see Fig. 1).

11.4.2 *Handling of Specimen*—When the rope is handled, it shall always be outside the test footage (see Fig. 1).

11.4.3 *Electrodes:*

11.4.3.1 The electrodes shall be designed to shield out the majority of stray capacitive currents.

11.4.3.2 The electrodes and configuration shall be the same as those in Fig. 2, or the alternate setup in Fig. 3, which are similar to those specified in Specification F711 for testing FRP rod and tube (see Fig. 4). Electrical contact is made through clamps that fit snugly around the rope. The electrodes shall be mounted in a suitable frame like Fig. 2 to allow the suspension of the 305 mm (12 in.) \pm 13 mm ($\frac{1}{2}$ in.) test section between the electrodes. A 4.5 kg (10 lb) weight shall be attached to the rope to maintain good electrical contact. (See Fig. 5 for clamp and plate details of Fig. 2).

11.4.4 *Conditioning of Specimen:*

11.4.4.1 The weight of the preconditioned sample should be taken and recorded to the nearest milligram. Loss of hydrophobic coating could reduce weight saturation and should be considered a failure.

11.4.4.2 The entire rope specimen shall be subjected to 99 % RH for not less than 16 h, (at room temperature \pm 10°F). Samples should be coiled into coils of 10 to 12 in. diameter and hung in place with non-conductive ties (see Fig. 6).

11.4.4.3 The humidifier used should be a cool mist, ultra sonic style with no filtration and must be capable of producing a continuous water mist for 16 h with a rate of moisture production of approximately $\frac{1}{2}$ lb of mist per hour. The chamber humidity level must be 99 % or greater in 15 to 30 min after start.

11.4.5 *Water for Conditioning Mist*—The electrical resistivity of the water used for wetting shall meet the requirements of IEEE Standard 4, that is, 100 Ω m at ambient temperature \pm 5°C. The resistivity may be measured by using the test methods as described in Test Methods D1125.

11.4.6 *Removal of Specimen*—After the 16 h conditioning the samples should be removed from the box with care taken not to remove surface water, and immediately reweighed. Record difference in weight, that is, amount of water absorbed on test report.

11.4.6.1 Attach sample to the test setup per Fig. 2 or Fig. 3 immediately after weighing and within 5 min of removal from the wetting chamber.

11.4.7 *Wet Leakage Readings*—The 60 Hz voltage shall be raised from 1 to 50 kV rms in not less than 5 nor more than 15 s. The voltage shall be held at 50 kV rms for 5 min. If at the end of 5 min the current is stable or dropping and has not exceeded 250 μ A at any time during the test, or flashed over, the specimen has passed the test. If the sample does not exceed 250 μ A but is not stable or dropping in the first 5 min, the test is continued for an additional 5 min at which time the current must be stable or dropping. If at the end of the second 5 min, the current is not stable, has exceeded 250 μ A or has flashed over, the rope shall be reported as failed.

11.5 *Mechanical/Physical Test Procedures:*

11.5.1 *Specimen for Test*—The specification for the test specimen is provided in the details for each mechanical/physical test.

11.5.2 *Mass per Unit Length*—The procedure for determining the mass per unit length shall be in accordance with Test Methods D4268 or C1500.

11.5.3 *Diameter and Circumference* —The method for determining the nominal circumference and diameter shall be in accordance with Test Methods D4268 or C1500.

11.5.4 *Hardness*—Hardness shall be determined in accordance with Cordage Institute test methods.

11.5.5 *Breaking Strength*—The method for determining the breaking strength of the rope shall be in accordance with Test Methods D4268 or C1500.

11.5.6 *Elongation:*

11.5.6.1 Elongation shall be determined in accordance with Test Methods D4268.

11.5.6.2 This method covers the determination of elongation of new synthetic rope during its initial loading.

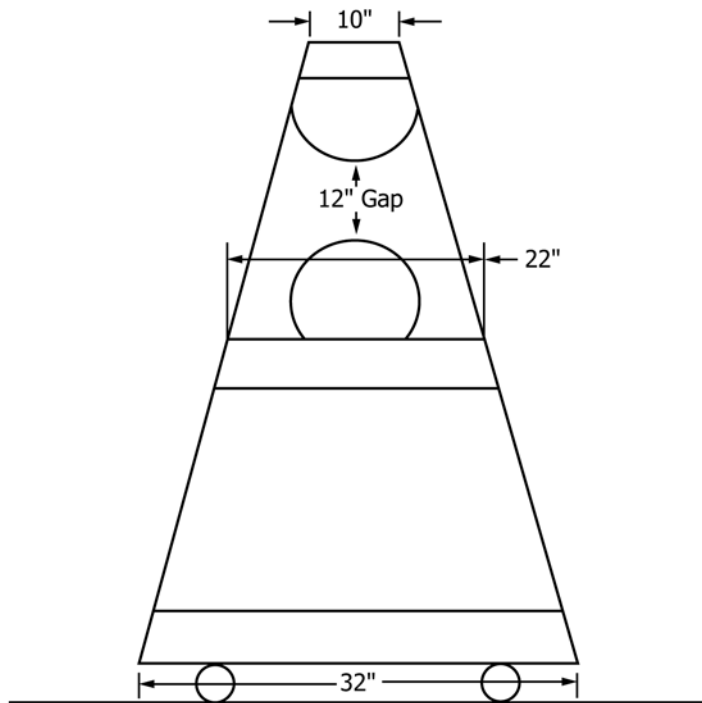
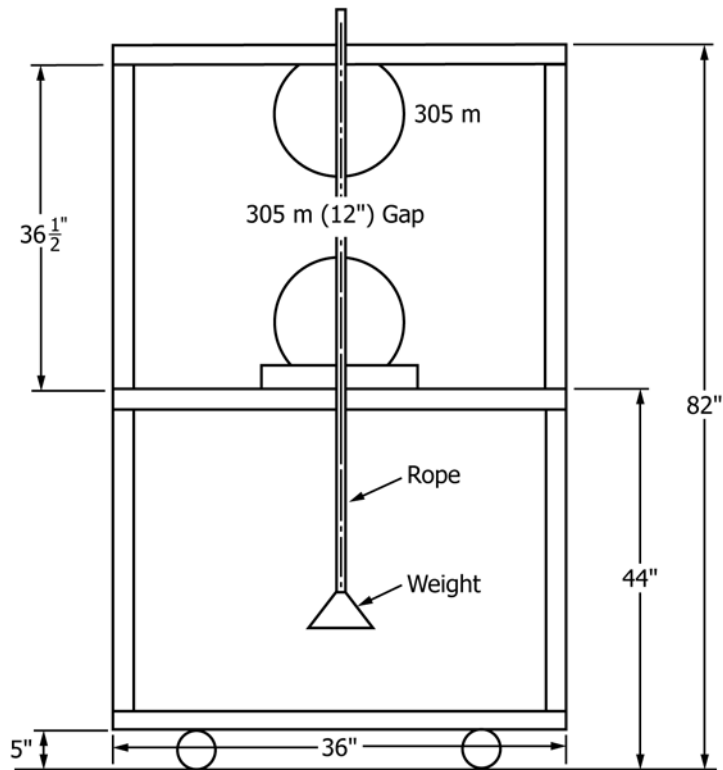

Alternate

FIG. 3 Electrical Test Configuration (Alternate)

11.6 Precision and Bias:

11.6.1 Each testing agency has the responsibility of judging the acceptability of its own results. The precision of the results is a function of the procedures, facilities utilized, as well as

compliance to the recommended industry state of the art practices. Reproducible analysis determinations by different users may be achieved only with identical facilities and trained conscientious personnel.

ELECTRICAL TEST CARRIED OUT DRY AND AFTER MOISTURE ABSORPTION

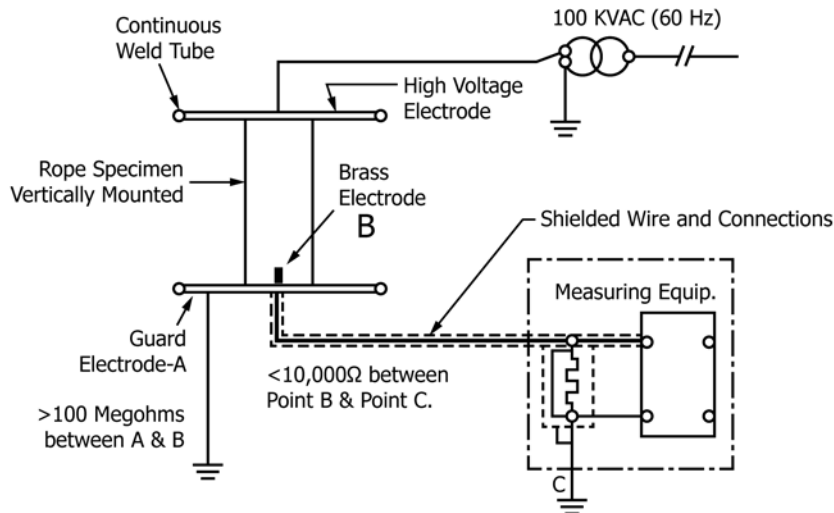

Typical A-C Test Set Up

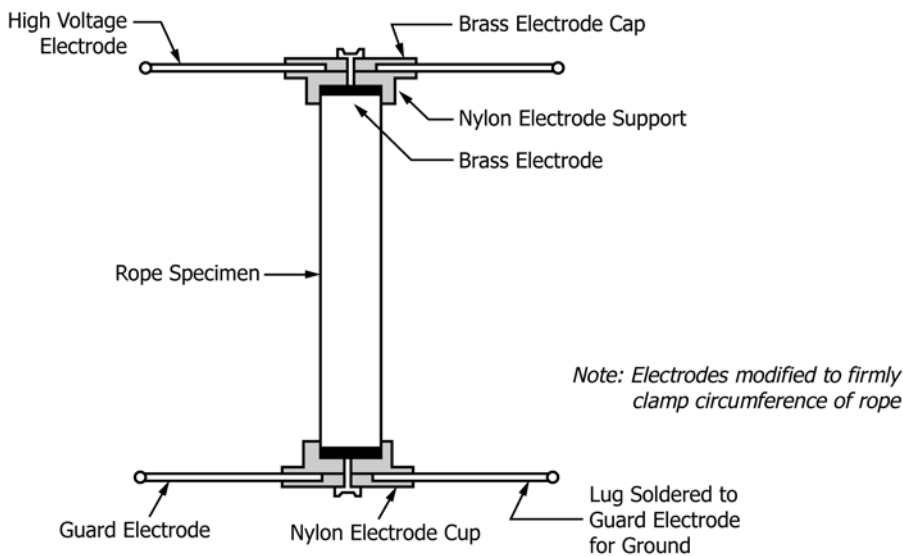

NOTE 1—Electrodes modified from F711 to firmly clamp circumference of rope.

FIG. 4 Reference Only: Specification F711 for Testing FRP Rod and Tube

11.6.2 Electrical Test Equipment:

11.6.2.1 The test equipment shall be of such a quality that the applied voltage shall be within $\pm 2\%$ of the specified test voltage. The voltage shall be recorded continuously at a frequency of at least once per second for the entire duration of the electrical testing.

11.6.2.2 The current-measuring device shall be of such a quality that the current measured shall be accurate to within $\pm 2\%$ of scale reading. The current shall be recorded continuously at a frequency of at least once per second for the entire duration of the electrical testing.

11.6.3 Mechanical test equipment shall meet Practices E4.

11.6.4 *Standard Atmospheric Conditions*—The atmospheric condition shall be substantially at a temperature of $22 \pm 5^\circ\text{C}$ ($72 \pm 9^\circ\text{F}$) and relative humidity of 35 % minimum and negligible air movement.

12. Rejection and Rehearing

12.1 Material that fails to conform to the requirements of this specification may be rejected. Rejection should be reported to the producer or supplier promptly and in writing. In case of dissatisfaction with the results of the test, the producer or supplier may make claim for a rehearing.

Upper and Lower Electrode Plates

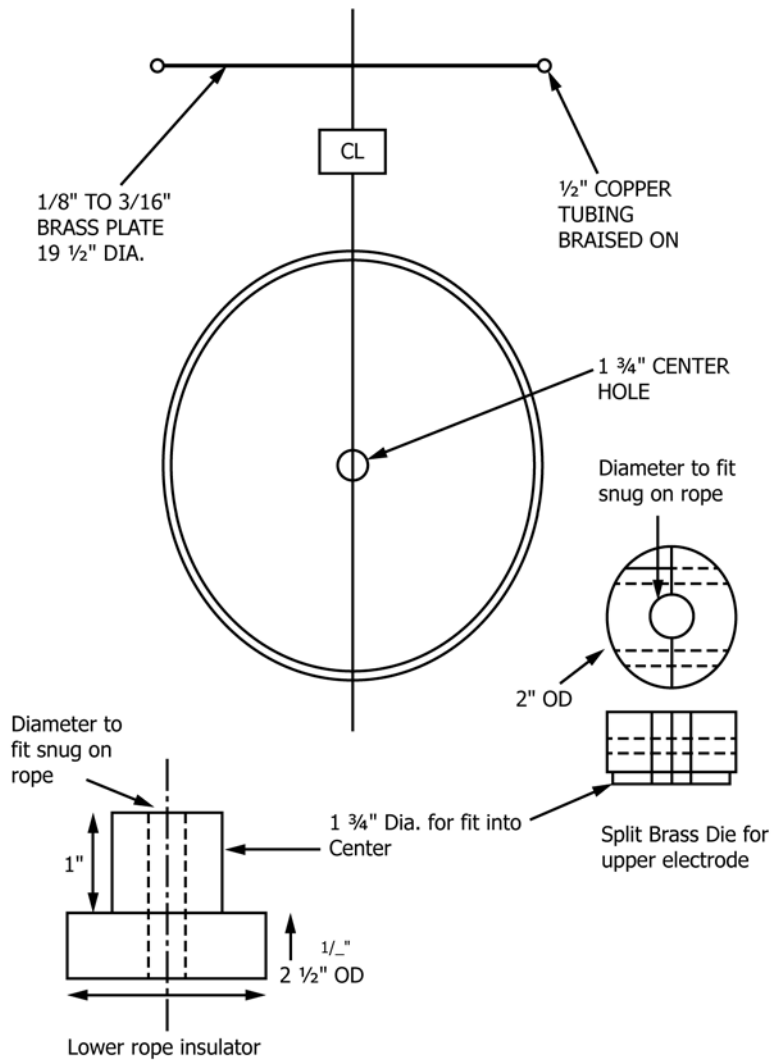

FIG. 5 High Voltage Electrodes, Split Die Clamps and Lower Rope Insulator Dimensions

13. Certification

13.1 When specified in the purchase order or contract, the purchaser shall be furnished certification that samples representing each lot have been either tested or inspected as directed in this specification and the requirements have been met.

13.2 When specified in the purchase order or contract, a report of the test results shall be furnished that includes a graph of the electrical testing results.

14. Product Marking

14.1 A marker strip shall be used to identify the manufacturer and year of manufacture.

14.2 The marker strip material shall not compromise or degrade the dielectric characteristics of the rope.

15. Packaging and Package Marking

15.1 Exterior covering shall be furnished to prevent chafing or damage to rope during transit.

15.2 The manufacturer's packaging shall be acceptable unless specific request is made by the purchaser.

15.3 Each package shall be tagged or stenciled with weatherproof marking referencing this specification and, as a minimum, stating manufacturer's designation of rope, diameter, length, net and gross weight, manufacturer, and lot number.

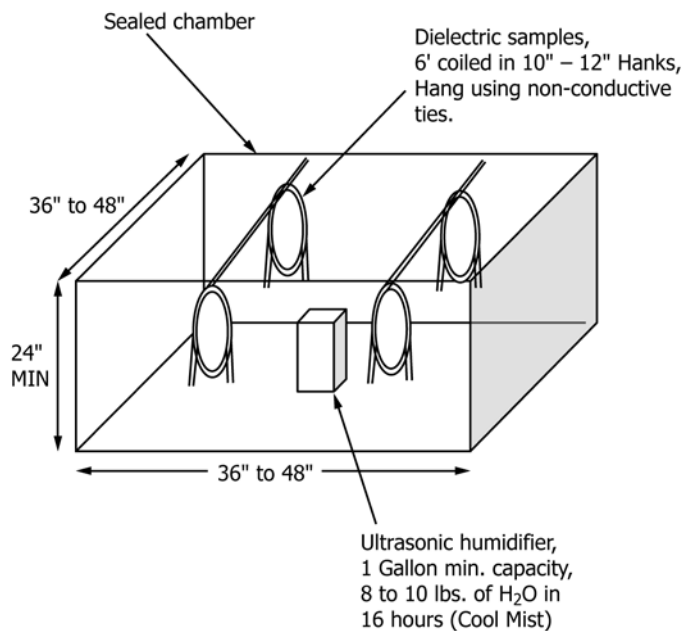

FIG. 6 Humidity (Wetting Chamber)

ASTM International takes no position respecting the validity of any patent rights asserted in connection with any item mentioned in this standard. Users of this standard are expressly advised that determination of the validity of any such patent rights, and the risk of infringement of such rights, are entirely their own responsibility.

This standard is subject to revision at any time by the responsible technical committee and must be reviewed every five years and if not revised, either reapproved or withdrawn. Your comments are invited either for revision of this standard or for additional standards and should be addressed to ASTM International Headquarters. Your comments will receive careful consideration at a meeting of the responsible technical committee, which you may attend. If you feel that your comments have not received a fair hearing you should make your views known to the ASTM Committee on Standards, at the address shown below.

This standard is copyrighted by ASTM International, 100 Barr Harbor Drive, PO Box C700, West Conshohocken, PA 19428-2959, United States. Individual reprints (single or multiple copies) of this standard may be obtained by contacting ASTM at the above address or at 610-832-9585 (phone), 610-832-9555 (fax), or service@astm.org (e-mail); or through the ASTM website (www.astm.org). Permission rights to photocopy the standard may also be secured from the Copyright Clearance Center, 222 Rosewood Drive, Danvers, MA 01923, Tel: (978) 646-2600; <http://www.copyright.com/>