



Standard Specification and Test Method for Rear-Mounted Bicycle Child Carriers¹

This standard is issued under the fixed designation F1625; the number immediately following the designation indicates the year of original adoption or, in the case of revision, the year of last revision. A number in parentheses indicates the year of last reapproval. A superscript epsilon (ϵ) indicates an editorial change since the last revision or reapproval.

1. Scope

1.1 This specification covers child carriers that mount to the rear of bicycles in order to transport children or accessory loads with a maximum weight of 18 kg (40 lb). This specification does not apply to child carriers that mount in front of the handlebars, or to the top tube, head tube, or behind the handlebars in front of the rider.

NOTE 1—In the instructions, the manufacturer must warn the rider that a load added to the bicycle will lessen the stability and alter the riding characteristics of the bicycle. This complication is particularly important when riding with children who are near the high end of the weight range.

1.2 The following safety hazards caveat pertains only to the test method portions, Sections 5, 6, and 7, of this specification: *This standard does not purport to address all of the safety concerns, if any, associated with its use. It is the responsibility of the user of this standard to establish appropriate safety and health practices and determine the applicability of regulatory limitations prior to use.*

2. Referenced Documents

2.1 ASTM Standards:²

[B117 Practice for Operating Salt Spray \(Fog\) Apparatus](#)

2.2 ISO Standards:

[ISO/TC149/SC1 N368, Luggage Carriers for Bicycles³](#)

[ISO/TC149/SC1 N369, Child Seats for Bicycles, Concepts, Safety Requirements and Testing³](#)

2.3 Government Standards:

[Title 16, Code of Federal Regulations, Part 1500.44, Flammability⁴](#)

[Title 16, Code of Federal Regulations, Part 1500.48, Sharp Points⁴](#)

[Title 16, Code of Federal Regulations, Part 1500.49, Sharp Edges⁴](#)

[16 CFR 1501, Small Parts⁴](#)

[16 CFR 1303, Lead in Coatings⁴](#)

3. Terminology

3.1 Definitions:

3.1.1 *bicycle child carrier*—a seating device, the shape of which is adapted to the seated position of a child and mounts to the rear of the bicycle, which keeps the child in a comfortable position during the ride.

4. Requirements

4.1 *General*—Child carriers shall be designed and manufactured in such a way that components with which the child or rider come into contact do not cause injuries during normal use, or when used in accordance with the manufacturer's instructions. Surfaces must be free from burrs, sharp edges, and points; if such are present they must be covered by protective coverings. No openings with which the child's hands can come in contact shall have dimensions larger than 6 mm (0.236 in.) but also smaller than 13 mm (0.512 in.), that is, holes with dimensions between 0.236 and 0.512 in. (6 and 13 mm) are forbidden. Child carriers must be equipped with a rear reflector. The manufacturer must warn the rider that a load added to the bicycle will lessen the stability and alter the riding characteristics of the bicycle.

4.2 Structure:

4.2.1 *Assembly*—When assembled in accordance with the instructions provided by the manufacturer, the seat components must be firmly joined and fixed.

4.2.2 *Equipment*—Child carriers shall be equipped with the following equipment:

4.2.2.1 Footrests,

4.2.2.2 Backrest,

4.2.2.3 Armrests (that may be extensions of the sides of the seat surface),

4.2.2.4 Protective devices that prevent contact of hands and feet with moving or movable components of the bicycle which could cause injury, and

¹ This specification is under the jurisdiction of ASTM Committee F08 on Sports Equipment, Playing Surfaces, and Facilities and is the direct responsibility of Subcommittee F08.10 on Bicycles.

Current edition approved Nov. 1, 2012. Published November 2012. Originally approved in 1995. Last previous edition approved in 2008 as F1625 – 00 (2008). DOI: 10.1520/F1625-00R12.

² For referenced ASTM standards, visit the ASTM website, www.astm.org, or contact ASTM Customer Service at service@astm.org. For *Annual Book of ASTM Standards* volume information, refer to the standard's Document Summary page on the ASTM website.

³ Available from American National Standards Institute (ANSI), 25 W. 43rd St., 4th Floor, New York, NY 10036, <http://www.ansi.org>.

⁴ Available from U.S. Government Printing Office Superintendent of Documents, 732 N. Capitol St., NW, Mail Stop: SDE, Washington, DC 20401, <http://www.access.gpo.gov>.

4.2.2.5 Belt or other capturing devices designed to restrain the child from standing in or leaving the carrier. Buckles, if used, must be difficult for the child passenger to open.

4.2.3 *Attachment*—The attachment process for connecting the seat portion of the carrier either to dedicated mounting hardware or to a luggage carrier, and attachment of the mounting hardware or the luggage carrier to the bicycle frame, shall be of a simple and secure procedure. If tools are required for mounting, mounting must be accomplished with common household tools, and must offer no reasonable opportunity of incorrect mounting.

4.2.4 *Test Criteria*—After testing in accordance with Sections 5 and 6 of this specification the child carrier shall show no visible signs of fracture, nor any deformation or displacement that would impair the function of the child carrier or the bicycle, as defined by the allowable amounts set forth in Sections 5 and 6.

4.3 *Security of Seat Assembled to Bicycle:*

4.3.1 If the means of attachment of the carrier to the bicycle is within easy reach of the child, and also is of a type that the child may be able to loosen, then there shall be a secondary device to restrict movement of the carrier, either by providing an additional and independent attachment or by ensuring that loosening the primary attachment will not fully release the connection.

4.3.2 Child carriers that do not attach directly to the bicycle seat tube, such as rack-mounting models, shall have an additional attachment device connecting the seat portion either to a frame tube or to the saddle pillar, with sufficient strength to limit rearward movement of the seat.

4.4 *Dimensions:*

4.4.1 Dimensions of the interior of the carrier seating area shall be adequate for the seated child at the upper range of the weight limitation.

4.4.2 The backrest must have a minimum height of 350 mm (13.8 in.).

4.4.3 The armrests must be high enough to keep the child stable in lateral directions.

4.5 *Materials:*

4.5.1 Plastics or other synthetic materials, if used, shall be stabilized against ultraviolet radiation and resistant to ozone.

4.5.2 The carrier shall be protected against corrosion and tested in accordance with salt spray test defined in Practice B117, for a period of 96 h. Tested components shall show no visible evidence of corrosion or deterioration which could jeopardize structural integrity of the entire assembly. The tested unit shall continue to operate in accordance with the manufacturer’s written instructions.

5. Environmental Temperature Tests

5.1 *General*—Perform the tests in this section on all carriers to determine whether there are any adverse affects on the strength and function of the carrier under conditioned environments.

5.1.1 Conduct these environmental temperature tests prior to the dynamic load tests that follow.

5.2 *Resistance to High Temperatures:*

5.2.1 Store the carrier for at least 4 h, but not more than 24 h at a temperature of $50 \pm 3^\circ\text{C}$ ($122 \pm 5^\circ\text{F}$).

5.2.2 Examine the carrier for damage or distortion that could affect the safety or function of the carrier.

5.2.3 Damage or distortion that could affect the safety or function of the carrier constitutes failure of the test.

5.3 *High-Temperature Drop Test:*

5.3.1 Store the carrier for at least 4 h, but not more than 24 h, at a temperature of $50 \pm 3^\circ\text{C}$ ($122 \pm 5^\circ\text{F}$).

5.3.2 Remove the carrier from the hot environment and mount it on the test fixture depicted in Fig. 1 that holds the lowest point of the underside of the seating area of the carrier shell at a height of 1.00 ± 0.01 m (39.37 ± 0.39 in.) above a concrete floor. The bottom of the fixture has a pivoting device that allows the fixture to rotate until it contacts the floor. The mass of the drop arm of the fixture is $11 + 0.5 - 0$ kg ($24 + 1.0 - 0$ lb). Within 1 min after removal from the conditioned environment, release the carrier under gravity from rest to one side or the other onto a flat concrete surface, as if the bicycle to which it was mounted fell over.

5.3.3 Examine the carrier for damage or distortion that could affect the safety or function of the carrier.

5.3.4 Damage or distortion that could affect the safety or function of the carrier constitutes failure of the test.

5.4 *Low-Temperature Resistance:*

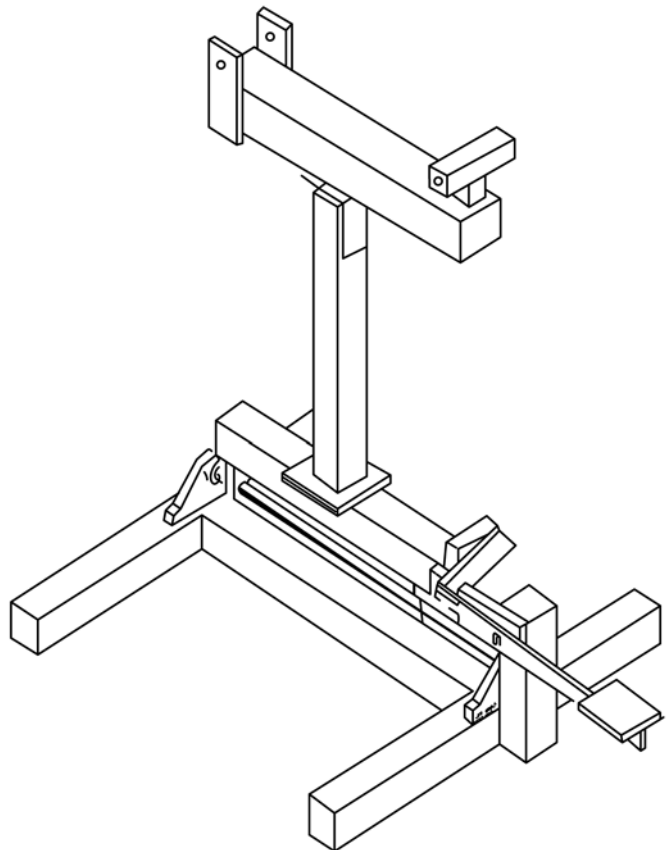

NOTE 1—Figures are intended only to indicate one possible configuration for test fixtures and are not intended to be adequate for fabrication.

FIG. 1 Child Carrier Drop Test Fixture

5.4.1 Store the carrier for at least 4 h, but not more than 24 h, at a temperature of $-7 \pm 3^{\circ}\text{C}$ ($20 \pm 5^{\circ}\text{F}$).

5.4.2 Examine the carrier for damage or distortion that could affect the safety or function of the carrier.

5.4.3 Damage or distortion that could affect the safety or function of the carrier constitutes failure of the test.

5.5 *Low-Temperature Drop Test:*

5.5.1 Store the carrier for at least 4 h, but not more than 24 h, at a temperature of $-7 \pm 3^{\circ}\text{C}$ ($20 \pm 5^{\circ}\text{F}$).

5.5.2 Remove the carrier from the cold environment and mount it on the test fixture depicted in Fig. 1 that holds the lowest point of the underside of the seating area of the carrier shell at a height of 1.00 ± 0.01 m (39.37 ± 0.39 in.) above a concrete floor. The bottom of the fixture has a pivoting device that allows the fixture to rotate until it contacts the floor. The mass of the drop arm is $11 + 0.5 - 0$ kg ($24 + 1.0 - 0$ lb). Within 1 min after removal from the conditioned environment, release the carrier under gravity from rest to one side or the other onto a flat concrete surface, as if the bicycle to which it was mounted fell over.

5.5.3 Examine the carrier for damage or distortion that could affect the safety or function of the carrier.

5.5.4 Damage or distortion that could affect the safety or function of the carrier constitutes failure of the test.

6. Strength: Dynamic Load Tests

6.1 *Purpose*—There are three reasons for the dynamic load tests: (a) to determine whether fasteners become loosened by vibration; (b) to determine whether the carrier shifts in position during the tests; and (c) to determine whether damage or cracks occur anywhere in the carrier or the mounting system as a result of the tests.

6.2 *Vibration Test:*

6.2.1 *General Test Method:*

6.2.1.1 Mount the carrier securely to the fixture depicted in Fig. 2. The fixture is part of an apparatus that is capable of providing the motion described in 6.2.2 and 6.2.4.

6.2.1.2 Load the carrier with a system that has a mass of $18 + 1 - 0$ kg ($40 + 2 - 0$ lb), such as sand bags. The center of gravity of the added mass shall be no more than 152 mm (6.0 in.) above the bottom surface of the seating area. Secure the load with the retention system provided with the carrier. Mark the position of the carrier on the fixture, and the positions of the closures on all straps.

6.2.2 *Vertical Vibration Test*—The fixture depicted in Fig. 2 is set up so that the total vertical movement at the top of the vertical tube is 10 mm (0.39 in.), consisting of 5 mm up and 5 mm down from the central position in non-sinusoidal motion. The “bump” is an instantaneous rise and instantaneous fall from a 1-in. (25-mm) wide cleat. An actual 19-in. (480-mm) road bicycle frame or a 16-in. (410-mm) mountain bicycle frame can be attached to the mounting structure indicated in the figure. Adjust the motor so that the rate of complete vertical cycles is 7 Hz (420 cycles per minute). Continue the test for a total of 42 000 complete vertical cycles.

6.2.3 *Inspection*—Inspect the carrier for damage, deformation, and displacement. Displacement at any attachment point where the carrier is attached to the bicycle shall not

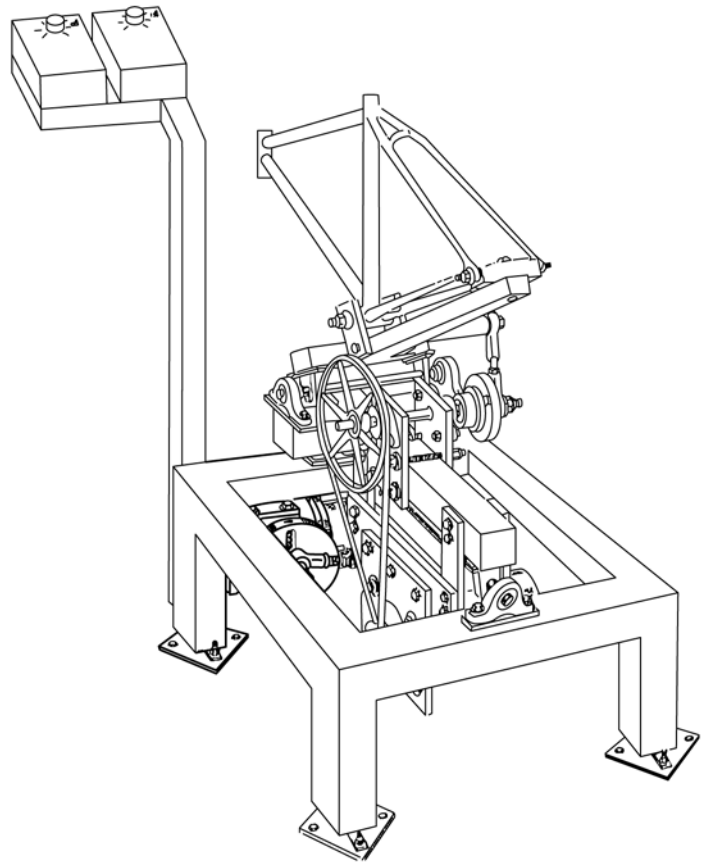

NOTE 1—Figures are intended only to indicate one possible configuration for test fixtures and are not intended to be adequate for fabrication.

FIG. 2 Child Carrier Vibration and Lateral Sway Test Fixture

exceed 10 mm (0.394 in.), and no cracking or splitting of any carrier components shall have occurred.

6.2.4 *Lateral Vibration Test*—In this test, tilt the carrier with the $18 + 1 - 0$ -kg ($40 + 2 - 0$ -lb) load sinusoidally from side to side, simulating a bicyclist riding up a steep hill that requires the rider to stand and pedal vigorously. The fixture has a system that tilts it alternately, in sinusoidal fashion, from center to 8° on either side of center, at a frequency of 0.5 Hz (30 cycles/min). The fixture is of such size that the lowest level of the carrier seat is 800 mm (31.5 in.) above the rotational axis. Tilt the system through 50 000 complete cycles.

6.2.5 *Inspection*—Inspect the carrier for damage, deformation, and displacement. Displacement at any attachment point where the carrier is attached to the bicycle shall not exceed 10 mm (0.394 in.). No cracking or splitting of any carrier components shall have occurred.

7. Additional Test Criteria

7.1 *Flammability*—All components of the carrier shall meet the flammability requirements defined in Title 16, Code of Federal Regulations, Part 1500.44.

7.2 *Sharp Points*—All components of the carrier shall meet the requirements of Title 16, Code of Federal Regulations, Part 1500.48, regarding sharp points that could cause puncture or laceration injuries.

7.3 *Sharp Edges*—All components of the carrier shall satisfy the requirements of Title 16, Code of Federal Regulations, Part 1500.49, regarding sharp edges that could cause laceration or avulsion injuries.

7.4 *Ambient Drop Test:*

7.4.1 Place the carrier in ambient conditions for a period of at least 4 h.

7.4.2 Mount the carrier on the test fixture depicted in Fig. 1 that holds the lowest point of the underside of the seating area of the carrier shell at a height of 1.00 ± 0.01 m (39.37 ± 0.39 in.) above a concrete floor. The bottom of the fixture has a pivoting device that allows the fixture to rotate until it contacts the floor. The mass of the drop arm of the fixture is $11 + 0.5 - 0$ kg ($24 + 1.0 - 0$ lb). Release the carrier under gravity from rest, rotating on the fixture until the upper back of the carrier strikes the floor.

7.4.3 Examine the carrier for damage or distortion that could affect the safety or function of the carrier.

7.4.4 Damage or distortion that could affect the safety or function of the carrier constitutes failure.

7.5 *Retention System Pull Test:*

7.5.1 Attach a representative retention system, separated from the carrier, to a device that pulls at the ends of the system. Orient a 16-in. (410-mm) section of the retention system so that the fastening device is between the pulling ends.

7.5.2 The ends of the 16-in. (410-mm) section of the retention system are pulled apart with a static load of $45 + 2.0 - 0$ kg ($100 + 4.4 - 0$ lb) for a period of 1 min.

7.5.3 The retention system must remain intact with no loss or impairment of function. Elongation of the straps by stretch and slippage shall not exceed 30 mm (1.18 in.).

7.6 *Retention System Security Test:*

7.6.1 Test a representative retention system attached to a child carrier seat with a system measuring tension load to determine its ability to stay on the seat. Orient the retention system so that the pull direction is perpendicular to the child carrier at the attachment point.

7.6.2 Pull the retention system at each point where it anchors to the seat with a force of $45 + 2.0 - 0$ kg ($100 + 4.4 - 0$ lb).

7.6.3 The retention system must remain intact and the anchor point on the seat shall not be damaged beyond functional limits.

8. Marking

8.1 *General:*

8.1.1 The carrier shall be durably marked, in a language recognized in the country where it is sold, with the following information. Position the information in a location that is obvious and readily seen on a completely assembled carrier. Stickers, if used, must not peel, degrade or fade to the point of being difficult to read upon completion of the above tests:

8.1.1.1 The 40-lb (18-kg) maximum weight of child that may be transported in the carrier,

8.1.1.2 The name or symbol of the manufacturer,

8.1.1.3 The uncoded date of manufacture,

8.1.1.4 Warning that a load added to the bicycle will lessen the stability and alter the riding characteristics of the bicycle,

8.1.1.5 Caution not to ride in inclement or hazardous conditions, including temperatures below freezing that could cause the child to suffer frostbite,

8.1.1.6 Caution that the rider and the child should wear helmets that have been approved to nationally recognized standards, and

8.1.1.7 Caution that only children who are able to hold their head upright while wearing a bicycle helmet (approximately one year old) should be passengers in a child carrier. A pediatrician should evaluate any child who is of questionable developmental age.

9. Instructions

9.1 *General*—The carrier shall be supplied with instructions in English for mounting to the bicycle or to the appropriate luggage rack, or both, and for correct use of the carrier. These instructions shall also be presented in a recognized language of the country where the carrier is sold, and shall include at least the information specified in 9.2.

9.2 *Specific Instructions:*

9.2.1 The following items shall be explained in the manufacturer's instructions that accompany the product, and shall be headed by a "CAUTION" statement to indicate their importance. They shall be physically attached to the product as it is removed from the shipping carton, or enclosed in a sealed bag with carrier components, to ensure that the consumer is aware of them before using the product:

9.2.1.1 How and where the carrier is to be attached to the bicycle.

9.2.1.2 The bicycle to which the carrier is attached must be in good working order, of a type appropriate for the additional load, and of proper size and adjustment for the rider. This instruction should include advice to check the information supplied with the bicycle, or obtain information from the manufacturer or supplier of the bicycle.

9.2.1.3 Tighten fasteners securely, and check them frequently.

9.2.1.4 Do not carry a child who is too young to sit comfortably and independently in the carrier. (A pediatrician should be consulted before any child younger than one year is carried.)

9.2.1.5 Ensure initially, and check from time to time, that the child's weight does not exceed the load limit of the carrier.

9.2.1.6 Additional luggage or accessories should not be attached to the carrier, as they may exceed the load limit, and may lessen stability. Total load limit for the carrier is 18 kg (40 lb).

9.2.1.7 Make no modifications to the carrier.

9.2.1.8 Do not allow any of the child's body, clothing, shoe laces, or toys to come in contact with moving parts of the bicycle.

9.2.1.9 Always attach the retention system snugly around the child.

9.2.1.10 When no child is being carried, fasten the retention system buckles so the straps do not hang loosely.

9.2.1.11 Ensure the rider and child are wearing approved bicycle helmets.

9.2.1.12 Never ride in inclement or hazardous conditions.

9.2.1.13 The load of a child carrier may lessen the stability and alter the riding characteristics of the bicycle, particularly regarding steering and braking.

9.2.1.14 Never leave the child unattended in the carrier.

9.2.1.15 Never leave the child in a carrier with the bicycle supported only by a kickstand.

9.2.1.16 A rear reflector that complies with CPSC regulations must be visible whether the carrier is on the bicycle or not.

9.2.1.17 Before each ride, ensure the mounted carrier does not interfere with braking, pedaling, or steering of the bicycle.

9.2.1.18 Never ride the bicycle at night without adequate lighting.

9.2.1.19 Always remove the carrier from the bicycle when the bicycle is being transported on a motor vehicle. This is necessary because the force of the high wind on the carrier may degrade or damage the carrier to the point that it will not perform reliably.

9.2.1.20 Presence of a child carrier on a bicycle may require alteration of the method used by the rider to mount or dismount the bicycle. Care must be taken whenever the rider gets on or off the bicycle.

9.2.1.21 **WARNING!** Failure to comply with the manufacturer's instructions can lead to serious injury or death of the passenger/rider!

10. Keywords

10.1 bicycle; child carrier; rear-mounted

ASTM International takes no position respecting the validity of any patent rights asserted in connection with any item mentioned in this standard. Users of this standard are expressly advised that determination of the validity of any such patent rights, and the risk of infringement of such rights, are entirely their own responsibility.

This standard is subject to revision at any time by the responsible technical committee and must be reviewed every five years and if not revised, either reapproved or withdrawn. Your comments are invited either for revision of this standard or for additional standards and should be addressed to ASTM International Headquarters. Your comments will receive careful consideration at a meeting of the responsible technical committee, which you may attend. If you feel that your comments have not received a fair hearing you should make your views known to the ASTM Committee on Standards, at the address shown below.

This standard is copyrighted by ASTM International, 100 Barr Harbor Drive, PO Box C700, West Conshohocken, PA 19428-2959, United States. Individual reprints (single or multiple copies) of this standard may be obtained by contacting ASTM at the above address or at 610-832-9585 (phone), 610-832-9555 (fax), or service@astm.org (e-mail); or through the ASTM website (www.astm.org). Permission rights to photocopy the standard may also be secured from the Copyright Clearance Center, 222 Rosewood Drive, Danvers, MA 01923, Tel: (978) 646-2600; <http://www.copyright.com/>