



Standard Test Method for Microbial Ranking of Porous Packaging Materials (Exposure Chamber Method)¹

This standard is issued under the fixed designation F1608; the number immediately following the designation indicates the year of original adoption or, in the case of revision, the year of last revision. A number in parentheses indicates the year of last reapproval. A superscript epsilon (ϵ) indicates an editorial change since the last revision or reapproval.

1. Scope

1.1 This test method is used to determine the passage of airborne bacteria through porous materials intended for use in packaging sterile medical devices. This test method is designed to test materials under conditions that result in the detectable passage of bacterial spores through the test material.

1.1.1 A round-robin study was conducted with eleven laboratories participating. Each laboratory tested duplicate samples of six commercially available porous materials to determine the Log Reduction Value (LRV) (see calculation in Section 12). Materials tested under the standard conditions described in this test method returned average values that range from LRV 1.7 to 4.3.

1.1.2 Results of this round-robin study indicate that caution should be used when comparing test data and ranking materials, especially when a small number of sample replicates are used. In addition, further collaborative work (such as described in Practice E691) should be conducted before this test method would be considered adequate for purposes of setting performance standards.

1.2 This test method requires manipulation of microorganisms and should be performed only by trained personnel. The U.S. Department of Health and Human Services publication *Biosafety in Microbiological and Biomedical Laboratories* (CDC/NIH-HHS Publication No. 84-8395) should be consulted for guidance.

1.3 The values stated in SI units are to be regarded as standard. No other units of measurement are included in this standard.

1.4 *This standard does not purport to address all of the safety concerns, if any, associated with its use. It is the responsibility of the user of this standard to establish appropriate safety and health practices and determine the applicability of regulatory limitations prior to use.*

¹ This test method is under the jurisdiction of ASTM Committee F02 on Flexible Barrier Packaging and is the direct responsibility of Subcommittee F02.15 on Chemical/Safety Properties.

Current edition approved May 1, 2016. Published June 2016. Originally approved in 1995. Last previous edition approved in 2009 as F1608 – 00 (2009). DOI: 10.1520/F1608-16.

2. Referenced Documents

2.1 *ASTM Standards*:²

E691 Practice for Conducting an Interlaboratory Study to Determine the Precision of a Test Method

3. Terminology

3.1 *Definitions*:

3.1.1 *porous packaging material, n*—a material used in medical packaging which is intended to provide an environmental and biological barrier, while allowing sufficient air flow to be used in gaseous sterilization methods (for example, ethylene oxide, steam, gas plasma).

4. Summary of Test Method

4.1 Samples of porous materials are subjected to an aerosol of *Bacillus atrophaeus* spores within an exposure chamber. Spores which pass through the porous sample are collected on membrane filters and enumerated. The LRV is calculated by comparing the logarithm of the number of spores passing through the porous material with the logarithm of the microbial challenge.

4.2 *Standard Set of Conditions*—This test method specifies a standard set of conditions for conducting the exposure chamber test method. A standard set of conditions is required to enable evaluation of materials between laboratories. The conditions stated in this test method were chosen for several reasons. First, it is difficult to maintain an aerosol of spores over long periods of time. (Also, if the spore challenge time is long, the cost of the test increases). Second, to determine the differences between materials, it is necessary to test the materials under conditions which allow passage of bacterial spores. If a material does not allow any passage of spores, all that can be stated is that it has better resistance to penetration than the severity of the challenge conditions. Third, it is necessary to have a large spore challenge level to be able to detect the passage of spores through the entire range of

² For referenced ASTM standards, visit the ASTM website, www.astm.org, or contact ASTM Customer Service at service@astm.org. For *Annual Book of ASTM Standards* volume information, refer to the standard's Document Summary page on the ASTM website.

commercially available porous packaging materials. The standard conditions stated in this test method are based upon these factors. (Additional information may be found in the References section). However, since many factors influence the determination of an appropriate porous material (outlined in 5.1.1 – 5.1.4), each user may modify these conditions (that is, bacterial challenge, time, flow rate) after first conducting studies at the specified standard conditions. The standard set of target parameters for conducting the test method are as follows:

4.2.1 *Flow Rate Through Sample*—2.8 L/min.

4.2.2 *Exposure Time*— 15 min.

4.2.3 *Target Microbial Challenge* — 1×10^6 colony forming units (CFU)/sample port.

5. Significance and Use

5.1 The exposure-chamber method is a quantitative procedure for determining the microbial-barrier properties of porous materials under the conditions specified by the test. Data obtained from this test is useful in assessing the relative potential of a particular porous material in contributing to the loss of sterility to the contents of the package versus another porous material. This test method is not intended to predict the performance of a given material in a specific sterile-packaging application. The maintenance of sterility in a particular packaging application will depend on a number of factors, including, but not limited to the following:

5.1.1 The bacterial challenge (number and kinds of microorganisms) that the package will encounter in its distribution

and use. This may be influenced by factors such as shipping methods, expected shelf life, geographic location, and storage conditions.

5.1.2 The package design, including factors such as adhesion between materials, the presence or absence of secondary and tertiary packaging, and the nature of the device within the package.

5.1.3 The rate and volume exchange of air that the porous package encounters during its distribution and shelf life. This can be influenced by factors including the free-air volume within the package and pressure changes occurring as a result of transportation, manipulation, weather, or mechanical influences (such as room door closures and HVAC systems).

5.1.4 The microstructure of a porous material which influences the relative ability to adsorb or entrap microorganisms, or both, under different air-flow conditions.

6. Apparatus

6.1 This procedure should be conducted in a microbiological laboratory by trained personnel. As a result, it is assumed that basic microbiological equipment and supplies for conducting routine microbiological manipulations (that is, standard plate counts, sterilization with an autoclave, and so forth) will be available.

6.2 *Exposure Chamber*, constructed primarily from acrylic sheeting and consists of two major sections, as illustrated in Fig. 1. The bottom section contains a six-place manifold

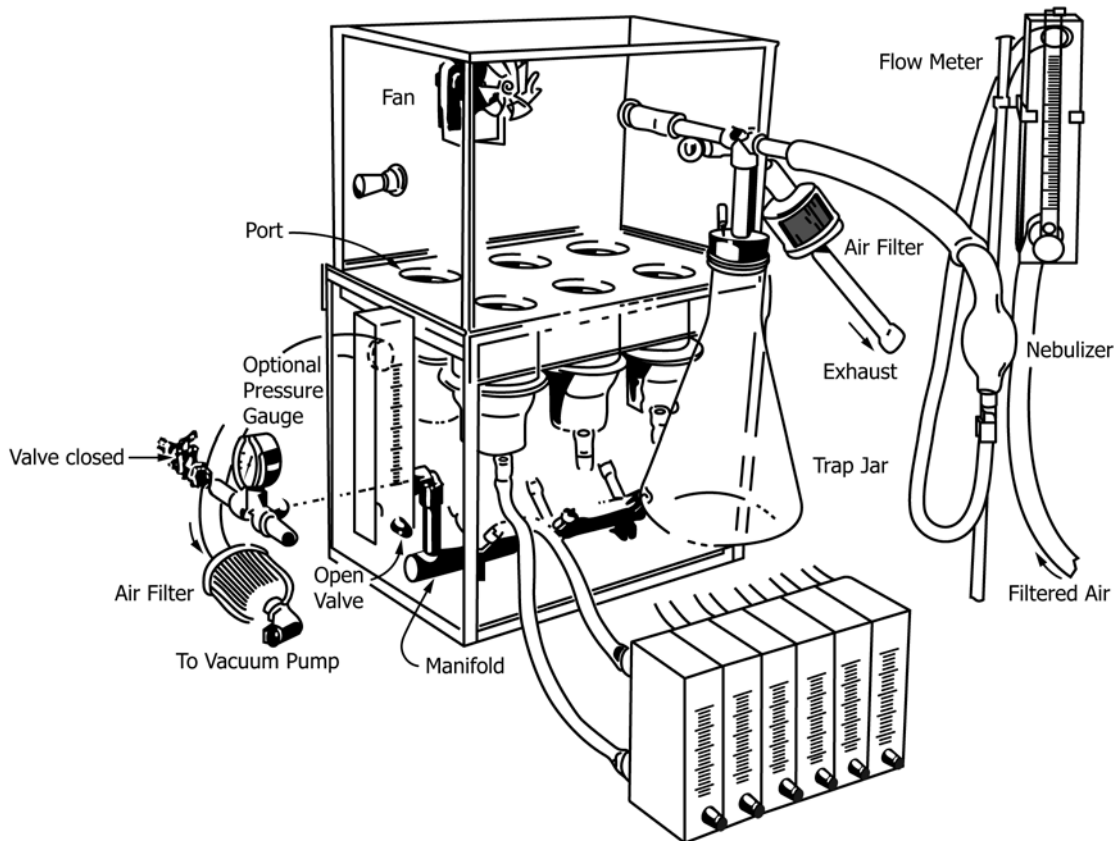

FIG. 1 Example of an Exposure Chamber

connected to six flowmeters, one per port, containing hoses attached to six filtering units. The port to the manifold is attached to a vacuum source. A vacuum gauge is mounted between the manifold and the vacuum source. The upper chamber contains a fan for dispersion of the bacterial aerosol, a port for attachment of the nebulizer, a port for exhausting the chamber, and a plate for attachment of disposable or sterilizable filter units. The chamber may use disposable filter units or reusable filter units, or both.

7. Materials

7.1 *Bacillus atropheus* (ATCC9372), aqueous spore suspension in water.

7.2 *Soybean Casein Digest Agar/Tryptic Soy Agar*—Bottles for pour plates and pre-poured plates (~25 mL in 100 by 15-mm plates) prepared commercially or in accordance with standard techniques.

7.3 *Sterile Cellulose Nitrate Filters*, 47 or 50-mm diameter, depending upon filter unit specification, 0.45- μ m pore size.

7.4 *Sterile Bottle-Top Filter Units*, (Falcon-type 7104 or filter holders with funnel 310-4000 or equivalent).

7.5 *Glass Nebulizer*.

7.6 *Sterile Forceps*.

7.7 *Incubator*, 30 to 35°C.

7.8 *Disk Cutter*, 47 or 50-mm diameter, depending upon filter unit specification.

7.9 *Sterile Gloves*.

7.10 *Sterile Syringe*, 3-cm³ with needle or micropipette.

7.11 *Sterile Pipettes*, to deliver 0.1, 1, 10, and 25 mL.

7.12 *Blender*, with sterile ½-pt jar(s).

7.13 *Vortex Mixer*.

7.14 *Vacuum Pump*, with air filter.

7.15 *NIST Traceable Calibrated Timer*.

7.16 *NIST Traceable Calibrated Flowmeters*—One pressure flowmeter with a range from 5 to 30 L/min; six vacuum flowmeters each with a range from 1.0 to 5.0 L/min.

7.17 *Sterile Petri Plates*.

7.18 *Sterile Water*, 100 and 9.9-mL aliquots, or other appropriate volumes for membrane grinding and dilutions.

7.19 *Hoses and Piping*— See Section 9 for lengths and diameters.

7.20 *Rubber Stoppers with Holes*—See Section 9 for sizes.

7.21 *Trap Jar*.

7.22 *NIST Traceable Calibrated Vacuum Gauge*.

7.23 *Compressed Air Source*, with air filter.

7.24 *Biocontainment Hood*.

7.25 *Chlorine Bleach*, or suitable sporicide.

8. Sample Preparation

8.1 Cut random samples of material into disks in accordance with the size required for the filter holder being used (47 or 50 mm) using a disk cutter. It is suggested that additional samples be cut to allow for errors during the procedure. Typically, the sample disks are sterilized prior to testing using a test method appropriate for the specific material. Materials may also be tested before or after they are subjected to other conditions such as heat or cold, relative humidity, different sterilization processes, real time, or accelerated aging. The samples may be stored in sterile petri plates or other suitable sterile containers before testing.

8.2 The minimum sample size for a given material is two, which was used in the round-robin study of this test method. However, it is strongly suggested that more samples be used to improve precision and bias (Section 14).

9. Apparatus Preparation

9.1 Since aerosols containing bacterial spores are formed during the use of this apparatus, the exposure chamber (see Fig. 1) should be assembled and used within a biological safety cabinet.

9.1.1 Place the top of the chamber on the bottom base.

9.1.2 Connect the top of each of the six flowmeters to the manifold using 0.65-cm inside diameter hoses. Connect the manifold to a filtered vacuum source.

9.1.3 Connect the bottom of each sample flowmeter to a filter unit with 0.65-cm inside diameter hose using an end connector.

9.1.4 Using a rubber hose, attach the nebulizer to a tee connector made of 0.65-cm PVC and three pieces of 0.6-cm inside diameter PVC piping approximately 7.5 cm long.

9.1.5 Attach the vertical leg of the tee to a trap jar using a rubber stopper with a 0.65-cm diameter hole. The trap jar is intended to retain any unsuspended droplets produced by the nebulizer.

9.1.6 Attach the second end of the tee to a 1.3-cm inside diameter rubber tubing approximately 3.8 cm long and connect to the front port of the chamber.

9.1.7 Attach a 1.3-cm inside diameter rubber tubing approximately 16 cm long to the mouth of the nebulizer. Connect the loose end of the tubing to the third end of the tee.

9.1.8 Connect the nebulizer inlet port with a 0.5-cm inside diameter rubber tubing to the top port of a calibrated flowmeter (from 5 to 30-L/min range).

9.1.9 Connect the bottom port of the flowmeter to a filtered air source.

9.1.10 Attach the exhaust port of the chamber that is used for evacuation to a 1.3-cm inside diameter tubing which, in turn, leads to an air filter and to a vacuum source.

9.2 *Filter Unit-Holder Preparation:*

9.2.1 Wrap the non-sterile sterilizable filter unit in a sterilizable wrap.

9.2.2 Sterilize the filter units as specified by the manufacturer. Presterilized filter units do not need to be resterilized.

10. Apparatus Validation

10.1 The test apparatus (see Fig. 1) must be validated for bacterial challenge to each port. This step should be performed upon first use of the chamber and a minimum of three runs should be conducted. The following description outlines the validation of the test procedure for a challenge of 1×10^6 colony forming units (CFU) per port in 15 min at a flow rate of 2.8 L/min. If testing is to be conducted using other parameters, a validation should be conducted using those parameters.

10.1.1 Place the sterile filtering apparatus in a biological safety cabinet.

10.1.2 Aseptically prepare six filter units by placing a sterile 0.45- μm membrane filter on the base of each filter unit using sterile forceps and gloves (Fig. 2B).

10.1.3 Attach the top of each filter unit to the bottom of the exposure chamber. Then attach each filter unit to its respective flowmeter.

10.1.4 Dispense 3.0 mL of the spore suspension into the nebulizer. When using the DeVilbiss #40 nebulizer, a volume of 3.0 mL at a concentration of 5×10^7 spores/mL is necessary to achieve a challenge of 1×10^6 CFU (± 0.5 log) per port in 15 min.

10.1.5 Turn on the chamber fan.

10.1.6 Adjust port flowmeters to 2.8 L/min. It is important that all ports be set to the same flow and monitored during the exposure period. Before adjusting each flowmeter, open each

valve completely, then slowly open the vacuum and fine adjust until the desired flow is achieved.

10.1.7 Adjust the nebulizer flow rate as recommended by the nebulizer manufacturer to produce droplets that are within the appropriate particle size range. When using the DeVilbiss #40 nebulizer, a flow rate of 8.5 L/min is used.

10.1.8 Immediately start the 15-min timer. At regular intervals, observe and adjust (if necessary) all flowmeters to maintain the appropriate flow rate settings during the 15-min test period.

10.1.9 After exposure, turn off the vacuum, the fan, and the air flow to the nebulizer. Open the filtered exhaust port at the back of the chamber.

10.1.10 Evacuate the chamber for 15 min by connecting the vacuum source to the front of the chamber through a microbial filter assembly.

10.1.11 Disconnect the hoses from each of the filter units and remove the units from the bottom plate of the exposure chamber.

10.1.12 Disinfect the outside of each filtering unit with a suitable sporicide being careful not to compromise the test material.

10.1.13 Remove the filter membranes aseptically, one at a time, and enumerate the organisms on each membrane (Fig. 3). Since more than 100 CFU are anticipated, the spores must be eluted from the membrane by grinding the membrane for 1 min in a suitable blender that has been validated containing 100.0 mL of sterile water. Samples are then serially diluted prior to performing standard plate counts to accurately determine the number of spores. A dilution and plating scheme, which was

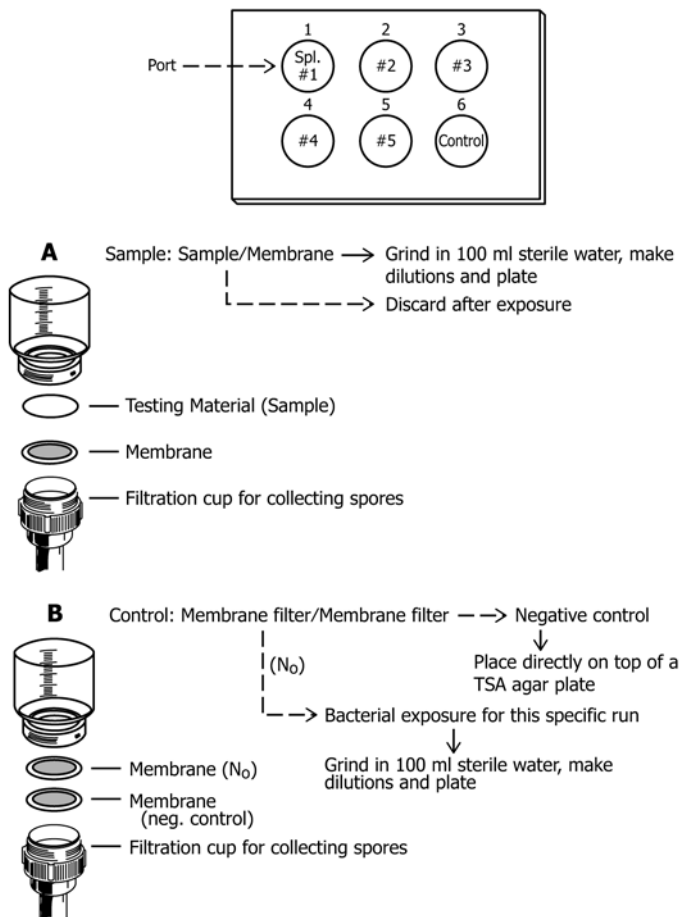

FIG. 2 Sample and Control Material Setup

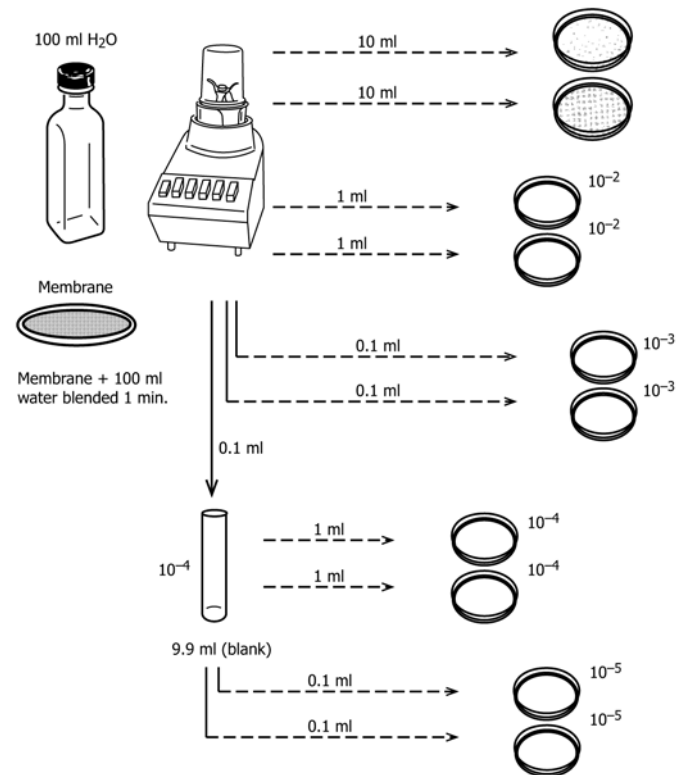

FIG. 3 Example of Possible Dilution Scheme

used in the round-robin study, includes plating 10.0, 1.0, and 0.1-mL aliquots of the blended membrane in duplicate. An additional 1 to 100 dilution is prepared by placing 0.1 mL in 9.9 mL of sterile water and plating 1.0 and 0.1-mL aliquots of this dilution in duplicate. This scheme produces dilution factors of 10^{-1} , 10^{-2} , 10^{-3} , 10^{-4} , and 10^{-5} . Other validated extraction and enumeration protocols may be used. Plates having between 25 and 250 CFU should be used for enumeration. If alternative test conditions are used, then the previously described dilution scheme may not be appropriate. In instances where colony counts are less than 30 CFU, the limit of detection is dependent upon the volume of the undiluted aliquot plated from the blender jar. Duplicate 10-mL samples will result in a limit of detection of 5 CFU/membrane. If a lower limit is desired, plate an appropriately larger volume. However, there is increased statistical variation with these low numbers. If the membrane grinding and plating procedure consistently results in counts less than 25 CFU from all dilutions, enumeration can be accomplished by placing the membrane directly onto the surface of a SCDA plate with the challenge side up.

10.1.14 Enumeration cultures are incubated for a minimum of 24 h at 30 to 35°C. If incubated longer than 24 h, care should be taken to ensure that individual colonies remain discrete and overgrowth does not occur and that the growth media does not dry out.

10.1.15 After incubation, count and record the number of CFUs and dilution factor for each filter.

10.1.16 A minimum distribution of 1×10^6 (± 0.5 log) spores is recommended. To increase the challenge per port, increase the concentration of the aqueous spore suspension rather than the volume.

10.1.17 All ports must receive the same bacterial challenge (± 0.5 log) for successful validation.

10.2 *Revalidation and Validation of Alternative Test Parameters*—After validation has been performed using the standard test parameters as described in 10.1 – 10.2, an appropriate number of validation runs should be performed when changes are made which have potential effects on bacterial distribution. Environmental conditions, equipment modifications, and changes in test parameters may be necessary considerations. If it is desired to perform testing using different test parameters, the test apparatus should be revalidated using those conditions.

11. Microbial Procedures for Testing Samples

11.1 Place the sterile filtering apparatus in a biological safety cabinet.

11.2 Aseptically place a sterile 0.45- μ m membrane filter on the base of each unit, using sterile forceps and gloves (Fig. 2A).

11.3 Place an appropriate diameter disk of test material on top of the membrane (Fig. 2A).

11.3.1 If the materials to be tested are known to produce high LRV values, it may be advisable to include a sample of a known material which allows substantial passage of spores in

each run. A known material will also provide a frame of reference. In this case, refer to the sample as the positive control.

11.4 Prepare one of the six units with the challenge control membrane (N_0) on top of the sterile 0.45- μ m membrane filter (Fig. 2B).

11.4.1 This bottom 0.45- μ m membrane filter serves as the negative control.

11.5 Attach the top of each filter unit to the bottom of the exposure chamber. Then attach each filter unit to its respective flow meter.

11.6 Dispense 3.0 mL of spore suspension into the nebulizer. Use the concentration of spore suspension required to achieve the desired challenge level as determined during the apparatus validation. The suspension should be thoroughly mixed prior to use.

11.7 Turn on the chamber fan.

11.8 Adjust port flowmeters to 2.8 L/min. It is important that all ports be set to the same flow and monitored during the exposure period. Before adjusting each flowmeter, open each valve completely, then slowly open the vacuum and fine adjust until the desired flow is achieved.

NOTE 1—For comparing different materials, the standard test parameters are a flow rate of 2.8 L/min to provide a minimum challenge of 1.0×10^6 CFU ± 0.5 log per sample within 15 min. The comparison achieved with these parameters does not necessarily correlate with or predict performance of the material when different parameters are used.

11.9 Adjust the nebulizer flowmeter to a flow rate that will produce droplets that are within the appropriate particle size range.

11.10 If necessary, adjust the system vacuum to achieve the desired flow rate.

NOTE 2—When testing samples of materials, take care to apply enough vacuum to achieve the desired flow rate, but not enough to cause damage to the 0.45- μ m membrane filter or the test material. If the porosity of a material sample is too low to apply the stated flow rate without damaging the membrane or material, a lower flow rate should be used and documented. If a sufficient flow cannot be attained, this test method should not be used. Generally, an applied vacuum of less than 12 in. Hg will not result in damage to the membrane or materials.

11.11 Immediately start the 15-min timer. At regular intervals, observe and adjust (if necessary) all flowmeters to maintain the appropriate flow rate settings during the 15-min test period or other validated time interval. Document any adjustments.

11.12 After exposure, turn off the vacuum, and the fan and the airflow to the nebulizer; Open the filtered exhaust port at the back of the chamber.

11.13 Evacuate the chamber for 15 min by connecting the vacuum source to the chamber through a microbial filter assembly.

11.14 Disconnect the hoses from the filter units and remove the units from the bottom plate of the exposure chamber.

11.15 Disinfect the outside of each filtering unit with a suitable sporicide being careful not to compromise the test material.

11.16 Using sterile forceps, remove the testing material. Discard or hold for further testing if desired.

11.17 Remove the filter membranes aseptically, one at a time, and enumerate the organisms on each membrane (see 10.1.13). If all dilutions consistently result in less than 25 CFU/plate, enumeration can be accomplished by placing the membrane directly onto the surface of a SCDA plate with the challenge side up. Direct plating of the membrane filter should be done with caution. This test method of enumeration improves the limit of detection, but could obscure the actual number of spores that passed through the material if all the spores were deposited in a very small area resulting in a single colony. Additional methods of extraction and enumeration are acceptable provided they have been validated before use.

11.18 Aseptically remove and enumerate the challenge control (N_0) membrane. Serially dilute and perform standard plating procedures to accurately determine the number of spores. Remove the negative control membrane and place it directly on an agar plate.

11.19 Incubate the SCDA plates for a minimum of 24 h at 30 to 35°C. If incubated longer than 24 h, take care to ensure that individual colonies remain discrete and overgrowth does not occur and that the growth media does not dry out.

11.20 After incubation, count and record the number of colony-forming units per membrane and the dilution factor. If direct plating of the membrane is conducted and the CFU/filter exceeds 100, it may be necessary to rerun the test and assay the membrane filters using other extraction methods.

12. Calculation of Log Reduction Value

12.1 The ability of a packaging material to resist passage of microorganisms is expressed as the log-reduction value (LRV) which is calculated by the following equation:

$$LRV = \log_{10} N_0 - \log_{10} N_1 \quad (1)$$

where:

N_0 = average bacterial challenge determined from the challenge control filter, CFU,

N_1 = average number of bacteria passing through Test Sample 1, CFU. If $N_1 < 1$, then use $N_1 = 1$.

NOTE 3—It is not appropriate to calculate an LRV with values less than 1. Using these types of values will artificially increase the LRV resulting in calculated titers above what was challenged. If looking to estimate calculations use 1 for values less than 1.

12.2 If the bacterial challenge in any run varies more than ± 0.5 log from the targeted average, that run should be considered invalid and repeated.

12.3 If a large number of colonies appear on the negative control from a given run, it may be appropriate not to use data from that run. This judgment should be made with regard to the limit of detection (LOD) for a test sample. If 1 CFU appears on the negative control and the limit of detection for a test sample is 5 CFU, the data from that run should be included. However, if 100 CFU appear on the negative control, and the test material averages 10 CFU, the validity of the data is questionable. The LOD is the volume used for the extraction divided by the volume tested.

12.4 Table 1 is an example of a LRV calculation. Although not necessarily included in a routine run, calculations for both positive and negative controls have been included in the example. Use of the negative control has been previously discussed. Positive controls (materials which pass a given level of spores) may also be used to confirm the consistency of the operator or chamber, or both. In this example there are three runs with a total of 12 samples (N_1) replicates, three N_0 control filters, three negative control filters and three positive control material samples.

12.5 The average bacterial challenge (N_0) is determined from the N_0 control filter and is calculated to be 9.1×10^5 CFU. In all three runs, the challenge control was within ± 0.5 log of 1.0×10^6 CFU.

12.6 The average number of bacteria passing through the test material (N_1) is determined from the filter beneath each of the samples and is calculated to be 48.5 CFU.

12.7 Substituting these values into Eq 2:

$$\begin{aligned} LRV &= \log_{10} (9.1 \times 10^5) - \log_{10} (48.5) \quad (2) \\ &= 5.959 - 1.686 \\ &= 4.27 \end{aligned}$$

12.8 The relationship between log-reduction value and the percentage of spores retained by the test material is as follows:

| Log-Reduction Value | Spores Retained, % |
|---------------------|--------------------|
| 1.0 | 90 |
| 2.0 | 99 |
| 3.0 | 99.9 |
| 4.0 | 99.99 |
| 5.0 | 99.999 |

TABLE 1 Example of LRV Calculation

| Run No. | Test Samples, CFU ^A | | | | Controls, CFU | | |
|---------|--------------------------------|-------|------|------|---|--------------|--|
| | A | B | C | D | N_0 ($\times 10^4$) ^A | Negative | Positive ($\times 10^2$) ^A |
| 1 | 37.5 | 47.0 | 41.0 | 53.5 | 84.2 | 0 | 31.5 |
| 2 | 57.0 | 55.5 | 43.0 | 62.5 | 102.8 | 0 | 46.0 |
| 3 | 33.0 | 50.5 | 53.0 | 48.5 | 86.0 | 0 | 53.0 |
| Average | | 48.5 | | | 9.1×10^5 | 0 | 4.4×10^3 |
| Log | | 1.686 | | | 5.959 | ^B | 3.643 |
| LRV | | 4.27 | | | ^B | ^B | 2.32 |

^A Mean of duplicate plate counts.

^B Not applicable.

13. Report

13.1 Report the information contained on the attached worksheet and show the calculation of the LRV for each test material. Fig. 4 is only intended to be an example. Each user may customize the worksheet to meet his own needs, as long as the pertinent information is included.

14. Precision and Bias

14.1 Statements on precision and bias for sample sizes of 2, 5, and 10 specimens are in 14.4 to 14.7.

14.2 *Interlaboratory Test Data*—An interlaboratory test was run in 1993 in which two randomly cut samples from each of six materials and one positive control were tested by one operator in each of eleven laboratories. The testing was performed using the standard conditions described in this test method. The positive control was the same material as one of the test samples (45B). The microbial-barrier effectiveness was measured in terms of LRV. Pooled estimates of within-laboratory and laboratory-to-laboratory variation across all materials were used for single-operator and multilaboratory

**Standard Test Method for Microbial Ranking of Porous Packaging Materials
(Exposure Chamber Method)
DATA WORKSHEET**

Performing Laboratory: _____ **Operator:** _____

Date: _____ **Run Number:** _____

Sample ID/Description: _____

Inoculum Concentration: _____ **Inoculum Volume:** _____

Nebulizer Air Pressure: _____ **Vacuum Level:** _____

Exposure Time: _____ **Sample Flow Rate:** _____

| <u>SAMPLE ID</u> | <u>Filter Location</u> | <u>Plate Counts (CFU)</u> | | <u>Dilution Factor</u> | <u>Total CFU</u> |
|------------------------|------------------------|---------------------------|---------------|------------------------|------------------|
| | | <u>Rep. 1</u> | <u>Rep. 2</u> | | |
| Challenge Control (No) | | | | | |
| Negative Control | Same As Above | | N/A | N/A | |
| | | | | | |
| | | | | | |
| | | | | | |
| | | | | | |
| | | | | | |

Comments: _____

FIG. 4 Data Worksheet

precision to obtain enough degrees of freedom for the estimates. The design of the round-robin study was similar to that of Practice E691.

14.3 *Test Result*—The precision information given in Table 2 for average LRV is for the comparison of two test results, each of which is an average of n specimens.

14.4 *Precision in Terms of the Coefficient of Variation or Relative Error*—See Table 3, Table 4, and Table 5. Test results that differ by the critical difference or more are statistically different at the 95 % level of confidence.

14.5 *Precision in Terms of Absolute Values*—See Table 6, Table 7, and Table 8.

14.6 *Bias*—This test method has no known bias. No justifiable statement can be made on the bias of this test method for assessment of the LRV since the true values are unknown.

14.7 The critical differences given in this test method should be considered to be a general statement of precision, particularly with respect to reproducibility or between-laboratory precision. The amount of statistical bias between any two laboratories must be based on recent data obtained on samples randomly taken from one material before a meaningful statement can be made.

TABLE 2 Microbial Barrier Performance of Various Materials—Precision Statistics Calculated Using Practice E691^{A,B}

| Material | x | S_r | S_R | r | R |
|--------------------------|--------|--------|--------|------|------|
| A1, positive control | 1.7151 | 0.2592 | 0.3441 | 0.73 | 0.96 |
| A2, (45B) | 1.7326 | 0.2571 | 0.3566 | 0.72 | 1.00 |
| A3, (A1 and A2 combined) | 1.7221 | 0.2507 | 0.3478 | 0.70 | 0.97 |
| F (36.5) | 2.1008 | 0.2251 | 0.3286 | 0.63 | ... |
| B (53) | 2.5619 | 0.3061 | 0.3976 | 0.86 | 1.11 |
| C (50) | 3.2820 | 0.3130 | 0.6075 | 0.88 | 1.89 |
| D (CT) | 4.3416 | 0.2744 | 0.9812 | 0.77 | 2.75 |
| E (45MF) | 3.3686 | 0.5513 | 0.6454 | 1.54 | 1.81 |
| G (0.45- μ filter) | 5.9620 | 0.2077 | 0.2753 | 0.58 | 0.77 |

^AThe abbreviations used in Table 1 are defined in Practice E691 where:
 x = average of cell averages (average of the LRV averages for each material from each laboratory),

S_r = repeatability standard deviation for each material,

S_R = reproducibility standard deviation for each material,

r = 95 % repeatability limit for each material, and

R = 95 % reproducibility limit for each material.

^BThe information presented in Table 1 was calculated from the LRV of the test materials. In the round-robin study, the positive control material was the same as Test Material 45B. Therefore, statistical analyses were calculated treating the two materials as distinct entities (A1 and A2) and then on pooled LRV data (A3). For Material G, the 0.45- μ m filter used to determine the microbial challenge, the data in Table 1 was calculated from the \log_{10} of the number of CFU on the membrane filter.

TABLE 3 95 % Repeatability Limit (or Single-Operator Within-Laboratory Critical Difference)

| n | Critical Difference, % | Standard Deviation |
|-----|------------------------|--|
| 2 | 16.0 | 5.7 % of the average of the test results |
| 5 | 10.1 | 3.6 % |
| 10 | 7.0 | 2.5 % |

TABLE 4 95 % Reproducibility Single-Material Limit (or Between-Laboratories Single-Material Critical Difference)

| n | Critical Difference, % | Standard Deviation |
|-----|------------------------|---|
| 2 | 39.8 | 14.2 % of the average of the test results |
| 5 | 37.5 | |
| 10 | 37.0 | 13.2 % |

TABLE 5 95 % Reproducibility Multi-Materials Limit (or Between-Laboratories Multi-Materials Critical Difference)

| n | Critical Difference, % | Standard Deviation |
|-----|------------------------|---|
| 2 | 52.4 | 18.7 % of the average of the test results |
| 5 | 50.7 | 18.1 % |
| 10 | 50.4 | 18.0 % |

TABLE 6 95 % Repeatability Limit (or Single-Operator Within-Laboratory Critical Difference Between Two Test Results)

| n | Critical Difference, LRV | Standard Deviation, LRV Units |
|-----|--------------------------|-------------------------------|
| 2 | 0.44 ^A | 0.156 |
| 5 | 0.28 | 0.098 |
| 10 | 0.19 | 0.070 |

^A For example, two test results that differ by 0.44 LRV or more, are statistically different at the 95 % level of confidence for test results that are averages of two specimens each.

TABLE 7 95 % Reproducibility Single-Material Limit (or Between-Laboratory Single-Material Critical Difference Between Two Test Results)

| n | Critical Difference, LRV | Standard Deviation, LRV Units |
|-----|--------------------------|-------------------------------|
| 2 | 1.09 | 0.386 |
| 5 | 1.03 | 0.367 |
| 10 | 1.01 | 0.360 |

15. Keywords

15.1 biological barrier; medical packaging; microbial barrier; microbial-challenge; porous packaging; sterile barrier; sterile packaging

TABLE 8 95 % Reproducibility Multi-Material Limit (or Between-Laboratory Multi-Material Critical Difference Between Two Test Results)

| n | Critical Difference, LRV | Standard Deviation, LRV Units |
|----|--------------------------|-------------------------------|
| 2 | 1.44 | 0.510 |
| 5 | 1.39 | 0.495 |
| 10 | 1.37 | 0.491 |

BIBLIOGRAPHY

- (1) Placencia, A. M., Oxborrow, G. S., and Peeler, J. T., *Package Integrity Methodology for Testing the Biobarrier Properties of Porous Packaging, Part I: Membrane Agar Plate Strike-Through Method*, Medical Device and Diagnostic Industry, April 1986.
- (2) Placencia, A. M., Oxborrow, G. S., and Peeler, J. T., *Package Integrity Methodology for Testing the Biobarrier Properties of Porous Packaging, Part II: FDA Exposure Chamber Method*, Medical Device and Diagnostic Industry, May 1986.
- (3) Placencia, A. M., Arin, M. L., Peeler, J. T., and Oxborrow, G. S., *Physical Tests are Not Enough*, Medical Device and Diagnostic Industry, September 1988 .
- (4) Placencia, A. M., and Peeler, J. T., "Package Integrity of Medical Devices Using Microbial Test Methods and Comparative Studies Using Physical Methods," *Proceedings of the IAPRI Congress, World Conference on Packaging '89, Hamburg, Sept. 27–29, 1989, Section 15.2*, pp. 531–540.
- (5) *Bergey's Manual of Systematic Bacteriology*, Williams & Wilkins, Baltimore, MD 21202, Vol 2, p. 1130.
- (6) *Standard Methods for the Examination of Water and Wastewater*, APHA, AWWA WPCF, American Public Health Association, Washington, DC, 20005, 16th ed., 1985, pp. 866–869.

ASTM International takes no position respecting the validity of any patent rights asserted in connection with any item mentioned in this standard. Users of this standard are expressly advised that determination of the validity of any such patent rights, and the risk of infringement of such rights, are entirely their own responsibility.

This standard is subject to revision at any time by the responsible technical committee and must be reviewed every five years and if not revised, either reapproved or withdrawn. Your comments are invited either for revision of this standard or for additional standards and should be addressed to ASTM International Headquarters. Your comments will receive careful consideration at a meeting of the responsible technical committee, which you may attend. If you feel that your comments have not received a fair hearing you should make your views known to the ASTM Committee on Standards, at the address shown below.

This standard is copyrighted by ASTM International, 100 Barr Harbor Drive, PO Box C700, West Conshohocken, PA 19428-2959, United States. Individual reprints (single or multiple copies) of this standard may be obtained by contacting ASTM at the above address or at 610-832-9585 (phone), 610-832-9555 (fax), or service@astm.org (e-mail); or through the ASTM website (www.astm.org). Permission rights to photocopy the standard may also be secured from the Copyright Clearance Center, 222 Rosewood Drive, Danvers, MA 01923, Tel: (978) 646-2600; <http://www.copyright.com/>