



Standard Practice for Evaluation of Metallic Weapons Detectors for Controlled Access Search and Screening¹

This standard is issued under the fixed designation F1468; the number immediately following the designation indicates the year of original adoption or, in the case of revision, the year of last revision. A number in parentheses indicates the year of last reapproval. A superscript epsilon (ϵ) indicates an editorial change since the last revision or reapproval.

1. Scope

1.1 This practice covers methods for the evaluation of walk-through metal weapons detectors and criteria for testing metal detection performance.

1.2 This practice specifies certain health, safety, and human factors criteria pertaining to the usage of the detection equipment.

1.3 This practice requires the use of non-standardized (user-supplied) test objects and test equipment. Evaluations made using the procedures outlined in this practice can be used for comparative evaluations only if the tests are made with the same equipment and test objects.

1.4 This practice is intended for use by manufacturers and evaluators of electromagnetic field devices used for screening persons entering into controlled access areas. It is not intended to set performance nor limit or constrain operating technologies, nor is it a document for use by individual operators or users of such equipment at specific access control points.

1.5 The values stated in SI units are to be regarded as the standard. Other units given in parentheses are for information only.

1.6 *This standard does not purport to address all of the safety concerns, if any, associated with its use. It is the responsibility of the user of this standard to establish appropriate safety and health practices and determine the applicability of regulatory limitations prior to use.* For a specific hazards statement, see warning note in [12.2.5](#).

2. Referenced Documents

2.1 ANSI/IEEE Standard:

[C62.41 IEEE Guide for Surge Voltages in Low Voltage AC Power Circuits](#)²

¹ This practice is under the jurisdiction of ASTM Committee F12 on Security Systems and Equipment and is the direct responsibility of Subcommittee F12.60 on Controlled Access Security, Search, and Screening Equipment.

Current edition approved May 1, 2010. Published May 2010. Originally approved in 1993. Last previous edition approved in 2004 as F1468 – 04a. DOI: 10.1520/F1468-04AR10.

² Available from Institute of Electrical and Electronics Engineers, Inc. (IEEE), 445 Hoes Ln., P.O. Box 1331, Piscataway, NJ 08854-1331, <http://www.ieee.org>.

3. Terminology

3.1 Definitions of Terms Specific to This Standard:

3.1.1 *clean tester*—person who does not carry any objects which would significantly alter the signal produced when the person carries a test object; smaller test objects require more complete elimination of metallic objects. By example but not limitation, such significant objects may include: metallic belt buckles, metal buttons, cardiac pacemakers, coins, metal-frame eye glasses, hearing aids, jewelry, keys, mechanical pens and pencils, shoes with metal shanks or arch supports, metallic surgical implants, undergarment support metal, and metal zippers. A clean tester passing through a metal detector shall not cause a disturbance signal greater than 10 % of that produced when carrying the critical test object through the detector. The tester shall have a mass between 50 and 100 kg (110 and 220 lb) and a height between 1.50 and 1.90 m (59 and 75 in.). If the detector is designed to be sensitive to body size because of design or desired sensitivity, the physical size of testers should be smaller and within a narrower range.

3.1.2 *critical orientation*—orientation of a test object which produces the smallest detection signal or weakest detection.

3.1.3 *critical sensitivity setting*—sensitivity setting of a detector at which the critical test object in its critical orientation is detected at a 90 % or greater rate at the weakest or critical test point for the detector.

3.1.4 *critical test object*—test object out of a given group of objects which, in its worst-case or critical orientation, produces the worst-case or critical sensitivity setting for a specific detector. The group shall comprise one or more objects which are to be detected under the same detector settings.

3.1.5 *critical test point*—location within the passage opening of a detector portal which produces the weakest signal response (the critical sensitivity) for the critical test object at its critical orientation.

3.1.6 *detector*—synonym (used in this practice for brevity) for a walk-through device for detecting weapons such as defined in [3.1.14](#).

3.1.7 *discrimination ratio*—expression of a detector's ability to discriminate between a weapon and innocent personal possessions; it is the ratio of the signal generated by a critical

test object to the signal generated by an assortment of innocent personal possessions (see Section 8).

3.1.8 *electrical influence test probe*—air-core coil for creating electromagnetic fields that could influence detector capability (see 15.3).

3.1.9 *induced electromagnetic field test probe*—air-core coil for measuring the strength of the electromagnetic fields generated by a detector (see 15.2).

3.1.10 *outside influence*—site-related situation or occurrence of a mechanical or electrical nature which alters the normal operation of the detector.

3.1.11 *test object*—any metallic object used to evaluate the detection capability of a detector. See 7.2 for specific requirements.

3.1.12 *test probe*—testing devices as specified in 15.2 – 15.4, utilized in the simulation of outside influences.

3.1.13 *testing laboratory site*—area suitable for proper testing and evaluation of detectors (see Section 6).

3.1.14 *walk-through weapons detection device (detector)*—freestanding screening device, utilizing an electromagnetic field within its portal structure, for detecting metallic weapons concealed on persons walking through the structure.

3.1.15 *weapon*—device intended to do damage to personnel or equipment without intentionally harming the attacker, but requiring the attacker to physically activate the device. Examples include guns, knives, and hand grenades.

4. Significance and Use

4.1 The significant attributes of this practice are the methods for determining the detection capabilities of metal detectors, the methods for determining the effects of outside influences on detectors, and certain safety requirements for detectors.

4.2 While this practice was originated for walk-through metal weapons detectors, it is equally applicable to detectors of other metal objects. The innocent objects set (15.1.2) would require modification commensurate with the size of the other object to be tested; some tests may not be applicable and other specific and different tests may be necessary.

4.3 This practice includes testing site requirements (Section 6) to minimize data variations. These methods may be used at nonconforming sites if site-related disturbances are considered and accounted for.

4.4 This practice is not meant to constrain designs but it is applicable only to detectors which are designed for individual walk-through. The portal structure shall be deemed to meet this criterion if it provides a minimum vertical clearance of 1.96 m (77 in.) and a minimum horizontal width clearance of 0.66 m (26 in.).

4.5 This practice recognizes that the complex movements of a test object when carried by a person walking through a detector limits the precision and repeatability of the resultant observed signals. Averaged results from repeated tests under identical controlled conditions are recommended to obtain a better approximation of the underlying hypothetical true value for that set of conditions.

4.6 Where the term “significant” is used, it refers to phenomena which, in accordance with accepted engineering practices, exceed the normal variation of data.

5. Safety Requirements

5.1 *Personal Health and Safety*—The health and safety of searchees, operators, and other persons using or coming in contact with the equipment shall have been considered in the equipment design. In addition to the tip-over tests in 5.4 and 5.5, any hazards concerning factors in 5.2 and 5.3 shall be included in the evaluation report.

5.2 *Mechanical*—The equipment shall be free of sharp corners or protrusions that can puncture the skin or clothing or injure persons moving normally within the immediate area. Any potential tripping hazards, such as wires, cables, anti-tilt devices, ramps, etc. shall also be noted on the report.

5.3 *Electrical*—The detector shall be free of potential electrical shock hazards during operation.

5.4 *Portal Tip-Over*—With a stop at the base of the detector to prevent sliding, a force shall be applied at or near the top of the detector in the direction of search passage until the detector starts to tip. The tipping moment, calculated as the height above the floor times the maximum force required, shall be recorded in the evaluation report. If anti-tilt fixtures or accessories are provided or recommended by the detector manufacturer, tests shall be conducted with and without such devices and recorded in the report.

5.5 *Accessory Table or Pedestal Tip-Over*—Test as in 5.4 except apply the force at the point and in the direction for easiest tipping. Record the resultant moment.

5.6 Tip-over testing is not required if a detector must be anchored for proper operation.

6. Testing Laboratory Site and General Requirements

6.1 *Distancing Requirements*—Sites in which detectors are tested and evaluated shall be free of significant extraneous influences.

6.1.1 Walls, furniture, lighting, electrical power lines, etc. of metallic content or of electrically influencing nature (except for lines supplying power to the detector and interconnecting its components) shall be at least 3 m (10 ft) distant.

6.1.2 Overhead structures, such as ceilings or lights, shall be at least 1 m (40 in.) distant from the nearest surface of the detector and free of electrical lines within 3 m (10 ft).

6.2 *Floor Requirements*—The floor shall be solid and not capable of transferring vibration or shake to the detector of an amplitude discernible in the detector signal output when a clean tester walks through. It shall be free of steel except for nails or reinforcing bars. No electrical lines shall run in or under the floor closer than 2 m (6.5 ft) to any portion of the detector. If the manufacturer recommends shielding, such as an aluminum floor liner or elevated platform, it shall be in place before testing.

6.3 The working area shall include sufficient space for the detector and instrumentation equipment, and for personnel to operate it conveniently. The number of instrumentation stands

or carts shall be minimized. They shall have low metal content and be located so that they do not influence test results.

6.4 Determine by appropriate engineering techniques that the testing site is free and remains free of all electrical influences which might affect the tests. This includes verification of the quality of the detector power source. Record in the evaluation report any deviations from 6.1 – 6.4.

6.5 The detector shall be in a totally operational condition, complete with such items as floor or wall shieldings, electronics pedestals, etc., in their normal operational position.

6.6 Many of the following sections require quantitative measurements of signal magnitude. Manufacturers who do not provide quantitative measurements of signal magnitude shall specify alternative procedures which will provide equivalent evaluation capability.

7. Procedure for Testing Detection Performance

7.1 The purpose of this procedure is to establish the sensitivity setting which is required for the detection of the worst-case test object in its worst orientation at the least-sensitive location within the portal opening. This is the critical sensitivity for detection of the critical test object in its critical orientation at the critical test point.

7.2 For the evaluation of detectors under this practice, the test object or objects shall be actual (not simulated) objects which, individually or collectively, represent the characteristics of the weapons or other contraband objects which it is designed to detect.

7.3 As an otherwise clean tester walks through a detector carrying a test object, the path taken by the object can be approximated by a straight line through a horizontally and vertically located point within the portal opening. This ignores the side-to-side rocking, vertical bouncing, body rotation, and velocity surging which the walking motion exhibits. These secondary motions alter the signal generated by a test object when it is carried by an otherwise clean tester, compared to the signal from the same test object when carried by a hypothetical mechanized straight-line carrier apparatus.

7.3.1 To better simulate expected actual usage, a walk-through of a clean tester carrying a test object must be repeated sufficient times for statistical accuracy to produce the definitive critical sensitivity data.

7.4 A mechanized carrier produces more consistent data. When such equipment is available, its use is recommended for determining the intrinsic sensitivity topography of a detector. Normally, the critical test object, its critical orientation, and the critical grid location point can be determined, along with an approximate critical sensitivity.

7.4.1 A walk-through is necessary to determine the actual critical sensitivity. In the absence of a conflicting requirement, walk-throughs shall be at an approximate velocity of 1 m/s (3 ft/s).

7.5 If a mechanized carrier is not available, the same tests can be performed by a person carrying the test object. Several identical passes are necessary to obtain adequate consistency.

7.6 Test Object Orientation:

7.6.1 The nomenclature and positions given in Fig. 1 refer to the orientation of weapons (guns or other weapons) with respect to the metal detectors.

7.7 The comprehensive test for determining detector sensitivity requires passing all test objects in a group in all orientations through all points of a selected grid pattern within the portal opening. This must be repeated for all combinations of optional operating modes, multiple channels, and alternate configurations. The amount of testing required may be reduced by the following procedures.

7.7.1 In the absence of other criteria, start sensitivity measurements at a grid location point at the horizontal center between the side panels and vertically equidistant from both top and bottom ends of all panel coils; a vertical height from the floor of 0.8 to 1.0 m (30 to 40 in.) is usable.

7.7.2 Begin with the vertical object orientation 3 as indicated in Fig. 1. Pass all objects in the test object group to be evaluated through the detector. Remove test objects which produce a signal twice as large as the smallest signal for the group.

7.7.3 Test the remaining objects in the other two mutually orthogonal orientations (across and in-out). Remove objects in orientations that produce signals 50 % larger than the smallest signal.

7.7.4 Using only the objects and orientations not eliminated in 7.7.2 and 7.7.3, determine the signals produced at intervals along a vertical axis centered between the panels. If the signals are relatively constant, grid intervals of 0.2 m (8 in.) are adequate. Near the top and bottom and near any area producing abrupt changes in sensitivity, intervals of 0.1 m or 0.05 m may be necessary. The critical object and orientation will usually be the combination giving the weakest response.

7.7.4.1 The critical test object can vary as a result of program selection. Repeat 7.7.2 – 7.7.4 for all program versions to be evaluated.

7.7.5 Determine the signals at intervals across the portal opening for the critical object and orientation of 7.7.4. This shall be at a vertical height in accordance with 7.7.1, which according to 7.7.4, indicates does not have an abrupt change in sensitivity. Intervals of 100 mm (4 in.) are normally adequate unless an abrupt change is discerned. If this does occur, repeat tests across the opening at other vertical positions to locate and pinpoint the area of the critical test point.

7.7.6 For any given usage of a metal detector, it is the responsibility of the evaluator to decide on the exact area within the portal opening from which the critical detection point will be determined.

7.7.7 From the data obtained in 7.7, select the critical test object, orientation, location, and sensitivity setting within the area of interest in accordance with 7.7.6. Record this data for each program setting in the evaluation report.

7.7.8 For the critical sensitivity setting of 7.7.7 and with no test object, determine and record the ambient or background signal level.

7.7.9 For the critical sensitivity setting of 7.7.7 and with no test object, determine and record the signal level when the clean tester walks through.











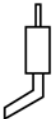



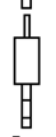

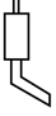
1		<i>BARREL UP BUTT LEFT</i>		<i>BLADE UP EDGE LEFT</i>
2		<i>BARREL UP BUTT AWAY</i>		<i>BLADE UP EDGE AWAY</i>
3		<i>BARREL UP BUTT TOWARDS</i>		<i>BLADE UP EDGE TOWARDS</i>
4		<i>BARREL UP BUTT RIGHT</i>		<i>BLADE UP EDGE RIGHT</i>
5		<i>BARREL LEFT BUTT DOWN</i>		<i>BLADE LEFT EDGE DOWN</i>
6		<i>BARREL LEFT BUTT TOWARDS</i>		<i>BLADE LEFT EDGE TOWARDS</i>
7		<i>BARREL LEFT BUTT AWAY</i>		<i>BLADE LEFT EDGE AWAY</i>
8		<i>BARREL LEFT BUTT UP</i>		<i>BLADE LEFT EDGE UP</i>
9		<i>BARREL RIGHT BUTT DOWN</i>		<i>BLADE RIGHT EDGE DOWN</i>
10		<i>BARREL RIGHT BUTT AWAY</i>		<i>BLADE RIGHT EDGE AWAY</i>
11		<i>BARREL RIGHT BUTT TOWARDS</i>		<i>BLADE RIGHT EDGE TOWARDS</i>
12		<i>BARREL RIGHT BUTT UP</i>		<i>BLADE RIGHT EDGE UP</i>

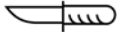
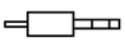
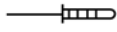
FIG. 1 Test Object Orientation

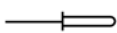
7.7.10 For the critical conditions of 7.7.7, determine and record the effect, if any, when the walking velocity of the tester is reduced from the normal 1 to 0.5 m/s (3.0 to 1.5 ft/s) and also when it is increased to 1.3 m/s (4.2 ft/s).

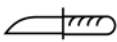
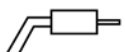
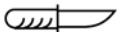
8. Procedure for Measuring Metallic Discrimination

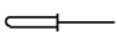
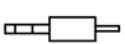
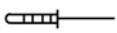
8.1 The primary purpose of this procedure is to determine a detector's ability to discriminate between innocent personal possessions and the objects to be detected.

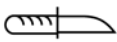
8.2 With the detector operating under the same conditions and sensitivity as used for 7.7.7, determine the signal generated by a clean tester carrying the critical test object at its critical orientation and location.

8.3 With the detector operating under the same conditions and sensitivity as used for 7.7.7, determine the signal generated by a clean tester carrying only the array of personal possession objects at their given locations in accordance with 15.1











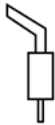

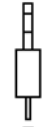











13		<i>BARREL DOWN BUTTLEFT</i>		<i>BLADE DOWN EDGE LEFT</i>
14		<i>BARREL DOWN BUTT TOWARDS</i>		<i>BLADE DOWN EDGE TOWARDS</i>
15		<i>BARREL DOWN BUTT AWAY</i>		<i>BLADE DOWN EDGE AWAY</i>
16		<i>BARREL DOWN BUTTRIGHT</i>		<i>BLADE DOWN EDGE RIGHT</i>
17		<i>BARREL AWAY BUTT DOWN</i>		<i>BLADE AWAY EDGE DOWN</i>
18		<i>BARREL AWAY BUTT UP</i>		<i>BLADE AWAY EDGE UP</i>
19		<i>BARREL AWAY BUTTRIGHT</i>		<i>BLADE AWAY EDGE RIGHT</i>
20		<i>BARREL AWAY BUTTLEFT</i>		<i>BLADE AWAY EDGE LEFT</i>
21		<i>BARREL TOWARDS BUTTRIGHT</i>		<i>BLADE TOWARDS EDGE RIGHT</i>
22		<i>BARREL TOWARDS BUTTLEFT</i>		<i>BLADE TOWARDS EDGE LEFT</i>
23		<i>BARREL TOWARDS BUTT UP</i>		<i>BLADE TOWARDS EDGE UP</i>
24		<i>BARREL TOWARDS BUTT DOWN</i>		<i>BLADE TOWARDS EDGE DOWN</i>

FIG. 2 Test Object Orientation

8.4 Divide the critical test object signal by the possessions signal to obtain the discrimination ratio. Record this ratio in the evaluation report.

8.5 The entire set of possessions in 15.1.2 is suitable for testing many weapons detectors. Where a detector is to be used for small objects, larger items in the set shall be deleted until

the signal from the possessions array is smaller than the signal from the smallest test object (see 15.1.2).

9. Procedure for Determining the Peak-Induced Electromagnetic Field

9.1 With the detector generating its normal detection field, use the induced electromagnetic field test probe in 15.2 to examine the volume described by the two dimensions of the detector opening and the width of the detector in the passage direction. No portion of the probe shall be closer than 200 mm (8 in.) to any side wall or side-defining structural member. Locate the position and orientation of the test probe which produces the maximum induced potential. Record the shape of the waveform and the peak-to-peak value.

9.2 For a sinusoidal waveform, the peak-to-peak field in μT is:

$$\mu T = 0.312V(T) \quad (1)$$

where:

V = induced peak-to-peak potential (mV),
 T = period, ms, and
 $100 \mu\text{T} = 1 \text{ G}$.

9.3 For a non-sinusoidal field, integrate the induced waveform using an RC integrator with a time constant such that $\omega RC \gg 1$ for the lowest measured frequency. The peak-to-peak field in μT is:

$$\mu T = 1.97 (R) (C) (V_o) \quad (2)$$

where:

ω = $6.28 \times$ frequency, Hz,
 R = resistance, $\text{M } \Omega$,
 C = capacitance, μF , and
 V_o = peak-to-peak output of RC integrator, V.

Potential amplification will be necessary. As a compromise between integration and amplification, a R-C time constant of 0.01 s has been used at pulse rates in the 200 to 300-Hz region with acceptable results.

9.4 The detector shall have an alarm to alert the operator in case a component or other failure accidentally produce electromagnetic fields below the level of the detector function.

10. Conditions Applicable to Outside Influence Tests

10.1 Tests in 11.2, 12.1, and 12.2 require measurement of detector sensitivity. For the other tests, the detector shall be in its “actively detecting” mode and operating at the critical sensitivity setting in 7.7.7.

10.2 Except for 12.1 (power supply variation), conduct all tests at the manufacturer’s nominal nameplate power supply potential.

10.3 Some detectors have passive provisions for combatting outside influences, such as shields or shielded portals. When the shielding is removable, make measurements with and without shield and record two sets of data to show the effects of these provisions.

10.4 For detectors that are not symmetrical from side to side, record data for each side.

10.5 For detectors with more than one channel generating a detection signal, recorded results shall reflect the most adverse findings with respect to outside influences.

10.6 For detectors with optional operating modes, record additional sets of data to show the effects of the different modes.

10.7 For detectors which do not have electronics packages integral with the structure, repeat all distance-related tests with relation to the electronics package in its remote placement. Record the least-favorable data.

11. Procedure for Testing for Outside Influences: Mechanical

11.1 Influence of Moving Metal Objects:

11.1.1 A clean tester shall carry the test object as described in 15.4, simulating a metallic briefcase outside the portal structure in a path parallel to normal passage flow at a height of 200 mm (8 in.) from its bottom edge to the floor and again at a height of 1.5 m (60 in.) from the floor.

11.1.2 Conduct the test for each portal side; determine the maximum distance between the test probe and the detector, which can generate an alarm at the critical sensitivity setting. Record this distance for each side on the evaluation report.

11.2 Influence of Reinforcing Steel in Concrete Floors:

11.2.1 Place the detector on the reinforcing-bar (re-bar) apparatus as described in 15.5.

11.2.2 Repeat the test procedure in Section 7 for grid locations near the floor to determine the change in detection caused by the presence of the re-bar. Report the general effects. If there is a detection decrease, determine and record the re-bar to test object distance at which such decrease is 10 % or less.

12. Procedure for Testing for Outside Influences: Electrical Power Line

12.1 *Supply Potential Variation*—This test determines the change of detector sensitivity as the power supply potential changes.

12.1.1 Vary the line power supply potential between the nominal potential minus 15 % and the nominal potential plus 15 %, unless the manufacturer’s nameplate or specifications state a narrower range of line power supply potential. In such cases, use the lesser range and so note on the evaluation report.

12.1.2 The means used to vary the line power supply potential shall have a low impedance to avoid clipping of potential or current waveforms; some variable autotransformers, among other devices, can cause this clipping.

12.1.3 Test the detector sensitivity for the critical test object in the critical orientation at the critical test point at nominal supply potential, repeating the test recorded in 7.7.7. Determine and record the change in detector sensitivity at each potential extreme with respect to nominal line potential after the detector has operated for 30 min at that potential extreme.

12.1.4 If a detector is to be operated from an auxiliary power source different from line power (such as a motor-generator, uninterruptible power supply or a battery), perform the following tests as appropriate.

12.1.4.1 Determine and record the variation of detector sensitivity caused by the maximum specified variation in

frequency of the auxiliary power source while operating at its nominal operating potential.

12.1.4.2 When a battery is used, record the sensitivity with a fully charged battery and then after the battery has operated for the manufacturer’s specified maximum battery operating time.

12.2 *Low-Level-Conducted Noise*—This test determines the change in the ambient signal caused by typical electrical noise injected through power line conduction.

12.2.1 To avoid radiated noise, all apparatus used for this test shall be located remotely from the detector. Detector power shall be run from the apparatus to the detector through a grounded metal conduit.

12.2.2 Power the detector through the line impedance stabilization network of 15.6 and use the conducted noise isolation filter of 15.7 to measure both line-neutral noise and line-ground noise in accordance with Fig. 3. Use an oscilloscope to read the ambient noise levels and record these levels in the evaluation report.

12.2.3 Although the detector is operating at the critical sensitivity as measured previously in 7.7.7, the line impedance stabilization network may change the detector ambient signal level. Reread and record the signal.

12.2.4 Connect the silicon-controlled rectifier (SCR) noise source as described in 15.8 to the detector power. Read and record the change in the detector ambient signal level, the line-to-neutral generated noise, and the line-to-ground generated noise.

12.2.5 Repeat the test of 12.2.4 by removing the SCR noise source and connecting the switching power supply noise source of 15.9. Read and record the change in the detector ambient signal level, the line-to-neutral generated noise, and the line-to-ground generated noise. (**Warning**—The following test involves high currents and high potential. Unless the manufacturer states that the metal detector can tolerate such conditions, *Do Not Perform This Test*. If the equipment is not designed to withstand these test conditions, it can explosively disintegrate. Follow all safety precautions recommended by the test equipment manufacturer. *Do Not Attempt To Conduct This Test Without Prior Experience*.)

12.3 *High-Level (Lightning) Conducted Noise*—This test determines the effects of a simulated lightning strike injected through power line conduction.

12.3.1 This test is optional to be conducted where detectors may be used under abnormal operating conditions that justify

the associated cost and risk. The necessary test equipment is expensive and not generally available, even in independent testing laboratories.

12.3.2 Subject the detector to the surge potentials and currents recommended in Section 2.1 of ANSI/IEEE C62.41 for Category A. Record any observed physical damage. Repeat the test recorded in 7.7.7. Record any change in sensitivity.

13. Procedure for Testing for Outside Influences: Electrical

13.1 The following tests use the electrical influence test probe specified and connected as described in 15.3 to inject an outside electrical field into a metal detector. The specified voltage levels are measured across the test probe coil.

13.2 For each test, examine the region around the detector portal and electronics, at heights from floor level to 1.5 m (5 ft) above the floor, to determine the worst-case orientation and location of the test probe with respect to the detector. (Close proximity of the probe to the detector is desirable, indicating less effect from the outside interference.) At the critical sensitivity setting, determine the greatest distance between the test probe and the detector at which an alarm is generated. See 10.3 and 10.4 for circumstances that require more than one set of data. Record all distances on the evaluation report.

13.3 *Transient Hum Test*—This test simulates interference from motors or electronic equipment being turned on and off, ground faults, loops of wiring in a building, changes in line, etc.

13.3.1 1 Energize the test probe with an alternately connected and disconnected 6-V RMS signal derived from local line power, using an audio amplifier or a mechanical or electronic switch cycling at a 0.1-Hz rate. Switching need not be synchronous with the line power. A relay switching a transformer secondary is a possibility, provided all components, except the test probe, are shielded from or located remotely from the detector. Fig. 4 is another possible approach for implementing this function.

13.3.2 Determine and record the alarm-generating distance in accordance with 13.2.

13.4 *Noise Spike Test*—This test simulates noise from motor-control triacs, motorized wheelchairs, and electronically controlled heat sources.

13.4.1 Energize the test probe with pulses having a duration of 0.5 ms, a peak amplitude of 15 V, and a repetition rate of 20

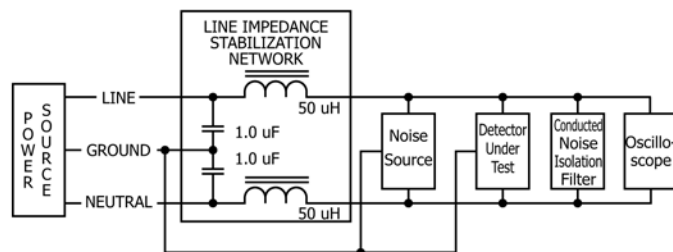

FIG. 3 Configuration for the Low-Level Conducted Noise Test

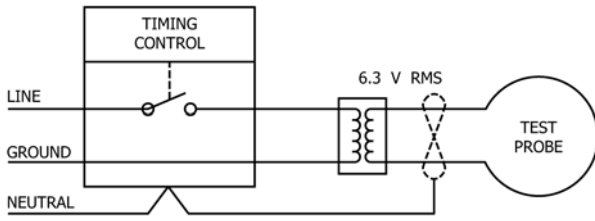

FIG. 4 Suggested Approach for the Transient Hum Test

± 1 Hz. Fig. 5 is a suggested (non-mandatory) approach for implementing this function.

13.4.2 Determine and record the alarm-generating distance in accordance with 13.2.

13.5 *TV Noise Test*—This test simulates the horizontal synchronization from local closed-circuit TV equipment.

13.5.1 Energize the test probe with a rectangular potential waveform having the frequency of the local closed-circuit TV horizontal sweep rate $\pm 5\%$, a $20 \pm 5\%$ duty factor, and a 15-V peak-to-peak amplitude.

13.5.2 Determine and record the alarm-generating distance in accordance with 13.2.

13.6 *Audio Frequency Noise Test*—This test simulates audio noise.

13.6.1 Energize the test probe with pseudo-random noise, filtered at -3 dB per octave from 10 to 40 kHz, at a 10-V RMS level. Fig. 6 is a suggested (non-mandatory) approach for implementing this function.

NOTE 1—Pseudo-random pink noise generator: 80 KHz clock, 23-bit feedback shift register, length = 8 388 607 counts (102 s).

13.6.2 Determine and record the alarm-generating distance in accordance with 13.2.

13.7 *Switching Power Supply Noise Test*—This test simulates noise radiated from a switching-type power supply.

13.7.1 Energize the test probe with a sine or square wave having a center frequency of 40 kHz and frequency modulated by a 1 ± 0.5 -Hz triangular waveform which produces a frequency deviation between 20 and 30 kHz peak-to-peak, driving the test probe at a 15-V peak-to-peak level.

13.7.2 Determine and record the alarm-generating distance in accordance with 13.2.

13.8 *Fluorescent Light Noise Test*—This test simulates the noise influence of fluorescent lighting.

13.8.1 Energize the test probe with an alternately connected and disconnected 6-V RMS signal derived from local line power; this is the same signal used in 13.3.1.

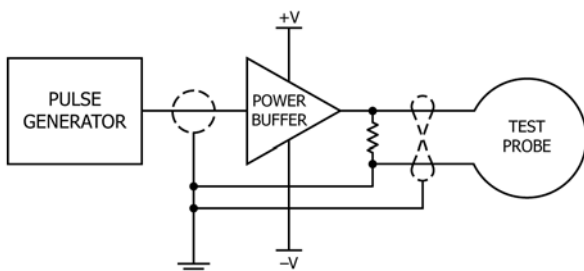
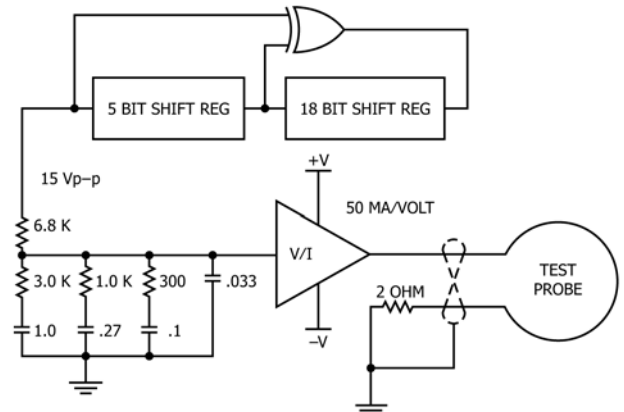

FIG. 5 Suggested Approach for the Noise Spike Test



NOTE 1—Pseudo-random pink noise generator: 80-KHz clock, 23-bit feedback shift register, length = 8 388 607 counts (102 s).

FIG. 6 Suggested Approach for the Audio Frequency Noise Test

13.8.2 Using a nonmetallic stepladder or equivalent, examine the area above the portal and electronics to determine the worst-case orientation and location of the test probe with respect to various elements of the detector and the maximum distance between the test probe and the detector which, under the worst-case conditions, can generate an alarm at the critical sensitivity setting. Record this distance on the evaluation report.

14. Procedure for Testing for Outside Influences: RF Transmission

14.1 The test probes shall be transmitter-receiver radios having a transmitter output between 1 and 10 W and short-loaded antennas. Speaker volumes shall be at a minimum.

14.2 One radio shall operate at 27 ± 3 MHz, amplitude-modulated. Another radio shall operate at 450 ± 100 MHz with frequency modulation.

14.3 Radio-transmitting equipment operating at a different frequency or using a different modulation technique may also be included as an additional test.

14.4 While repeatedly activating the transmit switch, move the transmitter around the detector portal and electronics. Look for the worst-case orientation and location of the radio antenna with respect to the detector. Determine the maximum distance between the closest part of the antenna to the closest part of the detector which can generate an alarm at the critical sensitivity setting. Record this distance for each transmitter on the evaluation report.

14.5 Divide the distances determined for each transmitter in accordance with 14.4 by the square root of the rated RF output power for each transmitter and separately record, as normalized data, on the evaluation report.

15. Specifications and Descriptions of Test Apparatus

15.1 *Metallic Possessions:*

15.1.1 When the objects described in 15.1.2.1 – 15.1.2.10 are carried by a clean tester in the locations shown in Fig. 7, they are a standard array of innocent personal possessions. The

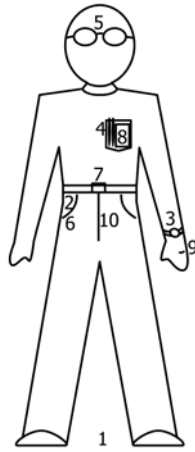

FIG. 7 Possessions Tester

array is used to determine the ability of a detector to discriminate against such objects while detecting a weapon.

15.1.2 If a detector is searching for smaller objects than hand guns, use a subset of these objects. In the absence of any other criteria, removing objects from the top down is appropriate. Record the objects used in the report.

15.1.2.1 *Low-Cut Dress Shoes*, with steel shank or arch support.

15.1.2.2 *Keys (Seven)*—One steel key, 65 mm (2.5 in.) long; two brass house keys, 50 mm (2 in.) long; four brass GM-USA auto or equivalent keys, 50 mm (2 in.) long.

15.1.2.3 *Quartz Watch*, metal case and band.

15.1.2.4 *Two Ball-Point Pens*, stainless steel with gold or chrome plate.

15.1.2.5 *Glasses* with steel frame.

15.1.2.6 *Pocket Change, Loose U.S. Coins*, three quarters, three dimes, four nickels, and five pennies.

15.1.2.7 *Brass Belt Buckle*, open frame/loop type with tang, about 25 by 50 by 3 mm (30 to 40 g).

15.1.2.8 *Cigarette Pack*, foil-lined.

15.1.2.9 *Gold Ring*, wedding band.

15.1.2.10 *Metal Fly Zipper*.

15.2 *Induced Electromagnetic Field Test Probe:*

15.2.1 The probe shall be a round air-core single-layer solenoid coil of 250 turns with a mean coil diameter of 50 mm (2 in.). A 4700 Ω damping resistor shall be connected in series between the coil and the non-ground conductor of the dual-conductor cable of 15.2.3.

15.2.2 The nominal wire size is 0.16 mm (AWG #34); the wire diameter, including insulation, shall be 0.19 mm (0.0075 in.) \pm 10 %.

15.2.3 The coil shall be connected to the measuring instrument with 3 m (10 ft) of dual-conductor cable having an overall shield, RG-108/U or equivalent, with the shield connected only at the instrument.

15.2.4 The measuring instrument, commonly an oscilloscope or electronic voltmeter, shall have an accuracy of \pm 5 % or better over the range of frequencies and amplitudes to be observed. Its input impedance shall be 1 M Ω or greater with less than 30 pF equivalent shunt capacitance.

15.3 *Electrical Influence Test Probe:*

15.3.1 The probe shall be a round air-core single-layer solenoid coil of 38 turns with a mean coil diameter of 200 mm (8 in.).

15.3.2 The nominal wire size shall be 0.51-mm diameter (AWG 24, 0.020 in.).

15.3.3 The leads to the signal source shall be a twisted pair with a twisting pitch less than 100 mm (4 in.).

15.3.4 Adjust the DC resistance to $5.0 \sigma \pm 5 \%$ by connecting a 50-W resistor in series with the coil.

15.4 *Mechanical Influence Test Object*—This probe is a square piece of any common grade of aluminum, 30 by 30 cm (12 by 12 in.) and 1.6 mm (0.062 in.) thick.

15.5 *Floor Platform Containing Concrete Reinforcing Bar:*

15.5.1 The platform containing the *reinforcing bar (re-bar)* shall be at least 300 mm (12 in.) larger than the detector portal.

15.5.2 Using standard 16-mm ($\frac{5}{8}$ -in.) diameter deformed steel reinforcing bar, place a layer of parallel bars, spaced 300 mm (12 in.) apart, on a suitable platform substrate. Place a second layer, separated from the first by 3 mm ($\frac{1}{8}$ in.), directly above and at right angles to the first layer. The platform and individual bars should be fastened so they do not move during use.

15.5.3 Support a walking bridge for the tester with blocks between the openings in the re-bar such that the bridge never touches the re-bar or its platform. This bridge shall have a 6-mm ($\frac{1}{4}$ -in.) clearance to the upper re-bar layer and shall be 20 mm ($\frac{3}{4}$ in.) thick. Bridge extensions (without re-bar) shall be provided so that the tester can step up outside the detector, walk through, and come to a stop before leaving the bridge level. The bridge and supports shall not contain any significant metal components.

15.5.4 The detector shall be supported by another set of blocks between the re-bar openings. When a tester walks through the detector on the bridge, there must not be any resultant motion of either the detector or the re-bar for the test to be valid.

15.6 *Line Impedance Stabilization:*

15.6.1 A low-pass filter shall be used between the detector under test and its source of electrical power to block and standardize the absorption of the injected conducted noise by the power source and wiring.

15.6.2 The filter shall consist of 1.0 μ F input capacitors from line and neutral to ground, followed by 50 μ H RF “hash” chokes in series with the line and neutral leads in accordance with Fig. 3.

15.7 *Conducted Noise Isolation Filter:*

15.7.1 A high-pass filter shall be used to view and adjust the amplitude of the deliberately generated conducted noise. This filter shall have a minimum pass band of 6 KHz to 5 MHz; there may be a known and constant amplitude attenuation up to 20 db.

15.7.2 Power line frequencies of 50/60 Hz shall be attenuated at least 55 db.

15.7.3 One or more cascaded R-C stages may be used for this filter.

15.8 *Conducted Noise Generator, SCR/Triac Waveform:*

15.8.1 An incandescent lamp dimmer (silicon-controlled rectifier—triac type) having a nominal rating of 600 W shall be connected in series with two 100-W light bulbs across the line and neutral wires of the detector under test. The dimmer shall be a residential type with minimal or no RFI suppression. The metal front plate shall be connected to the power line ground wire.

15.8.2 The firing angle of the dimmer may be adjusted to maximize the noise voltage as measured with the filter described in 15.7.

15.9 *Conducted Noise Generator, Switching Power Supply Waveform*—A switching power supply, rated at approximately 250 W and operating at a switching frequency of approxi-

mately 50 to 75 kHz, shall be loaded to an output of 220 W and placed across the line and neutral wires of the detector under test. The frame of the power supply chassis shall be connected to the power line ground wire.

16. Report

16.1 Fig. 8 depicts the recommended report format.

17. Keywords

17.1 controlled access screening; controlled access search; metal detector; metal detector evaluation; metal object detector; metallic weapons detector; walk-through metal detector; weapons detector; weapons detector evaluation



- 1. Identification
 - Manufacturer _____
 - Address _____
 - Model _____ Serial Number _____
 - Program/Modes Evaluated _____
 - Date _____ Evaluator _____
- 2. Safety
 - 5.2 Mechanical Hazards _____
 - 5.3 Electrical Hazards _____
 - 5.4 Tip: Portal Moment _____ Accessory Moment _____
- 3. Testing Site Requirements
 - 6.1–6.4 Deviations _____
- 4. Detection Capability
 - 7.2 Test Objects in Group _____
 - 7.7.7 Critical Test Object _____
 - 7.7.7 Critical Orientation _____
 - 7.7.7 Critical Location _____
 - 7.7.7 Critical Sensitivity Setting _____
 - 7.7.8 Ambient Signal Level _____
 - 7.7.9 Clean Tester Signal Level _____
 - 7.7.10 % Change, 0.9 to 0.5 m/s _____
 - 7.7.10 % Change, 0.9 to 1.3 m/s _____
- 5. Metallic Discrimination
 - 8.4 Ratio, Test Object/Possessions _____
 - 8.5 Possessions Used: _____
- 6. Peak Induced Magnetic Field
 - 9. Field Waveform _____
 - 9.1 Peak-to-Peak Field, millivolts _____
 - 9.2/3 Peak-to-Peak Field, uTesla _____
 - 9.4 Hi/Lo Field Alert? _____
- 7. Mechanical Outside Influences
 - 11.1.3 Portal-to-Moving Metal Distance, Best Side _____
 - 11.1.3 Portal-to-Moving Metal Distance, Worst Side _____
 - 11.2.2 Basic Rebar Effect _____
 - 11.2.2 Rebar-to-Test Object Distance, 10% Decrease _____
- 8. Electrical Power Line Influences
 - 12.1.1 Voltage Variation, % _____
 - 12.1.3 Sensitivity Change at High Voltage, % _____
 - 12.1.3 Sensitivity Change at Low Voltage, % _____
 - 12.1.4.1 Frequency Variation _____
 - 12.1.4.1 Sensitivity Change Due To Freq Var, % _____
 - 12.1.4.2 Sensitivity, Fully Charged Battery _____
 - 12.1.4.2 Sensitivity, End of Battery Charge _____
 - 12.2.2 Ambient Noise, L-N _____ L-G _____
 - 12.2.3 Signal From Ambient Electrical Noise _____
 - 12.2.4 SCR Noise, L-N _____ L-G _____
 - 12.2.4 Signal From SCR Noise _____
 - 12.2.5 Switching PS Noise, L-N _____ L-G _____
 - 12.2.5 Signal From Switching PS Noise _____
 - 12.3.3 Lightning Strike Physical Damage _____
 - 12.3.3 Lightning Strike, Sensitivity Change, % _____
- 9. Electrical Outside Influences
 - 13.3 Transient Hum, Best Side Max Alarm Distance _____
 - 13.3 Transient Hum, Worst Side Max Alarm Distance _____
 - 13.4 Noise Spike, Best Side Max Alarm Distance _____
 - 13.4 Noise Spike, Worst Side Max Alarm Distance _____
 - 13.5 TV Noise, Best Side Max Alarm Distance _____
 - 13.5 TV Noise, Worst Side Max Alarm Distance _____
 - 13.6 Random AF Noise, Best Side Max Alarm Distance _____
 - 13.6 Random AF Noise, Worst Side Max Alarm Distance _____
 - 13.7 Switch PS Noise, Best Side Max Alarm Distance _____
 - 13.7 Switch PS Noise, Worst Side Max Alarm Distance _____
 - 13.8 Fluorescent Light, Best Side Max Alarm Distance _____
 - 13.8 Fluorescent Light, Worst Side Max Alarm Distance _____
- 10. RF Transmission Influences
 - 14.4 AM Transmitter, Maximum Alarming Distance _____
 - 14.4 FM Transmitter, Maximum Alarming Distance _____
 - 14.5 AM Xmit Power _____ Normalized Distance _____
 - 14.5 FM Xmit Power _____ Normalized Distance _____
- 11. Expand for alternate configurations and modes of operation where applicable.

FIG. 8 Recommended Report Format



F1468 – 04a (2010)

ASTM International takes no position respecting the validity of any patent rights asserted in connection with any item mentioned in this standard. Users of this standard are expressly advised that determination of the validity of any such patent rights, and the risk of infringement of such rights, are entirely their own responsibility.

This standard is subject to revision at any time by the responsible technical committee and must be reviewed every five years and if not revised, either reapproved or withdrawn. Your comments are invited either for revision of this standard or for additional standards and should be addressed to ASTM International Headquarters. Your comments will receive careful consideration at a meeting of the responsible technical committee, which you may attend. If you feel that your comments have not received a fair hearing you should make your views known to the ASTM Committee on Standards, at the address shown below.

This standard is copyrighted by ASTM International, 100 Barr Harbor Drive, PO Box C700, West Conshohocken, PA 19428-2959, United States. Individual reprints (single or multiple copies) of this standard may be obtained by contacting ASTM at the above address or at 610-832-9585 (phone), 610-832-9555 (fax), or service@astm.org (e-mail); or through the ASTM website (www.astm.org). Permission rights to photocopy the standard may also be secured from the Copyright Clearance Center, 222 Rosewood Drive, Danvers, MA 01923, Tel: (978) 646-2600; <http://www.copyright.com/>