



Standard Test Method for Determining the Tribocharge of Two-Component Developer Materials¹

This standard is issued under the fixed designation F1425; the number immediately following the designation indicates the year of original adoption or, in the case of revision, the year of last revision. A number in parentheses indicates the year of last reapproval. A superscript epsilon (ϵ) indicates an editorial change since the last revision or reapproval.

1. Scope

1.1 This test method describes a technique for measuring the tribocharge or charge-to-mass ratio of a sample of developer material.

1.2 This test method determines the concentration of toner in a sample of developer material.

2. Referenced Documents

2.1 *ASTM Standards*:²

F335 [Terminology Relating to Electrostatic Imaging](#)

3. Terminology

3.1 *Definitions of Terms Specific to This Standard*:

3.1.1 *charge to mass ratio*—the quantity of charge per unit of mass. In xerography, the tribocharge per unit of mass of the toner.

3.1.2 *tribocharge*—the general term for the electric charge of a material whose charge is created by the tribo electric effect, or the rubbing of unlike surfaces together.

3.2 Terms and definitions used in this test method may be found in Terminology F335.

4. Summary of Test Method

4.1 Two component developer materials used in the xerographic process are charged by the tribo electric effect. Xerographic developers are commonly made up of two materials: toner and carrier. Toners are typically under 38 μm in size while carriers are several times larger. This size difference is used in the measurement of tribocharge.

4.2 The sample cell contains a very fine screen (400 mesh), which allows toner to pass through and blocks carrier from

passing through. The sample cell is held in an insulated block with an electrical connection between the sample cell and the electrometer. The electrometer measures the charge on the cell as the toner is blown off the carrier by a highpressure air stream. From the difference in weight of the cell before and after the blow-off, and the electrometer charge measurement, the charge to mass ratio and percent toner concentration of the developer material can be calculated.

5. Significance and Use

5.1 This test method measures a fundamental property of a toner and developer mix used in copiers and printers. This test method is used for quality control purposes and to determine the ability of the toner and developer materials to develop onto the photoreceptor.

5.2 This test method may be used to measure the charge-to-mass ratio of new developer mixes.

5.3 This test method may be used to measure the charge-to-mass ratio of developer material samples taken from a machine.

5.4 This test method may be used to measure the toner concentration of new developer mixes.

5.5 This test method may be used to measure the toner concentration of developer material samples taken from a machine.

6. Interferences

6.1 Any differences in this test method used to charge the toner that would effect the frequency of collisions of toner and carrier, such as rolling the container of developer material in a container of different size or at a different rate, may cause variation in the results.

6.2 Any differences in the material that the container used to roll the developer material is made from could cause variations in the results.

6.3 The environmental conditions (temperature, humidity) can effect the results because some toners and carriers absorb water onto their surfaces. The water content of the compressed air can effect the results for hygroscopic materials.

¹ This test method is under the jurisdiction of ASTM Committee F05 on Business Imaging Products and is the direct responsibility of Subcommittee F05.04 on Electrostatic Imaging Products.

Current edition approved Oct. 1, 2011. Published September 2012. Originally approved in 1992. Last previous edition approved in 2006 as F1425-06. DOI: 10.1520/F1425-06R11.

² For referenced ASTM standards, visit the ASTM website, www.astm.org, or contact ASTM Customer Service at service@astm.org. For *Annual Book of ASTM Standards* volume information, refer to the standard's Document Summary page on the ASTM website.

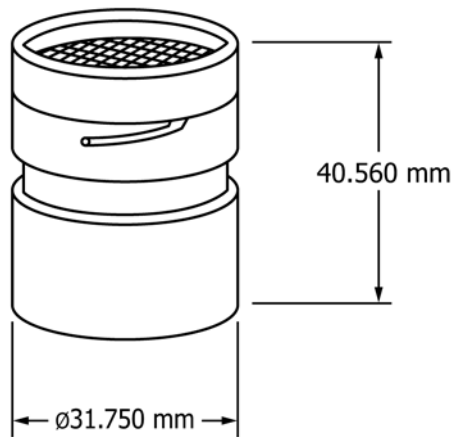

FIG. 1 Sample Cell

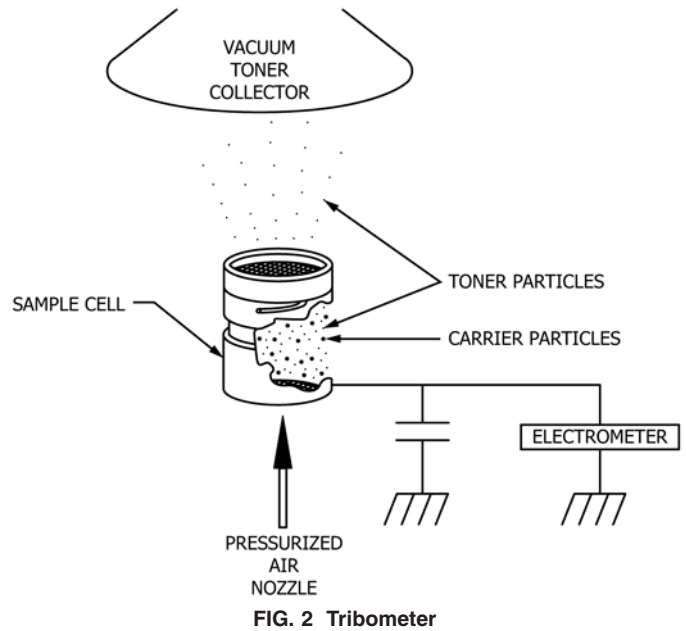

FIG. 2 Tribometer

6.4 The 400-mesh screen of the sample cell can become clogged with material. This is indicated by increasing cell weights. The clogged screen may be able to be cleaned by running a test with the cell empty or by blowing filtered air through the cell from a hand-operated nozzle. If the cell weights indicate that the cell is still clogged, the cell can be cleaned in an ultrasonic cleaner. Be sure the cell is rinsed and dried before use.

6.5 The 400-mesh screen can develop holes or gaps after repeated use. This is evidenced by high percent toner values indicating that the carrier particles have passed through the fine screen, giving lower after blow-off cell weights.

7. Apparatus

7.1 *Sample Cell*— The sample cell contains a very fine screen (400 mesh) supported by a coarse screen. The fine screen allows toner to pass through and blocks carrier from passing through. See Fig. 1.

7.2 *Tribometer*, any device which provides the functions of holding the cell in the proper electrical connection, blowing the air through the cell under controlled conditions of air pressure and time, and collecting the waste toner. See Fig. 2.

7.3 *Vacuum Cleaner*, of a type used in copier service suitable for removal of toner (fine particle filter).

NOTE 1—The hose should be made of material which is resistant to toner, if possible. The vacuum cleaner is used to remove the waste toner.³

7.4 *Electrometer*, capable of measuring charge in the range from 10^{-8} to 10^{-6} C.⁴

³ The sole source of supply of the apparatus (vacuum cleaner 3M Model 496 A G) known to the committee at this time is 3M, 3M Center, St. Paul, MN 55144-1000. If you are aware of alternative suppliers, please provide this information to ASTM International Headquarters. Your comments will receive careful consideration at a meeting of the responsible technical committee,¹ which you may attend.

⁴ The sole source of supply of the apparatus (Keithley 610C electrometer) known to the committee at this time is Keithley Instruments Inc., 28775 Aurora Road, Cleveland, OH 44139. If you are aware of alternative suppliers, please provide this information to ASTM International Headquarters. Your comments will receive careful consideration at a meeting of the responsible technical committee,¹ which you may attend.

7.5 *Air Supply Line*, capable of supplying air at a minimum flow rate of 1.6 to 2.0 ft³/min at 100 psi. The air supplied must be filtered to be free of particulate matter as well as oil (most industrial air systems supply air which includes a minute amount of oil used as a lubricant in air-operated equipment). A5- μ m pre-filter and oil coalescing filter will remove particles and oil. Either the air supply line, or the tribometer unit must include an air-pressure regulator.

7.6 *Analytical Balance*, capable of weighing the cell (approximately 85 g) to 0.0001 g.

7.7 *Roller Unit*— A two-roll device where one roll is powered by a motor. The sample container is placed on the two rollers such that when the roller is powered, the sample container rolls on top of the two rollers. The roller unit should be capable of rolling several sizes of containers of developer, and have a variable speed motor with enough torque to roll samples, or developer mixed of weights appropriate to the application. See Fig. 3.

8. Sample Preparation

8.1 Roll commercially prepared developer mixes or previously prepared large batches for at least 30 min at the appropriate speed for the size of the container.

8.2 Roll freshly made large batches for at least 4 h at the appropriate speed for the size of the container.

8.3 Prepare small carrier/toner samples (approximately 100 g) in a glass jar and roll for at least 1 h at the appropriate speed for the size of the container.

8.4 Run samples taken from a copy machine as soon as possible. Take the sample after the machine has been turning the developer unit for at least 10 min, so that the toner has had an opportunity to tribocharge.

8.5 All speeds are relative to the container size. The actual surface speed of the containers in all cases is approximately 90 ft/min.

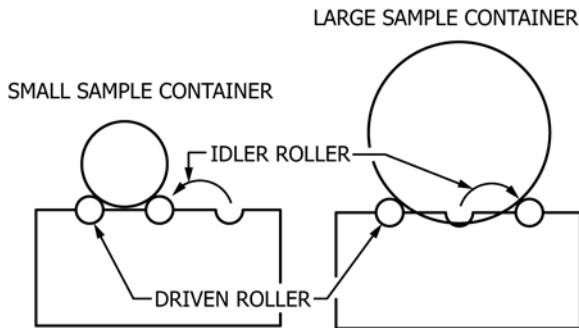
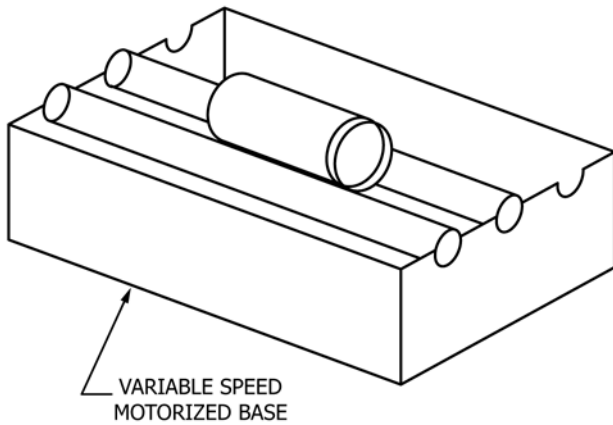

FIG. 3 Roller Unit

9. Calibration

9.1 Initially, make a series of measurements of a developer material to determine the sample size, air pressure, and time required to completely remove the toner from the carrier for the tribometer device being used. Use these standard conditions for all similar samples. For typical negative toners, a 3-g developer sample requires 60 psi of air pressure for 120 s yielding charge-to-mass ratios of 5 to 25 $\mu\text{C/g}$ for 3 to 4 % toner concentration.

9.2 On a regular basis, such as every 20 samples, or after the instrument has not been used for more than one month, check the instrument by measuring the charge-to-mass ratio and toner concentration of a known developer mix. Any differences in the measurements of the known developer mix could indicate the need for maintenance.

9.3 Test the fit of the new screens by performing a test with only carrier material in the cell. The before and after cell weights should be the same if the screens have been properly installed. This procedure can also be used to verify that screens need to be replaced.

10. Procedure

10.1 Set the electrometer controls as follows:

10.1.1 *Polarity*, + or – as required. (Meter polarity depends on material.)

10.1.2 *Range*, from 10^{-6} to 10^{-8} C.

10.1.3 Refer to the electrometer’s instruction manual for detailed operating instructions.

Sample Identification _____	
A. Weight of Empty Cell	_____ g
B. Weight of Cell and Developer	_____ g
C. Weight of Cell After Test	_____ g
D. Electrometer Reading	_____ $\times 10^{-7}$ C
E. Weight of Developer (B-A)	_____ g
F. Weight of Toner (B-C)	_____ g

CALCULATION OF CHARGE TO MASS RATIO (Q/M)

$$Q/M = -D/10F = \mu\text{C/g}$$

CALCULATION OF APPARENT TONER CONCENTRATION

$$(F/E) \times 100 = \% \text{ Toner}$$

FIG. 4 Sample Data Sheet

10.2 Install the vacuum cleaner hose where appropriate to remove the waste toner.

10.3 Set the pressure reducer valve so that the air pressure through the cell is 60 psi.

10.4 Set the tribometer instrument to deliver the air for a set time period. A typical negative toner requires 120 s to remove the toner from the carrier. The time required can be determined by repetitive measurements of the same sample. When no additional weight loss is detected, the time to remove all the toner from the sample has been determined.

10.5 Weigh the clean cell on an analytical balance to the nearest 0.0001 g. Record the weight under Item A on the data sheet.

10.6 Add enough developer material so that the amount of toner expected to be in the sample is large enough to be weighed accurately. Typically, approximately 3 g of developer is added to the cell and reweighed. Record this weight under Item B on the data sheet.

10.7 Assemble the cell, taking care not to lose any material.

10.8 Place the cell in the cell holder and close the unit.

10.9 Ready the electrometer controls.

10.10 Turn on the vacuum cleaner, and then turn on the air supply. The electrometer should show an immediate response. Turn off the air and vacuum cleaner after the appropriate time period if the tribometer does not automatically shut them off.

10.11 When the test is complete, record the electrometer reading on the data sheet under Item D. Note that the electrometer measures the residual charge on the cell after the charged toner is removed. The electrometer reading will be opposite in sign to the charge on the toner.

10.12 Open the unit, remove the cell. Do not clean off the residual toner on the surface of the cell. Weigh the cell. Record this weight under Item C on the data sheet.

10.13 Open the cell, empty it out, and holding both halves so that the open ends are facing down, bang the halves together to remove the last traces of material. Alternatively, blow air through the cell halves. The cell is clean when it weighs the same as the empty weight (A) on the data sheet.

11. Calculation

11.1 Calculate the charge-to-mass ratio (Q/M) as follows:

$$Q/M = -D/10F = \mu\text{C/g}$$

where $F = B - C$.

11.2 Calculate the apparent toner concentration as follows:

$$(F/E) \times 100 = \% \text{ toner}$$

where $E = B - A$.

12. Interpretation of Results

12.1 For any two component developer samples, the tribocharge (charge-to-mass ratio) is created by the frictional rubbing of the toner and carrier surfaces. The sample preparation plays an important role in the measured tribocharge value. Samples must be allowed to fully charge before the measurement is performed or false low values will result. Additionally, when comparing two samples, their charging history must be taken into account.

12.1.1 For two component developers, tribocharge is a function of the concentration of toner in the developer sample. At very high toner concentrations, there is more toner than the surface of the carrier can interact with. This condition leads to lower tribocharge values.

12.2 The quality of a used developer can be inferred from a comparison of the tribocharge value of the test developer and the tribocharge value of a fresh developer at the same concentration.

12.2.1 If both samples are similarly prepared, a lower tribocharge value could indicate that the used developer's carrier is partially impacted with toner, thereby reducing the carrier surface area that can participate in charging. A higher tribocharge value, accompanied by lower print density could indicate that the used developer is contaminated with a substance that can effectively compete with the toner at development.

12.2.2 If the used developer sample was charged in a developer unit, and the fresh developer sample was charged by rolling, a lower tribocharge value for the used sample could also indicate that the developer unit does not provide adequate mixing.

13. Precision and Bias

13.1 Repeated measurements of the same developer sample, measured over many days in one laboratory gives a standard deviation of 0.62 $\mu\text{C/g}$ for a charge-to-mass ratio of 12.60 $\mu\text{C/g}$, and 0.35 for a percent toner of 3.48 %.

14. Keywords

14.1 developer; tribo; tribocharge; two components

ASTM International takes no position respecting the validity of any patent rights asserted in connection with any item mentioned in this standard. Users of this standard are expressly advised that determination of the validity of any such patent rights, and the risk of infringement of such rights, are entirely their own responsibility.

This standard is subject to revision at any time by the responsible technical committee and must be reviewed every five years and if not revised, either reapproved or withdrawn. Your comments are invited either for revision of this standard or for additional standards and should be addressed to ASTM International Headquarters. Your comments will receive careful consideration at a meeting of the responsible technical committee, which you may attend. If you feel that your comments have not received a fair hearing you should make your views known to the ASTM Committee on Standards, at the address shown below.

This standard is copyrighted by ASTM International, 100 Barr Harbor Drive, PO Box C700, West Conshohocken, PA 19428-2959, United States. Individual reprints (single or multiple copies) of this standard may be obtained by contacting ASTM at the above address or at 610-832-9585 (phone), 610-832-9555 (fax), or service@astm.org (e-mail); or through the ASTM website (www.astm.org). Permission rights to photocopy the standard may also be secured from the Copyright Clearance Center, 222 Rosewood Drive, Danvers, MA 01923, Tel: (978) 646-2600; http://www.copyright.com/