



## Standard Practice for

# Making Reference Glass-Metal Butt Seals and Testing for Expansion Characteristics by Polarimetric Methods<sup>1</sup>

This standard is issued under the fixed designation F140; the number immediately following the designation indicates the year of original adoption or, in the case of revision, the year of last revision. A number in parentheses indicates the year of last reapproval. A superscript epsilon ( $\epsilon$ ) indicates an editorial change since the last revision or reapproval.

### 1. Scope

1.1 This practice covers the preparation and testing of reference glass-metal butt seals of two general configurations: one applicable to determining stress in the glass and the other to determining the degree of mismatch of thermal expansion (or contraction). Tests are in accordance with Test Method **F218** (Section 1.1).

1.2 This practice applies to all glass and metal (or alloy) combinations normally sealed together in the production of electronic components. It should not be attempted with glass-metal combinations having widely divergent thermal expansion (or contraction) properties.

### 2. Referenced Documents

#### 2.1 *ASTM Standards*:<sup>2</sup>

**F47 Test Method for Crystallographic Perfection of Silicon by Preferential Etch Techniques** (Withdrawn 1998)<sup>3</sup>

**F79 Specification for Type 101 Sealing Glass**

**F105 Specification for Type 58 Borosilicate Sealing Glass**

**F218 Test Method for Measuring Optical Retardation and Analyzing Stress in Glass**

### 3. Summary of Practice

3.1 Five seals of a standard configuration are prepared from representative specimens of the glass and metal to be tested. The glass and metal are cleaned, treated, and sized to specified proportions. Plane-interfaced seals are formed, annealed, and measured for residual optical retardation. The stress parallel to the interface in each seal is calculated from the optical

retardation, and the average stress is computed for the sample. For disk-seals the thermal expansion mismatch is calculated.

### 4. Significance and Use

4.1 The term “reference” as employed in this practice implies that either the glass or the metal of the reference glass-metal seal will be a “standard reference material” such as those supplied for other physical tests by the National Institute for Standards and Technology (NIST), or a secondary reference material whose sealing characteristics have been determined by seals to a standard reference material.<sup>4</sup> Until standard reference materials for seals are established by the NIST, secondary reference materials may be agreed upon between manufacturer and purchaser.

### 5. Apparatus

5.1 *Polarimeter*, as specified in Test Method **F218** for measuring optical retardation and analyzing stress in glass.

5.2 *Cut-Off Saw*, with diamond-impregnated wheel and No. 180 grit abrasive blade under flowing coolant for cutting and fine-grinding glass rod.

5.3 *Glass Polisher*, buffing wheel with cerium oxide polishing powder or laboratory-type equipment with fine-grinding and polishing laps.

5.4 *Heat-Treating and Oxidizing Furnaces*, with suitable controls and with provisions for appropriate atmospheres (Annex A1) for preconditioning metal, if required.

5.5 *Sealing Furnace*, radiant tube, muffle or r-f induction with suitable controls and provision for use with inert atmosphere.

5.6 *Annealing Furnace*, with capability of controlled cooling.

5.7 *Ultrasonic Cleaner*, optional.

5.8 *Fixture for Furnace Sealing*, designed as suggested in Annex A2.

5.9 *Micrometer Caliper*, with index permitting direct reading accuracy of 0.02 cm.

<sup>4</sup> See NIST SP 260.

<sup>1</sup> This practice is under the jurisdiction of ASTM Committee **C14** on Glass and Glass Products and is the direct responsibility of Subcommittee **C14.04** on Physical and Mechanical Properties.

Current edition approved Oct. 1, 2013. Published October 2013. Originally approved in 1971. Last previous edition approved in 2008 as F140 – 98 (2008). DOI: 10.1520/F0140-98R13.

<sup>2</sup> For referenced ASTM standards, visit the ASTM website, [www.astm.org](http://www.astm.org), or contact ASTM Customer Service at [service@astm.org](mailto:service@astm.org). For *Annual Book of ASTM Standards* volume information, refer to the standard's Document Summary page on the ASTM website.

<sup>3</sup> The last approved version of this historical standard is referenced on [www.astm.org](http://www.astm.org).

5.10 Immersion Mercury Thermometer.

6. Materials

6.1 *Metal*—Representative specimen pairs of the metal from either rod or plate stock with dimensions satisfying the requirements of 7.2 or 7.3. The surfaces to be sealed should be relatively free of scratches, machine marks, pits, or inclusions that would induce localized stresses. The sealing surfaces should terminate in sharp edges at the peripheral corners to act as a glass stop. Edges that are rounded, such as appear on tumbled parts, will have the tendency to permit glass overflow.

6.2 *Glass*—Representative specimens of rod or plate glass, cut with either diamond-impregnated or other abrasive cutting wheels under flowing water. Dimensions (volume) shall satisfy the requirements of 7.2 or 7.3.

7. Test Specimen

7.1 Two basic cylindrical geometries are considered. For determining only the stress in glass, a seal whose total length is at least twice its diameter must be used. For determining expansion mismatch (as well as stress) a seal whose total thickness is equal to or less than one fifth of its diameter must be used.

7.2 The design for measuring stress provides seals between a cylindrical rod specimen of glass and metal of either rod or sheet (strip) form. The standard rod seal of Fig. 1(a) shall be made from specimens so that the diameter of the metal,  $d_m$  is 0.5 to 1.0 mm larger than the diameter of the glass,  $d_g$ , before the seal is made; the lengths  $l_g$  and  $l_m$  shall each be at least  $d_g$ . The standard sheet seal of Fig. 2(a) shall be made from specimens so that  $l_g$  is at least  $10 l_m$  and  $a$  and  $b$  each exceed  $d_g$  by at least 1.0 mm. In all cases  $d_g$  shall be at least 5.0 mm;  $d$  is defined as the sighting line (or light path) through the glass at the interface after sealing.

7.2.1 Record the dimensions of glass and metal.

7.3 For determining the thermal expansion mismatch between the metal and the glass, the standard disk seal shown in Fig. 3(a) is made. Here  $d_m$  may exceed  $d_g$  by 0.5 to 1.0 mm;

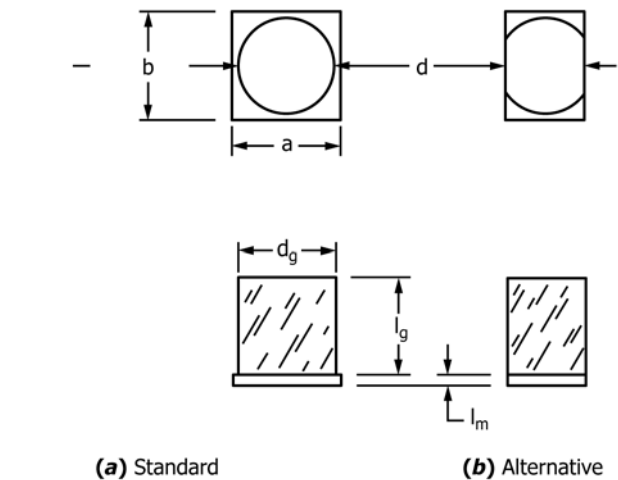

FIG. 2 Sheet Seals

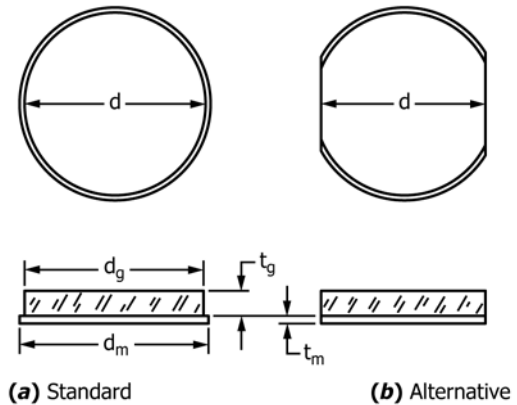

FIG. 3 Disk Seals

$d_g$  shall be at least 10 mm. The metal to glass thickness ratio,  $t_m/t_g$ , may range from  $1/3$  to 1;  $d$  is defined as the sighting line (or light path) through the glass at the interface after sealing and must be at least  $5(t_m + t_g)$ .

7.3.1 Record the dimensions of glass and metal.

8. Preparation of Specimens

8.1 *Metal*—Chemically clean the specimens to remove surface contaminants, especially lubricants and fingerprints from fabrication and handling. Usually it is advisable to preoxidize parts as described in Annex A1. Preoxidation promotes a better glass-to-metal bond and relieves cold-working stresses.

NOTE 1—The cleaned and heat-treated metal should be sealed within 24 h and should be protected from surface contamination during this period.

8.2 *Glass*—Using optical-glass techniques grind and polish the sealing surface of the glass specimens with either wet abrasive wheels or water slurries of abrasive on a lap. The polished surface should be at  $90 \pm 2^\circ$  to the specimen axis and without chips, nicks, or scratches. Remove any surface contaminants which could produce bubbly seals. An ultrasonic wash may be used (Annex A1).

8.3 Measure and record the dimensions (diameter, length, thickness) of each glass and each metal specimen.

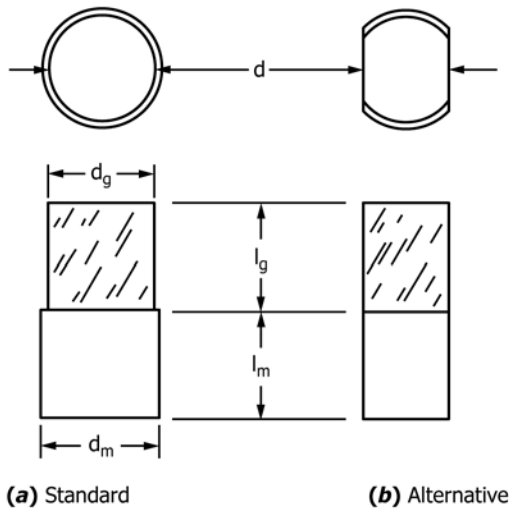

FIG. 1 Rod Seals

## 9. Procedure for Making the Butt-Seal

9.1 Record dimensions of metal plates and glass parts.

9.2 Make the seal in a furnace, by flame, or by induction heating of the metal, utilizing suitable specimen holders or supports under controlled conditions of temperature and time (Annex A2).

## 10. Annealing

10.1 Once a symmetrical, bubble-free seal has been made, proper annealing of the seal becomes the most critical part of the procedure. It is by this operation that all stresses are relieved except those due to the difference in thermal contraction of the two materials from annealing temperature levels. This process involves heating the seal to a temperature somewhat higher than the annealing point of the glass and maintaining the temperature for a time sufficient to relieve the existing strain. The test specimen is then cooled slowly at a constant rate. As an alternative, annealing can proceed directly on cooling during the making of a seal.

10.2 Seal stress and associated expansion mismatch can be varied markedly by annealing schedule modification. For this reason, when the test is used as an acceptance specification, it is strongly recommended that producer and user mutually define the annealing schedule and establish rigid controls for its maintenance.

## 11. Procedure for Measuring Optical Retardation

11.1 For each specimen measure the retardation in the annealed seal due to the stress parallel to the interface according to Test Method F218.

11.1.1 Position the cylindrical axis of the glass (in an immersion liquid, if needed) in a direction  $45^\circ$  from the direction of vibration of the polarizer and analyzer, so that the line of sight or light path lies in the plane of the interface and passes through its center.

11.1.2 Determine the retardation along the light path in terms of degrees of rotation of the analyzer. Rotate the analyzer in a direction that causes the curved black fringe seen within the glass to appear to move up to but not beyond the glass-metal interface (as though into the metal). Rotate the analyzer so that any light or “gray” area which may exist between the darkest part of the fringe (its center of width) and the surface of the metal disappears; this condition is termed “extinction.” When extinction is achieved correctly, the width of the black fringe should appear to be about half its initial value, the other half apparently being obscured by the metal. Record the rotation of the analyzer required to produce extinction.

NOTE 2—Sealing combinations may exist in which the thermal expansion coefficients of glass and metal at room temperature may differ significantly. In these cases it may be important to record the temperature of the refraction liquid (or the seal) at the time the retardation is measured.

NOTE 3—In certain glasses, especially those compositions containing more than one alkali oxide, part of the retardation observed may not be

associated with the mismatch stress of interest. In these cases some structural birefringence is caused by temporary stresses at elevated temperatures. The exact analysis of mismatch stress should be evaluated by completely removing the metal member by acid immersion. The retardation should again be read at the same glass surface. Any residual retardation should then be algebraically subtracted from that previously observed.

NOTE 4—If it is desired to minimize any uncertainties about measuring through the curved surfaces, these may be ground after annealing to conform to the alternate shapes of Fig. 1(b), 2(b), or 3(b). Opposing faces should be ground so as to be parallel to each other and normal to the plane of the seal interface each within  $\frac{1}{2}^\circ$ . For rod seals or sheet seals, grinding should be such that in Fig. 1(b) and 2(b) the dimension  $d$  is not less than  $0.8 d_g$ . In the case of the alternative disk seal of Fig. 3(b),  $d$  must still be at least  $5(t_m + t_g)$ . Grinding should be followed by reannealing before measuring retardation. It should be borne in mind that grinding may produce micro or macro cracks at the interface with the uncertainties associated with these conditions.

11.1.3 If an immersion liquid is used record the nominal index of refraction,  $n_D$ , of the liquid, and measure and record to the nearest  $0.1^\circ\text{C}$  the temperature of the liquid using an immersion mercury thermometer.

11.1.4 Record the type of light source and the effective wavelength,  $L$ , in nanometres of the light for which the retardation has been measured. Record the interface extinction angle and sense (tension or compression) as defined in Test Method F218.

11.1.5 Measure the length  $d$  along the light path (Fig. 1, 2, and 3) using a micrometer caliper with an index permitting direct reading of 0.002 mm.

## 12. Calculations

12.1 Calculate the retardation per unit length of each specimen as follows:

$$R = LA/180d \quad (1)$$

where:

$R$  = retardation per unit length, nm/nm,  
 $L$  = wavelength of light source, nm,  
 $A$  = rotation of analyzer, deg, and  
 $d$  = length of the light path through the interface, nm.

12.2 Calculate the average,  $\bar{R}$ , of the values of  $R$  for the specimens in a test lot.

12.3 For each test lot, calculate the average seal stress parallel to the interface using the relationship:

$$S = \bar{R}/K \quad (2)$$

where:

$S$  = stress parallel to interface, Pa,  
 $\bar{R}$  = average retardation per unit length of the test specimens, nm/nm, and  
 $K$  = stress-optical coefficient of the glass,  $\text{Pa}^{-1}$ .

NOTE 5—The stress-optical coefficient  $K$  of any reference glass shall be supplied by the manufacturer. Values for typical sealing glasses are found in Table A1 of Specifications F79 and F105.

12.4 Calculate the thermal expansion mismatch (or differential thermal contraction of glass and metal between temperatures in the annealing range of the glass and room temperature) for the disk seals using the equation:<sup>5</sup>

$$(\Delta L/L)_T = S(1 - \zeta)/E_g F \quad (\text{Note 6}) \quad (3)$$

where:

- $(\Delta L/L)_T$  = total expansion mismatch between setting point of glass and room temperature, m/m,
- $\zeta$  = Poisson's ratio for glass,
- $F$  = shape-modulus factor  $(kr^4 + 3r^2 + 4r)/(kr^4 + 4r^3 + 6r^2 + 4r + 1/k)$ ,
- $k$  =  $E_m/E_g$ ,
- $E_m$  = Young's modulus for metal, Pa,
- $E_g$  = Young's modulus for glass, Pa,
- $r$  =  $t_m/t_g$ ,
- $t_m$  = thickness of metal, mm, and
- $t_g$  = thickness of glass after sealing, mm.

<sup>5</sup> Ondracek, M., "Magnitude and Distribution of Stresses in Test Seals Used in the Photoelastic Study of Joints Between Two Materials and in the Padmos Test", *Silikaty*, SITKA, Vol 7, 1963, pp. 1-18. (In Czechoslovakian; English translation available from SLA Translation Center, 35 W. 33rd St., Chicago, IL 60616.)

NOTE 6—Use of this equation is valid only if  $d$  is a minimum of  $5(t_m + t_g)$ , the measurement is made at the glass-metal interface, and the

**F VALUES FOR k < 2.0**

k	r				
	1/3	1/2	2/3	5/6	1
1.9	.626	.618	.590	.563	.542
1.8	.620	.613	.586	.559	.538
1.7	.612	.608	.583	.556	.534
1.6	.604	.603	.579	.552	.530
1.5	.595	.597	.574	.548	.526
1.4	.585	.591	.569	.544	.521
1.3	.574	.584	.564	.539	.517
1.2	.561	.576	.558	.534	.511
1.1	.547	.566	.552	.528	.506
1.0	.531	.556	.544	.522	.500
.9	.513	.543	.535	.515	.493
.8	.492	.528	.525	.507	.486
.7	.467	.511	.512	.497	.477
.6	.438	.489	.496	.485	.467
.5	.403	.461	.476	.469	.455
.4	.359	.425	.448	.448	.438
.3	.305	.377	.410	.418	.414
.2	.233	.307	.349	.370	.375
.1	.137	.197	.243	.275	.295

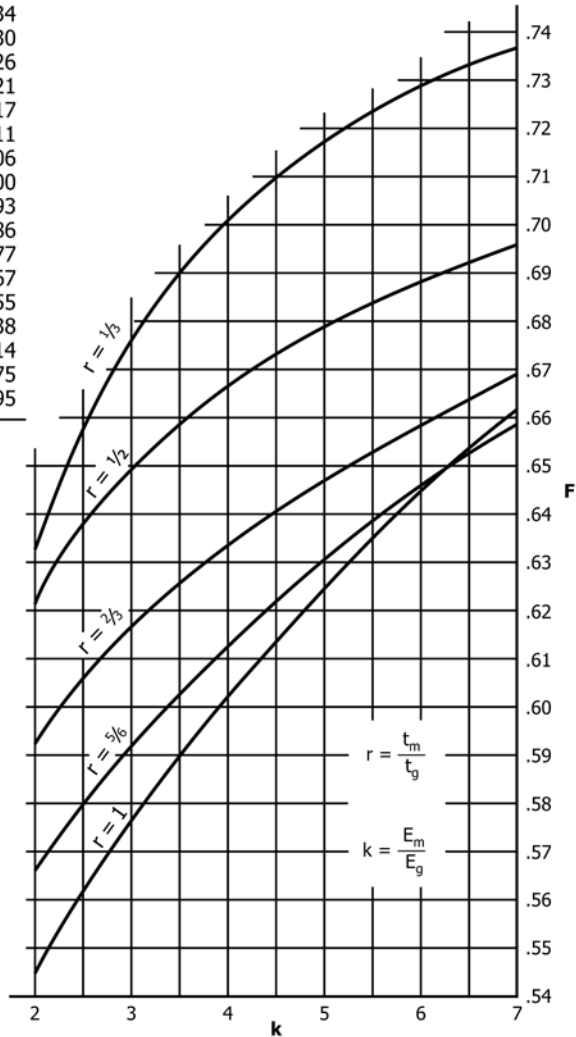

FIG. 4 Shape Modulus Factor, F, for Given Values of r, the Ratio of Thicknesses and k, the Ratio of Young's Moduli, for Determining the Expansion Mismatch in Disk-Seals

unsealed faces of the glass and metal are parallel to the interface within 1°.

12.4.1 The shape-modulus factor,  $F$ , may be estimated from Fig. 4.

### 13. Report

13.1 Report the following information:

- 13.1.1 Type of metal and identification,
- 13.1.2 Type of glass and identification,
- 13.1.3 Diameter and length of glass for each specimen,
- 13.1.4 Diameter and length (or length, breadth, and thickness) of metal rod (or sheet) for each specimen,
- 13.1.5 Average oxide thickness for specimens in a test lot in terms of gain in weight per unit surface area after oxidation,
- 13.1.6 Number of specimens tested,
- 13.1.7 Annealing schedule,
- 13.1.8 Length of the light path through glass at interface for each specimen,

13.1.9 Average and range of calculated retardation per unit length,

13.1.10 Stress-optical coefficient of glass,

13.1.11 Type of light source and effective wavelength,

13.1.12 Nominal index of refraction of immersion liquid and its temperature at the time of retardation measurements or, if no immersion liquid is used, the temperature of the seal,

13.1.13 Average value and sense (tension or compression) of the stress in the glass,

13.1.14 Average thermal expansion mismatch (or differential thermal contraction) between metal and glass in the case of disk-seals, and

13.1.15 Identification of test lot and test data.

### 14. Keywords

14.1 expansion mismatch; glass-metal seals

## ANNEXES

### (Mandatory Information)

#### A1. DIRECTIONS FOR CLEANING AND HEAT-TREATING SPECIMENS OF GLASS AND METAL FOR MAKING SEALS

A1.1 Experience has shown that the directions outlined below should be followed in preparing glass and metal specimens for making seals.

A1.2 Clean the glass with ultrasonic agitation in 0.05 ± 0.01 percent nonionic wetting-agent solution at 50 ± 5 C for 5 ± 1 min. If necessary, precede this by an immersion in a 15 percent aqueous hydrofluoric acid (Note A1.1) solution for 0.5 to 1 min; this is recommended particularly for aged or weathered glass. Rinse successively in distilled or deionized water and alcohol. Blow dry with nitrogen or filtered air, and then oven dry at 100 ± 5 C for 15 ± 2 min. Rinse water (distilled or deionized) shall have a resistivity greater than 2 MΩ-cm.

NOTE A1.1—**Precaution:** See Appendix A1 of Test Method F47 for proper handling of hydrofluoric and hydrochloric acids.

A1.3 Commonly used ASTM sealing alloys are Fe-Ni-Co, Fe-Ni, Ni-Cr-Fe and Cr-Fe (Specifications F15, F30, F31, and

F256). Degrease these alloys in trichloroethylene vapor or liquid, and follow this with the ultrasonic cleaning procedure in A1.2. Rinse in water. Immerse in 10 ± 1 percent hydrochloric acid (Note A1.1) solution at 100 ± 5 C for 2 ± 0.5 min. and follow this with the final rinsing and drying procedure in A1.2.

A1.4 Heat treat Fe-Ni-Co and Fe-Ni alloys in wet (saturated) hydrogen at 1100 ± 20 C for 30 ± 2 min. Then oxidize in air at 800 ± 10 C for 8 ± 2 min. As a result of oxidation Fe-Ni-Co should gain 0.2 to 0.4 mg/cm<sup>2</sup> in weight; Fe-Ni should gain 0.1 to 0.3 mg/cm<sup>2</sup> in weight.

A1.5 Cr-Fe and Ni-Cr-Fe alloys require no prior heat treatment. Oxidize them in wet (saturated) hydrogen at 1200 ± 10 C and 1290 ± 10 C, respectively, for 40 ± 5 min to give a gain in weight of 0.2 to 0.4 mg/cm<sup>2</sup>.



A2. SUGGESTED METHODS FOR MAKING BUTT SEALS

A2.1 For manual sealing with flame, radiant tube, or r-f induction heating, a specimen holder such as that shown in Fig. A2.1 may be employed. Mount the concentric rotating cylindrical holders A and D, made of machineable ceramic or hardened lavite, vertically. Place the metal sheet (or rod) C in the recess of D, over which place the glass B; A centers B on C. The heat source E, of either radiant, r-f, or flame, then effects a seal. The design of A (or B) should be such that a slight but controlled vertical pressure can be induced during sealing. A rocking motion may be found desirable, also.

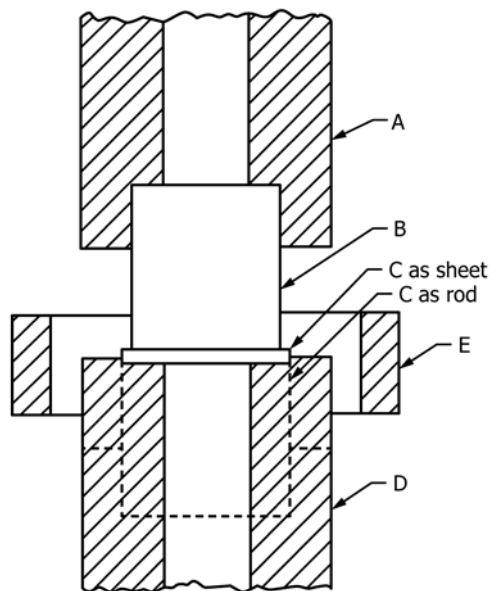

FIG. A2.1 Seal Specimen Holder

A2.2 The temperature-time schedule employed in sealing may be established with a dummy metal (and glass) specimen. The Fe-Ni-Co alloy listed Section 1.1 requires establishment of an optical temperature for the metal sealing surface of 870 to 1010 C prior to glass contact; the other alloys listed require a temperature of 1150 to 1315 C.

A2.3 Heat the glass slowly, either directly or by conduction through the metal specimen surface. When the glass becomes soft (in 10 to 20 s) press the glass and metal sealing surfaces together, slightly, for a period of at least 15 s. If possible exert a gentle rocking motion on the glass cane to provide good wetting of the metal without air entrapment. The glass should not wet beyond the sealing surface of the metal by overflowing down and onto the cylindrical surface (Fig. A2.2).

A2.4 Similar tooling may be employed for furnace sealing. The schedule is dependent on the type of furnace available. Experience indicates, however, that satisfactory seals can be made after an adequate experimental period. To limit further oxidation, an inert atmosphere is recommended.

A2.5 Because of the large diameter-to-length ratio of the disk seal, more sophisticated tooling may be required for making the thermal expansion mismatch specimens. Here it is important that the glass does not deform along its top or cylindrical surface (Note 6). Deformation of the cylindrical surface can be dealt with by resorting to the alternate configuration of Fig. 3(b).



FIG. A2.2 Seal Configurations

ASTM International takes no position respecting the validity of any patent rights asserted in connection with any item mentioned in this standard. Users of this standard are expressly advised that determination of the validity of any such patent rights, and the risk of infringement of such rights, are entirely their own responsibility.

This standard is subject to revision at any time by the responsible technical committee and must be reviewed every five years and if not revised, either reapproved or withdrawn. Your comments are invited either for revision of this standard or for additional standards and should be addressed to ASTM International Headquarters. Your comments will receive careful consideration at a meeting of the responsible technical committee, which you may attend. If you feel that your comments have not received a fair hearing you should make your views known to the ASTM Committee on Standards, at the address shown below.

This standard is copyrighted by ASTM International, 100 Barr Harbor Drive, PO Box C700, West Conshohocken, PA 19428-2959, United States. Individual reprints (single or multiple copies) of this standard may be obtained by contacting ASTM at the above address or at 610-832-9585 (phone), 610-832-9555 (fax), or service@astm.org (e-mail); or through the ASTM website (www.astm.org). Permission rights to photocopy the standard may also be secured from the Copyright Clearance Center, 222 Rosewood Drive, Danvers, MA 01923, Tel: (978) 646-2600; http://www.copyright.com/