



Standard Test Method for Effects of Flame Impingement on Materials Used in Protective Clothing Not Designated Primarily for Flame Resistance¹

This standard is issued under the fixed designation F1358; the number immediately following the designation indicates the year of original adoption or, in the case of revision, the year of last revision. A number in parentheses indicates the year of last reapproval. A superscript epsilon (ϵ) indicates an editorial change since the last revision or reapproval.

1. Scope

1.1 This test method establishes a small-scale laboratory screening procedure for comparing the ignition resistance and burning characteristics of materials used in protective clothing where flame resistance is not the primary form of protection provided by the clothing.

1.1.1 This test method shall not be used in application where flame resistance is the primary form of protection offered by the protective clothing. Other flammability test methods are more appropriate for those materials.

1.1.2 This test method provides a means for comparing ease of ignition and burning behavior of materials which include plastic or elastomeric films, coated fabrics, flexible laminates, multilayer-material systems, or other protective clothing materials that are not designated for offering flame resistance as their primary form of protection.

1.2 This test method is used to measure and describe the response of materials, products, or assemblies to heat and flame under controlled conditions, but does not by itself incorporate all factors required for fire hazard or fire risk assessment of the materials, products, or assemblies under actual fire conditions.

1.3 Fire testing is inherently hazardous. Adequate safeguards for personnel and property shall be employed in conducting these tests.

1.4 The values stated in SI units or other units shall be regarded separately as standard. The values stated in each system are not exact equivalents; therefore, each system must be used independently of the other. Combining values from the two systems may result in non-conformance with the standard.

1.5 *This standard does not purport to address all of the safety concerns, if any, associated with its use. It is the responsibility of the user of this standard to establish appropriate*

and safety and health practices and determine the applicability of regulatory limitations prior to use.

2. Referenced Documents

2.1 *ASTM Standards:*²

[D123 Terminology Relating to Textiles](#)

[D4391 Terminology Relating to The Burning Behavior of Textiles](#)

[D4723 Classification Index of and Descriptions of Textile Flammability Test Methods \(Withdrawn 2016\)](#)³

[D6413 Test Method for Flame Resistance of Textiles \(Vertical Test\)](#)

[F1494 Terminology Relating to Protective Clothing](#)

3. Terminology

3.1 *Definitions*—For definitions of terms used in this test method, related to the combustion of textiles, refer to the terminology contained in Terminology [D4391](#). For definitions of terms used in this test method, related to protective clothing, refer to the terminology contained in Terminology [F1494](#). For definitions of terms used in this test method, related to textile issues, refer to the terminology contained in Terminology [D123](#).

3.2 *afterflame, n*—persistent flaming of a material after the ignition source has been removed.

3.3 *after-flame time, n*—the length of time for which a material continues to flame after the ignition source has been removed.

3.4 *afterglow, n*—a glow in a material after the removal of an external ignition source or after the cessation (natural or induced) of flaming of the material (see also *glow*).

3.5 *anisotropic, adj*—having different values for a specific property in different directions.

¹ This test method is under the jurisdiction of ASTM Committee [F23](#) on Personal Protective Clothing and Equipment and is the direct responsibility of Subcommittee [F23.80](#) on Flame and Thermal.

Current edition approved March 1, 2016. Published April 2016. Originally approved in 1995. Last previous edition approved in 2008 as F1358–08. DOI: 10.1520/F1358-16.

² For referenced ASTM standards, visit the ASTM website, www.astm.org, or contact ASTM Customer Service at service@astm.org. For *Annual Book of ASTM Standards* volume information, refer to the standard's Document Summary page on the ASTM website.

³ The last approved version of this historical standard is referenced on www.astm.org.

3.5.1 *Discussion*—When this test method is used to evaluate textile-based materials, this term refers to warp (wale) and filling (course) directions. When this test method is used for nonwoven materials, this term refers to machine and cross-machine directions.

3.6 *burning behavior, n*—all the changes that take place when materials or products are exposed to a specified ignition source.

3.7 *burn distance, n*—the measurement from the bottom edge of the specimen to the farthest point that shows evidence of damage due to combustion.

3.7.1 *Discussion*—In evaluating the effects of flame impingement of materials used in protective clothing, this measurement applies to the folded material specimen when pressed flat and includes all areas partially burned, charred, embrittled, or melted, but not including areas sooted, stained, distorted, or discolored. Damage due to mechanical delamination or splitting of the specimen is not included in the burn distance unless the delaminated or split area includes damage due to combustion.

3.8 *charring, n*—the formation of carbonaceous residue as the result of pyrolysis or incomplete combustion.

3.9 *combustion, n*—a chemical process of oxidation that occurs at a rate fast enough to produce heat and usually light either as glow or flames.

3.10 *dripping, n*—in testing thermal protective material, a material response evidenced by flowing of the polymer.

3.10.1 *Discussion*—In evaluating the effects of flame impingement of materials used in protective clothing, dripping may be the formation of liquid droplets from melted surface or substrate material during flame impingement.

3.11 *embrittlement, n*—the formation of a brittle residue as the result of pyrolysis or incomplete combustion.

3.12 *flame, n*—as related to ignition of textiles, a controlled hot luminous zone of gas or matter in gaseous suspension, or both, of constant size and shape that is undergoing combustion as evidenced by a low-intensity heat source of less than 1 kW, such as a candle flame or match flame.

3.12.1 *Discussion*—The burner flame in this test method produces relatively low heat flux and should be constant in size and shape.

3.13 *flame impingement, n*—direct contact between a flame and a material.

3.13.1 *Discussion*—In testing flame impingement of materials used in protective clothing, the flame is of a specified type and duration.

3.14 *flammability, n*—those characteristics of a material that pertain to its ignition and support of combustion.

3.14.1 *Discussion*—In evaluating the effects of flame impingement of materials used in protective clothing, flammability is based on the relative number of specimens that ignite when exposed to flame either for a period of 3 or 12 s.

3.15 *glow, n*—visible, flameless combustion of the solid phase of a material.

3.15.1 *Discussion*—Although a solid may glow, it can also produce combustible discharge that will cause a flame. These two phenomena are not necessarily interdependent.

3.16 *ignition, n*—the initiation of combustion.

3.16.1 *Discussion*—In evaluating the effects of flame impingement of material used in protective clothing, ignition is determined by the presence of after-flame after the removal of the burner flame.

3.17 *melting, n*—in testing thermal protective material, a material response evidenced by softening of the polymer.

3.17.1 *Discussion*—In evaluating the effects of flame impingement of materials used in protective clothing, melting may occur at surface layers or in combination with the substrate fabric(s) or other polymer layers. Melting may be observed for protective clothing materials which involve a polymer coating or laminate combined with a normally flame-resistant fabric or substrate.

3.18 *protective clothing, n*—an item of clothing that is specifically designed and constructed for the intended purpose of isolating all or part of the body from a potential hazard; or, isolating the external environment from contamination by the wearer of the clothing.

3.18.1 *Discussion*—In this test method the potential hazard is *flame impingement* on protective clothing where flame resistance is not the primary form of protection offered by that clothing.

3.19 *shrinkage, n*—a decrease in one or more dimensions of an object or material.

3.19.1 *Discussion*—In evaluating the effects of flame impingement, these changes in dimension are caused by heat from the flame source.

4. Summary of Test Method

4.1 A conditioned specimen of a protective clothing material is folded in half and placed in a sample holder with the folded edge suspended over a gas flame.

4.2 The specimen is exposed to the flame for a 3-s interval.

4.2.1 If the material ignites during this exposure, the after-flame time, afterglow time, and burn distance of the specimen are measured and reported. Any observations of burning behavior are also reported. The test is then terminated.

4.3 If the material does not ignite after the first exposure, the same specimen is exposed to the flame for a 12-s interval. The after-flame time, afterglow time, and burn distance of the specimen are measured and reported. Any observations of burning behavior are also reported.

4.4 Alternative procedures are provided for conducting the 3-s or 12-s exposures only.

5. Significance and Use

5.1 This test method is intended to determine the ignition resistance and burning characteristics of materials used in protective clothing, where flame resistance is not the primary form of protection designated.

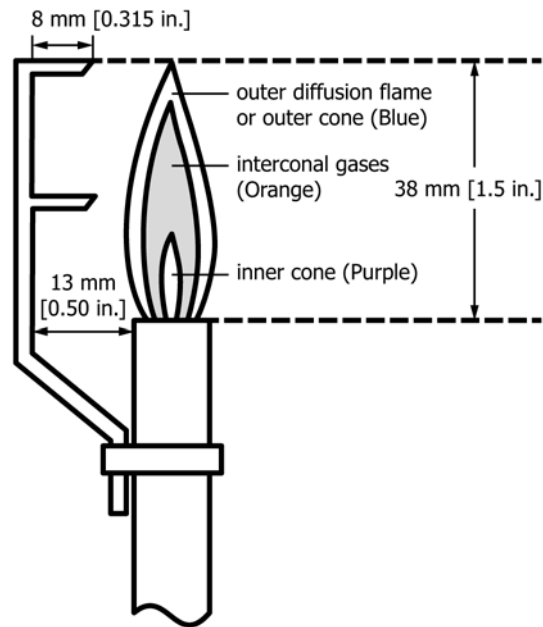

FIG. 1 Flame Height Adjustment

5.1.1 Flame resistance is a distinctive property of clothing items designated for isolating parts of the body from anticipated flame hazards. It is possible that protective clothing designated for isolation from other hazards, such as those for chemical or biological protection, neither have flame resistance nor isolate the wearer from flame hazards. This test method can be used to evaluate the effects of flame impingement on protective clothing where flame resistance is not the primary objective of protection.

5.1.2 When flame resistance is the primary protection offered by the protective clothing, alternative test methods can be used. A test method that is useful for evaluating flame resistance of textiles is Test Method D6413. Classification Index D4723 contains descriptions and guidance on other flammability test methods for textiles.

5.1.3 This test method is useful to determine the ignition resistance and burning characteristics of materials used in protective clothing not designated for flame resistance when the outer material surface is exposed to the flame. As such, it is particularly suited to protective clothing materials that are composed of different layers such as coated fabrics, laminates, or multilayer clothing systems.

5.2 Alternative procedures for conducting either a 3-s or 12-s exposure are provided where one or the other flame application exposure times are applied. The choice of either the shorter or longer single exposure time is provided to permit an assessment of the effects for flame impingement on materials under short term and long term flame exposure conditions.

5.3 Correlation of data from this test method with the ignition resistance and burning characteristics of protective clothing (not designated for flame resistance) under actual use conditions is not implied.

6. Apparatus

6.1 Use the test apparatus as specified in Test Method D6413, including the test cabinet and accessories, burner, gas regulator valve system, gas mixture, test specimen holder, specimen holder clamps, laboratory hood, stop watch, measuring scale, and flame impingement timer.

NOTE 1—Shortening the length of the test specimen holder is one way the cabinet does not need to be adjusted for this test method to provide the correct location of the folded edge specimen above the flame.

7. Hazards

7.1 Normal precautions applicable to pressurized flammable gases, open flames, hot flames, hot surfaces, burning fabrics and combustion, off gases, and solid residue shall be employed.

7.2 Conduct the tests in a hood to contain the gases evolved during testing and for exhaust of the gases after each test.

8. Preparation of Apparatus

8.1 Adjust gas pressure to 17.2 ± 1.7 kPa [2.50 ± 0.25 lbf/in.²] and ignite pilot flame. Adjust the pilot flame to a height of approximately 3 mm [0.12 in.] when measured from its lowest point. Be sure that the tip does not alter shape of the test flame during either the 3 s or the 12 s exposure time.

8.1.1 Adjust the burner flame using the needle valve in the base of the burner to achieve a flame height of 38 mm [1.50 in.]. This height is achieved by fully closing the air opening on the burner tube base and fully opening the solenoid valve.

NOTE 2—The use of tape is one way to close off the air openings on the burner.

8.1.1.1 The 38-mm [1 1/2 in.] flame height is obtained by adjusting the flame level with the top of the metal prong. (See

Fig. 1). It is important that the flame height be adjusted with the tip of the flame level with the tip of the metal prong. The tip of the methane flame is blue, transparent, and difficult to see; it is more easily seen if there is no light on the flame, for example in a darkened room. An easy way to accomplish this is by turning off all nearby lights.

8.1.2 Position the burner so that the middle of the lower edge to the specimen holder is centered 19 mm [0.75 in.] above the burner.

NOTE 3—It is often necessary to turn off nearby lights to make sure of the accuracy of intersect of the midpoint of the flame with the mounting clamp.

8.2 Adjust the timer to provide a 3 ± 0.2 -s or 12 ± 0.2 -s flame to the specimen, depending on the test exposure chosen.

8.2.1 Use an accurate laboratory hand-held timer or a stopwatch to verify the flame impingement time by measuring the interval between the opening and closing of the solenoid.

9. Test Specimens

9.1 Prepare ten test specimens 75 mm in width by 400 mm in length [3 in. by 16 in.]. If the material is anisotropic, cut five specimens along each axis.

10. Conditioning

10.1 Unless otherwise specified, condition all samples to be tested at a relative humidity of 45 to 70 % and a temperature of 20 to 25°C [67 to 77°F] for at least 24 h prior to testing.

10.2 Mount and expose each specimen to the flame within 4 min of removal from the conditioning area or storage.

11. Procedure

11.1 Place the apparatus in a hood with the ventilating fan turned off at the time of the test.

11.2 Fold specimens in half across the width with the normal outside surface of the material facing out. Produce the fold with the metal rod at the bend inside the material. Avoid making permanent creases at the folded edge.

11.3 Place the material specimen in its holder. The folded edge of the specimen shall protrude approximately 6 mm [$\frac{1}{4}$ in.] below the lower horizontal end of the metal specimen clamp. Materials with different thicknesses will result in slightly different protrusion lengths from the end of the clamp. Remove the metal rod after the material is clamped in the holder.

11.4 With the pilot light still on, shut off the gas to the burner with the stopcock or solenoid valve. Place the specimen holder over the specimen holder bar, held in position by the specimen holder support. Adjust the specimen holder bar to position the folded edge of the specimen 19 mm [$\frac{3}{4}$ in.] above the top of the burner. Shut the cabinet door and keep it closed until all combustion of the specimen has ceased.

11.5 Simultaneously start the timer and open the stopcock to the regulated gas source. Apply the tip of the flame to the end of the folded edge of the specimen for 3 ± 0.1 s. At the end of this exposure, turn off the stopcock to the regulated gas source.

11.6 Observe and note whether or not the specimen ignites (a specimen is considered to have ignited when it continues to burn for more than 2.0 ± 0.1 s after turning off the gas supply to the flame). If the specimen ignites during the 3-s flame exposure:

11.6.1 Continue the test and stop the timer when no visible flame is present on the material specimen. Subtract 3 s from the measured time. Record this time as after-flame time. Also record the afterglow time, if observed.

11.6.2 Note the apparent cause of extinguishment such as shrinkage, destruction, or dripping.

11.6.3 After specimen burning ceases, turn on the hood ventilation fan to clear the hood of combustion gases.

11.6.4 Measure the burn distance on the specimen after the 3-s flame exposure. Record the burn distance to the nearest 1 mm [$\frac{1}{16}$ in.]. Wiping the material specimen with a damp cloth or paper towel helps to more clearly determine the burn distance.

11.6.5 Do not continue any testing on the specimen.

11.7 If the specimen does not ignite after the 3-s flame exposure:

11.7.1 Restart the stopwatch from zero and reapply the flame to the folded edge of the same specimen at the same location used in the 3-s exposure for an additional 12 ± 0.1 s. The time interval between flame exposures shall be 4 ± 1 s.

11.7.2 Allow the stopwatch to keep running. Observe and note whether or not the specimen ignites (a specimen is considered to have ignited when it continues to burn for more than 2.0 ± 0.1 s after turning off the gas supply to the flame). Stop the timer when no visible flame is present on the material specimen. Subtract 12 s from the measured time. Record this time as after-flame time. Also record the afterglow time, if observed.

11.7.3 Note the apparent cause of extinguishment such as shrinkage, destruction, or dripping.

11.7.4 After specimen burning ceases, turn on the hood ventilating fan to clear the hood of combustion gases.

11.7.5 Measure the burn distance on the specimen after the 12-s flame exposure. Record the burn distance to the nearest 1 mm [$\frac{1}{16}$ in.]. Wiping the material specimen with a damp cloth or paper towel helps to more clearly determine the burn distance.

11.7.6 Determine whether the specimen has melted as the result of the exposure if the specimen has ignited. Examine the outer surface of the folded specimen for evidence of melting. Also, examine the interior of the specimen for evidence of melting by unfolding the specimen. Report if the interior of the specimen has melted causing the two sides of the specimen to stick together.

11.8 Alternative Test Procedure—As alternative to the procedures provided in 11.1 – 11.7.5, conduct the test using either a 3-s or a 12-s flame exposure only.

11.8.1 For a 3-s exposure, follow the steps in 11.1 – 11.6, omitting the 12-s exposure steps in 11.7.

11.8.2 For a 12-s exposure, follow the steps in 11.1 – 11.4. Skip the 3-s exposure steps in 11.5 and 11.6 and begin with the 12-s exposure described in 11.7.

12. Test Results

12.1 *Flammability*—Note flammability as the number of specimens igniting during the 3-s flame exposure period, the number of specimens igniting during the subsequent 12-s flame exposure period, and the number of specimens not igniting at all.

12.2 *After-flame Time*—Measure after-flame time as the time, reported in seconds, from the moment that the operator removes the flame from the specimen until no visible flame is present on the material specimen.

12.3 *Afterglow Time*—Measure the afterglow as the time, reported in seconds, that the specimen glows. If present, afterglow is observable either immediately after the removal of the flame from the specimen or after sample burning has ceased (after-flame time).

12.4 *Burn Distance*—Measure the burn distance in millimetres (inches) from the bottom edge of the material specimen to the farthest vertical point on the folded specimen, when pressed flat, that is burned in the test following the respective flame exposure period. This includes all areas of the specimen which are partially burned, charred, embrittled, or melted, but not areas sooted, stained, distorted, or discolored. Do not include damage due to mechanical delamination or splitting of the specimen in the measurement of burn distance unless the delaminated or split area includes damage due to combustion.

12.5 *Burning Behavior*—Note the burning behavior of the specimen for the samples that ignite. This shall include observations of specimen shrinkage, destruction, melting, or dripping.

12.5.1 Some materials shrink away from the flame without ignition and it is possible that subsequent reexposure of the same specimen does not produce direct contact with the flame source. As a consequence, it is possible that a relatively short after-flame time or small burn distances is measured. Record this phenomenon as a characteristic of the material specimen, when observed.

13. Report

13.1 Report that the specimens were tested as described in Test Method F1358. Identify the protective clothing material tested and note the manufacturer or source of the material and its application. Provide a description of the material noting which surface was exposed to the flame.

13.2 For each specimen tested, report the following measurements and observations.

13.2.1 *Flammability*:

13.2.1.1 Ignition noted during 3-s flame exposure period,

13.2.1.2 Ignition noted during 12-s flame exposure period, or

13.2.1.3 Did not ignite in either flame exposure period.

13.2.2 After-flame time, afterglow time, and burn distance if specimen ignites during 3-s flame exposure period.

13.2.3 After-flame time, afterglow time, and burn distance if specimen ignites during 12-s flame exposure period.

13.2.4 Specific observations of burning behavior including specimen shrinkage, destruction, or dripping if the specimen ignites.

13.2.5 An observation if the specimen has melted and the side of the specimen on which the melting is observed if the specimen ignites.

13.3 For each material tested, report the following:

13.3.1 Number of test specimens igniting during the first 3-s flame exposure period,

13.3.2 Number of test specimens igniting during subsequent 12-s flame exposure period,

13.3.3 Number of test specimens not igniting in either flame exposure period, and

13.3.4 Average burning characteristics following 3-s exposure as follows:

13.3.4.1 Average after-flame and afterglow times, and

13.3.4.2 Average burn distance.

13.3.5 Average burning characteristics following 12-s exposure:

13.3.5.1 Average after-flame and afterglow times, and

13.3.5.2 Average burn distance.

13.3.6 Observations of material burning behavior including specimen shrinkage, destruction, or dripping if the specimen ignites.

13.3.7 Any observation of melting for the exterior or interior of any specimen if the specimen ignites.

13.4 If the alternative test procedures for this test method are used, indicate in the report that the alternative test procedure was used with a 3-s or 12-s exposure only. Report required test information from 13.2 and 13.3 for the 3-s or 12-s exposure only.

14. Precision and Bias

14.1 *Precision*:

14.1.1 *Single Laboratory Study*—Three chemical protective clothing fabrics were tested in one laboratory, using one operator to determine if the specimen ignited during the first 3-s flame exposure period, if the specimens ignited during the subsequent 12-s flame exposure period, afterflame time, and burn distance measured on each specimen by the procedure. Ten specimens were taken from each fabric sample, five in the lengthwise (machine) direction and five in the widthwise (cross-machine) direction. This single-laboratory set is analyzed and used in writing a temporary precision statement, pending a full interlaboratory study. Until the full study is completed, users of the test method are advised to exercise conventional statistical caution in making any comparisons of the test results. **Table 1** provides a summary of test data for the materials tested, while **Table 2** and **Table 3** provide a within laboratory (repeatability) critical differences for afterflame a time and burn distance. (The critical difference is the observed difference between two test results, which should be considered significant at the specified probability level, as defined in Terminology **D123**).

14.1.2 *Specimen Ignition*—Since observations are used to determine whether specimens ignited in either the 3-s or 12-s flame exposure periods, the information for the three materials is reported in **Table 1**.

TABLE 1 Single Laboratory Study Data

Material	Direction	No. Specimens After 3-s Exposure	Igniting After 12-s Exposure	Specimens Not Igniting in 3-s and 12-s Exposures	Average Afterflame (s)	Average Burn Distance (mm)
A	Lengthwise	0	0	5	0	1.0
	Widthwise	0	0	5	0	1.3
B	Lengthwise	0	0	5	0	16.4
	Widthwise	0	0	5	0	15.2
C	Lengthwise	0	5	0	5.8	12.6
	Widthwise	0	5	0	9.8	18.8

TABLE 3 Repeatability or Within-Laboratory Critical Differences

Burn Distance (mm) (95 % Probability Level)		
N ^A	SE ^B	CD ^C
1	0.095	0.266
3	0.054	0.154
5	0.042	0.118
7	0.036	0.100

^A N = Number of determinations per average

^B SE = Standard Error for N determinations

^C CD = 2.8 SE

TABLE 2 Repeatability or Within-Laboratory Critical Differences

Afterflame Time (s) (95 % Probability Level)		
N ^A	SE ^B	CD ^C
1	0.078	0.218
3	0.045	0.126
5	0.034	0.095
7	0.029	0.081

^A N = Number of determinations per average

^B SE = Standard Error for N determinations

^C CD = 2.8 SE

14.1.3 *Afterflame Time*—Variances for the lengthwise and widthwise specimens are similar, ranging in value from 0.38 to 0.49, with an average value of 0.43 s² (standard deviation = 0.078) as determined by analysis of variance. Critical differences, based on this value and a 95 % probability level, are either to lengthwise average comparisons, or to widthwise average comparisons, to determine significance.

14.1.4 *Burn Distance*—Variances for the lengthwise and widthwise specimens are similar, ranging in value from 0.12 to 0.32, with an average value of 0.21 mm² (standard deviation = 0.095) as determined by analysis of variance. Critical differences, based on this value and a 95 % probability level, are either to lengthwise average comparisons, or to widthwise average comparisons, to determine significance.

14.2 *Bias*—There is no accepted referee method for determining the true value of ignition resistance and burning behavior of protective clothing materials not designated for flame resistance. The value is defined only in terms of a test method. This test method has no known bias.

15. Keywords

15.1 burning behavior; flame impingement; flame resistance; ignition; protective clothing

ASTM International takes no position respecting the validity of any patent rights asserted in connection with any item mentioned in this standard. Users of this standard are expressly advised that determination of the validity of any such patent rights, and the risk of infringement of such rights, are entirely their own responsibility.

This standard is subject to revision at any time by the responsible technical committee and must be reviewed every five years and if not revised, either reapproved or withdrawn. Your comments are invited either for revision of this standard or for additional standards and should be addressed to ASTM International Headquarters. Your comments will receive careful consideration at a meeting of the responsible technical committee, which you may attend. If you feel that your comments have not received a fair hearing you should make your views known to the ASTM Committee on Standards, at the address shown below.

This standard is copyrighted by ASTM International, 100 Barr Harbor Drive, PO Box C700, West Conshohocken, PA 19428-2959, United States. Individual reprints (single or multiple copies) of this standard may be obtained by contacting ASTM at the above address or at 610-832-9585 (phone), 610-832-9555 (fax), or service@astm.org (e-mail); or through the ASTM website (www.astm.org). Permission rights to photocopy the standard may also be secured from the Copyright Clearance Center, 222 Rosewood Drive, Danvers, MA 01923, Tel: (978) 646-2600; http://www.copyright.com/