



Standard Practice for Determination of the Effect of Hard Creasing Paper on Images Produced by Business Imaging Systems¹

This standard is issued under the fixed designation F1351; the number immediately following the designation indicates the year of original adoption or, in the case of revision, the year of last revision. A number in parentheses indicates the year of last reapproval. A superscript epsilon (ϵ) indicates an editorial change since the last revision or reapproval.

1. Scope

1.1 This practice describes a procedure for hard creasing paper in a uniform and reproducible manner.

1.2 The crease is positioned across the image and the amount of image degradation is determined.

1.3 The effect of creasing on the paper surface can also be determined.

1.4 The values stated in inch-pound units are to be regarded as standard. The values given in parentheses are mathematical conversions to SI units that are provided for information only and are not considered standard.

1.5 *This standard does not purport to address all of the safety concerns, if any, associated with its use. It is the responsibility of the user of this standard to establish appropriate safety and health practices and determine the applicability of regulatory limitations prior to use.*

2. Referenced Documents

2.1 *ASTM Standards:*²

D528 Test Method for Machine Direction of Paper and Paperboard (Withdrawn 2010)³

D685 Practice for Conditioning Paper and Paper Products for Testing

D5039 Test Methods for Identification of Wire Side of Paper (Withdrawn 2009)³

3. Terminology

3.1 *Definitions:*

¹ This practice is under the jurisdiction of ASTM Committee F05 on Business Imaging Products and is the direct responsibility of Subcommittee F05.04 on Electrostatic Imaging Products.

Current edition approved April 1, 2013. Published April 2013. Originally approved in 1991. Last previous edition approved in 2008 as F1351 – 96 (2008). DOI: 10.1520/F1351-96R13.

² For referenced ASTM standards, visit the ASTM website, www.astm.org, or contact ASTM Customer Service at service@astm.org. For *Annual Book of ASTM Standards* volume information, refer to the standard's Document Summary page on the ASTM website.

³ The last approved version of this historical standard is referenced on www.astm.org.

3.1.1 *hard-crease*—paper folded 180° (back to back, face to face, long grain, short grain) with a uniform force applied to the fold.

4. Summary of Practice

4.1 This practice describes a mechanical device that makes it possible to uniformly hard-crease samples of paper so that comparative tests may be performed on the samples. Comparison may be made with a control sample.

4.2 This practice also provides a means of locating the crease over a line of copy.

4.3 The image may be produced by any of the several business imaging systems including copiers, printers, typewriters, etc.

5. Significance and Use

5.1 As a comparative test, this practice can be used to determine the damage caused by creasing paper, that is, damage to paper, coatings or images affixed to the paper and the loss of image quality and legibility that can result from creasing.

6. Interference

6.1 The accuracy with which the crease is located on the paper, that is, over an image area, is dependent on operator skill and the consistency with which the samples are prepared.

6.2 Sample to sample variations in caliper, moisture content, grain direction, etc., influence the damage caused by creasing.

6.3 Similarly, using imaged paper samples, the imaging material, the method of application, aging, as well as the substrate, may influence crease damage and the subsequent loss of image legibility.

6.4 This practice is useful for papers of basis weights normally used for office correspondence. Heavy weight or stiff papers may need special handling at the discretion of the person conducting the test.

7. Apparatus

7.1 *Fixture*, hard-crease, see Fig. 1.

7.2 *Paper Cutting Board*.

- 1 BASE – 3/8" × 12" × 18" DIE PLATE OR EQUIVALENT.
- 1 ROLLER GUIDE BAR – 1" × 1" × 13" BAR STOCK.
- 1 SAMPLE HOLD-DOWN – 1" × 1" × 10" BAR STOCK.
- 1 2 KILO BALANCE WEIGHT – 2 1/2" × 2 3/4" BRASS.

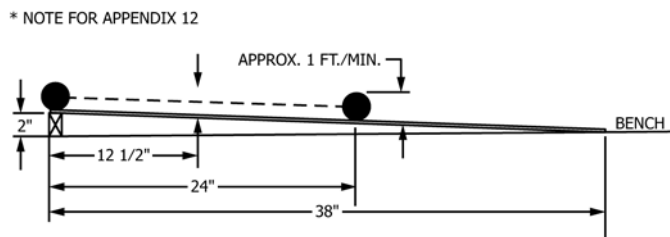
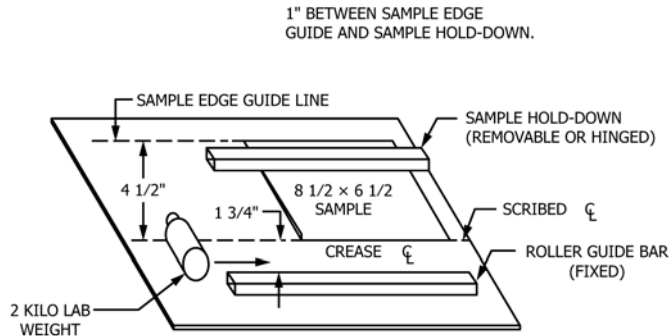

FIG. 1 Hard-Crease Fixture

8. Procedure

8.1 Because the moisture content of paper effects the creasability of paper, conduct the test in a room conditioned according to Practice D685. If such a room is not available, conduct the tests in a room with a stable temperature and humidity.

8.2 Test specimens are any imaged paper produced by a business imaging system such as copiers, printers, typewriters, etc. Position the image so that it will be creased in the manner that will simulate end use.

8.3 Cut four sheets from each sample of paper to be tested, all with dimensions 8½ by 8½ in. (216 by 216 mm) in the

machine direction and then cut four in the cross direction. Identify machine direction (duplicate sets of each grain direction). Small images require cutting so as to locate the image on crease.

8.4 Determine and identify the “front,” “back,” imaged, unimaged, wire, or felt side and grain direction of control and the sample sheets using Test Methods D528 and D5039.

8.5 Condition the sheets for a minimum of 24 h in the test room.

8.6 Conduct duplicate tests in each direction and on each side of the sheet.

8.7 Bend, but do not fold, the test piece so that the crease will be parallel to the machine direction and the image will face inward.

8.8 With moderate speed (approximately 1 ft/s) (3 m/s) roll the 2 kg weight so that it creases the paper. See Appendix. Place the image so as to be within the crease.

8.9 Repeat test with duplicate test piece.

8.10 Bend sample as in 8.7 but with the image outward and repeat 8.8 and 8.9.

8.11 Repeat 8.7 through 8.10 with the test piece positioned so that the crease is perpendicular to the machine direction.

9. Interpretation of Results

9.1 Compare samples and control sheets that have been hard-creased front to front, back to back, in the machine direction and the cross direction.

9.2 Comparisons can be made by visual observation, reporting the damage done by hard-creasing to coatings, images or substrate. A hand lens of approximately 10× may be used to aid in the examination. It may be appropriate to rub the image to determine if it has been loosened. Bar code, OCR, or MICR readers can be used in special cases.

10. Report

10.1 Report the following information:

10.1.1 The nature of the image or paper degradation and a ranking order established when two or more samples are tested.

11. Keywords

11.1 image permanence-creasing; paper damage-creasing

APPENDIX

(Nonmandatory Information)

X1.

X1.1 The speed of a brass roller of approximately 1 ft/s (0.30 m/s) can be obtained using an inclined plane in the following manner:

X1.1.1 A 2 kg brass weight size 2½ in. (6.35 mm) diameter by 2¾ in. (6.99 mm) height.

X1.1.2 An inclined plane such as a piece of aluminum or steel plate with a pitch of 2 in. (5.08 mm) per 38 in. (96.52 mm).

X1.2 From a standing start, the weight will pass from marks 12½ to 24¾ in. (31.8 to 61.9 mm) from the starting point (approximately 1 ft (0.30 m)) in approximately 1 s.

X1.3 Thus if the bent sample is placed on the inclined plane approximately 12½ in. (31.8 mm) from the starting point and the weight is allowed to roll freely, it will crease the specimen at a speed of approximately 1 ft/s (0.30 m/s) as recommended in 8.7.

ASTM International takes no position respecting the validity of any patent rights asserted in connection with any item mentioned in this standard. Users of this standard are expressly advised that determination of the validity of any such patent rights, and the risk of infringement of such rights, are entirely their own responsibility.

This standard is subject to revision at any time by the responsible technical committee and must be reviewed every five years and if not revised, either reapproved or withdrawn. Your comments are invited either for revision of this standard or for additional standards and should be addressed to ASTM International Headquarters. Your comments will receive careful consideration at a meeting of the responsible technical committee, which you may attend. If you feel that your comments have not received a fair hearing you should make your views known to the ASTM Committee on Standards, at the address shown below.

This standard is copyrighted by ASTM International, 100 Barr Harbor Drive, PO Box C700, West Conshohocken, PA 19428-2959, United States. Individual reprints (single or multiple copies) of this standard may be obtained by contacting ASTM at the above address or at 610-832-9585 (phone), 610-832-9555 (fax), or service@astm.org (e-mail); or through the ASTM website (www.astm.org). Permission rights to photocopy the standard may also be secured from the Copyright Clearance Center, 222 Rosewood Drive, Danvers, MA 01923, Tel: (978) 646-2600; http://www.copyright.com/