



# Standard Specification for Large-Diameter Fabricated Carbon Steel Flanges<sup>1</sup>

This standard is issued under the fixed designation F1311; the number immediately following the designation indicates the year of original adoption or, in the case of revision, the year of last revision. A number in parentheses indicates the year of last reapproval. A superscript epsilon ( $\epsilon$ ) indicates an editorial change since the last revision or reapproval.

## 1. Scope

1.1 This specification provides design and construction criteria for large diameter flanges sizes 14 to 144 NPS, for use in high temperature (1000°F), low pressure service (25 psig), such as internal combustion engine exhaust and forced ventilation systems.

1.2 Values stated in inch-pound units are to be regarded as the standard.

## 2. Referenced Documents

### 2.1 ASTM Standards:<sup>2</sup>

[A36/A36M Specification for Carbon Structural Steel](#)  
[F1155 Practice for Selection and Application of Piping System Materials](#)

### 2.2 American Water Works Association:<sup>3</sup>

[AWWA C207 Steel Pipe Flanges for Waterwork Service 4 in. through 144 in.](#)

### 2.3 Other Documents:

[American Bureau of Shipping Rules for Building and Classing of Steel Vessels, ABS Grade A<sup>4</sup>](#)  
[American Welding Society Publication, AWS D 1.1 Structural Welding Code<sup>5</sup>](#)  
[Code of Federal Regulations Title 46, Subpart 56.30—10 \(b\) \(5\)<sup>6</sup>](#)

<sup>1</sup> This specification is under the jurisdiction of ASTM Committee F25 on Ships and Marine Technology and is the direct responsibility of Subcommittee F25.11 on Machinery and Piping Systems.

Current edition approved May 1, 2012. Published May 2012. Originally approved in 1990. Last previous edition approved in 2006 as F1311 – 90 (2006). DOI: 10.1520/F1311-90R12.

<sup>2</sup> For referenced ASTM standards, visit the ASTM website, [www.astm.org](http://www.astm.org), or contact ASTM Customer Service at [service@astm.org](mailto:service@astm.org). For *Annual Book of ASTM Standards* volume information, refer to the standard's Document Summary page on the ASTM website.

<sup>3</sup> Available from American Water Works Association (AWWA), 6666 W. Quincy Ave., Denver, CO 80235, <http://www.awwa.org>.

<sup>4</sup> Available from American Bureau of Shipping (ABS), ABS Plaza, 16855 Northchase Dr., Houston, TX 77060, <http://www.eagle.org>.

<sup>5</sup> Available from American Welding Society (AWS), 550 NW LeJeune Rd., Miami, FL 33126, <http://www.aws.org>.

<sup>6</sup> Available from Standardization Documents Order Desk, DODSSP, Bldg. 4, Section D, 700 Robbins Ave., Philadelphia, PA 19111-5098, <http://dodssp.daps.dla.mil>.

[ASME Boiler and Pressure Vessel Code, Section IX, Welding Qualifications<sup>7</sup>](#)

## 3. Classification

3.1 *Type I*—Plate flanges, for sizes 14 in. inside diameter up to and including 144 in. inside diameter (see [Fig. 1](#)).

3.2 *Type II*—Rolled angle flanges, for sizes 14 in. up to and including 108 in. inside diameter (see [Fig. 1](#)).

## 4. Ordering Information

4.1 Flanges ordered under this specification shall include the following:

- 4.1.1 . ASTM designation, title, number, and date of this specification,
- 4.1.2 Type and material,
- 4.1.3 Nominal pipe size,
- 4.1.4 Quantity, and
- 4.1.5 Inspection of items shall be agreed upon between the purchaser and the supplier.

## 5. Dimensions and Tolerances

5.1 *Dimensions*—Dimensions shall be in accordance with [Table 1](#).

### 5.2 Tolerances:

5.2.1 Plus or minus ¼ in. on outside and inside diameters shall apply on flanges of 22 in. nominal pipe size and above. The tolerance for flanges for 20 in. nominal size and below shall be  $\pm 1/8$  in.

5.2.2 Plus or minus 1/16 in. on bolting circle.

## 6. Drilling

6.1 Number of holes, hole diameter, and bolt circle are identical for both Type I and Type II flanges.

6.2 Bolt holes shall be equally spaced on the bolt circle.

6.3 Bolt holes provide for 1/8 in. diameter clearance on bolts.

6.4 Drilling of flanges shall be in accordance with [Table 1](#).

<sup>7</sup> Available from American Society of Mechanical Engineers (ASME), ASME International Headquarters, Three Park Ave., New York, NY 10016-5990, <http://www.asme.org>.

Vessels, ABS Grade A, American Welding Society Publications D1.1, or ASME Code Section IX.

7.3 Flange faces shall be smooth and free of projections or indentations that would prevent effective gasket seals.

7.4 Flanges when completed shall have no distortion, roundness, or flatness exceeding a tolerance of  $\pm 1/8$  in.

7.5 The surface finish shall be a minimum of 500  $\mu\text{in.}$  to ensure proper sealing surface for the gasket.

7.6 The material to be used for this specification shall be in accordance with Specification **A36/A36M**, unless prolonged high temperatures will be required; in that case ABS Grade A steel shall be specified in Section 4. For further guidance for selection of materials, see Practice **F1155** and CFR 56.30-10(b)(5).

**8. Rejection and Rehearing**

8.1 Flanges that fail to conform to the requirements of this specification may be rejected. Rejection may be reported to the producer or the supplier promptly in writing. In case of dissatisfaction with the damaged items, the producer or the supplier may make claim for a rehearing.

**9. Certification**

9.1 When specified in the purchase order or the contract, the purchaser shall be furnished with certification that samples representing the flanges have been inspected to meet the requirements of this specification. When specified in the purchase order or contract, a report of the results shall be furnished.

**10. Packaging and Package Marking**

10.1 Flanges shall be marked on the edge of each flange showing the purchase order number, ASTM designation number, material and type, size, and name of manufacturer.

10.2 The flanges shall be packaged in a manner acceptable for shipment by common carrier.

**11. Keywords**

11.1 carbon steel; flanges; large-diameter flanges; low pressure service flanges; marine technology; ships

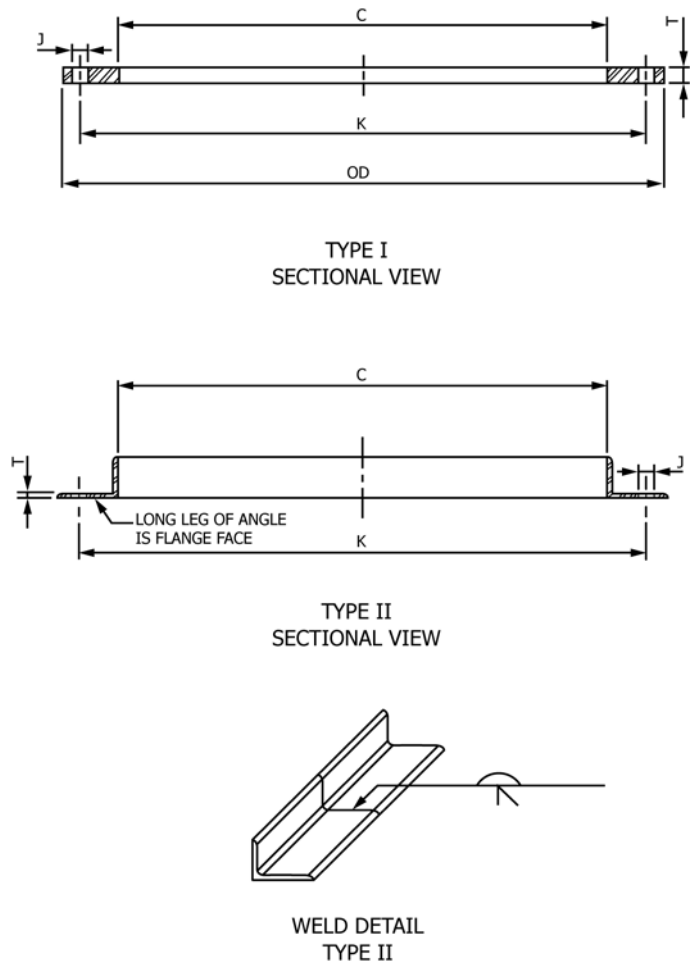

NOTE 1—1 in. = 25.4 mm

**FIG. 1 Flanges, Types I and II**

**7. Workmanship, Finish, and Appearance**

7.1 Flanges manufactured under this specification shall be free of all sharp edges, burrs, projections, weld spatter, and other defects that might be hazardous to personnel or equipment, or both.

7.2 Welding shall be in accordance with the American Bureau of Shipping Rules for Building and Classing of Steel

**TABLE 1 Dimensions 1 in. = 25.4 mm. 1 lb. = 0.45 kg.**

Nominal Pipe Size	Inside Diameter, C	Type I			Type II			Drilling		
		Outside Diameter, OD	Thickness, T	Weight in lb.	Angle Size	Thickness, T	Weight in lb.	No. of Holes	Diameter of Holes, J	Diameter of Circle, K
14	14 1/4	21	3/4	40	4 x 3	3/8	39	12	1 1/8	18 3/4
16	16 1/4	23 1/2	3/4	48	4 x 3	3/8	44	16	1 1/8	21 1/4
18	18 1/4	25	3/4	49	4 x 3	3/8	49	16	1 1/4	22 3/4
20	20 1/4	27 1/2	3/4	58	5 x 3	3/8	60	20	1 1/4	25
22	22 1/4	29 1/2	1.0	83	5 x 3	3/8	65	20	1 3/8	27 1/4
24	24 1/4	32	1.0	97	5 x 3	3/8	70	20	1 3/8	29 1/2
26	26 1/4	34 1/4	1.0	108	5 x 3	3/8	75	24	1 3/8	31 3/4
28	28 1/4	36 1/2	1.0	119	5 x 3	3/8	81	28	1 3/8	34
30	30 1/4	38 3/4	1.0	131	5 x 3	3/8	86	28	1 3/8	36
32	32 1/4	41 3/4	1 1/8	176	6 x 4	1/2	116	28	1 5/8	38 1/2
34	34 1/4	43 3/4	1 1/8	186	6 x 4	1/2	122	32	1 5/8	40 1/2
36	36 5/16	46	1 1/8	200	6 x 4	1/2	170	32	1 5/8	42 3/4
38	38 5/16	48 3/4	1 1/8	227	6 x 4	1/2	178	32	1 5/8	45 1/4
40	40 5/16	50 3/4	1 1/8	238	6 x 4	1/2	187	36	1 5/8	47 1/4
42	42 5/16	53	1 1/4	283	6 x 4	1/2	195	36	1 5/8	49 1/2
44	44 5/16	55 1/4	1 1/4	303	6 x 4	1/2	203	40	1 5/8	51 3/4
46	46 5/16	57 1/4	1 1/4	315	6 x 4	1/2	212	40	1 5/8	53 3/4
48	48 5/16	59 1/4	1 1/2	392	6 x 4	1/2	220	44	1 5/8	56
50	50 3/8	61 3/4	1 1/2	426	6 x 4	1/2	229	44	1 7/8	58 1/4
52	52 3/8	64	1 1/2	452	6 x 4	1/2	237	44	1 7/8	60 1/4
54	54 3/8	66 1/4	1 1/2	478	7 x 4	1/2	276	44	1 7/8	62 3/4
56	56 3/8	68 1/2	1 1/2	505	7 x 4	1/2	285	48	1 7/8	64 3/4
58	58 3/8	70 3/4	1 1/2	533	7 x 4	1/2	295	48	1 7/8	67
60	60 3/8	73	1 1/2	562	7 x 4	1/2	305	52	1 7/8	69 1/4
66	66 3/8	80	1 1/2	666	7 x 4	1/2	330	52	1 7/8	76
72	72 3/8	86 1/2	1 1/2	750	8 x 4	1/2	400	60	1 7/8	82 1/2
78	78 1/2	93	1 3/4	970	8 x 4	1/2	430	64	2 1/8	89
84	84 1/2	99 3/4	1 3/4	1100	8 x 4	1/2	460	64	2 1/8	95 1/2
90	90 1/2	106 1/2	1 3/4	1230	8 x 4	1/2	490	68	2 3/8	102
96	96 1/2	113 1/4	1 3/4	1370	9 x 4	1/2	570	68	2 3/8	108 1/2
102	102 1/2	120	1 3/4	1520	9 x 4	1/2	605	72	2 5/8	114 1/2
108	108 1/2	126 3/4	1 3/4	1670	9 x 4	1/2	64	72	2 5/8	120 3/4
114	114 1/2	133 1/2	1 3/4	1830	...	...	...	76	2 7/8	126 7/8
120	120 1/2	140 1/4	1 3/4	2000	...	...	...	76	2 7/8	132 3/4
126	126 1/2	147	2.0	2500	...	...	...	80	3 1/8	139 1/4
132	132 1/2	157 3/4	2.0	2710	...	...	...	80	3 1/8	145 3/4
138	138 1/2	160 1/2	2.0	2930	...	...	...	84	3 3/8	152
144	144 1/2	167 1/4	2.0	3160	...	...	...	84	3 3/8	158 1/4

ASTM International takes no position respecting the validity of any patent rights asserted in connection with any item mentioned in this standard. Users of this standard are expressly advised that determination of the validity of any such patent rights, and the risk of infringement of such rights, are entirely their own responsibility.

This standard is subject to revision at any time by the responsible technical committee and must be reviewed every five years and if not revised, either reapproved or withdrawn. Your comments are invited either for revision of this standard or for additional standards and should be addressed to ASTM International Headquarters. Your comments will receive careful consideration at a meeting of the responsible technical committee, which you may attend. If you feel that your comments have not received a fair hearing you should make your views known to the ASTM Committee on Standards, at the address shown below.

This standard is copyrighted by ASTM International, 100 Barr Harbor Drive, PO Box C700, West Conshohocken, PA 19428-2959, United States. Individual reprints (single or multiple copies) of this standard may be obtained by contacting ASTM at the above address or at 610-832-9585 (phone), 610-832-9555 (fax), or service@astm.org (e-mail); or through the ASTM website (www.astm.org). Permission rights to photocopy the standard may also be secured from the Copyright Clearance Center, 222 Rosewood Drive, Danvers, MA 01923, Tel: (978) 646-2600; http://www.copyright.com/