



Standard Test Method for Evaluating Carpet Embedded Dirt Removal Effectiveness of Residential Central Vacuum Cleaning Systems¹

This standard is issued under the fixed designation F1284; the number immediately following the designation indicates the year of original adoption or, in the case of revision, the year of last revision. A number in parentheses indicates the year of last reapproval. A superscript epsilon (ϵ) indicates an editorial change since the last revision or reapproval.

1. Scope

1.1 This test method covers only a laboratory test for determining the relative carpet dirt removal effectiveness of residential central vacuum cleaning systems when tested under specified conditions.

1.2 This test method is applicable to residential central vacuum cleaning systems intended for cleaning carpets.

1.3 This test method applies only to embedded dirt removal from carpets, not the removal of surface litter and debris.

1.4 The values stated in inch-pound units are to be regarded as standard. The values given in parentheses are mathematical conversions to SI units that are provided for information only and are not considered standard.

1.5 *This standard does not purport to address all of the safety concerns, if any, associated with its use. It is the responsibility of the user of this standard to establish appropriate safety and health practices and determine the applicability of regulatory limitations prior to use.*

2. Referenced Documents

2.1 *ASTM Standards:*²

[D75 Practice for Sampling Aggregates](#)

[E11 Specification for Woven Wire Test Sieve Cloth and Test Sieves](#)

[E177 Practice for Use of the Terms Precision and Bias in ASTM Test Methods](#)

[E691 Practice for Conducting an Interlaboratory Study to Determine the Precision of a Test Method](#)

[F608 Test Method for Evaluation of Carpet Embedded Dirt Removal Effectiveness of Household/Commercial Vacuum Cleaners](#)

[F655 Specification for Test Carpets and Pads for Vacuum Cleaner Testing](#)

[F884 Test Method for Motor Life Evaluation of a Built-In \(Central Vacuum\) Vacuum Cleaner](#)

[F922 Test Method for Motor Life Evaluation of an Electric Motorized Nozzle](#)

[F1038 Test Method for Motor Life Evaluation of a Canister, Hand-held, Stick, and Utility Type Vacuum Cleaner Without a Driven Agitator](#)

[F1334 Test Method for Determining A-Weighted Sound Power Level of Vacuum Cleaners](#)

[F1409 Test Method for Straight Line Movement of Vacuum Cleaners While Cleaning Carpets](#)

3. Terminology

3.1 *Definitions of Terms Specific to This Standard:*

3.1.1 *cleaning ability, n*—the potential of a vacuum cleaner to remove dirt from a surface (sometimes referred to in the industry as *cleanability, dry*).

3.1.2 *model, n*—the designation of a group of vacuum cleaners having identical, mechanical and electrical construction with only cosmetic or nonfunctional differences.

3.1.3 *population, n*—the total of all units of a particular model vacuum cleaner being tested.

3.1.4 *sample, n*—a group of vacuum cleaners taken from a large collection of vacuum cleaners of one particular model, which serves to provide information that may be used as a basis for making a decision concerning the larger collection.

3.1.5 *test run, n*—the definitive procedure that produces a singular measured result.

3.1.6 *test unit, n*—a single vacuum cleaner of the model being tested.

4. Significance and Use

4.1 This test method provides a laboratory test for determining the relative carpet dirt removal effectiveness of residential central vacuum cleaning systems when tested under standard conditions and on representative types of carpets.

4.2 This laboratory test method may not give a representation of carpet embedded dirt cleaning effectiveness in the home.

¹ This test method is under the jurisdiction of ASTM Committee F11 on Vacuum Cleaners and is the direct responsibility of Subcommittee F11.21 on Cleanability.

Current edition approved April 1, 2016. Published April 2016. Originally approved in 1992. Last previous edition approved in 2009 as F1284 – 09. DOI: 10.1520/F1284-09R16.

² For referenced ASTM standards, visit the ASTM website, www.astm.org, or contact ASTM Customer Service at service@astm.org. For *Annual Book of ASTM Standards* volume information, refer to the standard's Document Summary page on the ASTM website.

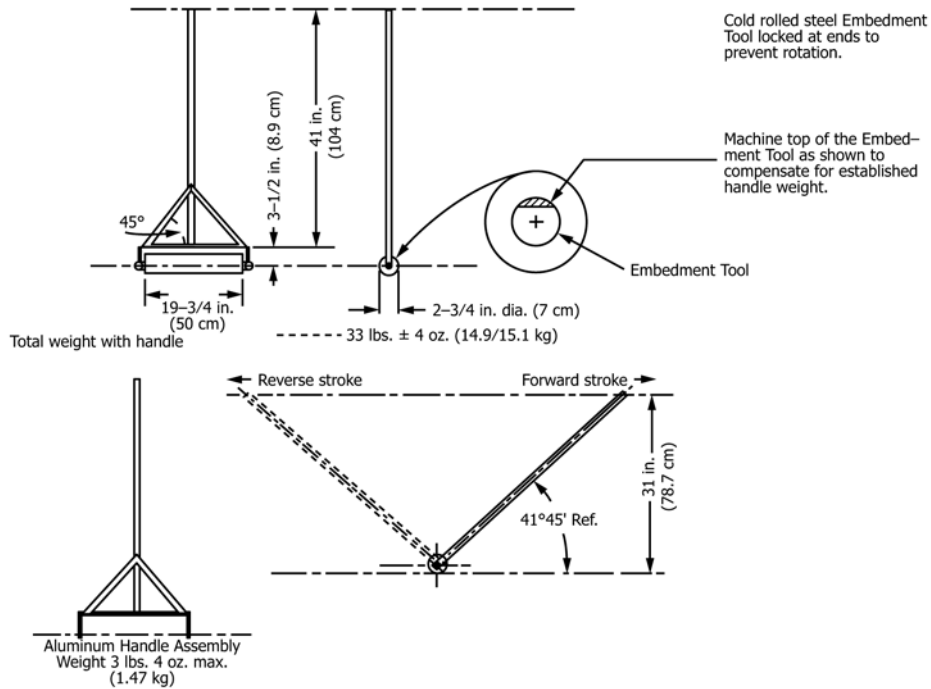

FIG. 1 Dirt Embedment Tool

4.3 In order to provide a uniform basis for measuring performance as described in 1.2, standardized test carpets and standardized test dirt are employed in this procedure.

4.4 The results reflect a non-loaded cleaning capability and may not be representative of cleaning capabilities under dirt loading conditions.

5. Apparatus

5.1 *Weighing Scale*³(for weighing carpets; see 9.1.1.5 and 9.4.5)—The scale must be accurate to 0.035 oz (1 g) and have a weighing capacity of at least 15 lb (6.82 kg).

5.2 *Weighing Scale*⁴(for weighing test dirt and non-disposable dirt receptacles; see 9.2.1.2 and 9.4.12)—The scale must be accurate to 0.0035 oz (0.10 g) and have a weighing capacity of at least 1.1 lb (500 g).

5.3 *Stopwatch* with a second hand, or other type of equipment capable of establishing the specified rate of movement and total cycle time.

5.4 *Voltmeter*, to measure input volts to the cleaning system to provide measurements accurate to within ±1 %.

5.5 *Voltage Regulator System*, to control the input voltage to the vacuum cleaner. The regulator shall be capable of maintaining the vacuum cleaner’s rated voltage ±1 % and rated frequency having a wave form that is essentially sinusoidal with 3 % max harmonic distortion for the duration of the test.

³ The OHAUS Models GT-8000, LB30-CO and 1119D, all available from OHAUS, Inc. Florham Park, NJ, or the equivalent, have been found suitable for this purpose. It is recommended that the scale read directly in grams.

⁴ The Mettler-Toledo Model PM 2000, available from Mettler-Toledo, Inc., Box 71, Highstown, NJ, 08520. The OHAUS Model-GT-8000 available from OHAUS, Inc., Florham Park, NJ, or equivalent, have been found suitable for this purpose. It is recommended that the seal read directly in grams.

5.6 *Dirt Embedment Tool*, with the roller locked (see Fig. 1).

5.7 *Dirt Dispenser*—Dispensing system that provides the operator with a method to distribute the test dirt uniformly on the carpet test area.

5.8 *Carpet Conditioning Equipment*, to support the test carpet during new carpet conditioning and the removal of residual dirt from the test carpet before each test run (Fig. 2).

5.9 *Rotating Agitator Conditioning Vacuum Cleaner/Equipment*, for conditioning new test carpets and removing residual dirt from the test carpet before each test run. This cannot be the unit being tested.

NOTE 1—Automated methods for spreading the test dirt, embedding the test dirt, and cleaning and reconditioning the test carpets are acceptable if they do not change the results of this test method.

5.10 *Temperature and Humidity Indicators*, to provide temperature measurements accurate to within ±1°F (±½ °C) and humidity measurements accurate to within ±2 % relative humidity.

5.11 *Supporting Surface*—A flat surface consisting of a piece of ¾-in. (19-mm) thick exterior-grade plywood with the “A” surface upward to support the test carpet and pad. If necessary, the four corners (only) of the test carpet and pad may be fastened to the supporting surface by any acceptable means.

5.12 *Rotating Agitator Reference Vacuum Cleaner*, one, for calibrating test carpets (see 9.2.4).

5.13 *Straight-Air Canister Reference Vacuum Cleaner*, one, for calibrating test carpets (see 9.2.4).

5.14 *Orifice Adapter Tube*—See Fig. 3.

6. Materials

6.1 *Standard Carpets*, conforming to Specification F655.

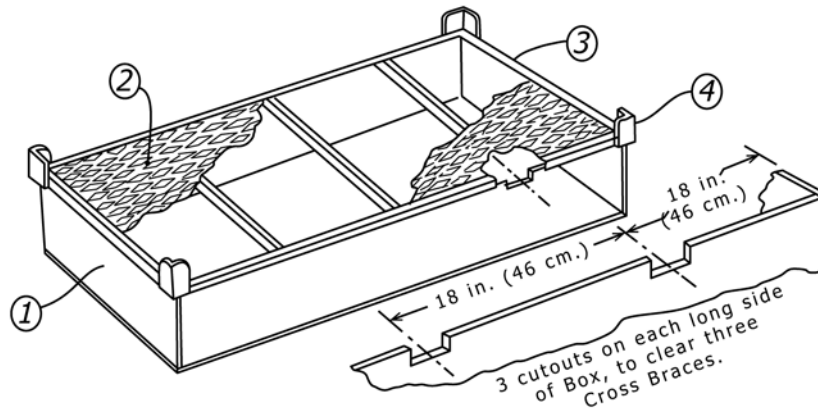

- ① -- Five Sided Box with open top.
 Outside Dimensions, Length -- 72 in. (183 cm.)
 Width -- 27 in. (69 cm.)
 Depth -- 12 in. (30.5 cm.)
 Material -- Plywood, 3/4 in. (1.9 cm.) thick.
 Optional -- Bottom of box may be sloped downward to center opening to simplify emptying of test dirt accumulation.
- ② -- Flattened Expanded Steel Top Panel, .070 in. (1.8 mm) thick, with "75% open" area, and with diamond shaped openings:--
 center-to-center, 2.1 in. (5.3 cm.) LWD
 center-to-center, 0.93 in. (2.4 cm.) SWD
 opening dimensions, 1.78 in. (4.5 cm.) LWD
 opening dimensions, 0.688 in. (1.7 cm.) SWD
 NOTE: Demcor Style "3/4 in.-#13" material has been found to be acceptable. (Designer's Metal Div'n. of Southern Electric, Inc.)

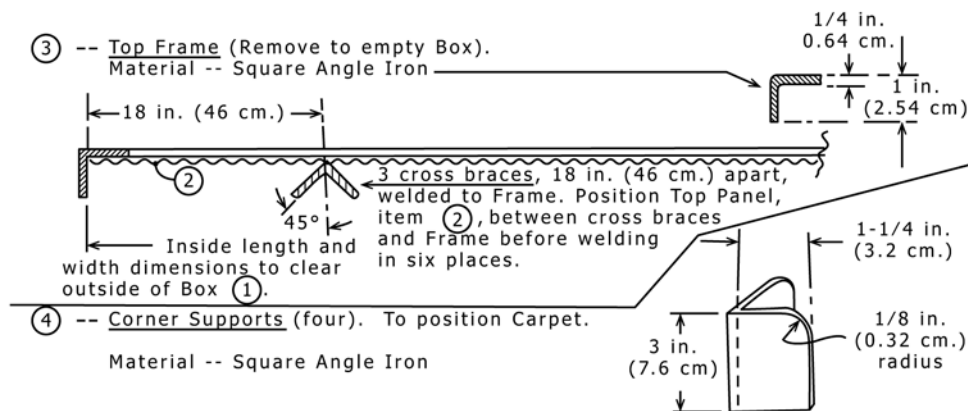

FIG. 2 Carpet Cleaning Rack

6.2 *Standard Carpet Padding*, conforming to Specification F655.

6.3 *Test Dirt* (see Annex A1).

6.3.1 *Silica Sand*—(see Annex A1).

6.3.2 *Talc*—see (Annex A1).

7. Sampling

7.1 A minimum of three units of the same model vacuum cleaner selected at random in accordance with good statistical practice shall constitute the population sample.

7.1.1 To determine the best estimate of the cleaning ability effectiveness for the population of the vacuum cleaner model being tested, the arithmetic mean of the cleaning ability rating

of the sample from the population shall be established by testing it to a 90 % confidence level within ± 5 % of the mean value of the cleaning ability rating.

7.1.2 Annex A3 provides a procedural example for determining the 90 % confidence level and when the sample size shall be increased.

NOTE 2—See Annex A3 for method of determining 90 % confidence level.

8. Conditioning

8.1 *Test Room*—Maintain the test room in which all conditioning and vacuum cleaner testing is done at $70 \pm 5^\circ\text{F}$ ($21 \pm 3^\circ\text{C}$) and 45 to 55 % relative humidity.

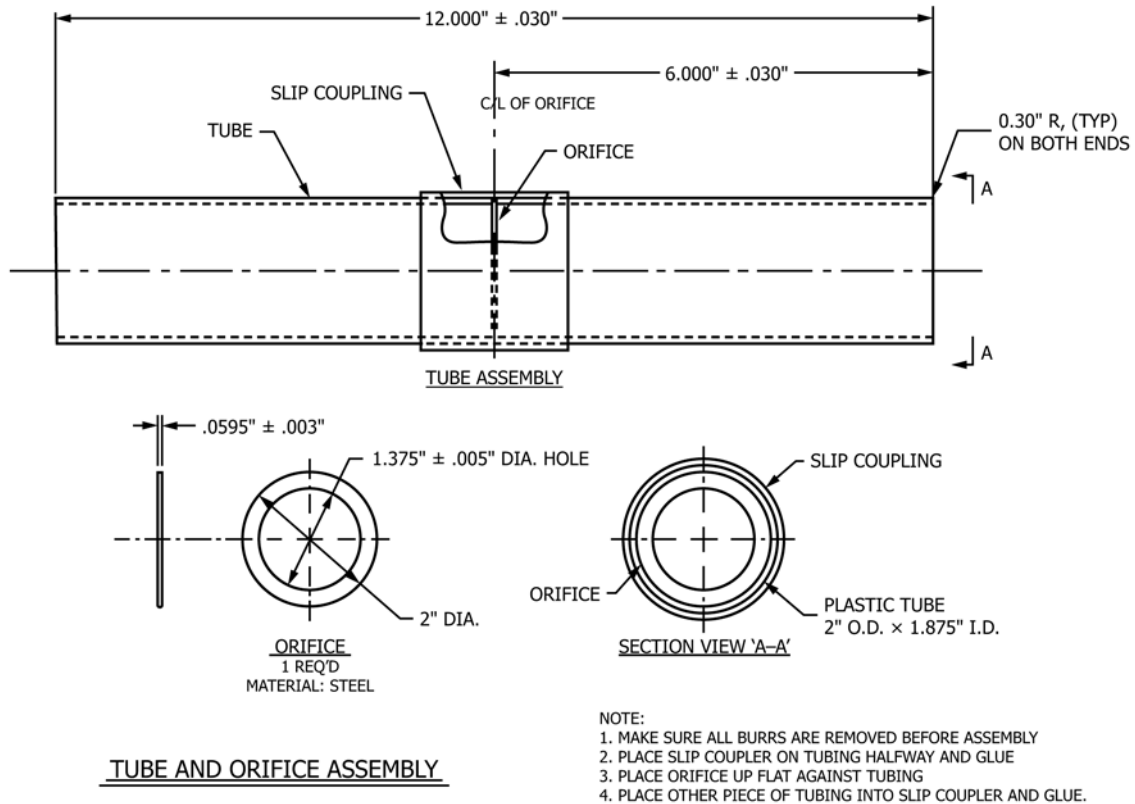

FIG. 3 Orifice Adapter Tube

8.2 All components involved in the test must remain and be exposed in the controlled environment for at least 16 h prior to the start of the test.

9. Procedure

9.1 *Test Carpet Preparation (see Fig. 4):*

9.1.1 *Preconditioning New Test Carpet Samples:*

9.1.1.1 New Test Carpets shall conform to Specification F655.

9.1.1.2 Cut a sample of each test carpet to a size of 27 by 72 in. (690 by 1830 mm) minimum. If the warp direction or “lay” of the carpet can be determined, it shall be in the 72 in. direction as indicated in Fig. 5. Carpets shall be bound on all sides.

9.1.1.3 Mark the test area on each carpet as indicated in Fig. 5.

9.1.1.4 *Precondition New Test Carpet Samples:*

(1) Precondition the entire area of the carpet by cleaning with the rotating agitator conditioning vacuum cleaner. Continue the operation until less than 0.07 oz (2 g) of carpet fiber is picked up in 5 min.

(2) Run ten carpet-embedded dirt removal effectiveness test runs in accordance with Sections 9.4.6 – 9.4.19.

NOTE 3—Recondition the new test carpet following each preconditioning test run. It is not necessary, however, to meet the requirements set forth in 9.1.2.1 with respect to the preconditioned weight.

9.1.1.5 Weigh and record the preconditioned weight of the carpet.

9.1.1.6 Run a test carpet calibration in accordance with Section 9.3.

9.1.2 *Reconditioning Used Test Carpet Samples:*

9.1.2.1 Initial Daily Reconditioned Weight: At the beginning of each day, it is necessary to remove any dirt that may have settled on the carpet surface and stabilize the moisture content of the carpet. Clean the carpet with a rotating agitator conditioning vacuum cleaner until its weight does not exceed the initial reconditioned weight from the previous day of testing by more than 0.07 oz (2 g) or less than 0.035 oz (1 g) is picked up by the conditioning vacuum cleaner using the procedure in 9.1.2.3.

9.1.2.2 Following each test run, it is necessary to remove the residual dirt and stabilize the moisture content of the carpet. Clean the carpet with a rotating agitator conditioning vacuum cleaner until its weight does not exceed the initial daily reconditioned weight requirement of 9.1.2.1 by more than 0.07 oz (2 g) or less than 0.035 oz (1 g) is picked up by the conditioning vacuum cleaner using the following procedure.

9.1.2.3 *Procedure:*

(1) Place the carpet on the carpet cleaning rack (Fig. 2) with the pile side down. Run the rotating agitator conditioning vacuum cleaner over the carpet for 2 min concentrating on the test area at 1.8 ft/s (0.55 m/s); then run the rotating agitator conditioning vacuum cleaner thoroughly over the entire carpet area at least one time.

(2) Place the carpet (pile side up) on the pad, on the plywood supporting surface, and clean it with the rotating

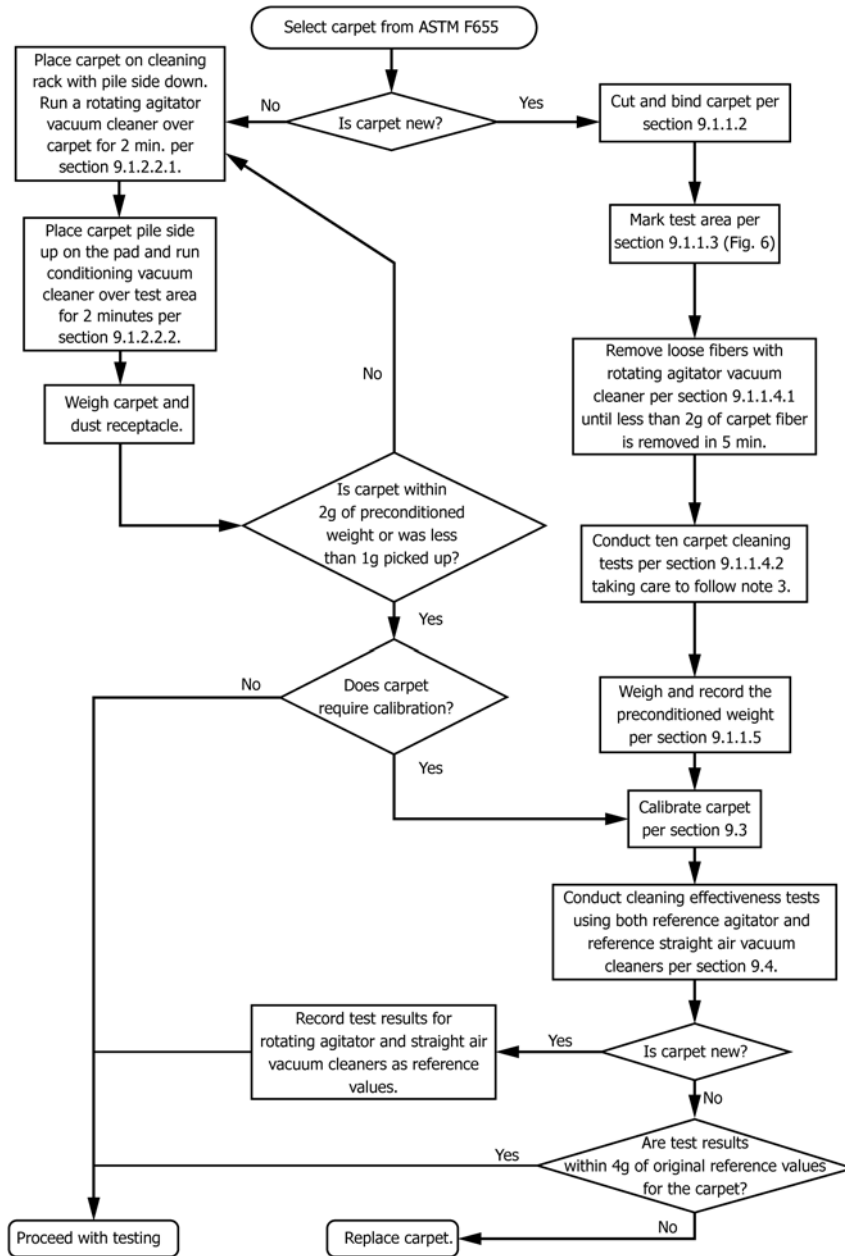
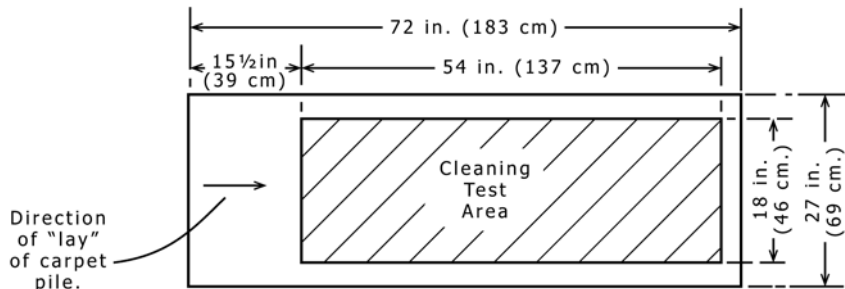

FIG. 4 Carpet Conditioning/Calibration Procedure



NOTE 1—Cleaning test area should be positioned as shown. First forward stroke of rotating agitator or carpet is in direction *with* lay of carpet.

FIG. 5 Test Carpet

agitator conditioning vacuum cleaner for 2 min, concentrating on the test area; then run the rotating agitator vacuum cleaner

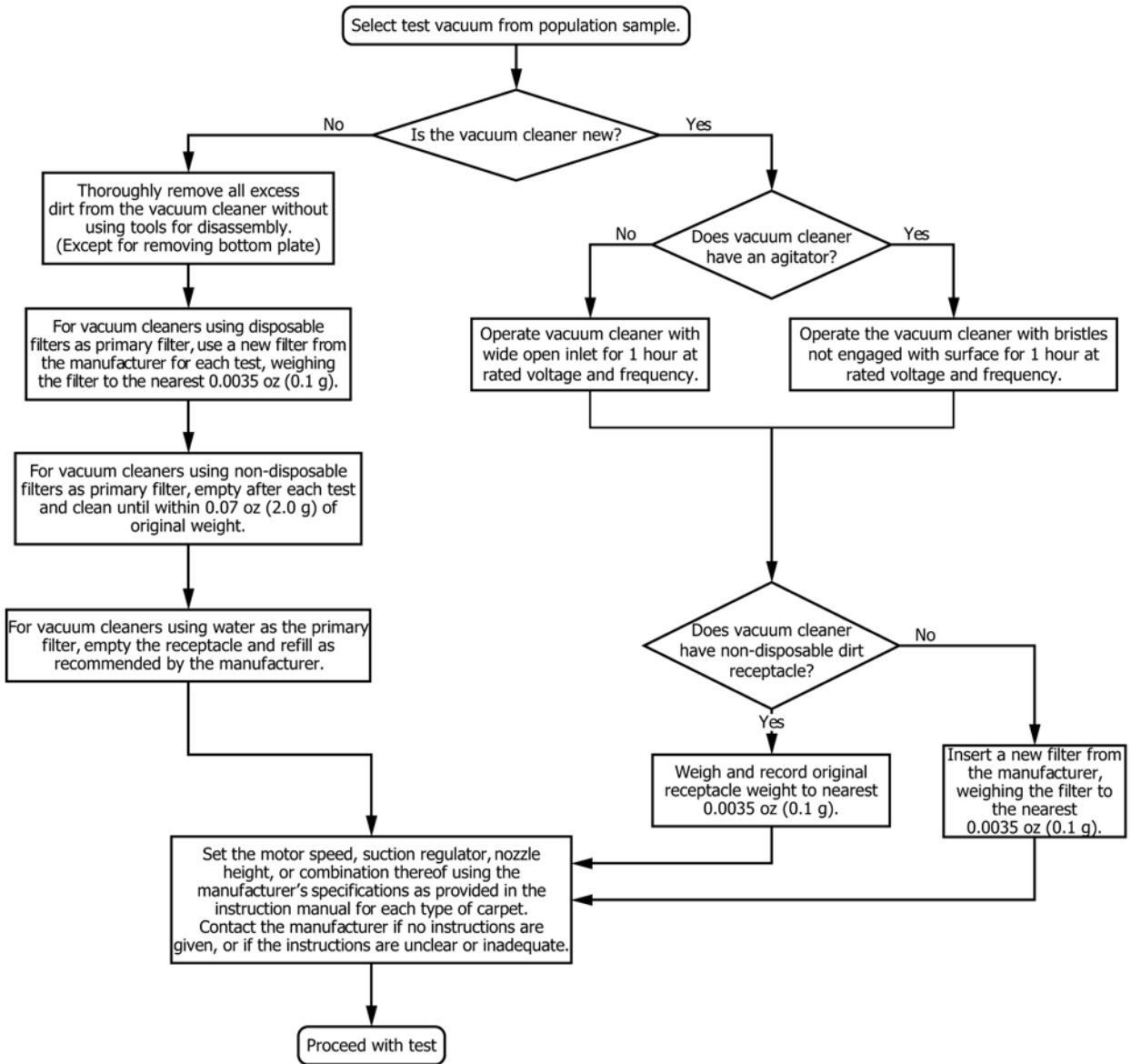

FIG. 6 Vacuum Cleaner Conditioning Procedure

thoroughly over the entire area at least one time.

(3) Weigh the carpet.

(4) Keep alternating 9.1.2.3(1) and 9.1.2.3(2), always ending with the pile side up, until the carpet weight meets the requirement of 9.1.2.1 or 9.1.2.2.

(5) Change the disposable primary filter after a maximum of every 4 runs on the conditioning vacuum cleaner or more often if required.

(6) Reconditioning equipment that uses nondisposable filters should have the filter or filters cleaned after every four carpet reconditioning runs or more often, if required.

NOTE 4—A high-cleaning performance rotating agitator vacuum cleaner is recommended for reducing the time to recondition the carpet.

9.1.3 Reconditioning Used Carpet Padding:

9.1.3.1 Clean the carpet padding by shaking weekly or more often, if necessary, to remove any collected dirt.

9.1.3.2 Replace the carpet padding when it has holes, tears, or other signs of wear.

9.2 Preparation of Test Systems and Cleaning Tools (see Fig. 6):

9.2.1 New Test Systems and Cleaning Tools:

9.2.1.1 Run the system in at rated voltage $\pm 1\%$ and rated frequency with filters in place.

(1) If a rotating agitator type cleaning tool is included with the system operate it for 1 h with agitator bristles not engaged on any surface.

9.2.1.2 For vacuum cleaners with non-disposable dirt receptacles, weigh and record the receptacle's original weight to the nearest 0.0035 oz (0.10 g). This may not be possible with some systems in which the nondisposable filter cannot be removed.

9.2.2 Used Test Vacuum Cleaners:

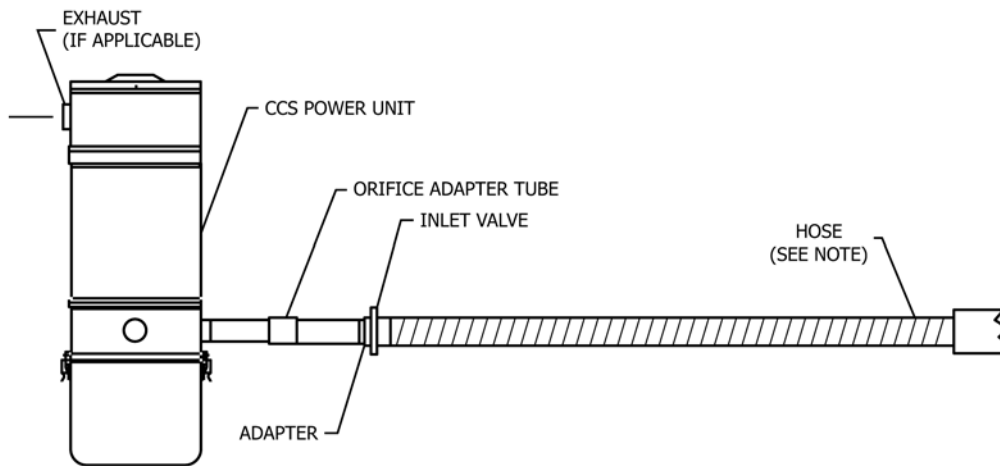

NOTE 1—Due to the height required for the tubing assembly, the assembly (in a plane) can be at any angle from vertical to parallel with the floor.
 NOTE 2— If flexible tubing is used for pipe sections, then flexible tubing must be supported in a straight line.
 NOTE 3—Hose is to be laid out in a straight line so as to minimize kinks or bends.

FIG. 7 Vacuum Cleaning System Test Set-Up

9.2.2.1 Recondition a used test vacuum cleaner, prior to each test run, as follows:

(1) Thoroughly remove excess dirt from the test system. Without using tools for disassembly, clean the entire outer surface, brushes, nozzle chamber, ductwork, inside of the chamber surrounding the primary filter, and inside hose and wands. Check the condition of all mechanisms for signs of wear or damage. (See Note 5.)

(2) For systems using disposable filters as the primary filters, use a new disposable primary filter from the manufacturer for each test run. Weigh the filter to the nearest 0.0035 oz (0.10 g) and install it as recommended by the vacuum cleaner manufacturer. Thoroughly clean the inside of the chamber surrounding the primary filter each time the filter is replaced.

(3) For systems using cloth filter bags or other types of nondisposable dirt receptacles, empty according to manufacturer's instructions after each test run, and clean the cloth filter bag or nondisposable dirt receptacle until its weight is within 0.07 oz (2 g) of its original weight. Thoroughly clean the inside of the chamber surrounding the primary filter. Weigh the receptacle to the nearest 0.0035 oz (0.10 g) and install it as recommended by the vacuum cleaner manufacturer.

NOTE 5—It is recommended that a replaceable brush drive belt for cleaning tool agitators be changed after each four test runs, if considered applicable, using manufacturer's instructions. Any other maintenance task, such as cleaning the brush belt with distilled water, should only be done in accordance with manufacturer's recommendations.

9.2.3 Test System and Tool Settings:

9.2.3.1 If various settings are provided, set the motor speed setting, suction regulator, nozzle height, or combination thereof using the manufacturer's specifications as provided in the instruction manual for each type of carpet. Contact the manufacturer if no instructions are given, or if the instructions are unclear or inadequate.

9.2.3.2 All straight line movement (see Test Method F1409), sound power (see Test Method F1334), and motor life evaluation (see Specification F655 and Test Methods F884,

F922, and F1038) tests shall be conducted using the same settings (nozzle, motor speed, suction regulator, etc.) for each specific carpet.

9.2.4 Reference Vacuum Cleaners or Systems (Calibration):

9.2.4.1 Use the reference vacuum cleaners or systems only for determining the reference rating of carpets and for the verification of carpet acceptability (see 9.3).

9.2.4.2 Maintain the performance of the reference vacuum cleaners or systems throughout the acceptable life of the carpet (that is, nozzle suction, bristle extension, motor and agitator speeds, etc...).

9.3 Test Carpet Calibration:

9.3.1 The purpose of calibration is to determine when the test carpet needs to be replaced by establishing a reference rating for each new preconditioned test carpet and to check this rating 50 or fewer test runs.

9.3.2 The reference ratings are determined for each test carpet by the percent pickup using the reference rotating agitator vacuum cleaner or system and the reference straight-air vacuum cleaner or system.

9.3.3 The percent pickup is determined by performing a carpet-embedded dirt removal effectiveness test (see 9.4).

9.3.4 When the embedded dirt rating for either reference cleaner varies by 0.14 oz (4 g) from the original reference rating for the carpet, replace the carpet.

NOTE 6—Carpet pick up changes over time as the test carpet panel is used due to normal carpet wear. General laboratory practice is to track and record the number of test runs on each carpet panel. It is recommended to estimate, as closely as possible, the number of required test runs on all carpet panels intended to be used prior to starting any test program in order to establish that the selected carpet panels have a sufficient number of test runs left to complete the test program. All products being tested in a comparison test must be tested on the same calibrated carpet panel throughout the test program. If a particular carpet panel is found to no longer be acceptable for testing due to the 0.14 oz (4 g) limit being exceeded during a calibration check, all products tested on that particular carpet panel during the test program must be retested on the new carpet panel to ensure proper comparison.

9.4 Carpet Embedded Dirt Removal Effectiveness Test:

9.4.1 Set up the system as shown in Fig. 7. On the intake side, use an orifice tube adapter terminating with a wall inlet valve. Insert into the wall valve a flexible cleaning hose as provided with the system. The hose, wands, and nozzle should be those normally offered with the particular unit being tested. If more than one hose, wand, or nozzle type is offered with the unit, the manufacturer’s part, catalog or model number of the ductwork, fittings, hose, wands, and nozzle used in the test must be recorded and presented as part of the cleaning effectiveness rating.

9.4.2 For those systems which include exhaust tubing and muffler, their use will be mandatory for testing.

NOTE 7—If necessary, the power unit may be positioned outside the test laboratory environment.

9.4.3 Prepare test carpets in accordance with 9.1.1 for new carpets or 9.1.2 for used carpets.

9.4.4 If preconditioning or reconditioning has been done more than 1 h before a test run, weigh the carpet. If the weight of the carpet exceeds the preconditioned or reconditioned weight by more than 0.07 oz (2 g), clean the carpet with a rotating agitator conditioning vacuum cleaner until these criteria are met.

9.4.5 Carefully weigh the test carpet immediately before placing it on the test platform. Record the weight to the nearest 0.035 oz (1.0 g).

9.4.6 Position the test carpet on the padding (with “scrim” side of the padding up) on the supporting surface (see 5.11).

9.4.7 The test cleaners and dirt receptacles should be prepared in accordance with Section 9.2.

9.4.8 Weigh the prepared dirt receptacle (that is, dust bag or other primary filter device) prior to conducting the measurement test run. Record the weight to the nearest 0.0035 oz (0.10 g).

9.4.9 Install the primary filter as explained below.

9.4.9.1 For vacuum cleaners using disposable or non-disposable primary filters, install the primary filter from the manufacturer per their instructions.

9.4.10 Ensure that the vacuum cleaner settings have been made in accordance with 9.2.3.

9.4.11 *Test Dirt Preparation*—Weigh and mix 3.17 ± 0.0035 oz (90 ± 0.1 g) of silica sand and 0.35 ± 0.0035 oz (10 ± 0.1 g) of commercial grade talcum, both conforming to the specifications found in Annex A1.

9.4.11.1 Silica Sand shall be sieved to assure conformance to the specification of A1.2. Sieving shall be performed in accordance with Test Method D75.

9.4.11.2 Bulk mixing and storage of sieved constituents of silica sand is acceptable if assay analysis meets the specification of A1.2.

9.4.11.3 Bulk storage of test dirt mixture (sand plus talc) is not allowed.

9.4.12 Distribute 3.52 oz (100 g) of the test dirt uniformly on the cleaning test area (see Fig. 5), using any convenient spreading method.

9.4.13 Embed the test dirt into the carpet using the dirt embedment tool shown in Fig. 1. Perform the embedding process by using a dragging motion in both directions with the

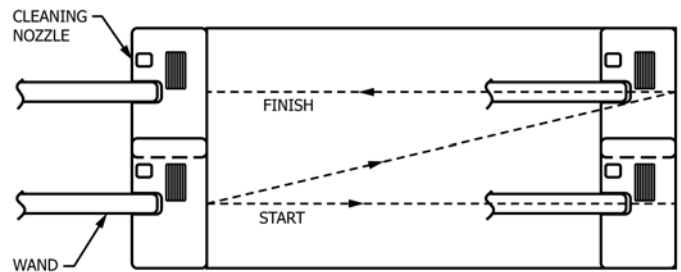

NOTE 1—Shown are the nozzle positions for the cleaning pattern when $N = 2$ (refer to Annex A2).

FIG. 8 Cleaning Nozzle Position at Start and Finish of Test Cleaning Strokes

handle held at the angle shown. Drag the dirt embedment tool over the test area exactly 30 strokes, alternating directions forward and back. (A movement in one direction is one “stroke.”) Use a uniform movement to provide a “stroke” time of 2.5 s (a rate of 1.8 ft/s (0.55 m/s)). The first forward stroke shall be in the direction of the carpet lay.

NOTE 8—An acceptable laboratory practice shall be used to ensure that the embedment tool shall not fall short of reaching the end boundaries of the test area, and the tool shall cover both side boundaries of the test area at all times.

9.4.14 Clean the embedding tool as needed.

9.4.15 If the system or cleaning tool has not been energized for more than 60 min, energize the system or cleaning tool for 2 min at nameplate rated voltage ($\pm 1\%$) and frequency (± 1 Hz) immediately preceding the test sequence of 9.4.12. For systems and cleaning tools with dual nameplate voltage ratings, conduct testing at the highest voltage.

9.4.15.1 For a rotating agitator-type cleaning tools, place it such that the bristles clear the supporting surface and no loose dirt is picked up.

9.4.15.2 For a straight-air system or cleaning tool, operate with the rug tool unrestricted, positioned such that no loose dirt is picked up from the supporting surface.

9.4.16 Immediately following the 2-min “run-in” of 9.4.11, de-energize the vacuum cleaner and place the vacuum cleaner nozzle on the test carpet so that the front edge of the vacuum cleaner coincides with the line defining the beginning of the test area and the right side of the boundary of the 18-in. test width (see Fig. 8). The forward stroke of the nozzle shall be in the direction of the carpet lay (see Fig. 5).

9.4.16.1 Reasonable efforts shall be made to maintain the handle height at 31.5 in. (0.8 m) during each test run for cleaning tools with a pivoting handle.

9.4.16.2 Reasonable efforts shall be made to maintain the cleaning tool’s nozzle parallel to the test carpet surface during each test run for vacuum cleaners with non-pivoting handles.

9.4.17 Tilt or lift the nozzle off the carpet, energize the system, and adjust the voltage to rated voltage $\pm 1\%$. Allow the system to run and expand the filter bag, if one is present.

9.4.18 *Test Cleaning Pattern*:

9.4.18.1 For a rotating agitator-type cleaning tool, lower the nozzle onto the carpet before the test area. Again, adjust the voltage to rated voltage $\pm 1\%$; then move the nozzle at a rate of 1.8 ft/s (0.55 m/s) in the test cleaning pattern and motion as

specified in [Annex A2](#) during the cleaning cycle. Maintain the nozzle position and settings as specified in [9.2.3](#) during the cleaning cycle.

9.4.18.2 For a straight-air cleaning tool, position the nozzle on the carpet before the test area. Again, adjust the voltage to rated voltage $\pm 1\%$; then move the nozzle at a rate of 1.8 ft/s (0.55 m/s) in the test cleaning patterns and motion as described in [Annex A2](#). Maintain the nozzle position and settings as specified in [9.2.3](#) during the cleaning cycle.

9.4.18.3 At the end of the last stroke, smoothly tilt or lift the cleaning tool nozzle off the carpet and allow the system to run an additional 10 s to clear the system of test dirt actually picked up but temporarily trapped within it before de-energizing the system. During the additional run period, the hose used with the system should be flexed to help clear the system.

9.4.19 Determine the grams of dirt picked up by subtracting the weight of the dirty carpet after test from the weight of the preconditioned or reconditioned carpet at the start of the test plus 3.53 oz (100 g). Record the results to the nearest 0.035 oz (1.0 g).

9.4.20 Using the same test central vacuum cleaning system, repeat [9.4.1 – 9.4.18](#) two additional times for a total of three test runs.

NOTE 9—If after the first three tests on a new central vacuum cleaning system sample, the repeatability limits are not met due to the results of the first test run, the first test run may be discarded and replaced with an additional test run.

9.4.21 The percent carpet-embedded dirt removal effectiveness for each individual test vacuum cleaner from the population sample for a given carpet is the average of three test runs

meeting the repeatability statement in Section 10. See [A3.3](#) for a procedural example and whether further test runs need to be conducted.

9.4.22 The percent carpet-embedded dirt removal effectiveness for each individual vacuum cleaner from the population sample is the geometric mean of the individual carpet values. See [Annex A3](#) for a procedural example on calculating the geometric mean.

9.4.23 A minimum of two additional test sample units of the same model shall be selected in accordance with the sampling statement of Section 7. Repeat [9.4.1 – 9.4.20](#) for each new test sample unit selected.

9.4.24 The percent carpet-embedded dirt removal effectiveness for the population of the vacuum cleaner model being tested is the arithmetic mean of geometric mean values of the percent carpet-embedded dirt removal effectiveness from a sample of the population meeting the requirements of the sampling statement (Section 7).

10. Precision and Bias

10.1 No interlaboratory tests have been performed; therefore, no precision statements regarding the repeatability and reproducibility of this test method are available at this time. The precision statements are expected to be close to those given for Test Method [F608](#), upon which this test method is based.

10.2 *Bias*—No justifiable statement can be made on the accuracy of this test method since the true value of the property cannot be established by an acceptable referee method.

11. Keywords

11.1 central vacuum cleaner; dirt removal

ANNEXES

(Mandatory Information)

A1. TEST DIRT

A1.1 Test Dirt, 100 g, consisting of the following:

A1.1.1 *Item 1*—3.17 oz (90 g) of silican sand⁵ in accordance with [A1.2](#).

A1.1.2 *Item 2*—0.35 oz (10 g) of commercial grade talcum⁶ in accordance with [A1.3](#).

A1.2 Silica sand in the following particle size range and amounts:

⁵ Wedron No. 540 Unground Silica Sand, or the equivalent, has been found satisfactory for this purpose. It is available from the Wedron Silica Co., Customer Service Dept., P.O. Box 119, Wedron, IL 60557. The test dirt must be sieved to ensure conformance with the analysis limits. Use Practice [D75](#).

⁶ USP Grade Supreme Talc, or the equivalent, has been found satisfactory for this purpose. It is available from Fischer Scientific Co., 1600 West Glen Ave., Box 171, Itasca, IL 60143.

Sieve Range, U.S. No.	Particle Size, μm	Amount Used, g
-30/+40	600 to 425	0.9
-40/+50	425 to 300	31.5
-50/+70	300 to 212	41.4
-70/+100	212 to 150	13.5
-100/+140	150 to 106	2.7

A1.3 Commercial grade talcum with the following particle size distribution:

Particle Size Range, μm	Destination by Weight, %
>44	0.5
43.9 to 20	12.5
19.9 to 10	27.0
9.9 to 5	23.0
4.9 to 2	20.0
1.9 to 1	8.0
<0.9	9.0

A2. TEST CLEANING PATTERN AND TIME

A2.1 *General*—All vacuum cleaners, regardless of the width of their nozzles, shall be moved back and forth in a specified pattern on the 54 by 18-in. (1370 by 460-mm) test area of the carpet for a total of exactly 16 strokes at the rate of 2.5 s per stroke, for a total time of 40 ± 1 s, using any acceptable laboratory method to assure that these specifications are met. Examples of methods that have been found acceptable are visible-marked timing belt or a stopwatch to measure stroke time and cumulative time.

A2.1.1 Measure the outside width of the nozzle housing in inches.

A2.1.2 Divide the nozzle width into 18 and round the result to the nearest larger whole number identified henceforth as N .

A2.1.3 Divide the width of test area 18 in. (457.2 mm) into N equal strips and mark the test area accordingly. Note that for any vacuum cleaners having overall nozzle widths ranging

from 3 to 17 in. (76.2 to 431.8 mm) the number of strips will be either 6, 5, 4, 3, or 2.

A2.1.4 Place the vacuum cleaner nozzle on the test carpet so that the front edge of the vacuum cleaner nozzle lip coincides with the line defining the beginning of the test area and the right side of the nozzle coincides with the right side boundary shown in the applicable illustration. Ensure that each forward stroke ends with the vacuum cleaner nozzle coincident with the end of the test area. When the vacuum cleaner reaches the extreme left strip, align the left side of the nozzle with the left side boundary of the test area (see Fig. 7). This shows the pattern for $N = 2$. For variations of the pattern where $N = 2$ to $N = 6$, see Fig. A2.1. Take care to ensure that during each stroke, the side of the nozzle, right side or left side as applicable, is kept aligned with the side boundary of the test strip being cleaned, except for crossover strokes.

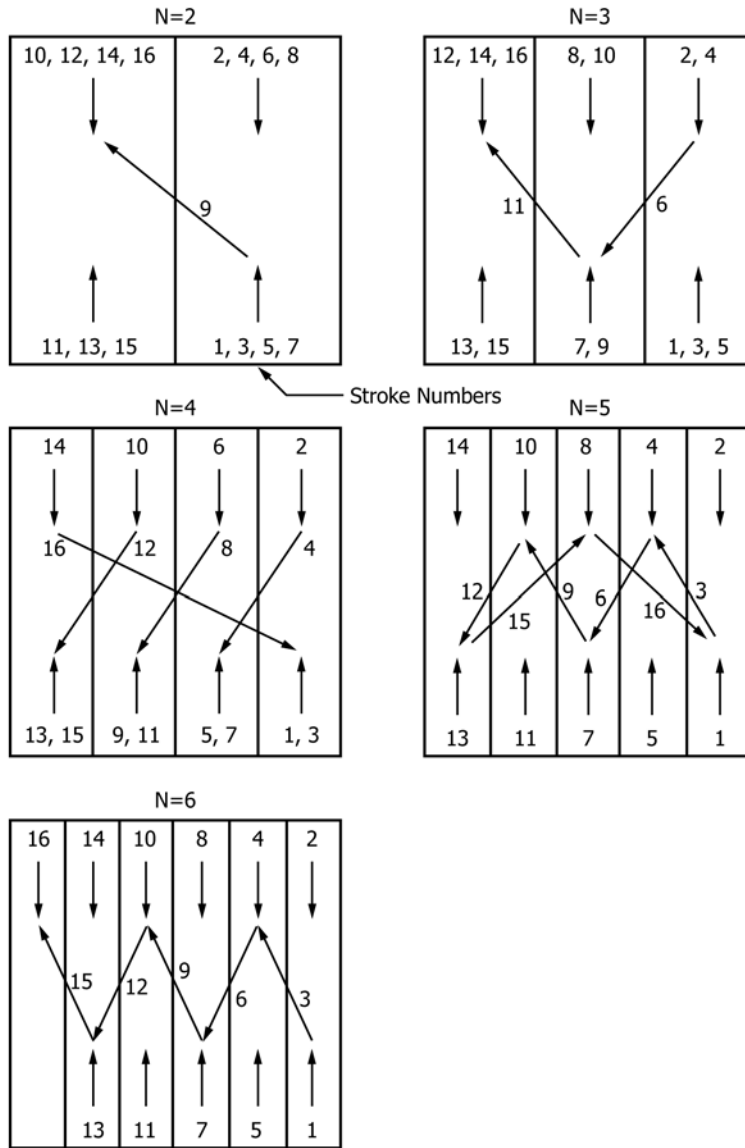

NOTE 1—The diagonal strokes shown in each pattern indicate that the test nozzle is moved from one stroke to another during the diagonal stroke. There is no specific start or end point for the diagonal movement of the test nozzle during the diagonal stroke.

FIG. A2.1 Test Cleaning Patterns

A3. DETERMINATION OF THE POPULATION MEAN HAVING A 90 % CONFIDENCE INTERVAL

A3.1 Theory

A3.1.1 The most common and ordinarily the best estimate of the population mean, μ , is the arithmetic mean, \bar{X} , of the individual scores (measurements) of the units comprising a sample taken from the population. The average score of these units will seldom be exactly the same as the population mean; however, it is expected to be fairly close so that in using the following procedure it can be stated with 90 % confidence that the true mean of the population, μ , lies within 5 % of the calculated mean, \bar{X} , of the sample taken from the population.

A3.1.2 The following procedure provides a confidence interval about the sample mean which is expected to bracket μ , the true population mean, 100(1 - a)% of the time where a is the chance of being wrong. Therefore, 1 - a is the probability or level of confidence of being correct.

A3.1.3 The desired level of confidence is 1 - a = 0.90 or 90 % as stated in Section 7. Therefore, a = 0.10 or 10 %.

A3.1.4 Compute the mean, \bar{X} , and the standard deviation, s, of the individual scores of the sample taken from the population:

TABLE A3.1 Percentiles of the *t* Distribution

df	<i>t</i> _{0.95}
1	6.314
2	2.920
3	2.353
4	2.132
5	2.015
6	1.943
7	1.895
8	1.860
9	1.833
10	1.812
11	1.796
12	1.782
13	1.771
14	1.761
15	1.753

$$\bar{X} = \frac{1}{n} \sum_{i=1}^n X_i \quad (A3.1)$$

$$s = \sqrt{\frac{n \sum_{i=1}^n X_i^2 - \left(\sum_{i=1}^n X_i\right)^2}{n(n-1)}}$$

where:

- n* = number of units tested, and
- X_i* = the value of the individual test unit score of the *i*th test unit. As will be seen in the procedural example to follow, this is the average value of the results from three test runs performed on an individual test unit with the resulting set of data meeting the repeatability requirements of Section 7.

A3.1.5 Determine the value of the *t* statistic for *n* – 1 degrees of freedom, df, from **Table A3.1** at a 95 % confidence level.

NOTE A3.1—The value of *t* is defined as *t*_{1–*a*/2} and is read as “*t* at 95 % confidence.”

$$t \text{ statistic} = t_{1-a/2} = t_{0.95} \quad (A3.2)$$

where:

$$1 - a/2 = 1 - 0.10/2 = 1 - 0.05 = 0.95, \text{ or } 95 \%$$

A3.1.6 The following equations establish the upper and lower limits of an interval centered about \bar{X} that will provide the level of confidence required to assert that the true population mean lies within this interval:

$$CI_U = \bar{X} + ts/\sqrt{n} \quad (A3.3)$$

$$CI_L = \bar{X} - ts/\sqrt{n}$$

where:

- CI* = confidence interval (U – upper limit; L – lower limit),
- X* = mean score of the sample taken from the population,
- t* = *t* statistic from **Table A3.1** at 95 % confidence level,
- s* = standard deviation of the sample taken from the population, and
- n* = number of units tested.

A3.1.7 It is desired to assert with 90 % confidence that the true population mean, μ , lies within the interval, *CI_U* to *CI_L*, centered about the sample mean, \bar{X} . Therefore, the quantity

ts/\sqrt{n} shall be less than some value, *A*, which shall be 5 % of \bar{X} in accordance with the sampling statement of 7.1.

A3.1.8 As $n \rightarrow \infty$, $ts/\sqrt{n} \rightarrow 0$. As this relationship indicates, a numerically smaller confidence interval may be obtained by using a larger number of test units, *n*, for the sample. Therefore, when the standard deviation, *s*, of the sample is large and the level of confidence is not reached after testing three units, a larger sample size, *n*, shall be used.

A3.2 Procedure

A3.2.1 Select three units from the population for testing as the minimum sample size.

A3.2.2 Obtain individual test unit scores with one of the following methods. The data set resulting from the three test runs performed on each individual test unit for each individual carpet shall meet the respective repeatability requirement found in Section 10.

A3.2.3 Compute \bar{X} and *s* of the sample.

A3.2.3.1 *Geometric Mean*—Calculate the geometric mean of the average results of three test runs performed on all carpets specified in Specification **F655** for each of the three individual test units. (See **Fig. A3.1**.)

A3.2.3.2 *Individual Carpets*—Calculate the arithmetic mean of the results of three test runs performed on each of the carpets tested for each of the three individual test units. (See **Fig. A3.2**.)

A3.2.4 Compute the value of *A* where $A = 0.05 (\bar{X})$.

A3.2.5 Determine the statistic *t* for *n* – 1 degrees of freedom from **Table A3.1** where *n* = number of test units.

A3.2.6 Compute ts/\sqrt{n} for the sample and compare it to the value to *A*.

A3.2.7 If the value of $ts/\sqrt{n} > A$, an additional unit from the population shall be selected and tested, and the computations of **A3.2.2 – A3.2.6** repeated.

A3.2.8 If the value of $ts/\sqrt{n} < A$, the desired 90 % confidence level has been obtained. The value of the final \bar{X} may be used as the best estimate of the cleaning ability rating for the population.

A3.3 Examples

A3.3.1 The following data is chosen to illustrate how the value of embedded dirt cleaning ability for the population of an agitator type vacuum cleaner model, tested on ASTM Plush carpet, is derived. For this particular carpet, the measured test results from three test runs on each unit are required to have a repeatability limit not exceeding 2.816 as indicated in Table 1.

A3.3.2 Select three test units from the vacuum cleaner model population. A minimum of three test runs shall be performed using each test run.

A3.3.3 Test run scores for test unit No. 1 on the Plush carpet:

- Test Run No. 1 = 60.5
- Test Run No. 2 = 62.7
- Test Run No. 3 = 65.3

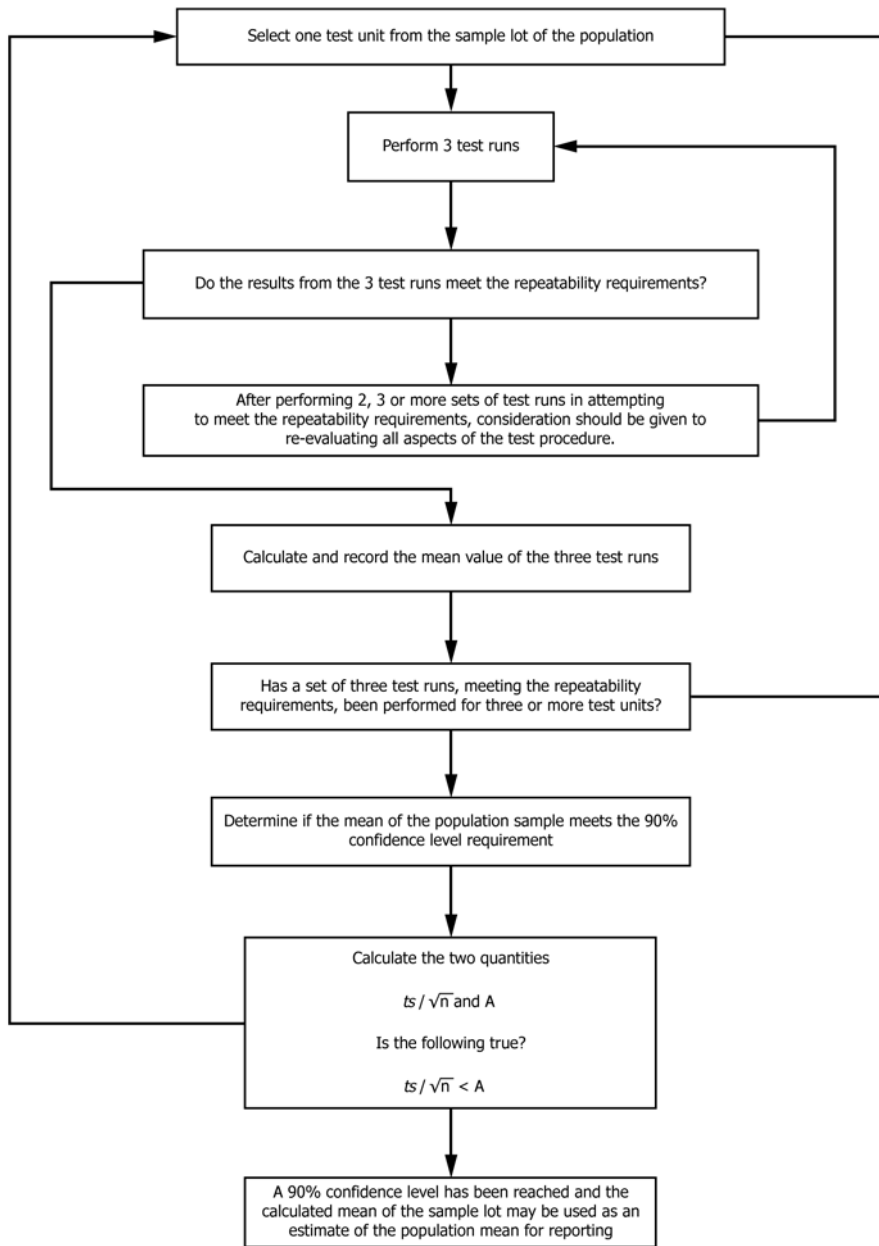

FIG. A3.1 Testing Procedure Flowchart

A3.3.4 Maximum spread = $65.3 - 60.5 = 4.8$. This value is greater than the repeatability limit required in Table 1. The results shall be discarded and three additional test runs performed. If after the first three tests on a new vacuum cleaner sample, the repeatability limits are not met due to the results of the first test run, the first test run may be discarded and replaced with an additional test run.

A3.3.5 Test run scores for test unit No. 1 on the Plush carpet:

Test Run No. 1 = 64.9
 Test Run No. 2 = 65.1
 Test Run No. 3 = 65.8

A3.3.6 Maximum spread = $65.8 - 64.9 = 0.9$. This value is less than the repeatability limit requirement of Table 1.

A3.3.7 Unit No. 1 score for Plush carpet = $(64.9 + 65.1 + 65.8)/3 = 65.27$.

NOTE A3.2—If it is necessary to continue repeated test run sets (7, 8, 9–10, 11, 12—etc.) because the spread of data within a data set is not less than the repeatability limit requirement stated in Table 1, there may be a problem with the test equipment, the execution of the test procedure, or any of the other factors involved in the test procedure. Consideration should be given to re-evaluating all aspects of the test procedure for the cause(s).

A3.3.8 Testing the 90 % Confidence Interval for Individual Carpet Scores:

A3.3.8.1 A minimum of two additional test units must be tested, each meeting the repeatability limit requirement. For this procedural example, assume those units met the repeatability requirement and the individual unit scores are:

Score of Test Unit No. 1 = 65.27
Score of Test Unit No. 2 = 69.53
Score of Test Unit No. 3 = 67.41

A3.3.8.2 $\bar{X} = \frac{1}{3} (65.27 + 69.53 + 67.41) = 67.403.$

A3.3.8.3

$$s = \sqrt{\frac{3[(65.27)^2 + (69.53)^2 + (67.41)^2] - [65.27 + 69.53 + 67.41]^2}{3(3-1)}} \tag{A3.4}$$

$s = 2.130$

A3.3.8.4 $A = 0.05 (67.403) = 3.370.$

A3.3.8.5 Degrees of freedom (df), $n - 1 = 3 - 1 = 2$ $t_{0.95}$ statistic = 2.920.

A3.3.8.6

$ts/\sqrt{n} = 2.920 (2.130)/\sqrt{3} = 3.591.$

A3.3.8.7 $3.591 > 3.370$. The requirement that $ts/\sqrt{n} < A$ has not been met because s is large. Therefore, an additional test unit from the population shall be tested.

A3.3.8.8 Score of test unit No. 4 = 66.82.

A3.3.8.9 $\bar{X} = \frac{1}{4} (65.27 + 69.53 + 67.41 + 66.82) = 67.258.$

A3.3.8.10

$$s = \frac{\sqrt{4[(65.27)^2 + (69.53)^2 + (67.41)^2 + (66.82)^2] - [65.27 + 69.53 + 67.41 + 66.82]^2}}{4(4-1)} \tag{A3.5}$$

$s = 1.763$

A3.3.8.11 $A = 0.05 (67.258) = 3.363.$

A3.3.8.12 Degrees of freedom (df), $n - 1 = 4 - 1 = 3$ $t_{0.95}$ statistic = 2.353.

A3.3.8.13 $ts/\sqrt{n} = 2.353 (1.763)/\sqrt{4} = 2.075.$

A3.3.8.14 $2.075 < 3.363$ (meets requirements).

A3.3.8.15 Thus, the value of \bar{X} , 67.26, represents the embedded dirt cleaning ability score for the vacuum cleaner model tested on the given carpet and may be used as the best estimate of the cleaning ability rating for the population mean on that carpet.

A3.3.9 Calculating the Geometric Mean:

A3.3.9.1 To gain the geometric mean for an individual sample, a minimum of three test runs shall be conducted on each of the other test carpets. These scores shall meet the repeatability requirements listed in Table 1.

A3.3.9.2 Assuming that the unit being tested met the repeatability requirements for each of the carpet samples specified in Specification F655, the following scores were obtained:

Carpet Sample	Score
Plush	65.27
Multilevel	59.31
Level Loop	74.25
Shag	9.3

A3.3.9.3 The geometric mean for all of the carpets specified in Specification F655 for each test unit can be calculated using the following formula:

$$\text{Geometric Mean} = \sqrt[n]{X_1 \cdot X_2 \cdot X_3 \cdot \dots \cdot X_n} \tag{A3.6}$$

A3.3.9.4 For our example the geometric mean would be equal to:

$$\text{Geometric Mean} = \sqrt[4]{65.27 \times 59.31 \times 74.25 \times 9.3} = 40.43 \tag{A3.7}$$

A3.3.10 Testing the 90 % Confidence Interval for Geometric Mean Scores:

A3.3.10.1 A minimum of two additional test units must be tested. For this procedural example, assume those units met the repeatability requirements for each carpet sample and the individual unit scores are:

A3.3.10.2

$\bar{X} = \frac{1}{3} (40.43 + 43.41 + 41.23) = 41.69$

A3.3.10.3

$$s = \frac{\sqrt{3[(40.43)^2 + (43.41)^2 + (41.23)^2] - [40.43 + 43.41 + 41.23]^2}}{3(3-1)} = 1.54$$

A3.3.10.4 $A = 0.05 (41.69) = 2.08$

A3.3.10.5 Degrees of freedom, $n - 1 = 3 - 1 = 2$; $t_{0.95}$ statistic = 2.920.

A3.3.10.6 $ts/\sqrt{n} = 2.920 (1.54)/\sqrt{3} = 2.60.$

A3.3.10.7 $2.60 > 2.08$. The requirement that $ts/\sqrt{n} < A$ has not been met because s is larger. Therefore, an additional test unit from the population shall be tested.

A3.3.10.8 Score of test unit No. 4 = 41.64.

A3.3.10.9 $\bar{X} = \frac{1}{4} (40.43 + 43.41 + 41.23 + 41.64) = 41.68.$

A3.3.10.10

$$s = \frac{\sqrt{4[(40.43)^2 + (43.41)^2 + (41.23)^2 + (41.64)^2] - [40.43 + 43.41 + 41.23 + 41.64]^2}}{4(4-1)} = 1.26$$

A3.3.10.11 $A = 0.05 (41.68) = 2.08.$

A3.3.10.12 Degrees of freedom, $n - 1 = 4 - 1 = 3$; $t_{0.95}$ statistic = 2.353.

A3.3.10.13 $ts/\sqrt{n} = 2.353 (1.26)/\sqrt{4} = 1.48.$

A3.3.10.14 $1.48 < 2.08$ (meets requirements).

A3.3.10.15 Thus, the value of \bar{X} , 41.68, represents the embedded dirt cleaning ability score for the vacuum cleaner model tested and may be used as the best estimate of the cleaning ability rating for the population mean across all the carpets specified in Specification F655.

APPENDIX

(Nonmandatory Information)

X1. IN-HOME CLEANING TEST

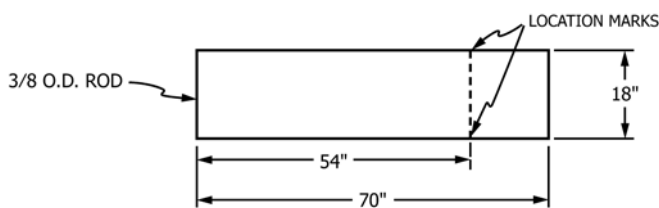

FIG. X1.1 Frame for In-Home Cleaning Test

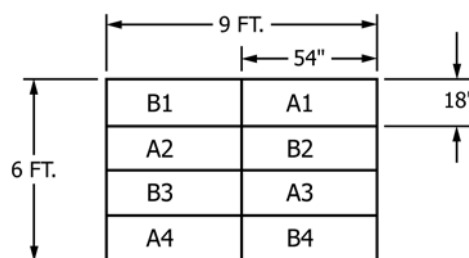

FIG. X1.2 Test Area

X1.1. Scope

X1.1.1 The purpose of this test is to determine a ratio of a carpet-embedded dirt removal effectiveness and a home-carpet embedded removal effectiveness rating which can be used for comparing one or more vacuum cleaners against a standard vacuum cleaner and determining correlation with laboratory ASTM tests. The results are representative of the geographic area covered by the test homes.

X1.2. Summary of Test Method

X1.2.1 Each vacuum cleaner is tested in 25 homes in comparison with a standard vacuum cleaner. The grams of dirt picked up from the carpet in each home by each vacuum cleaner are accurately weighed. Each vacuum cleaner is manipulated over four segments of carpet 18 by 54-in. for 40 s per segment. The ratio of carpet-embedded dirt removal effectiveness equals the ratio of dirt picked up by the test vacuum cleaner (*B*) divided by dirt picked up by the standard vacuum cleaner (*A*). The home vacuum cleaning effectiveness rating of vacuum cleaner (*B*) to that of vacuum cleaner (*A*) is the geometric mean of the values obtained in the 25 individual tests performed.

X1.3. Significance and Use

X1.3.1 The ratio of carpet-embedded dirt removal effectiveness for specific vacuum cleaner determined by “in-home” tests can be compared to “in-laboratory” tests for correlation.

X1.4. Apparatus

X1.4.1 *Standard Vacuum Cleaner for Comparison*, either upright canister.

X1.4.2 *Frame*, inside effective area 18 by 54 in. (see Fig. X1.1):

X1.4.3 *Stop Watch*.

X1.4.4 *Canister Vacuum Cleaner*, for conditioning vacuum cleaners between tests and for finishing cleaning the remaining test area.

X1.4.5 *Dust Bags*, for appropriate vacuum cleaners.

X1.4.6 *Polyethylene Bags*, for sealing and transporting dust bags.

X1.4.7 *Balance Scale*, for weighing dust bags to within ± 0.01 g.

X1.4.8 *Test Vacuum Cleaner*.

X1.4.9 *Homes*, 25 with carpeted area for selecting 6-ft area. This area shall not be obstructed to traffic by furniture or scatter rugs. Test homes should be located randomly throughout the graphic test area.

X1.4.10 *Adjustable Transformer*, for adjusting or controlling a voltage to the vacuum cleaner.

X1.4.11 *Voltmeter*, to measure input volts to the vacuum cleaner, provide measurements accurate to within ± 1 %.

X1.4.12 *Ammeter*, to measure input current to the vacuum cleaner, provide measurements accurate to within ± 1 %.

X1.4.13 *Manometer* (or equivalent pressure-sensing device), to ensure sealed suction of the vacuum cleaner, to provide measurements in inches of water accurate to within ± 0.10 in.

X1.4.14 *Tachometer(s)*, to measure motor speed in rpm and to ensure speed of agitator brush in rpm, accurate to ± 1 %.

X1.5. Procedure

X1.5.1 Identify standard unit and test unit, such as model number, serial number, and unit test number.

X1.5.2 *Initial Performance Check*—Check the test vacuum cleaner and the reference vacuum cleaner in the laboratory prior to the test, for functional properties. For this test, operate each vacuum cleaner at rated voltage on the ASTM plenum chamber using a 1¼-in. diameter orifice for upright vacuum cleaners and a ¾-in. diameter orifice for canister vacuum cleaners. Record the input current in amperes, motor speed in rpm, agitator speed in rpm, sealed suction, and agitator brush extension.

X1.5.3 Each day prior to testing in the home, check sealed suction, amperes, and brush rpm.

X1.5.4 Each vacuum cleaner is tested in 25 homes, in comparison to a standard vacuum cleaner. The test area is a 9 by 6-ft area made up of eight sections, each 18 by 54 in. (see Fig. X1.2). Areas *A* are cleaned by the known standard vacuum

cleaner. Areas B are cleaned by the vacuum cleaner being tested. Bulky litter, such as hair pins, string, paper, etc., should be removed manually from the test area. The nozzle heights on the test and reference vacuum cleaners should be set in accordance with the specification under “Test Vacuum Cleaner Setting” in this test method.

X1.5.5 Each segment (A_1 , A_2 , or B_1 , etc.) should be cleaned using the same pattern of strokes, stroke time, and total time as established in this test method.

X1.5.6 The sequence of cleaning the segments of the carpet test area should be A_1 , A_2 , A_3 , then A_4 with the standard vacuum cleaner, then B_1 , B_2 , B_3 , then B_4 with the test vacuum cleaner.

X1.5.7 Use the frame as a guide for cleaning the 18 by 54-in. segment.

X1.5.8 Locate the test area with regard to some reference point in the home and sketch the alternative test segments A and B . Identify the carpet as to fiber, pile height, and type. Also record if padding is used under the carpet in each home tested, and the type of padding (rubber, foam, or felt).

X1.5.9 Prior to leaving the laboratory, weigh each dust bag to the nearest ± 0.01 g and record. Seal the dust bag in a polyethylene bag. Install the bag in the vacuum cleaner just prior to test. After the test, reseal the bag for transporting until time for second weighing. Then reseal and retain the bag until test is completed.

X1.5.10 Vacuum out each test unit prior to running each home test with a standby vacuum cleaner. In the case of a canister test, vacuum out the hose, wands, and nozzle between each test.

X1.5.11 Determine the dirt weight in the dust bag for the standard and for the test vacuum cleaner.

X1.6 Data Treatment

X1.6.1 The ratio of carpet embedded dirt removal effectiveness for a single home is equal to the dirt picked up by Vacuum Cleaner B from areas $B_1 + B_2 + B_3 + B_4$ divided by the dirt picked up by Vacuum Cleaner A from areas $A_1 + A_2 + A_3 + A_4$ and is calculated as follows:

$$\text{Cleaning Effectiveness Ratio} = B/A = (A_1 + A_2 + A_3 + A_4) \quad (\text{X1.1})$$

$$B = (B_1 + B_2 + B_3 + B_4)$$

X1.6.2 The home cleaning effectiveness rating of Vacuum Cleaner B to that of Vacuum Cleaner A is the geometric mean of the values obtained in the 25 individual tests performed.

X1.7 Cleaning Effectiveness Rating:

$$N \sqrt{\left(\frac{B_1}{A_1}\right) \left(\frac{B_2}{A_2}\right) \left(\frac{B_3}{A_3}\right) \dots \left(\frac{B_N}{A_N}\right)} \quad (\text{X1.2})$$

where:

N = number of homes in which this test was conducted.

ASTM International takes no position respecting the validity of any patent rights asserted in connection with any item mentioned in this standard. Users of this standard are expressly advised that determination of the validity of any such patent rights, and the risk of infringement of such rights, are entirely their own responsibility.

This standard is subject to revision at any time by the responsible technical committee and must be reviewed every five years and if not revised, either reapproved or withdrawn. Your comments are invited either for revision of this standard or for additional standards and should be addressed to ASTM International Headquarters. Your comments will receive careful consideration at a meeting of the responsible technical committee, which you may attend. If you feel that your comments have not received a fair hearing you should make your views known to the ASTM Committee on Standards, at the address shown below.

This standard is copyrighted by ASTM International, 100 Barr Harbor Drive, PO Box C700, West Conshohocken, PA 19428-2959, United States. Individual reprints (single or multiple copies) of this standard may be obtained by contacting ASTM at the above address or at 610-832-9585 (phone), 610-832-9555 (fax), or service@astm.org (e-mail); or through the ASTM website (www.astm.org). Permission rights to photocopy the standard may also be secured from the Copyright Clearance Center, 222 Rosewood Drive, Danvers, MA 01923, Tel: (978) 646-2600; http://www.copyright.com/