



Designation: F1264 – 16^{ε1}

Standard Specification and Test Methods for Intramedullary Fixation Devices¹

This standard is issued under the fixed designation F1264; the number immediately following the designation indicates the year of original adoption or, in the case of revision, the year of last revision. A number in parentheses indicates the year of last reapproval. A superscript epsilon (ϵ) indicates an editorial change since the last revision or reapproval.

^{ε1} NOTE—Editorial changes were made throughout in November 2016.

1. Scope

1.1 This specification is intended to provide a characterization of the design and mechanical function of intramedullary fixation devices (IMFDs), specify labeling and material requirements, provide test methods for characterization of IMFD mechanical properties, and identify needs for further development of test methods and performance criteria. The ultimate goal is to develop a standard which defines performance-related mechanical characteristics of IMFDs and their fixation to bone. It is not the intention of this specification to define levels of performance or case-specific clinical performance of these devices, as insufficient knowledge to predict the consequences of the use of any of these devices in individual patients for specific activities of daily living is available. It is not the intention of this specification to describe or specify specific designs for IMFDs.

1.2 This specification describes IMFDs for surgical fixation of the skeletal system. It provides basic IMFD geometrical definitions, dimensions, classification, and terminology; labeling and material specifications; performance definitions; test methods and characteristics determined to be important to *in-vivo* performance of the device.

1.3 *Multiple test methods are included in this standard. However, the user is not necessarily obligated to test using all of the described methods. Instead, the user should only select, with justification, test methods that are appropriate for a particular device design. This may be only a subset of the herein described test methods.*

1.4 This specification includes four standard test methods:

1.4.1 Static Four-Point Bend Test Method—[Annex A1](#) and

1.4.2 Static Torsion Test Method—[Annex A2](#).

1.4.3 Bending Fatigue Test Method—[Annex A3](#).

1.4.4 Test Method for Bending Fatigue of IMFD Locking Screws—[Annex A4](#).

1.5 A rationale is given in [Appendix X1](#).

1.6 The values stated in SI units are to be regarded as standard. No other units of measurement are included in this standard.

2. Referenced Documents

2.1 *ASTM Standards*:²

[A214/A214M Specification for Electric-Resistance-Welded Carbon Steel Heat-Exchanger and Condenser Tubes](#)

[A450/A450M Specification for General Requirements for Carbon and Low Alloy Steel Tubes](#)

[D790 Test Methods for Flexural Properties of Unreinforced and Reinforced Plastics and Electrical Insulating Materials](#)

[E4 Practices for Force Verification of Testing Machines](#)

[E691 Practice for Conducting an Interlaboratory Study to Determine the Precision of a Test Method](#)

[F86 Practice for Surface Preparation and Marking of Metallic Surgical Implants](#)

[F138 Specification for Wrought 18Chromium-14Nickel-2.5Molybdenum Stainless Steel Bar and Wire for Surgical Implants \(UNS S31673\)](#)

[F339 Specification for Cloverleaf Intramedullary Pins \(Withdrawn 1998\)](#)³

[F383 Practice for Static Bend and Torsion Testing of Intramedullary Rods \(Withdrawn 1996\)](#)³

[F565 Practice for Care and Handling of Orthopedic Implants and Instruments](#)

[F1611 Specification for Intramedullary Reamers](#)

[F2503 Practice for Marking Medical Devices and Other Items for Safety in the Magnetic Resonance Environment](#)

[F2809 Terminology Relating to Medical and Surgical Materials and Devices](#)

¹ This specification is under the jurisdiction of ASTM Committee F04 on Medical and Surgical Materials and Devices and is the direct responsibility of Subcommittee F04.21 on Osteosynthesis.

Current edition approved May 1, 2016. Published June 2016. Originally approved in 1989. Last previous edition approved in 2014 as F1264 – 14. DOI: 10.1520/F1264-16E01.

² For referenced ASTM standards, visit the ASTM website, www.astm.org, or contact ASTM Customer Service at service@astm.org. For *Annual Book of ASTM Standards* volume information, refer to the standard's Document Summary page on the ASTM website.

³ The last approved version of this historical standard is referenced on www.astm.org.

2.2 AMS Standard:

AMS 5050 Steel Tubing, Seamless, 0.15 Carbon, Maximum Annealed⁴

2.3 SAE Standard:

SAE J524 Seamless Low-Carbon Steel Tubing Annealed for Bending and Flaring⁴

3. Terminology

3.1 Definitions for Geometric:

3.1.1 *closed section, n*—any cross section perpendicular to the longitudinal axis of a solid or hollow IMFD in which there is no discontinuity of the outer wall.

3.1.1.1 *Discussion*—To orient the IMFD for testing and for insertion, the desired relationship of any irregularities, asymmetries, and so forth, to the sagittal and coronal planes for the intended applications should be described.

3.1.2 *IMFD curvature, n*—dimensions of size and locations of arcs of the curvature, or mathematical description of the curvature, or other quantitative descriptions to which the curvature is manufactured along with tolerances.

3.1.2.1 *Discussion*—To orient the IMFD for testing and for insertion, the desired relationship of the curvature to the sagittal and coronal planes for the intended applications should be described.

3.1.3 *IMFD diameter, n*—diameter of the circumscribed circle that envelops the IMFD's cross section when measured along its working length. If the diameter is not constant along the working length, then the site of measurement should be indicated.

3.1.4 *IMFD length, n*—length of a straight line between the most proximal and distal ends of the IMFD.

3.1.5 *open section, n*—any cross section perpendicular to the longitudinal axis of a hollow IMFD in which there is a discontinuity of the outer wall.

3.1.5.1 *Discussion*—To orient the IMFD for testing and insertion, the desired relationship of the discontinuity to the sagittal and coronal planes for the intended applications should be described.

3.1.6 *potential critical stress concentrator (CSC), n*—any change in section modulus, material property, discontinuity, or other feature of a design expected to cause a concentration of stress in a region of the IMFD expected to be highly stressed under the normal anticipated loading conditions.

3.1.7 *tolerance, n*—acceptable deviations from the nominal size of any dimension describing the IMFD.

3.1.8 *working length, n*—length of uniform cross section of the IMFD intended to obtain some type of fit to the medullary canal in the area of the diaphysis.

3.2 Definitions—Mechanical/Structural:

3.2.1 *bending compliance, n*—reciprocal of the stiffness of the IMFD under a bending load in a specified plane as defined and determined in the static four-point bend test described in **Annex A1**.

3.2.2 *failure strength, n*—the force parameter (for example, load, moment, torque, stress, and so forth) required to meet the

failure criteria, as defined and measured according to the test conducted. (See **Note 1**.)

NOTE 1—No present testing standard exists related to this term for IMFDs.

3.2.3 *fatigue strength at N cycles, n*—the maximum cyclic force parameter (for example, load, moment, torque, stress, and so forth) for a given load ratio, which produces device structural damage or meets some other failure criterion in no less than *N* cycles as defined and measured according to the test conducted.

3.2.4 *N*—a variable representing a specified number of cycles.

3.2.5 *no load motion*—relative motion between the IMFD and the bone that occurs with no elastic strain in the device and no (or minimal) change in load. (See **Note 1**.)

3.2.6 *structural stiffness, n*—the maximum slope of the elastic portion of the load-displacement curve as defined and measured according to the test conducted.

3.2.6.1 *Discussion*—For bending in a specified plane, this term is defined and determined in the static four-point bend test described in **Annex A1**.

3.2.7 *ultimate strength, n*—maximum force parameter (for example, load, moment, torque, stress, and so forth) which the structure can support, defined and measured according to the test conducted.

3.2.8 *yield strength, n*—the force parameter (for example, load, moment, torque, stress, and so forth) which initiates permanent deformation as defined and measured according to the test conducted.

4. Classification

4.1 The following IMFDs may be used singly, multiply, and with or without attached supplemental fixation: solid cross section, hollow cross section (open, closed, or a combination).

4.2 Intended application or use for particular IMFD designs:

4.2.1 *Preferred Orientation:*

4.2.1.1 Right versus left,

4.2.1.2 Sagittal versus coronal plane,

4.2.1.3 Proximal versus distal, and

4.2.1.4 Universal or multiple options.

4.2.2 *Preferred Anatomic Location:*

4.2.2.1 Specific bone,

4.2.2.2 Proximal versus distal versus midshaft, and

4.2.2.3 Universal or multiple options.

4.2.3 *Preferred Use Limited to Specific Procedures:*

4.2.3.1 Acute care of fractures,

(1) Specific types,

(2) Specific locations,

4.2.3.2 Reconstructive procedures, and

4.2.3.3 Universal or multiple options.

5. Material

5.1 All IMFDs made of materials that have an ASTM standard shall meet those requirements given in the ASTM standard (2.1).

⁴ Available from Society of Automotive Engineers (SAE), 400 Commonwealth Dr., Warrendale, PA 15096-0001, <http://www.sae.org>.

6. Performance Considerations and Test Methods

6.1 *Cross Section Dimensional Tolerances* affect matching the bone preparation instruments (that is, reamers) to the IMFD diameter, and the IMFD in the bone.

6.1.1 Terminology related to sizing of IMFD devices and instruments is provided in Specification F1611.

6.2 *Longitudinal Contour Tolerances* (along with bending compliance) affect the fit and fixation of IMFDs in the bone.⁴

6.3 *Fatigue Strength* affects the choice of implant in cases in which delayed healing is anticipated (that is, infected nonunions, allografts, segmental loss, multiple trauma, and so forth).

6.3.1 The fatigue strength or fatigue lives or both for IMFDs subjected to cycle bending forces shall be determined using the cyclic bending fatigue test method in Annex A3.

6.3.2 The fatigue strength or fatigue lives or both for IMFD locking screws subjected to cyclic bending forces shall be determined using the cyclic bending fatigue test method for locking screws in Annex A4.

6.4 *Bending Strength* affects the choice of implant in which load sharing is minimized or loading is severe or both (that is, with distal or proximal locking, subtrochanteric fractures, comminuted fracture, segmental loss, noncompliant patient, and so forth).

6.4.1 Yield, failure, and ultimate strength for IMFDs subjected to bending in a single plane shall be determined using the static four-point bend test method described in Annex A1.

6.5 *Bending and Torsional Stiffness* may affect the type and rate of primary or secondary healing, depending upon the fracture type (transverse, oblique, and so forth).

6.5.1 Bending structural stiffness for IMFDs subjected to bending in a single plane shall be determined using the static four-point bend test method described in Annex A1.

6.5.2 Torsional stiffness for IMFDs subjected to pure torsion shall be determined using the static torsion test method described in Annex A2.

6.6 *No-Load Axial and Torsional Motion Allowed in Devices Using Secondary Attached Fixation* affects degree of motion at the fracture site. (See Note 1.)

6.7 *Extraction System*—Mechanical failures should occur in the extraction device before they occur in the IMFD. This prevents the need to remove the IMFD without proper tools. (See Note 1.)

7. Marking, Packaging, Labeling, and Handling

7.1 Dimensions of IMFDs should be designated by the standard definitions given in 3.1.

7.2 IMFDs should be marked using a method in accordance with Practice F86.

7.3 Use the markings on the IMFD to identify the manufacturer or distributor. Mark away from the most highly stressed areas where possible.

7.4 Packaging shall be adequate to protect the IMFD during shipment.

7.5 The following shall be included on package labeling for IMFDs:

- 7.5.1 Manufacturer and product name,
- 7.5.2 Catalog number,
- 7.5.3 Lot or serial number,
- 7.5.4 IMFD diameter (3.1.3), and
- 7.5.5 IMFD length (3.1.4).

7.6 IMFDs should be cared for and handled in accordance with Practice F565.

7.7 See Practice F2503 to identify potential hazards produced by interactions between the device and the MR environment and for terms that may be used to label the device for safety in the MR environment.

8. Means for Insertion and Extraction

8.1 For IMFDs that are to be extracted using a hook device, the following requirements apply:

8.1.1 The slot at the end of the IMFD shall have the dimensions shown in Fig. 1.

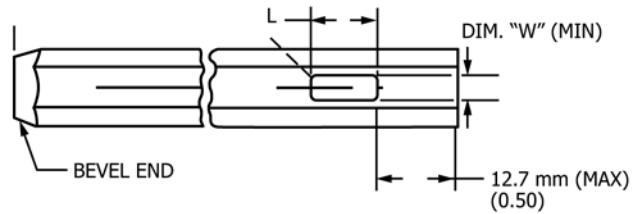

IMFD Diameter, mm	Hook Size	Slot Length, L, mm	Slot Width, W, mm
6, 7	2	9.53	1.91
8 and larger	1	9.53	3.23

FIG. 1 Dimensions of Extractor Hook Slot

8.1.2 The hook used for extraction shall have the dimensions shown in Fig. 2.

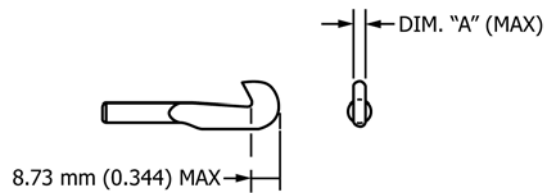

Hook Size	Hook Width, A, mm
1	3.05
2	1.78

FIG. 2 Dimensions of Extractor Hook

9. Keywords

9.1 bend testing; definitions; extraction; fatigue test; fracture fixation; implants; intramedullary fixation devices; orthopaedic medical device; performance; surgical devices; terminology; test methods; torsion test; trauma

ANNEXES

(Mandatory Information)

A1. TEST METHOD FOR STATIC FOUR-POINT BEND TEST

A1.1. Scope

A1.1.1 This test method describes methods for static four-point bend testing of intrinsic, structural properties of intramedullary fixation devices (IMFDs) for surgical fixation of the skeletal system. This test method includes bend testing in a variety of planes relative to the major anatomic planes. The purpose is to measure bending strength and bending stiffness intrinsic to the design and materials of IMFDs.

A1.1.2 This test method is designed specifically to test IMFD designs that have a well defined working length (WL) of uniform open or closed cross section throughout the majority of its length ($WL \geq 10 \times$ diameter) and shall be applied to the full length of the diaphysis of a femur, tibia, humerus, radius, or ulna. This is not applicable to IMFDs that are used to fix only a short portion of the diaphysis of any of the long bones or the diaphysis of small bones such as the metacarpals, metatarsals, phalanges, and so forth.

A1.1.3 This test method is not intended to test the extrinsic properties (that is, the interaction of the device with bone or other biologic materials), of any IMFD.

A1.1.4 This test method is not intended to define case-specific clinical performance of these devices, as insufficient knowledge to predict the consequences of the use of any of these devices in individual patients is available.

A1.1.5 This test method is not intended to serve as a quality assurance document, and thus, statistical sampling techniques for batches from production of IMFDs are not addressed.

A1.1.6 This test method may not be appropriate for all types of implant applications. The user is cautioned to consider the appropriateness of the method in view of the devices being tested, the material of their manufacture, and their potential applications.

A1.1.7 This test method is intended to evaluate the bending strength or bending stiffness of the working length of the IMFD, and may not be appropriate for all situations. When the structurally critical region of the IMFD is shown to be located at the proximal or distal extremity of the IMFD, it may be necessary to evaluate the bending strength or bending stiffness of this region of the IMFD using a different test method. This is because it may not be physically possible to fit the proximal or distal extremity between the inner rollers of a four-point bend test. Structurally critical regions may be identified through such methods as hand calculations, finite element analysis, etc. Screw holes or other interlocking features are typically located at the proximal and distal extremities of an IMFD, and may result in structurally critical regions at these locations.

A1.1.8 The values stated in SI units are to be regarded as standard. No other units of measurement are included in this standard.

A1.1.9 *This standard does not purport to address all of the safety concerns, if any, associated with its use. It is the responsibility of the user of this standard to establish appropriate safety and health practices and determine the applicability of regulatory limitations prior to use.*

A1.2. Terminology

A1.2.1 Definitions:

A1.2.1.1 *bending compliance, n* —reciprocal of the stiffness of the IMFD under a bending load in a specified plane ($1/EI_e$ for the IMFD, y/F for the system tested).

A1.2.1.2 *bending moment, n* —moment required to meet predetermined failure criteria.

A1.2.1.2.1 *Discussion*—Failure may be defined as permanent deformation, breakage, or buckling.

A1.2.1.3 *bending moment to yield, n* —moment which produces plastic deformation as defined by the 0.2 % strain offset method from the load-displacement curve.

A1.2.1.4 *bending structural stiffness, n* —resistance to bending of an IMFD, normalized to the cross-sectional properties of the working length without regard to the length of IMFD tested, by the calculations described in A1.5.1.8 (the effective EI_e for the region tested).

A1.2.1.5 *fixture/device compliance, n* —measurement of the combined compliance of the IMFD on the test fixture with co-aligned load-support points (such as A1.7.2). This value is dependent upon IMFD orientation, load direction, and load and support spans.

A1.2.1.6 *ultimate bending moment, n* —moment at the maximum or ultimate load as measured on the load-displacement curve for any test in accordance with A1.6.1.

A1.2.2 Definitions of Terms Specific to This Standard:

A1.2.2.1 The testing mode shall consist of an applied compression load cycle, at a constant displacement rate, to a defined failure.

A1.2.2.2 The testing mode shall be single cycle with the load applied at least three diameters of the IMFD from the nearest critical stress concentration point (CSC) unless otherwise specified or unless the CSC is a characteristic of the normal cross section in the working length.

A1.3 Classification

A1.3.1 Types of Test Covered by This Specification Are:

A1.3.1.1 Measurement of structural mechanical behavior inherent to IMFDs—intrinsic properties.

A1.3.1.2 Measurement of single-cycle elastic stiffness and strength in four-point bending.

A1.3.1.3 Measurement of a single-cycle fixture/device elastic compliance.

A1.4. Significance and Use

A1.4.1 This test method describes a static bending test to determine the bending stiffness and bending strength of the central and uniform portions of an IMFD.

A1.4.2 This test method may not be appropriate for all types of implant applications (that is, in proximal or distal extremity of an IMFD where screw holes exist). The user is cautioned to consider the appropriateness of the method in view of the devices being tested and their potential applications.

A1.5. Procedure

A1.5.1 *Bending Test for Intrinsic Properties of the Working Length (WL):*

A1.5.1.1 Determine the spans to be used as described in A1.5.1.2 and A1.5.1.3 and set the spans, *s*, *c*, and *L* to within 1 % of the determined values.

A1.5.1.2 Conduct the four-point bending test at room atmospheric conditions as shown in Fig. A1.1, using two rolling supports spaced from 10 to 50 cm apart, *L*, with the span between the loading points, *c*, no greater than *L*/3. The loading points should also be of the rolling type, and the diameter of both the loading and support rollers should be between 1.0 and 2.6 cm. The choice of spans should be made based upon the guidelines given in A1.7.2.

A1.5.1.3 A recommendation for load and support spans is provided below to minimize interlaboratory variability and provide consistency with the previous ASTM standard for four-point bend testing of IMFDs. The suggested long or short span should be used whenever possible, provided the general guidelines of A1.7.2 are achieved. The short span is identical to that used in the previous standard, Practice F383, and the long span is based upon the experience of several laboratories testing a broad range of designs and sizes of current (1995) IMFD designs.

Short span	<i>s</i> = <i>c</i> = 38 mm	<i>L</i> = 114 mm
Long span	<i>s</i> = <i>c</i> = 76 mm	<i>L</i> = 228 mm

A1.5.1.4 Apply equal loads at each of the loading points (a single load centered over the load points as shown in Figs. A1.1 and A1.2 is the usual method) at a constant rate of displacement no greater than 1 mm/s. Measure the relative deflections between the support and loading points (inner versus outer), *y*. For devices made of strain-rate-sensitive materials, the displacement rate for a given strain rate may be estimated by using the following approximations:

$$y_{1\%} = S_{t\ 1\%} \cdot c \text{ and } c = L - 2s \tag{A1.1}$$

$$y_{1\%} = s(L + 2c) / (300 D_{IMFD}) \tag{A1.2}$$

$$= s(3L - 4s) / (300 D_{IMFD})$$

or

$$= s(3c + 2s) / (300 D_{IMFD})$$

where:

- S_t* = the desired strain rate,
- y_{1%}* = the deflection at the loading point for an estimated 1 % maximum strain in the IMFD,
- s* = the span from a load point to the nearest support,
- c* = the center span,
- L* = the total span (*c* + 2*s*), and
- D_{IMFD}* = the diameter of the IMFD.

NOTE A1.1—The deflection rate that corresponds to the desired strain rate is only a rough estimate based upon the assumptions of plane strain for closed-section tubes or solid rods so that the neutral axis of the cross section lies uniformly throughout the working length in the center of the circumscribed circle of the cross section and there is material in the cross section touching the circumscribed circle where it intersects the plane of bending.

A1.5.1.5 Compute the bending moment, *M*, as used in A1.2.1 as follows:

$$M = Fs/2 \tag{A1.3}$$

where:

- F* = the force applied to the system (two times the force applied to each of the loading points) and
- s* = the span from a load point to the nearest support.

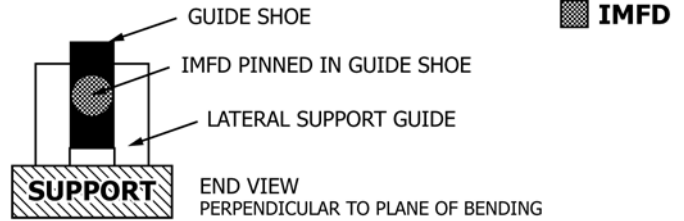
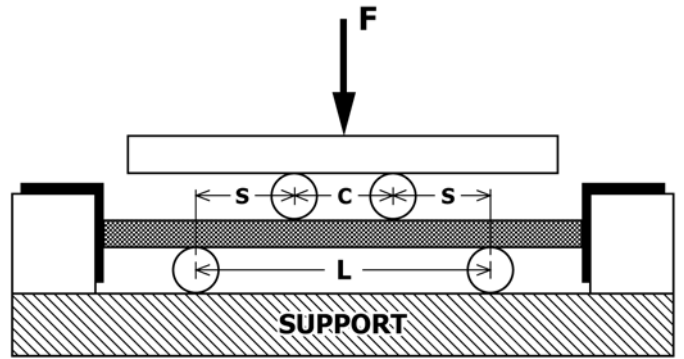
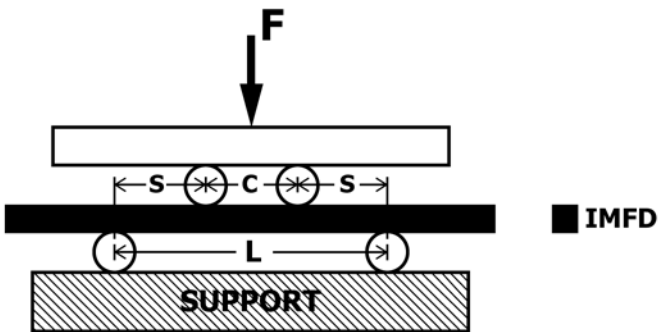

FIG. A1.2 Four-Point Bend Test with Guide Shoes



RANGE OF SPANS, in mm
L = 100 -> 500
s = 33 -> 250
c = 0 -> 167

FIG. A1.1 Four-Point Bend Test Setup

A1.5.1.6 Compute an estimate for the maximum strain in the IMFD as follows:

$$S_{MAX} = FS D_{IMFD} (4 EI_e)^{-1} \quad (A1.4)$$

$$y = Fs^2 (L + 2c) (12 EI_e)^{-1} \quad (A1.5)$$

where:

- S_{MAX} = estimate of maximum strain in the IMFD,
- F = force on the system,
- s = span from a load point to the nearest support point,
- EI_e = effective structural stiffness of the IMFD portion tested,
- D_{IMFD} = diameter of the IMFD,
- L = the total span between supports ($2s + c$), and
- c = the center span.

A1.5.1.7 Compute the bending moment to yield by estimating the load at 0.2 % maximum plastic strain. This can be approximated by calculating as follows:

$$y_{0.2\%} = s(L + 2c)/(1500 D_{IMFD}) \quad (A1.6)$$

where:

- $y_{0.2\%}$ = the permanent deflection at the loading point for 0.2 % maximum plastic strain (estimated by measuring the offset displacement from the linear region of the load-displacement curve),
- s = the span from a load point to the nearest support,
- c = the center span,
- L = the total span ($c + 2s$), and
- D_{IMFD} = the diameter of the IMFD.

At this point on the load-deflection curve, read the yield force, F_y . From F_y the bending moment to yield is computed from:

$$M_y = F_y s/2 \text{ (see Fig. A1.3)} \quad (A1.7)$$

Likewise, the ultimate bending moment, M_{MAX} , may be determined from the load-deflection curve as follows:

$$M_{MAX} = F_{MAX} s/2 \text{ (see Fig. A1.3)} \quad (A1.8)$$

NOTE A1.2—The estimate of the deflection that corresponds to the 0.2 % desired strain is only a rough estimate based upon the assumptions of plane strain for closed section tubes or solid rods so that the neutral axis of the cross section lies uniformly throughout the working length in the center of the circumscribed circle of the cross section and that there is material in the cross section touching the circumscribed circle where it intersects the plane of bending.

A1.5.1.8 Compute the bending structural stiffness, EI_e , as follows:

$$EI_e = s^2(L + 2c)(F/y)/12 \quad (A1.9)$$

or

$$EI_e = s^2(3L - 4s)(F/y)/12 \quad (A1.10)$$

where:

- F/y = the slope of the elastic portion of the load-displacement curve,
- s = the span from a load point to the nearest support,
- c = the center span, and
- L = the total span ($c + 2s$).

NOTE A1.3—If no linear range can be easily approximated from the load-displacement curve, the ratio of the bending load to yield to the total deflection produced by that load at the loading point can be used to estimate the average slope of the elastic range of bending.

A1.5.1.9 Bending should be applied in the planes of maximum (I_{max}) and minimum (I_{min}) area moments of inertia of the working length cross section, and the orientation of the principal inertia axes relative to the medial-lateral (ML) and anterior-posterior (AP) anatomic planes should be reported. If the working length of the IMFD does not have a uniform cross section, or is twisted such that the orientation of the principal inertial axes are not constant along its length, then the IMFD should be loaded to the ML and AP anatomic planes, with the IMFD oriented relative to the anatomic planes as for its intended clinical application.

A1.5.1.10 For IMFDs that have rotational instability for any given bending mode, the ends should be gripped by the fixtures shown in Fig. A1.2. This fixture will allow the IMFD to be constrained outside the actively loaded region by plates that prevent rotation of the IMFD while allowing in-plane bending with supported, free ends in such a manner that the ends are stable when the IMFD rests on the outer support rollers. The use of guide shoes will produce a mixed loading condition as a result of friction in the portion of the system that resists rotation and this will contribute to the bending resistance. The magnitude of this effect is not easily measured or estimated but should be noted in the report.

A1.5.2 Fixture/Device Compliance Test for the Intrinsic Properties of the Working Length:

A1.5.2.1 Align both of the supports directly in line with the load points (see Fig. A1.4).

A1.5.2.2 Place the working length of the IMFD between the load point and support. Orient the IMFD so that the load is applied in the desired plane (AP , ML , or another specified direction).

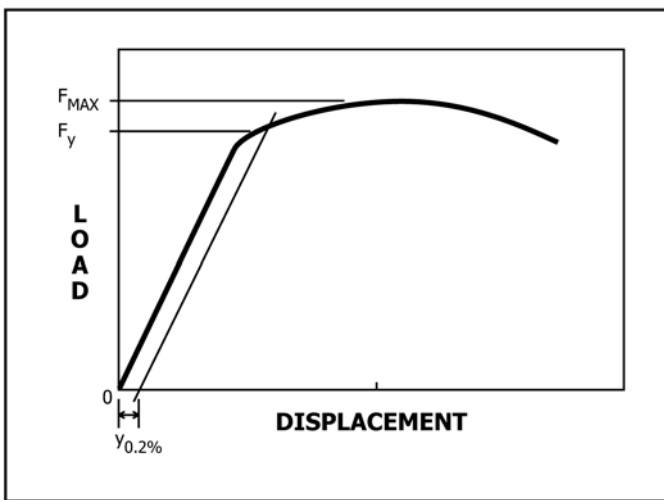

NOTE 1—An estimate of a 0.2 % yield point can be made from the “load cell versus ram displacement” measurements. Load represents the total load on the system ($2\times$ the load at each support) and the displacement represents the deflection at the load point(s) relative to the supports in the y (or vertical) direction. Setting $S_{MAX} = 0.002$ in the strain estimate equation (A1.5.1.6) and substituting into y gives:

$$y_{0.2\%} = 2 s (L + 2c) (3D_{IMFD})^{-1} \times 10^{-3}$$

where: $y_{0.2\%}$ = an estimate of the deflection at the load point which corresponds to 0.2 % strain.

FIG. A1.3 Load Cell Versus Ram Displacement Graph

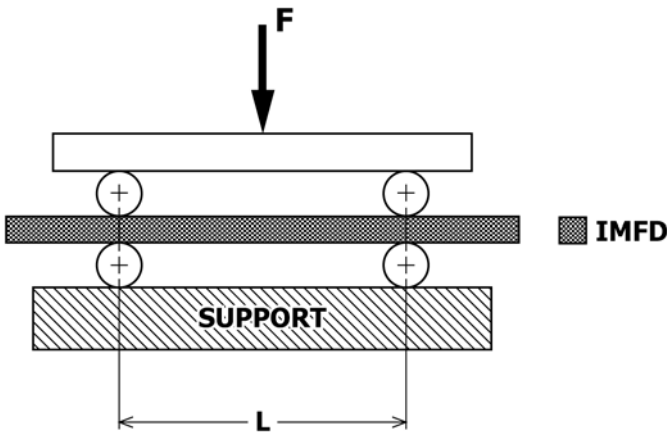

FIG. A1.4 Fixture/Device Compliance Test Setup

A1.5.2.3 Load the IMFD in compression at a constant displacement rate of 0.1 mm/s. Record the slope of the load-displacement curve.

A1.5.2.4 Calculate the fixture/device compliance by calculating the reciprocal of the slope of the load-displacement curve in the elastic region and express in mm/N.

A1.6 Number of Specimens

A1.6.1 At least three specimens shall be tested for each sample of IMFD of uniform working length within the test span of the same design, size, material, and so forth tested.

A1.7 Apparatus

A1.7.1 Machines used for the bending tests should conform to the requirements of Practices E4.

A1.7.2 The purpose of allowing a variety of spans and roller diameters for the bending tests is to allow one to accommodate the design differences of devices while maintaining standard techniques. For hollow and open-section IMFDs, long spans and large-diameter rollers will minimize local artifacts at the load and support points as much as possible. For long, small-diameter, solid section IMFDs, much smaller rollers and smaller spans are adequate to measure the bending of the IMFD (see A1.5.1.2).

A1.8. Precision and Bias

A1.8.1 Minimizing and Correcting for Test Errors:

A1.8.1.1 Because of differences in cross-sectional shapes, areas, working lengths, and so forth, sensitivity to potential sources of measurement error will be different for each device. Typical sources of error include: (1) span measurements, (2) compliance of the IMFD at the support, (3) fixture compliance, and (4) shear load produced at the load and support points in proportion to bending produced.

A1.8.1.2 *Span Measurement*—In general, longer spans minimize the effect of measurement error. However, the effect of particular measurement errors can be minimized by proper selection of the support and load spans. For example, calculated structural stiffness, EI_e , is more sensitive to errors in measurement of load-to-support point distance, s , than in the center span, c , because stiffness is dependent on s^2 and only

linearly dependent on c . Therefore, maximizing s and minimizing c within the guidelines of A1.6.1 will reduce stiffness measurement errors.

A1.8.1.3 *Shear Load Errors*—Test Methods D790 recommends a 16:1 support span-to-depth (such as, specimen thickness) ratio to minimize the effects of shear and compressive loads at the load and support points on the structural bending strength. This ratio should be used within the guidelines of A1.5.1.2, unless the device has insufficient working length to provide such spans.

A1.8.1.4 *Compensating for Fixture/Device Compliance*—Fixture/device compliance can be measured by setting the supports and load points coincident (so that $s = 0$, $c = L$ as described in A1.5.2). An elastic measure in this setup gives the combined device/fixture compliance, y/F_{F+D} . By subtracting this measurement from the system compliance measurements, y/F_{SYS} , during the bending tests, one is left with the bending compliance, y/F_{BEND} .

$$y/F_{BEND} = y/F_{SYS} - y/F_{F+D} \quad (A1.11)$$

The reciprocal of the bending compliance is the bending stiffness for the setup, which should be used in A1.5.1 to compute the structural bending stiffness of the IMFD, EI_e . By using this technique of compensating for the effect of local compliance, shear loading, and fixture compliance, it is possible to keep these artifacts within reasonable limits for support span-to-IMFD diameter ratios of less than 20. This helps to ensure that the bending test, in fact, measures bending. Note that the fixture/device and fixture compliances may not be linear for all load ranges; thus, these measurements should be carried out within the load ranges used for IMFD testing.

A1.8.1.5 *Toe Region Compensation*—Toe region compensation may be necessary to determine system, device, or fixture compliance/stiffness measurements. If a toe region exists, or if a true linear region cannot be identified, compliance/stiffness measures can be estimated by use of standard techniques such as in Test Methods D790, Appendix X1, Toe Compensation.

A1.8.2 Tables A1.1-A1.4 provide the precision statistics for the following test parameters: load-displacement slope, bending structural stiffness, bending moment to yield, and ultimate bending moment, respectively. These results are based on a round robin interlaboratory study (ILS) conducted during the Fall of 1997 in accordance with Practice E691. The precision statistics were determined using the Practice E691 software (Version 2).

A1.8.3 In the ILS, specimens from three types of cylindrical steel tubes were used with the characteristics described in

TABLE A1.1 Precision Statistics for Load-Displacement Slope, F/y

Specimen Group	Mean (N/mm)	S_r^A	S_R^B	r^C	R^D	No. of Labs
A	905.23	9.03	28.15	25.28	78.81	8
B	1667.63	59.11	127.34	165.51	356.56	8
C	132.20	4.02	11.18	11.26	31.32	8

^A S_r = intralaboratory standard deviation of the mean.

^B S_R = interlaboratories standard deviation of the mean.

^C r = 2.83 S_r .

^D R = 2.83 S_R .

TABLE A1.2 Precision Statistics for Bending Structural Stiffness, EI_e

Specimen Group	Mean (N/m ²)	S_r^A	S_R^B	r^C	R^D	No. of Labs
A	179.59	2.16	7.82	6.04	21.89	6
B	396.49	17.56	41.47	49.16	116.13	6
C	25.30	0.73	1.05	2.04	2.95	6

^A S_r = intralaboratory standard deviation of the mean.

^B S_R = interlaboratories standard deviation of the mean.

^C r = 2.83 S_r .

^D R = 2.83 S_R .

TABLE A1.3 Precision Statistics for Bending Moment to Yield, M_y

Specimen Group	Mean (N-m)	S_r^A	S_R^B	r^C	R^D	No. of Labs
A	183.47	3.26	12.78	9.12	35.77	8
B	79.13	1.44	6.85	4.02	19.19	8
C	11.03	0.30	0.58	0.83	1.62	8

^A S_r = intralaboratory standard deviation of the mean.

^B S_R = interlaboratories standard deviation of the mean.

^C r = 2.83 S_r .

^D R = 2.83 S_R .

TABLE A1.4 Precision Statistics for Ultimate Bending Moment, M_{MAX}

Specimen Group	Mean (N-m)	S_r^A	S_R^B	r^C	R^D	No. of Labs
A	237.22	1.75	2.77	4.90	7.76	7
B	107.15	1.44	4.15	4.04	11.61	7
C	12.75	0.18	0.27	0.49	0.75	7

^A S_r = intralaboratory standard deviation of the mean.

^B S_R = interlaboratories standard deviation of the mean.

^C r = 2.83 S_r .

^D R = 2.83 S_R .

Table A1.5. The strength, stiffness, and geometry of the three specimen groups were intended to represent the range of likely values for IMFDs. For each specimen group, the samples were cut from a single length of bar stock.

A1.8.4 A total of eight laboratories participated in the testing. Three samples from specimen Group A were typically tested by each laboratory, and five samples from specimen Groups B and C were typically tested. To have a balanced statistical study and meet the requirements of the Practice E691 software, four replicates were used for the statistical analysis. If only two or three specimen results were available from a particular laboratory, then the average from that laboratory was used to make up for the missing data points. Likewise, if five specimen results were available from a particular lab, then the farthest outlying result was discarded. Labs were only included

if they provided results for all three specimen groups. For the four parameters investigated, a minimum of six labs were included, satisfying the Practice E691 requirements.

A1.8.5 *Repeatability, r*—In comparing two test results for the same material, obtained by the same operator using the same equipment on the same day, the two test results should be judged not equivalent if they differ by more than the r value for that material.

A1.8.6 *Reproducibility, R*—In comparing two test results for the same material, obtained by different operators using different equipment on different days, the two test results should be judged not equivalent if they differ by more than the R value for that material.

NOTE A1.4—The explanations for r and R (A1.8.5 and A1.8.6) are only intended to present a meaningful way of considering the approximate precision of this test method. The data in Tables A1.1-A1.4 should not be applied rigorously to acceptance or rejection of a material, as those data are specific to the round robin and may not be representative of other lots, materials, or laboratories. Users of this test method should apply the principles outlined in Practice E691 to generate data specific to their laboratory and materials.

A1.8.7 Any judgment in accordance with A1.8.5 and A1.8.6 should have at least an approximate 95 % (0.95) probability of being correct.

A1.8.8 *Bias*—No statement may be made about bias of these test methods since there is no standard reference device or material that is applicable.

A1.9 Report

A1.9.1 *Purpose*—Reports of results should be aimed at providing as much relevant information as necessary for other investigators, designers or manufacturers to be able to duplicate the tests being reported. Thus the choices for all relevant parameters from the methods shall be reported. Other relevant observations that influence the interpretation of results such as distortion of cross section, localized buckling at support points, cracks at stress concentration points, and so forth should also be reported. Criteria for failure and observed modes of failure should also be reported.

A1.9.2 *Report*—Report the following information:

A1.9.2.1 Complete identification of the device(s) tested including type, manufacturer, catalogue number(s), lot number(s), material specifications, principal dimensions (and precision of measurements of those dimensions), and previous history (if applicable).

A1.9.2.2 Direction and location of the loading of the specimens.

TABLE A1.5 Description of Specimen Groups in ILS

Specimen Group	Outer Diameter, in.	Inner Diameter, in.	Material	Material Yield Strength ksi	Material Tensile Strength ksi	Material Elongation, %
A	0.472 ± 0.003	0.199 ± 0.002	316LVM stainless steel (Specification F138, Grade 2)	100 min	125 min	12 min
B	0.625 ± 0.004 (Specification A450/A450M)	0.495 (Specification A450/A450M)	carbon steel (Specification A214/A214M)	39.5	51.6	51
C	0.313 (SAE J524)	0.243 (SAE J524)	carbon steel (AMS 5050)	36.1	54.2	40

A1.9.2.3 Conditioning procedure, if any.

A1.9.2.4 Total support span, L ; load to support span, s ; and precision of each measurement made.

A1.9.2.5 Fixture/device compliance measured in mm/N.

A1.9.2.6 Support span-to-depth ratio and methods of compensation chosen for small ratios or radially compliant devices or both.

A1.9.2.7 Use of outriggers or supports for control of rotation during testing.

A1.9.2.8 Methods to compensate for toe regions or compensation for any other phenomena encountered (see Test Methods D790).

A1.9.2.9 Radius of supports and loading roller and precision of those measurements.

A1.9.2.10 Rate of crosshead motion.

A1.9.2.11 Slope of the linear portion of the load-displacement curve, F/y , in N/mm; estimate of structural stiffness of the IMFD, EI_e , in N-m², from F/y , s , c and L ; and an explanation of adjustments for fixture/device compliance.

A1.9.2.12 Load at yield, F , in N and the estimate of moment at yield, M_y , in N-m; and any other failure criteria/measures made.

A1.9.3 *Statistical Report:*

A1.9.3.1 The mean value, number of specimens in the sample and the sample deviations should be reported for each measurement and calculation of values so that the precision and accuracy of the test method as well as the behavior of the specific IMFD design and size can be established.

A1.9.3.2 The report shall include the results and methods of tests used to determine outliers and normality of the data.

A1.10 Rationale (Nonmandatory Information)

A1.10.1 IMFDs are bone fracture fixation devices intended for use as temporary, adjunctive stabilizing devices for skeletal parts with a limited mechanical service life only until the injured hard or soft tissue parts or both have healed. These devices are not designed to support the skeletal parts indefinitely if the injured parts do not heal. This is far different from prosthetic devices that are intended to replace the mechanical function of a skeletal or soft tissue part permanently and serve as the sole load-bearing member.

A1.10.2 The bending stiffness of IMFDs throughout the working length is known to have an effect upon the level of load transfer and level of stress in the surrounding bone and callus and to influence the rate and strength of healing of the bone as well as long-term remodeling. The specific level of stress and load in the bone related to a specific bending stiffness is unknown and dependent upon multiple factors such as level and type of activity of the patient, condition of the surrounding bone and soft tissue, stability of the fracture pattern and its fixation, size of the bone, weight of the patient, and so forth. Thus, measurements of structural bending stiffness using this standard testing technique are only of value for comparative purposes between devices of different sizes, designs, and materials.

A1.10.3 The single-cycle bending strength of IMFDs is known to be an important factor in cases in which bone support is minimal and a secondary trauma occurs. In such cases, a plastic deformation (load beyond the yield moment) may occur, necessitating a secondary surgical procedure for correction of any anatomic deformity that is clinically unacceptable. Since secondary trauma is uncontrollable and unpredictable, there is no acceptable limit that can be set for bending strength in any plane. Thus, measurements of structural bending strength using this standard testing technique are only of value for comparative purposes between devices of different sizes, designs, and materials. The separation between the bending moment to yield and the ultimate bending moment reflects the ductility of a given design. This may be important in cases in which a single event of secondary trauma has created plastic deformity in the IMFD which requires reverse bending beyond yield to straighten the IMFD sufficiently for removal. An IMFD with minimal ductility is at increased risk of breaking instead of bending during either secondary trauma or an intraoperative correction maneuver may result in greater risk to some patients.

A1.10.4 Recommended load and support spans are based upon consistency with the old Practice F383 for short spans, laboratory experiences with larger hollow femoral devices for the long spans, and reflects common practice.

A2. TEST METHOD FOR STATIC TORSIONAL TESTING OF INTRAMEDULLARY FIXATION DEVICES

A2.1. Scope

A2.1.1 This test method covers the test procedure for determining the torsional stiffness of intramedullary fixation devices (IMFDs). The central part of the IMFD, with a straight

and uniform cross-section and away from screw holes or other interlocking features, is tested in a static test.

A2.1.2 IMFDs are indicated for surgical fixation of the skeletal system and are typically used in the femur, tibia,

humerus, radius, or ulna. Devices that meet the IMFD specifications of Section 4, and other similar devices, are covered by this test method.

A2.1.3 This test method does not intend to test or provide information that will necessarily relate to the properties of fixation that an IMFD may achieve in a bone or any other connection with other devices.

A2.1.4 This test method is not intended to define case-specific clinical performance of these devices, as insufficient knowledge to predict the consequences of the use of any of these devices in individual patients is available.

A2.1.5 This test method is not intended to serve as a quality assurance document. Thus, statistical sampling techniques for batches from the production of IMFDs are not addressed.

A2.1.6 The values stated in SI units are to be regarded as standard. No other units of measurement are included in this standard.

A2.1.7 This test method is intended to evaluate the torsional stiffness of the working length of the IMFD, and may not be appropriate for all situations. When the structurally critical region of the IMFD is shown to be located at the proximal or distal extremities of the IMFD, it may be appropriate to evaluate the torsional stiffness of the IMFD using a different test method. Structurally critical regions may be identified through such methods as hand calculations, finite element analysis, etc. Screw holes or other interlocking features are typically located at the proximal and distal extremities of an IMFD, and may result in structurally critical regions at these locations. It may also be appropriate to use a different test method if the torsional stiffness of the working length of the IMFD is shown to not be the critical design feature.

A2.1.8 *This standard does not purport to address all of the safety concerns, if any, associated with its use. It is the responsibility of the user of this standard to establish appropriate safety and health practices and determine the applicability of regulatory limitations prior to use.*

A2.2. Summary of Test Method

A2.2.1 An intramedullary fixation device is secured in a fixture so that a straight, uniform cross section of specified length is in the gage section. The IMFD is loaded under a pure torsional moment and the resulting angular deflection (rotation) is measured. The slope of the torque-rotation curve provides the elastic torsional stiffness of the IMFD.

A2.3 Terminology

A2.3.1 *Definition of Term Specific to This Standard:*

A2.3.1.1 *torsional stiffness, n* —the slope of the torque-rotation curve in N-m/° as determined in A2.8.1.

A2.4. Significance and Use

A2.4.1 This test method describes a static torsional test to determine the torsional stiffness of the central and uniform portion of an intramedullary fixation device.

A2.4.2 This test method may not be appropriate for all types of implant applications. The user is cautioned to consider the

appropriateness of the method in view of the devices being tested and their potential application.

A2.5. Apparatus

A2.5.1 *Torsional Load Frame*, a testing machine capable of applying torsional loads at a constant angular displacement rate and capable of either applying axial loads in load control or being free to move in axial displacement.

A2.5.2 *Axial Load Frame*, a testing machine capable of applying tensile or compressive loads at a constant displacement rate.

A2.5.3 *Test Fixture*, a fixture capable of gripping both ends of the IMFD and ensuring that only torsional moments are applied to the IMFD. If the fixture is used with an axial load frame, the fixture shall be free to slide in the longitudinal direction of the test specimen. The test fixture should be sufficiently rigid so that its rotational deformation under the maximum torque is less than 1 % of the deformation of the test specimen.

A2.5.4 *Torque Transducer*, a calibrated device capable of measuring torsional moments with an accuracy of ± 1 % of its rated full-scale capacity and providing output readable by a suitable recording device.

A2.5.5 *Rotational Transducer*, a calibrated device capable of measuring angular displacement with an accuracy of ± 1 % of its rated full-scale capacity and providing output readable by a suitable recording device.

A2.5.6 *Recording Device*, a recording device capable of plotting the output of the torque transducer and the rotation transducer to provide a torque-rotation curve.

A2.6. Test Specimen

A2.6.1 A straight section of IMFD with an approximate length of 28 cm is recommended. Approximately 2.5 cm at each end shall be gripped by the test fixture. A straight section is required to prevent the simultaneous introduction of bending under the application of the torsional moment.

A2.6.2 The central portion of the test specimen shall have a uniform cross section along the recommended gage length of 23 cm. The ends of the gage length shall be at least one IMFD diameter from any type of stress concentration or change in geometry. The gage length may be changed to accommodate IMFDs that cannot meet the requirement of a 23-cm length of straight and uniform section. In that case, report the gage length used.

A2.6.3 All test components shall be representative of implant quality products with regard to material, cross section, surface finish, and manufacturing processes. IMFDs may differ from actual implant products if the difference is required to obtain a straight nail section. Report any differences.

A2.7. Procedure

A2.7.1 Prepare the ends of the test specimens for gripping. This may include machining three flats along the grip section for securing in Jacob's type chucks. For slotted (open section) IMFDs, the grip section at each end may be potted with a

suitable potting agent such as poly(methyl methacrylate) (PMMA) or potting metal, provided the potting material does not extend into the gage section. Some testers have used a clearance-fit pin inside of the grip ends of the open section IMFD to support the cross section while gripping with a Jacob's type chuck. Report the method used for gripping the specimen.

A2.7.2 Secure the ends of the test specimen into the test fixture to provide the gage length of 23 cm. As indicated in A2.6.2, deviations from the specified gage length are permitted if necessary, provided the gage length is reported. The grips shall directly grip the surface of the nail or the potting material, if applicable.

A2.7.2.1 When a torsional load frame is used, the fixture usually will consist simply of two gripping devices, such as Jacob's chucks, which will prevent rotation of the test specimen inside of the grips. This setup is shown in Fig. A2.1. The axis of the test specimen shall be coincident with the axis of the load frame. Place the axial load controller in load control to apply a small (5 to 10 N) compressive load during the course of the test. If the load frame is not capable of applying axial loads in load control, then one of the fixtures should be free to displace in the longitudinal direction of the test specimen.

A2.7.2.2 When an axial load frame is used, a more sophisticated test fixture is required. An example is shown in Fig. A2.2. It consists of two gripping devices that prevent rotation of the test specimen inside of the grips. The axis of the test specimen shall be coincident with the axes of the two grips. One grip is secured to the torque transducer, which in turn is secured to the test fixture. This grip should be free to displace in the longitudinal direction of the test specimen. The other grip is attached to the test fixture through a bearing that allows the grip to rotate freely. A lever arm is attached to the rotating grip and is used to apply a torsional moment to the test

specimen through its contact with the axial load frame actuator. The load actuator will contact the level arm through a roller some distance from the axis of the test specimen. The roller diameter and lever arm distance may be chosen by the user but shall be reported. The rotation transducer measures the angular displacement of the rotating grip.

A2.7.3 The recording device shall be configured to record a torque-rotation curve. Choose the torque and rotation axes scales to provide sufficient data to determine the slope of the curve.

A2.7.4 The load frame shall be configured to rotate at a constant rate of 5°/min when a torsional load frame is used. When an axial load frame is used, choose a constant displacement rate that will result in a rotation rate that is approximately 5°/min.

A2.7.5 The load frame shall be activated and the torque applied until the test specimen rotates through approximately 5° or until a straight-line portion of the torque-rotation curve is achieved.

A2.8. Calculation or Interpretation of Results

A2.8.1 The initial slope of the straight-line portion of the torque-rotation curve will provide the torsional stiffness of the test specimen.

A2.9. Report

- A2.9.1 Include the following information in the test report:
 - A2.9.1.1 Manufacturer of IMFD specimen;
 - A2.9.1.2 IMFD size and catalog number (if applicable);
 - A2.9.1.3 Material of IMFD specimen;
 - A2.9.1.4 Deviations from normal implant product;
 - A2.9.1.5 Method of gripping, and potting agent and potting diameter used (if applicable);
 - A2.9.1.6 Gage or grip length used, or both, if different from that specified;
 - A2.9.1.7 Average torsional stiffness, standard deviation, and sample size; and
 - A2.9.1.8 Any deviations from the test method.

A2.10. Precision and Bias

A2.10.1 Data establishing the precision and bias to be expected from this test method have not yet been obtained.

A2.11 Rationale (Nonmandatory Information)

A2.11.1 This test method determines the torsional stiffness of an intramedullary fixation device (IMFD). These devices are intended for use as temporary, adjunctive devices for skeletal parts. The torsional stiffness of IMFDs is known to have an effect upon the level of load transfer and level of stress in the surrounding bone and callus and to influence the rate and strength of healing of the bone, as well as long-term remodeling. The specific level of stress and load in the bone related to a specific torsional stiffness is unknown and dependent upon multiple factors such as level and type of activity of the patient, condition of the surrounding bone and soft tissue, stability of the fracture pattern, size of the bone, weight of the patient, and so forth. Measurements of torsional stiffness using this test

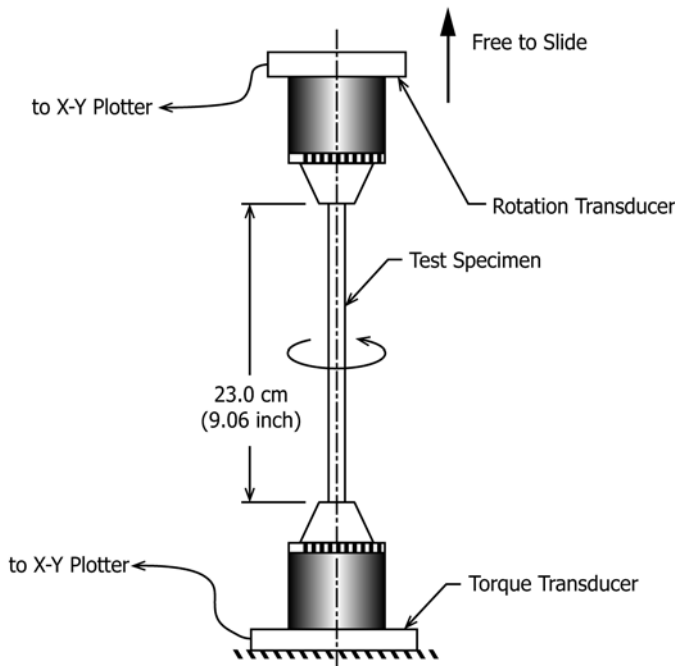

FIG. A2.1 Torsional Load Frame Setup

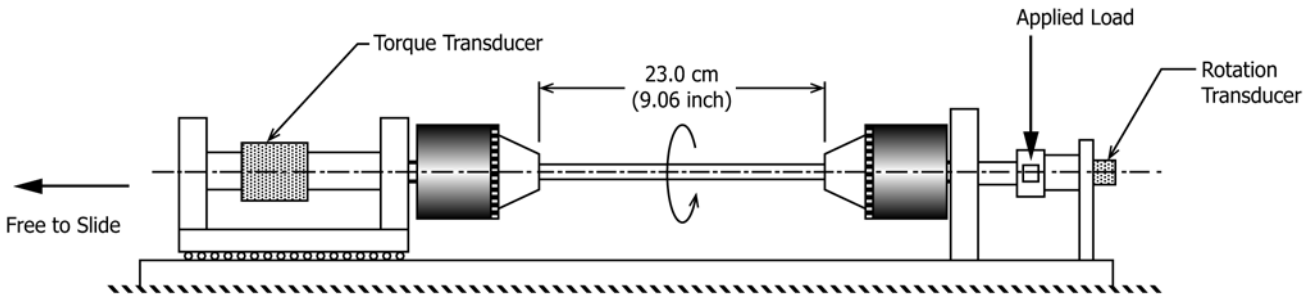

FIG. A2.2 (a) Axial Load Frame Setup Side View

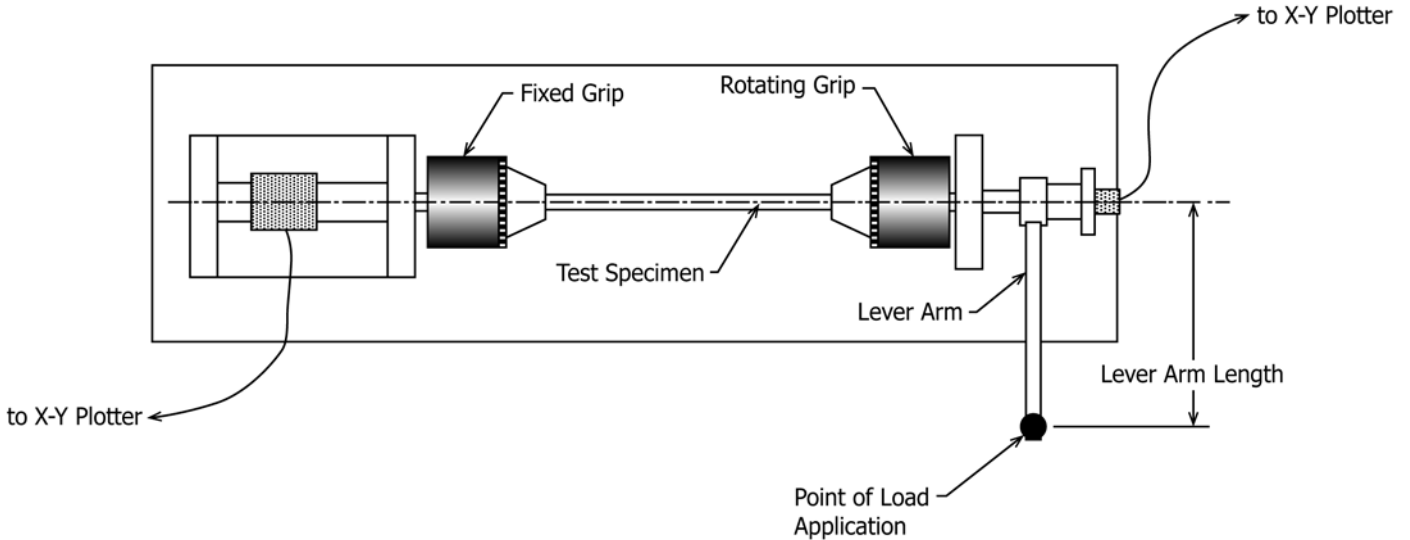

FIG. A2.2 (b) Axial Load Frame Setup Top View (continued)

method, therefore, are only of value for comparative purposes between devices of different sizes, designs, and materials. The

results are not intended to define case-specific clinical performance of the tested devices.

A3. TEST METHOD FOR BENDING FATIGUE TESTING OF INTRAMEDULLARY FIXATION DEVICES

A3.1. Scope

A3.1.1 This test method covers the test procedure for performing cyclic bending fatigue testing of intramedullary fixation devices (IMFDs). The central part of the IMFD, with a straight and uniform cross section and away from screw holes or other interlocking features, is tested in cyclic four-point bending. This method may be used to determine the fatigue life at a specified maximum bending moment or to estimate the fatigue strength for a specified number of cycles.

A3.1.2 This test method is intended to evaluate the cyclic bending fatigue performance of the working length of the IMFD, and may not be appropriate for all situations. When the structurally critical region of the IMFD is shown to be located at the proximal or distal extremity of the device, it may be necessary to evaluate the cyclic bending fatigue performance

of this region of the IMFD using a different test method. This is because it may not be physically possible to fit the proximal or distal extremity between the inner rollers of a four-point bend test. Structurally critical regions may be identified through such methods as hand calculations, finite element analysis, etc. Screw holes or other interlocking features are typically located at the proximal and distal extremities of an IMFD, and may result in structurally critical regions at these locations.

A3.1.3 IMFDs are indicated for surgical fixation of the skeletal system and are typically used in the femur, tibia, humerus, radius, or ulna. Devices that meet the IMFD specifications of Section 4, and other similar devices, are covered by this test method.

A3.1.4 This test method is not intended to test or provide information that will necessarily relate to the properties of fixation which an IMFD may achieve in a bone, or any other connection with other devices.

A3.1.5 This test method is not intended to define case-specific clinical performance of these devices, as insufficient knowledge to predict the consequences of the use of any of these devices in individual patients is available.

A3.1.6 This test method is not intended to serve as a quality assurance document, and thus, statistical sampling techniques for batches from the production of IMFDs are not addressed.

A3.1.7 The values stated in SI units are to be regarded as standard. No other units of measurement are included in this standard.

A3.1.8 *This standard does not purport to address all of the safety concerns, if any, associated with its use. It is the responsibility of the user of this standard to establish appropriate safety and health practices and determine the applicability of regulatory limitations prior to use.*

A3.2. Referenced Documents

A3.2.1 *ASTM Standards*.²

E467 Practice for Verification of Constant Amplitude Dynamic Forces in an Axial Fatigue Testing System

E1823 Terminology Relating to Fatigue and Fracture Testing

A3.3. Terminology

A3.3.1 *Definitions*—Unless otherwise given, the definitions for fatigue terminology given in Terminology **E1823** will be used.

A3.3.1.1 *R ratio, n*—algebraic ratio of the two loading parameters of a fatigue cycle. For the purposes of this test method, the *R* ratio is defined as:

$$R = \text{minimum moment/maximum moment}$$

A3.3.1.2 *nominal stress, n*—stress at a point calculated in the net cross section by simple elastic theory without taking into account the increase in stress that may be caused by a local stress concentrator, such as a hole.

A3.3.1.3 *maximum moment, M, n*—applied bending moment having the highest algebraic value in the loading cycle.

A3.3.1.3.1 *Discussion*—A moment causing tensile stress on the surface of the IMFD specimen which contacts the outer support rollers (as shown in **Fig. A3.1**) is considered positive,

and a moment causing compressive stress is considered negative.

A3.3.1.4 *minimum moment*—applied bending moment having the lowest algebraic value in the loading cycle.

A3.3.1.4.1 *Discussion*—A moment causing tensile stress on the surface of the IMFD specimen which contacts the outer support roller (as shown in **Fig. A3.1**) is considered positive, and a moment causing compressive stress is considered negative.

A3.3.1.5 *median fatigue strength at N cycles, n*—maximum moment at which 50 % of the specimens of a given sample would be expected to survive *N* loading cycles at a specified *R* ratio.

A3.3.1.6 *M-N diagram, n*—plot of maximum moment versus the number of cycles to a specified failure point.

A3.3.1.7 *runout, n*—predetermined number of cycles at which the testing on a particular specimen stopped, and no further testing on that specimen was performed.

A3.3.1.7.1 *Discussion*—When the intent of the fatigue test program is to determine the fatigue strength at *N* cycles, the runout is usually specified as *N* cycles.

A3.3.1.8 *S-N diagram, n*—a plot of stress against the number of cycles to failure. The stress can be maximum stress S_{max} , minimum stress S_{min} , stress range *S* or S_r , or alternating stress S_a . The diagram indicates the *S-N* relationship for a specified value of S_m (*mean stress*) *A*, or *R* (*load or stress ratio*), and a specified probability of survival. For *N*, a log scale is almost always used. For *S*, a linear scale is used most often, but a log scale is sometimes used. **F2809**

A3.4. Summary of Test Method

A3.4.1 An intramedullary fixation device is placed on a four-point bending fixture so that a straight, uniform cross section of specified length is in the gage section. The IMFD is loaded under four-point bending in a sinusoidal cyclic manner at a specified frequency. The fatigue loading is continued until the specimen fails, a limit that terminates the test is reached, or a predetermined number of cycles (runout limit) is reached.

A3.5. Significance and Use

A3.5.1 This test method describes a cyclic bending fatigue test to characterize the fatigue performance of an IMFD. The method may be used to determine the fatigue life at a specified maximum bending moment or to estimate the fatigue strength for a specified number of cycles.

A3.5.2 This test method may not be appropriate for all types of implant applications. The user is cautioned to consider the appropriateness of the method in view of the devices being tested and their potential application.

A3.6. Apparatus

A3.6.1 *Axial Load Frame*—A testing machine capable of applying cyclic sinusoidal tensile or compressive loads.

A3.6.2 *Cycle Counter*—A device capable of counting the number of loading cycles applied to a specimen during the course of a fatigue test.

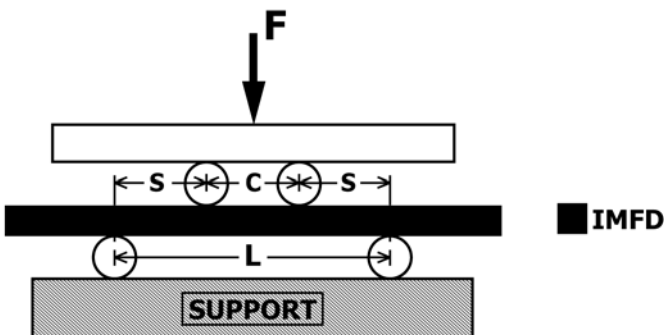

FIG. A3.1 Four-Point Bend Test Setup

A3.6.3 Four-Point Bend Fixture—A two-part fixture (top and bottom) capable of applying a uniform bending moment to the central portion of an IMFD. The IMFD specimen is supported by two outer support rollers, and the moment is applied through two inner loading rollers. This is shown in Fig. A3.1 and is similar to that used for static testing, as described in Annex A1.

A3.6.4 Load Cell—A load cell capable of measuring dynamic tensile or compressive loads or both in accordance with Practice E467.

A3.6.5 Limit—A device capable of detecting when a test parameter (for example, load, actuator displacement, dc error, and so forth) reaches a limiting value, at which time the test is stopped and the current cycle count recorded.

A3.7. Test Specimen

A3.7.1 A straight section of an IMFD or an IMFD with curvature in a single plane is recommended. It is recommended that the central portion of the test specimen have a uniform cross section along the gage length, unless any geometrical features are characteristic of the normal cross section along the IMFD's working length. Deviations from this may be appropriate, as described in A3.7.2.

A3.7.2 The addition of a geometrical feature, such as a hole, may be located in the gage section. For the stated example, this may be useful for evaluating the bending fatigue performance of IMFD screw holes. Any type of feature should be placed in the center of the gage section to maintain a symmetric deflection profile.

A3.7.3 All test components should be representative of implant quality products, with regard to material, cross section, surface finish, and manufacturing processes. Any differences shall be reported.

A3.8. Procedure

A3.8.1 Before testing, the load level for testing shall be determined. To evaluate the fatigue performance of an IMFD, the user has several alternatives or approaches.

A3.8.1.1 *M-N* or *S-N* Diagram—One may test at several load levels to characterize the general fatigue behavior of an IMFD over a range of loads or stresses. The applied moment and the cycles to failure are plotted on a *M-N* diagram. Alternatively, the nominal stress as a result of the applied moment may be determined using analytical, experimental, or computational stress analysis methods, and a *S-N* diagram generated. A curve fit may be applied to the data to develop an *M-N* or *S-N* curve.

A3.8.1.2 *Fatigue Strength Determination*—Another approach is to determine the fatigue strength of a particular IMFD. For the purposes of standardization, the fatigue strength in this standard is determined after one million cycles of loading. A rationale for this criterion is given in Appendix X1. The up-and-down method for determining fatigue strength is a

generally accepted manner for conducting fatigue testing to determine fatigue strength.⁵

For bending fatigue testing described in this test method, the load level is expressed as the maximum moment, *M*, applied to the IMFD specimen.

A3.8.2 The four-point bend fixture should be adjusted so that the span of the outer support rollers, *L*, is between 10 and 50 cm. The inner loading span, *c*, should be no greater than *L*/3. The two span dimensions are shown in Fig. A3.1. The diameter of the load and support rollers should be between 1.0 and 2.6 cm. The spans should be set to within 1 % of their determined values. The choice of load and support spans should be based upon the guidelines given in A1.7.2.

A3.8.3 *Suggested Load Spans*—A recommendation for load and support spans is provided below to minimize interlaboratory variation and provide consistency with the previous ASTM International standard and with the static test method specified in Annex A1. The suggested long or short spans should be used whenever possible, provided the general guidelines of A1.7.2 are achieved.

Short span	$s = c = 38 \text{ mm}$	$L = 114 \text{ mm}$
Long span	$s = c = 76 \text{ mm}$	$L = 228 \text{ mm}$

A3.8.4 The IMFD specimen should be placed on the support rollers so that any CSC or geometrical feature in the gage section is at least three diameters of the IMFD from any load or support roller. If the IMFD is curved, the device should be placed so that the applied bending moment is in the same plane as the IMFD curvature. The orientation of the applied bending relative to the ML and AP anatomic planes should be reported.

A3.8.5 For IMFDs that have rotational instability, the fixtures described in A1.5.1.10 may be used. During fatigue testing, specimens can have the tendency to “walk” during the application of cyclic loading if they are not constrained against such behavior. This can be a problem during four-point bending fatigue tests as the specimens are typically only resting on support rollers. This can be prevented by constructing appropriate guides in combination with the test fixture so as to prevent the specimens from shifting their position during testing. The guides, of course, must not interfere with load application or specimen deformation.

A3.8.6 Apply equal loads at each of the loading points. The maximum applied load, *F*, is determined from:

$$F = 2M/s, \quad (\text{A3.1})$$

where *M* is the maximum moment. The maximum nominal stress applied to the IMFD may be determined using analytical, experimental, or computational methods.

A3.8.7 The loads shall be applied in a sinusoidal cyclic manner at a frequency no greater than 5 Hz. For strain-rate-sensitive materials, an appropriate cyclic rate may be determined using the equation for strain rate given in A1.5.1.4.

A3.8.8 The recommended *R* ratio is 0.1. Any deviations from this should be reported.

⁵ Little, R.E., and Jebe, E.H., *Manual on Statistical Planning and Analysis for Fatigue Experiments, ASTM STP 588*, American Society of Testing and Materials, West Conshohocken, PA, 1975.

A3.8.9 The cycle counter shall record a cumulative number of cycles applied to the test specimen, and the appropriate limits should be set to indicate specimen failure or deviations from the intended load system performance.

A3.8.10 Testing shall continue until the specimen breaks, a limit which terminates the test is reached or the runout criterion is reached.

A3.9. Calculation and Interpretation of Results

A3.9.1 The maximum moment (or stress) and cycles to failure should be recorded and plotted on a $M-N$ (or $S-N$) diagram. Various techniques may be used to estimate mean or median fatigue lives, statistical differences between groups, curve fits to the fatigue data, probability of survival curves, and so on.^{5,6,7}

A3.9.2 When determining fatigue strength at N cycles, it is recommended that the fatigue strength be determined as the median fatigue limit (50 % probability of survival) using a technique or criteria described in the literature.⁵

A3.10. Report

A3.10.1 The test report shall include the following:

A3.10.1.1 Manufacturer of IMFD specimen.

A3.10.1.2 IMFD diameter and catalog number (if applicable).

A3.10.1.3 Material of IMFD specimen, including applicable ASTM or ISO specifications.

A3.10.1.4 Description of deviations from a uniform cross section in the gage length, if any.

A3.10.1.5 Deviations from normal implant product.

A3.10.1.6 Outer support span, L ; inner loading span, c ; span between inner and outer rollers, s ; and roller diameters.

A3.10.1.7 R ratio and the test frequency.

A3.10.1.8 Description of the testing environment.

A3.10.1.9 A summary of the maximum moment (and stress) and the resulting cycles to failure or runout for each specimen tested. The data should be plotted on an $M-N$ or $S-N$ diagram.

⁶ Conway J.B., and Sjodahl, L.H., *Analysis and Representation of Fatigue Data*, ASM International, Materials Park, OH, 1991.

⁷ Collins, J.A., *Failure of Materials in Mechanical Design*, John Wiley and Sons, New York, 1981.

A description of the analytical or statistical techniques used for interpretation of the fatigue data should be included.

A3.10.1.10 A description of the failure mode and failure location for each specimen which failed.

A3.10.1.11 If appropriate, an estimate of the fatigue strength should be reported. A description of the analytical or statistical techniques used for determining the fatigue strength should be included.

A3.11. Precision and Bias

A3.11.1 Data establishing the precision and accuracy to be expected from this test method have not yet been obtained.

A3.12 Rationale

A3.12.1 The low-cycle bending fatigue strength of IMFDs is known to be an important factor in cases in which bone support is minimal and when healing is delayed. In such cases, major stresses may occur in the unsupported region of the working length of the IMFD over several weeks before development of adequate mechanical support from the healing bone to reduce the level of stresses in the IMFD. Since the levels or load which the IMFD must bear in any given case are uncontrollable and unpredictable, there is no “acceptable” limit for the bending moment or number of cycles of load which the IMFD should withstand in any plane that can be set.

A3.12.2 One of the objectives of this test is to estimate the fatigue strength at 10^6 cycles for comparison of different devices. Since these are trauma fixation devices whose service life is limited and mechanical demands are finite in time, no definition of endurance limit is necessary. One million cycles was arbitrarily chosen as the number of cycles for testing, recognizing that no IMFD in clinical service is expected to withstand 10^6 loading cycles of *high stresses* in clinical use. Fractures and skeletal reconstructions generally heal in two to three months (about 150 000 to 250 000 cycles) normally. Therefore, the fatigue resistance at 10^6 cycles is beyond the expected clinical need for these devices.

A3.12.3 Finally, measurements of cyclic bending fatigue strength or fatigue life using this standard testing technique are only of value for comparative purposes between devices of different sizes, designs, materials, and materials.

A4. TEST METHOD FOR BENDING FATIGUE TESTING OF IMFD LOCKING SCREWS

A4.1. Scope

A4.1.1 This test method covers the test procedure for performing cyclic bending fatigue testing of locking screws used for the fixation of intramedullary fixation devices (IMFDs). The central part of the screw is tested in cyclic three-point or four-point bending. This method may be used to

determine the fatigue life at a specified maximum bending moment or to estimate the fatigue strength for a specified number of cycles.

A4.1.2 This test method is specifically applicable to screws described by Specification **F543**, which are used to provide fixation of IMFDs in bone by transversely crossing through the

IMFD from one cortex to the other. This test method may or may not be applicable to other types of orthopaedic bone screws.

A4.1.3 This test method does not address the connection between the IMFD and the screw.

A4.1.4 This test method is not intended to define case-specific clinical performance of these devices, as insufficient knowledge to predict the consequences of the use of any of these devices in individual patients is available.

A4.1.5 This test method is not intended to serve as a quality assurance document, and thus, statistical sampling techniques for batches from the production of screws are not addressed.

A4.1.6 The values stated in SI units are to be regarded as standard. No other units of measurement are included in this standard.

A4.1.7 *This standard does not purport to address all of the safety concerns, if any, associated with its use. It is the responsibility of the user of this standard to establish appropriate safety and health practices and determine the applicability of regulatory limitations prior to use.*

A4.2. Referenced Documents

A4.2.1 *ASTM Standards:*²

E467 Practice for Verification of Constant Amplitude Dynamic Forces in an Axial Fatigue Testing System

E1823 Terminology Relating to Fatigue and Fracture Testing

F543 Specification and Test Methods for Metallic Medical Bone Screws

A4.3. Terminology

A4.3.1 *Definitions*—Unless otherwise given, the definitions for fatigue terminology given in Terminology **E1823** will be used.

A4.3.2 *Definitions of Terms Specific to This Standard:*

A4.3.2.1 *maximum moment, n*—applied bending moment having the highest algebraic value in the loading cycle.

A4.3.2.1.1 *Discussion*—A moment causing tensile stress on the surface of the screw specimen which contacts the outer support rollers (see **Fig. A4.1**) is considered positive and a moment causing compressive stress is considered negative.

A4.3.2.2 *median fatigue strength at N cycles, n*—maximum moment at which 50 % of the specimens of a given sample would be expected to survive *N* loading cycles at a specified *R* ratio.

A4.3.2.3 *minimum moment, n*—applied bending moment having the lowest algebraic value in the loading cycle.

A4.3.2.3.1 *Discussion*—A moment causing tensile stress on the surface of the screw specimen which contacts the outer support rollers (see **Fig. A4.1**) is considered positive and a moment causing compressive stress is considered negative.

A4.3.2.4 *M-N diagram, n*—plot of maximum moment versus the number of cycles to a specified failure point.

A4.3.2.5 *R ratio, R, n*—algebraic ratio of the two loading parameters of a fatigue cycle. For the purposes of this test method the *R* ratio is defined as follows:

$$R = \text{minimum moment/maximum moment}$$

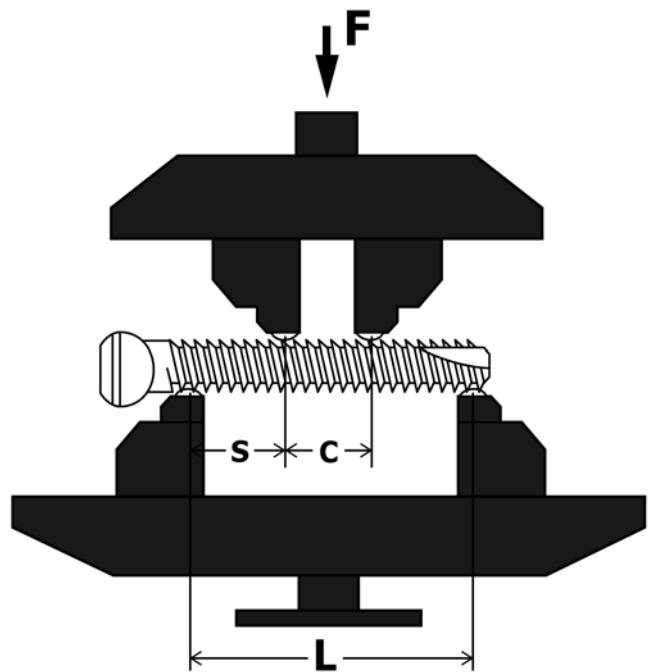

FIG. A4.1 Four-Point Bending Test Setup

A4.3.2.6 *runout, n*—a predetermined number of cycles at which the testing on a particular specimen will be stopped and no further testing on that specimen will be performed.

A4.3.2.6.1 *Discussion*—When the intent of the fatigue test program is to determine the fatigue strength at *N* cycles, the runout usually is specified as *N* cycles.

A4.3.2.7 *S-N diagram*—a plot of stress against the number of cycles to failure. The stress can be maximum stress S_{max} , minimum stress S_{min} , stress range *S* or S_r , or alternating stress S_a . The diagram indicates the *S-N* relationship for a specified value of S_m (*mean stress*) *A*, or *R* (*load or stress ratio*), and a specified probability of survival. For *N*, a log scale is almost always used. For *S*, a linear scale is used most often, but a log scale is sometimes used. **F2809**

A4.4. Summary of Test Method

A4.4.1 A screw is placed on a three-point or four-point bending fixture so that a straight and regular section of specified length is in the gage section. The screw is loaded under three-point or four-point bending in a sinusoidal cyclic manner at a specified frequency. The fatigue loading is continued until the specimen fails, a limit which terminates the test is reached, or a predetermined number of cycles (runout limit) is reached.

A4.5. Significance and Use

A4.5.1 This test method describes a cyclic bending fatigue test to characterize the fatigue performance of an IMFD locking screw. The method may be used to determine the fatigue life at a specified maximum bending moment or to estimate the fatigue strength for a specified number of cycles.

A4.5.2 This test method may not be appropriate for all types of implant applications. The user is cautioned to consider the

appropriateness of the method in view of the devices being tested and their potential application.

A4.6. Apparatus

A4.6.1 *Axial Load Frame*—A testing machine capable of applying cyclic sinusoidal tensile or compressive loads.

A4.6.2 *Cycle Counter*—A device capable of counting the number of loading cycles applied to a specimen during the course of a fatigue test.

A4.6.3 *Four-Point Bending Fixture*—A two-part fixture (top and bottom) capable of applying a uniform bending moment to the central portion of a screw. The screw specimen is supported by two outer support rollers, and the moment is applied through two inner loading rollers (see Fig. A4.1).

A4.6.4 *Three-Point Bending Fixture*—A two-part fixture (top and bottom) capable of applying a three-point bending moment to the central portion of a screw. The screw specimen is supported by two outer support rollers, and the moment is applied through a single roller which is centered between the two outer support rollers (see Fig. A4.2).

A4.6.5 *Load Cell*—A load cell capable of measuring dynamic tensile, or compressive loads or both in accordance with Practice E467.

A4.6.6 *Limit*—A device capable of detecting when a test parameter, for example, load, actuator displacement, DC error, and so forth, reaches a limiting value, at which time the test is stopped and the current cycle count recorded.

A4.7. Test Specimen

A4.7.1 A straight and regular section of a screw thread, or the central portion of screw, shall be used for testing. The thread diameter and core diameter shall be consistent through-

out the intended gage section with no steps or other geometric discontinuities, other than from the threads themselves.

A4.7.2 All test components should be representative of implant quality products, with regard to material, cross section, surface finish, and manufacturing processes. Any differences shall be reported.

A4.8. Procedure

A4.8.1 Before testing, the load level for testing shall be determined. To evaluate the fatigue performance of a screw, the user has several alternatives or approaches.

A4.8.1.1 *M-N or S-N Diagram*—One may test at several load levels to characterize the general fatigue behavior of a screw over a range of loads or stresses. The applied moment and the cycles to failure are plotted on a *M-N* diagram. Alternatively, the stress caused by the applied moment may be determined using analytical, experimental, or computational stress analysis methods and a *S-N* diagram generated. A curve fit may be applied to the data to develop a *M-N* or *S-N* curve.

A4.8.1.2 *Fatigue Strength Determination*—Another approach is to determine the fatigue strength of a particular screw. For the purposes of standardization, the fatigue strength in this test method is determined at one million cycles of loading. A rationale for this criterion is given in Appendix X1. The up-and-down method is a generally accepted method for conducting fatigue testing to determine fatigue strength.⁵

For bending fatigue testing described in this test method, the load level is expressed as the maximum moment, *M*, applied to the screw.

A4.8.2 Depending on the length of the screw, either a three-point or four-point bending fixture shall be used. Generally, it is favorable to use four-point bending because the central portion of the specimen is subjected to a uniform bending moment; however, for short screws, it may not be practical to fit all four loading points along the screw length. The choice of three-point or four-point bending, and the span lengths to use in either case, is left to the discretion of the user. The choice of support spans should be based upon the guidelines given in A1.9.1.

A4.8.2.1 *Four-Point Bending*—The four-point bending fixture should be adjusted to the chosen span of the outer loading rollers, *L*. The inner loading span, *c*, should be no greater than *L*/3. The test setup is shown in Fig. A4.1.

A4.8.2.2 *Three-Point Bending*—The three-point bending fixture should be adjusted to the chosen span of the outer support rollers, *L*. The upper loading roller shall be centered between the outer support rollers. The test setup is shown in Fig. A4.2.

A4.8.3 The load and support rollers shall be made of hardened steel and have a diameter which is two to four times greater than the thread pitch of the screw being tested. The screw shall be placed on the loading fixture so that the support rollers sit between the crests of two adjacent threads. This may require some adjustment of the fixture spans to accommodate the particular screw being tested.

A4.8.4 Apply equal loads at each of the loading points. The maximum applied load, *F*, is determined from the following:

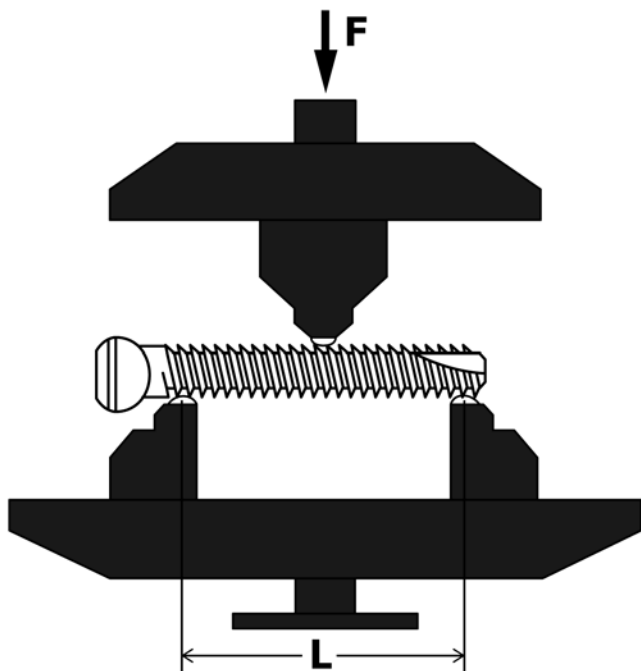

FIG. A4.2 Three-Point Bending Test Setup

$$F = 2M/s \quad (\text{A4.1})$$

where:

M = the maximum moment. The maximum stress applied to the IMFD may be determined using analytical, experimental, or computational methods.

A4.8.5 The loads shall be applied in a sinusoidal cyclic manner at a frequency no greater than 5 Hz.

A4.8.6 The recommended R ratio is 0.1. Any deviations from this should be reported.

A4.8.7 The cycle counter shall record a cumulative number of cycles applied to the test specimen, and the appropriate limits should be set to indicate specimen failure or deviations from the intended load system performance.

A4.8.8 Testing shall continue until the specimen breaks, a limit which terminates the test is reached, or a predetermined runout criterion is reached.

A4.9. Calculation and Interpretation of Results

A4.9.1 The maximum moment (or stress) and cycles to failure should be recorded and plotted on an $M-N$ (or $S-N$) diagram. Various techniques may be used to estimate mean or median fatigue lives, statistical differences between groups, curve fits to the fatigue data, probability of survival curves, and so forth.^{5,6,7}

A4.9.2 When determining fatigue strength at N cycles, it is recommended that the fatigue strength be determined as the median fatigue limit (50 % probability of survival), using a technique or criteria described in the literature.⁵

A4.10. Report

A4.10.1 The test report shall include the following:

A4.10.1.1 Manufacturer of screw.

A4.10.1.2 Screw type, size (diameter and length), and catalog number, if applicable.

A4.10.1.3 Material of screw specimen, including applicable ASTM International or ISO specifications.

A4.10.1.4 Description of deviations from a regular cross section in the gage length, if any.

A4.10.1.5 Deviations from normal implant product.

A4.10.1.6 Type of bending applied; outer support span, L ; Inner loading span, c , if applicable; span between inner and outer rollers, s , if applicable; and roller diameters.

A4.10.1.7 R ratio and the test frequency.

A4.10.1.8 Description of the testing environment.

A4.10.1.9 A summary of the maximum moment, or stress, and the resulting cycles to failure or runout for each specimen tested. The data should be plotted on a $M-N$ or $S-N$ diagram. A description of the analytical or statistical techniques used for interpretation of the fatigue data should be included.

A4.10.1.10 A description of the failure mode and failure location for each specimen that failed.

A4.10.1.11 If appropriate, an estimate of the fatigue strength should be reported. A description of the analytical or statistical techniques used for determining the fatigue strength should be included.

A4.11. Precision and Bias

A4.11.1 Data establishing the precision and bias to be expected from this test method have not yet been obtained.

APPENDIX

(Nonmandatory Information)

X1. RATIONALE

X1.1 This specification is intended to provide useful and consistent information related to the terminology, performance, test methods, and application of intramedullary fixation devices. IMFD geometrical definitions, dimensions, classification, and terminology; material specifications; and performance definitions are provided in Sections 1 – 5. A rationale for the importance of particular performance characteristics and a reference to applicable test methods are given in Section 6. Some of the applicable test methods are given in the Annexes. Currently, standard test methods for static four-point bending, static torsion, and cyclic bending fatigue are provided in Annex A1, Annex A2, Annex A3, respectively.

X1.2 The orthopaedic surgeon should be able to choose the size, design, and orientation of an implant and the manner of preparation of the bone for the appropriate fit of the IMFD to each individual patient. To do this, the surgeon must have confidence that the designation of size of the implant and its instrumentation has a specific, known meaning which is quantifiable and reliable, regardless of the manufacturer or

design. The mechanical behavior and material properties must also be described in a reliable, known manner which is irrespective of the manufacturer or design. To accomplish this uniformity of designations, the terminology, dimensions, tolerances, mechanical properties, material properties, and test methods for obtaining and reporting these parameters must be standardized.

X1.3 The original specification (F1264 – 89) defined the performance characteristics important to the *in vivo* performance of the device. Previous revisions modified the standard to incorporate three test methods (static four-point bending static torsion and cyclic fatigue bending) that define the criteria and methods to be used in determining some of the performance characteristics. The task group is currently working on additional test methods which can be used to determine the remaining performance characteristics defined in Section 6. Those test methods will be added to this specification as annexes when they become available. It is the intent of the task group to provide specifications and test methods for all

performance characteristics of Section 6 in one document for easy reference and eventually to replace Specification F339 and all design-specific standards for IMFDS with this specification. The latest revision of this specification adds the dimension for the extractor hooks and accompanying slots used

to extract some intramedullary pin designs (that was specified in Specification F339) and includes repeatability and reproducibility information for the test method described in Annex A1 as determined in an interlaboratory round-robin test program.

ASTM International takes no position respecting the validity of any patent rights asserted in connection with any item mentioned in this standard. Users of this standard are expressly advised that determination of the validity of any such patent rights, and the risk of infringement of such rights, are entirely their own responsibility.

This standard is subject to revision at any time by the responsible technical committee and must be reviewed every five years and if not revised, either reapproved or withdrawn. Your comments are invited either for revision of this standard or for additional standards and should be addressed to ASTM International Headquarters. Your comments will receive careful consideration at a meeting of the responsible technical committee, which you may attend. If you feel that your comments have not received a fair hearing you should make your views known to the ASTM Committee on Standards, at the address shown below.

This standard is copyrighted by ASTM International, 100 Barr Harbor Drive, PO Box C700, West Conshohocken, PA 19428-2959, United States. Individual reprints (single or multiple copies) of this standard may be obtained by contacting ASTM at the above address or at 610-832-9585 (phone), 610-832-9555 (fax), or service@astm.org (e-mail); or through the ASTM website (www.astm.org). Permission rights to photocopy the standard may also be secured from the Copyright Clearance Center, 222 Rosewood Drive, Danvers, MA 01923, Tel: (978) 646-2600; <http://www.copyright.com/>