



# Standard Specification for Berths, Marine<sup>1</sup>

This standard is issued under the fixed designation F1244; the number immediately following the designation indicates the year of original adoption or, in the case of revision, the year of last revision. A number in parentheses indicates the year of last reapproval. A superscript epsilon ( $\epsilon$ ) indicates an editorial change since the last revision or reapproval.

## 1. Scope

1.1 This specification covers the construction of marine berths for officers, crew, and passengers.

1.2 The values stated in inch-pound units are to be regarded as the standard. The values given in parentheses are for information only.

## 2. Referenced Documents

2.1 *ASTM Standards*:<sup>2</sup>

[A512 Specification for Cold-Drawn Buttweld Carbon Steel Mechanical Tubing](#)

[A1008/A1008M Specification for Steel, Sheet, Cold-Rolled, Carbon, Structural, High-Strength Low-Alloy, High-Strength Low-Alloy with Improved Formability, Solution Hardened, and Bake Hardenable](#)

[F825 Specification for Drawers, Furniture, Marine, Steel](#)

[F1085 Specification for Mattress and Box Springs for Use in Berths in Marine Vessels](#)

2.2 *American Institute of Steel Construction Manual*:<sup>3</sup>

[AISC Wire and Sheet Metal Gages-Equivalent Thicknesses in Decimals of an Inch, U.S. Standard Gage for Uncoated, Hot and Cold Rolled Sheets](#)

## 3. Terminology

3.1 *Definitions of Terms Specific to This Standard*:

3.1.1 *base*—the structure on which the drawer and pan sections are supported and which serves to tie the berth to the deck.

3.1.2 *berth*—an item of fixed or built-in furniture for sleeping, with a base and drawer section below the mattress and box spring pan.

<sup>1</sup> This specification is under the jurisdiction of ASTM Committee F25 on Ships and Marine Technology and is the direct responsibility of Subcommittee F25.03 on Outfitting and Deck Machinery.

Current edition approved May 1, 2013. Published May 2013. Originally approved 1989. Last previous edition approved in 2008 as F1244 – 08. DOI: 10.1520/F1244-08R13.

<sup>2</sup> For referenced ASTM standards, visit the ASTM website, [www.astm.org](http://www.astm.org), or contact ASTM Customer Service at [service@astm.org](mailto:service@astm.org). For *Annual Book of ASTM Standards* volume information, refer to the standard's Document Summary page on the ASTM website.

<sup>3</sup> Available from American Institute of Steel Construction (AISC), One E. Wacker Dr., Suite 700, Chicago, IL 60601-2001, <http://www.aisc.org>.

3.1.3 *berth side rail*—the berth side that runs from head to foot of berth.

3.1.4 *box spring*— the resilient box-type support for the mattress covered by fabric.

3.1.5 *drawer section*—the section of the berth below the pan section normally designed to contain drawers for stowage of life preservers and other items.

3.1.6 *hand*—the berth may be right hand, left hand, or finished both sides for use in the middle of the room. Right hand is defined as follows: the berth is right hand if the head of the berth is on the right hand end when the berth is viewed from the front. Left hand is opposite. See [Fig. 1](#) and [Fig. 2](#) and [Table 1](#) and [Table 2](#) for elevations of left-handed berths. A berth finished on both sides is not shown, but it is one that is accessible from either side, has the head of the berth against a bulkhead, and is not handed.

3.1.7 *lee rail*—a guard to inhibit a person from rolling out of bed because of ship motion. In this specification, the lee rail is a raised pine railing.

3.1.8 *mattress*—a fabric-covered, box-type unit containing springs and cushioning material that supports the sleeping surface.

3.1.9 *pan section*—the section of the berth designed to support the mattress and box spring.

## 4. Classification

4.1 *Type I*—A single berth with pipe, side lee rail with a box spring and mattress pan having inside measurements of 54 in. (1372 mm) wide by 80½ in. (2045 mm) long. (See [Fig. 1](#), [Table 1](#), and [Note 8](#) and [Note 11](#) of [Fig. 1](#).)

4.1.1 *Type IA*—Berths conforming generally to the Type I specifications but having special requirements as indicated in the ordering information.

4.2 *Type II*—A single berth with pipe, side lee rail with a box spring and mattress pan having inside measurements of 39 in. (991 mm) wide by 80½ in. (2045 mm) long. (See [Fig. 1](#), [Table 1](#), and [Note 8](#) and [Note 11](#) of [Fig. 1](#).)

4.2.1 *Type IIA*—Berths conforming generally to the Type II specifications but having special requirements as indicated in the ordering information.

4.3 *Type III*—A two-high berth with pipe, side lee rail, the same as Type II, but fitted with an additional pan and uprights

to form an upper berth. (See Fig. 2, Table 2, and Note 8, Note 10, and Note 11 of Fig. 1.)

4.3.1 *Type IIIA*—Berths conforming generally to the Type III specifications but having special requirements as indicated in the ordering information.

**5. Ordering Information**

5.1 Orders for items purchased under this specification shall include the following:

5.1.1 Type of berth.

5.1.1.1 Type I, IA; II, IIA; or III, IIIA.

5.1.1.2 *Hand*—Right, left, or finished both sides.

5.1.2 *Quantity*—The quantity of right hand, left hand, or finished both sides for each type.

5.1.4.2 The manufacturer’s standard baked enamel will be furnished unless otherwise required and specified by the purchaser.

5.1.5 *Weights*—If the total weight of the berth assembly is required, it shall be requested by the purchaser.

5.1.6 *Options:*

5.1.6.1 If a special architectural appearance or finish is required for these berths to match other furniture in the same space, it shall be defined in the ordering documents.

5.1.6.2 The pipe lee rail at the foot of all berths shall be furnished extending above the mattress, to restrain occupants in heavy sea.

5.1.6.3 Normally, on berths installed in a corner, the head of the berth is installed against one of the bulkheads. On some

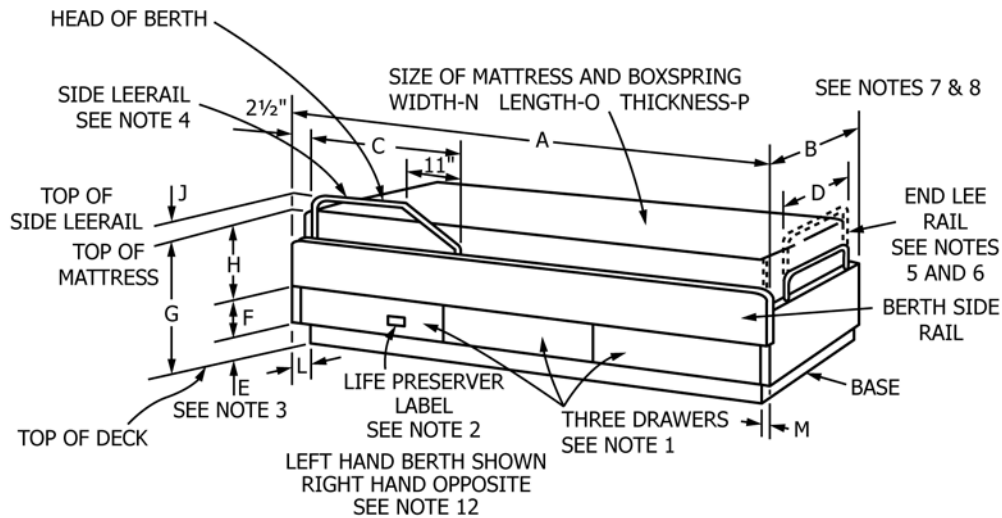

NOTE 1—For a description of the drawers, see Specification F825. The minimum stowage capacity of each drawer shall be 1.35 ft<sup>3</sup> (0.038 m<sup>3</sup>) (drawer pulls not shown).

NOTE 2—The location of life preserver stowage shall be indicated on the front face of one drawer. See 6.10 for description.

NOTE 3—The minimum value for Dimension “E” (toe space height) shall be 3/4 in. (83 mm).

NOTE 4—Berth Types I, II, or III, with pipe rail detail, will be supplied as shown on Fig. 1. For description of pipe rail, see 6.12.

NOTE 5—End lee rail for bottom berths that are to be installed athwartship shall be furnished extending above the mattress, to restrain occupant in heavy seas. (See 5.1.6.2.)

NOTE 6—See 6.12 for a description of the pipe lee rail.

NOTE 7—For a description of the mattress and box springs, see Specification F1085.

NOTE 8—The mattress and box spring are ordered 1 in. (25.4 mm) smaller in width and length than the inside dimensions of the berth pan.

NOTE 9—Dimensions G, H, I, and J are shown as nominal dimensions, without tolerances. Their real value depends upon the tolerance of the thickness of the mattress and the box spring. The commercial tolerance on these thicknesses is ± 1/2 in. (12 mm).

NOTE 10—Where ceiling heights are low, overhead clearance, Dimension I, should be equalized between upper and lower berths. Minimum clearance is 20 in. (508 mm).

NOTE 11—Fig. 1 and Fig. 2 depict the basic berth Types I, II, and III covered by these specifications. If special architectural requirements are needed to match other furniture in the same area, they shall be defined in the ordering specifications and berths will be identified as Types IA, IIA, and IIIA.

NOTE 12—For hand of berths see 3.1.6.

**FIG. 1 Type I (53-in. (1345-mm) wide mattress) and Type II (38-in. (965-mm) wide mattress) Berths With Pipe, Side Lee Rail**

5.1.3 *Mattress and Box Spring*—Shall be furnished in accordance with Specification F1085.

5.1.4 *Paint:*

5.1.4.1 *Color*—The purchaser shall pick from manufacturer’s samples or submit a sample chip of the color desired.

smaller ships, the trim of the vessel is such that this configuration would place the foot of the berth higher than the head. In such cases, the head and foot shall be reversed, and this requirement shall be so noted in the ordering document.

**TABLE 1 Dimensions of Type I and Type II Berths**

Designation	in.		mm		Note (See Fig. 1)	
	Dimension	Tolerance to + or -	Dimension	Tolerance to + or -		
Length	A	85	max	2159	max	
Type I width	B	59	max	1499	max	
Type II width	B	44	max	1118	max	
Lee rail length	C	30	min	762	min	
Lee rail length	D	24	min	610	min	
Toe space height	E	4¾	...	121	...	See Note 3.
Drawer section height	F	6½	⅓	165	3	
Deck to mattress	G	24¾	...	629	...	See Note 9.
Box spring plus mattress height	H	13½	...	343	...	See Note 9.
Lee rail height	J	6½	...	165	...	See Note 9.
Toe space, front	L	1½	min	38	min	
Toe space, end	M	¼	min	6	min	
Type I mattress or box spring width	N	53	...	1346	...	See Notes 7-9.
Type II mattress or box spring width	N	38	...	965	...	See Notes 7-9.
Mattress or box spring length	O	79½	...	2019	...	See Notes 7-9.
Mattress or box spring thickness	P	7	...	178	...	

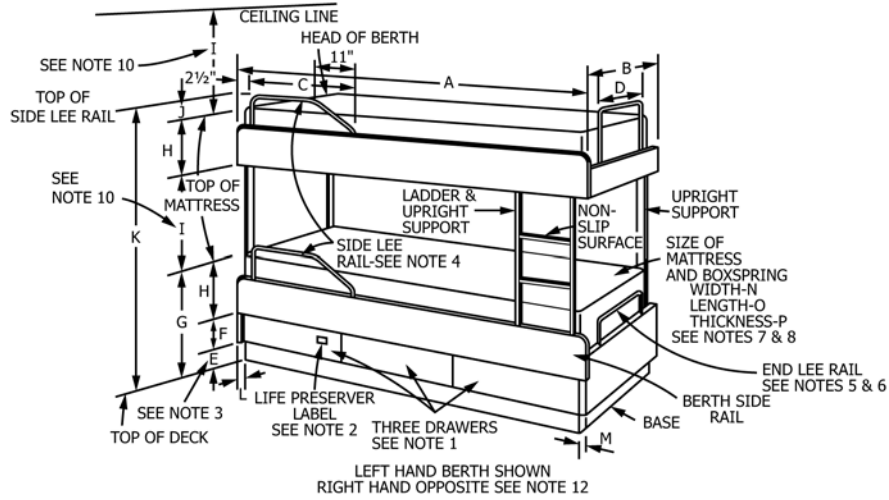

NOTE 1—See Notes 1-12 under Fig. 1.

**FIG. 2 Type III (38-in. (965-mm) Wide Mattress) Berths With Side Lee Rail**

**TABLE 2 Dimensions of Type III Berths**

Designation	in.		mm		Note (See Fig. 1)	
	Dimension	Tolerance to + or -	Dimension	Tolerance to + or -		
Length	A	85	max	2159	max	
Width	B	44	max	1118	max	
Lee rail length	C	30	min	762	min	
Lee rail length	D	24	min	610	min	
Toe space height	E	4¾	...	121	...	See Note 3.
Drawer section height	F	6½	⅓	165	3	
Deck to mattress	G	24¾	...	629	...	See Note 9.
Box spring plus mattress height	H	13½	...	343	...	See Note 9.
Overhead clearance	I	23¾	...	619	...	See Note 9 and Note 10.
Lee rail height	J	6½	...	165	...	See Note 9.
Overall height	K	68½	max	1730	max	
Toe space, front	L	1½	min	38	min	
Toe space, end	M	¼	min	6	min	
Type II mattress or box spring width	N	38	...	965	...	See Notes 7-9.
Mattress or box spring length	O	79½	...	2019	...	See Notes 7-9.
Mattress or box spring thickness	P	7	...	178	...	See Notes 7-9.

## 6. Materials and Manufacture

6.1 For berth details, see [Fig. 1](#) and [Fig. 2](#) and [Table 1](#) and [Table 2](#).

### 6.2 Sheet Metal:

6.2.1 Sheet metal shall be cold rolled carbon commercial sheet (CS) steel (0.15 maximum percent carbon), in accordance with Specification [A1008/A1008M](#).

6.2.2 Minimum steel sheet metal thicknesses shall be as follows:

6.2.2.1 Drawer section 18 USSG (0.0478 in. or 1.21 mm).

6.2.2.2 Pan section 18 USSG (0.0478 in. or 1.21 mm).

6.2.2.3 Base frame 16 USSG (0.0598 in. or 1.52 mm).

### 6.3 Welding:

6.3.1 Metal components shall be joined by welding.

6.3.2 Welding shall be adequate to prevent racking of berth components during handling.

6.3.3 Spotwelds shall be spaced approximately 3 to 5 in. (76 to 127 mm) on centers.

6.3.4 Spotwelds, on exposed surfaces, higher than the general surface of the adjacent metal, shall be ground flush.

6.3.5 Spotweld depressions, on exposed surfaces, shall be spot filled and sanded.

6.4 Side and end panels shall be suitably stiffened to prevent buckling or oil-canning.

6.5 Sound deadening shall be vermin proof and applied to unstiffened areas where needed, and in thickness required, to sound deaden berth.

6.6 Drawers shall be manufactured in accordance with Specification [F825](#). Minimum stowage capacity for each drawer shall be 1.35 ft<sup>3</sup> (0.038 m<sup>3</sup>).

6.7 A furniture base shall be provided suitable for securing berth to deck. Base shall be equipped with means for leveling when installed aboard ship.

6.8 The mattress and box spring shall be manufactured in accordance with Specification [F1085](#). Mattress and box spring sizes shall be as specified in [Table 3](#).

6.9 It is acceptable to make berths in sections: base, drawer section, and berth pan. At the option of the furniture manufacturer, it is acceptable to furnish the berth pan section either as an integral part of the drawer section or as a separate unit. The base shall be suitable for securing to the deck. The other sections shall be attached to the base and to each other so as to form a unit that is adequately secured and capable of resisting motions of the vessel. Berths shall have backs suitable for securing to bulkheads.

6.10 The drawer for stowing life preservers shall be identified by the words “life preserver” in letters  $\frac{1}{4} \pm \frac{1}{32}$  in. ( $6.4 \pm 0.8$  mm) high on the face of the drawer.

6.11 Berths supplied in accordance with this specification will use pipe, side lee rails.

6.12 Pipe lee rail shall be 1-in. (25.4-mm) outside diameter by 0.065-in. (1.65-mm) cold-drawn buttweld carbon steel tubing per Specification [A512](#). Equal strength pipe rail of aluminum or other metals in appropriate finishes can be supplied, if so specified in the ordering documents.

## 7. Performance Requirements

7.1 The completed berth assembly with drawers installed, but without a mattress or box spring, shall satisfy the corresponding performance requirements of the following:

7.1.1 Specification [F825](#).

7.1.2 The berths, without mattress or box springs, shall be capable of supporting a minimum vertical load of 500 lb (4.90 kN) applied uniformly over the entire sleeping surface or a single 250-lb (2.45-kN) vertical load applied over a 1-ft<sup>2</sup> (0.093-m<sup>2</sup>) area anywhere on the berth, without causing permanent deformations.

## 8. Dimensions

8.1 For dimensions, see [Table 1](#) and [Table 2](#).

## 9. Workmanship, Finish, and Quality Assurance

9.1 All workmanship and material shall be of specified quality in keeping with the best commercial marine practice so as to produce each item suitable for its intended use.

9.2 All exposed burrs and raw or sharp edges that might be injurious to personnel or damage linens shall be removed.

9.3 Depressions considered unacceptable for the product’s end use shall be spot filled and sanded smooth.

9.4 All steel surfaces, unless corrosion resistant or with a corrosion resistant plating, shall be painted so as to prevent corrosion.

## 10. Inspection and Certification

10.1 The manufacturer shall inspect and certify that the item of furniture complies with this furniture specification and the loading requirements as defined in [Section 7](#).

## 11. Packaging and Package Marking

11.1 Each item shall be marked in accordance with the purchase order.

11.2 Packaging shall be provided and shall be acceptable to a common carrier.

## 12. Keywords

12.1 berth; box spring; lee rail; marine; marine berth; mattress; ship

**TABLE 3 Size of Mattress and Box Spring<sup>A</sup>**

Berth Type	Mattress or Box Spring			
	Type	Width	Length	Thickness
I	I	53 in. (1345 mm)	79½ in. (2020 mm)	7 in. (180 mm)
II and III	II	38 in. (965 mm)	79½ in. (2020 mm)	7 in. (180 mm)

<sup>A</sup>Tolerances: Width and length =  $\pm \frac{1}{2}$  in. ( $\pm 12$  mm); thickness =  $\pm \frac{1}{2}$  in. ( $\pm 12$  mm).

 **F1244 – 08 (2013)**

*ASTM International takes no position respecting the validity of any patent rights asserted in connection with any item mentioned in this standard. Users of this standard are expressly advised that determination of the validity of any such patent rights, and the risk of infringement of such rights, are entirely their own responsibility.*

*This standard is subject to revision at any time by the responsible technical committee and must be reviewed every five years and if not revised, either reapproved or withdrawn. Your comments are invited either for revision of this standard or for additional standards and should be addressed to ASTM International Headquarters. Your comments will receive careful consideration at a meeting of the responsible technical committee, which you may attend. If you feel that your comments have not received a fair hearing you should make your views known to the ASTM Committee on Standards, at the address shown below.*

*This standard is copyrighted by ASTM International, 100 Barr Harbor Drive, PO Box C700, West Conshohocken, PA 19428-2959, United States. Individual reprints (single or multiple copies) of this standard may be obtained by contacting ASTM at the above address or at 610-832-9585 (phone), 610-832-9555 (fax), or [service@astm.org](mailto:service@astm.org) (e-mail); or through the ASTM website ([www.astm.org](http://www.astm.org)). Permission rights to photocopy the standard may also be secured from the Copyright Clearance Center, 222 Rosewood Drive, Danvers, MA 01923, Tel: (978) 646-2600; <http://www.copyright.com/>*