



Standard Specification for Turnbuckles, Swaged, Welded, Forged¹

This standard is issued under the fixed designation F1145; the number immediately following the designation indicates the year of original adoption or, in the case of revision, the year of last revision. A number in parentheses indicates the year of last reapproval. A superscript epsilon (ϵ) indicates an editorial change since the last revision or reapproval.

This standard has been approved for use by agencies of the U.S. Department of Defense.

1. Scope

1.1 This specification covers swaged welded, cast, or forged turnbuckles with and without jam nuts.

1.2 A turnbuckle is an internally threaded loop or sleeve intended for assembly with a threaded stud, eye, hook, or jaw at each end, used for applying tension to rods, wire rope, and so forth.

1.3 The values stated in inch-pound units are to be regarded as standard. The values given in parentheses are mathematical conversions to SI units that are provided for information only and are not considered standard.

1.4 *This standard does not purport to address all of the safety concerns, if any, associated with its use. It is the responsibility of the user of this standard to establish appropriate safety and health practices and determine the applicability of regulatory limitations prior to use.*

2. Referenced Documents

2.1 ASTM Standards:²

A29/A29M Specification for General Requirements for Steel Bars, Carbon and Alloy, Hot-Wrought

A153/A153M Specification for Zinc Coating (Hot-Dip) on Iron and Steel Hardware

B633 Specification for Electrodeposited Coatings of Zinc on Iron and Steel

D3951 Practice for Commercial Packaging

2.2 AWS Standards:³

AWS A5.1 Covered Carbon Steel Arc Welding Electrodes

AWS A5.2 Iron and Steel Oxyfuel Gas Welding Rods

AWS A5.5 Low Alloy Steel Covered Arc Welding Electrodes

2.3 ANSI Standards:⁴

ANSI B1.1 Unified Inch Screw Threads (UN and UNR Thread Form)

ANSI B18.2.2 Square and Hex Nuts

2.4 Military Standards:⁵

MIL-STD-1186 Cushioning, Anchoring, Bracing, Blocking, and Waterproofing; with Appropriate Test Methods

MIL-STD-2073-1 DoD Material Procedures for Development and Application of Packaging Requirements

2.5 Military Specification:⁵

MIL-P-116 Preservation, Methods of

MIL-L-19140 Lumber and Plywood, Fire-Retardant Treated

2.6 Federal Specifications:⁴

PPP-B-636 Boxes, Shipping, Fiberboard

PPP-F-320 Fiberboard: Corrugated and Solid Sheet Stock (Container Grade) and Cut Shapes

2.7 Federal Standard:⁵

FED-STD-123 Marking for Shipment (Civil Agencies)

3. Classification

3.1 Turnbuckles covered under this specification shall be of the following types and grades, as specified (see 4.1.3 and 4.1.7):

3.1.1 *Type I*—Open turnbuckle bodies (see 5.2.4–5.2.7)

3.1.1.1 *Grade*:

(1) Forged

(2) Spread

(3) Resistance welded

(4) Arc or gas welded

3.1.2 *Type II*—Pipe turnbuckle bodies (see 5.2.8).

3.1.3 *Type III*—Rigging turnbuckle bodies (see 5.2.9).

3.2 Turnbuckles covered under this specification shall be of the following classes and sizes, as specified (see 4.1.3):

3.2.1 *Classes*:

A—turnbuckle, body only without end pulls, heads not drilled.

⁴ Available from American National Standards Institute (ANSI), 25 W. 43rd St., 4th Floor, New York, NY 10036, <http://www.ansi.org>.

⁵ Available from Standardization Documents Order Desk, DODSSP, Bldg. 4, Section D, 700 Robbins Ave., Philadelphia, PA 19111-5098, <http://dodssp.daps.dla.mil>.

¹ This specification is under the jurisdiction of ASTM Committee F25 on Ships and Marine Technology and is the direct responsibility of Subcommittee F25.07 on General Requirements.

Current edition approved May 1, 2011. Published May 2011. Originally approved in 1988. Last previous edition approved in 2005 as F1145–05. DOI: 10.1520/F1145-05R11.

² For referenced ASTM standards, visit the ASTM website, www.astm.org, or contact ASTM Customer Service at service@astm.org. For *Annual Book of ASTM Standards* volume information, refer to the standard's Document Summary page on the ASTM website.

³ Available from American Welding Society (AWS), 550 NW LeJeune Rd., Miami, FL 33126, <http://www.aws.org>.

B—turnbuckle, body only without end pulls, heads threaded right and left hand.

C—turnbuckle with stub and stub end pulls, complete.

D—turnbuckle with eye and eye end pulls, complete.

E—turnbuckle with hook and hook end pulls, complete.

F—turnbuckle with hook and eye end pulls, complete.

G—turnbuckle with jaw and jaw end pulls, complete.

H—turnbuckle with jaw and eye end pulls, complete.

3.2.1.1 The arrangement of turnbuckle bodies and end pulls for Classes C, D, E, F, G, and H shall be similar to Fig. 1.

3.2.2 Sizes—Shall be as listed in Table 1 and Table 2.

4. Ordering Information

4.1 Orders for material under this specification shall include the following information:

4.1.1 ASTM designation and year of issue,

4.1.2 Quantity required,

4.1.3 Type, class, and size (see 3.1, 3.2, and 8.1),

4.1.4 Material, if different (see 5.1.1),

4.1.5 Type thread required (see 7.3),

4.1.6 Type finish required (see 9.3),

4.1.7 Grade required, if Type I is specified (see 3.1.1),

4.1.8 Optional requirements, if any (see S1 and S2).

TABLE 1 Turnbuckle Bodies, Classes A and B, and Turnbuckles, Class C

NOTE 1—1 in. = 25.4 mm.

Thread, Nominal Outside Diameter, in.	Size								
	Clear Opening Between Head, in.								
	4	4½	6	9	12	18	24	36	48
¼	X
5/16	...	X
3/8	X
½	X	X	X
5/8	X	X	X	X
¾	X	X	X	X	X
7/8	X	...	X	X	X
1	X	...	X	X	X	X	...
1¼	X	...	X	X	X	X	...
1⅜	X
1½	X	...	X	X	X	X	X
1¾	X	X	X	X	X
2	X	X	X	X
2¼	X	X	X	X
2½	X	X	X	X
2¾	X	X
3	X	X
3½	X	X
4	X	X

TABLE 2 Turnbuckles, Classes D, E, F, G, and H.

NOTE 1—1 in. = 25.4 mm

Thread, Nominal Outside Diameter, in.	Size								
	Clear Opening Between Heads, in.								
	4	4½	6	9	12	18	24	36	48
¼	X
5/16	...	X
3/8	X
½	X	X	X
5/8	X	X	X	X
¾	X	X	X	X	X
7/8	X	X	X
1	X	X	X	X	...
1¼	X	X	X	X	...
1½	X	X	X	X	X
1¾	X	X	X	X
2	X	X	X
2¼	X	X	X
2½	X	X	X

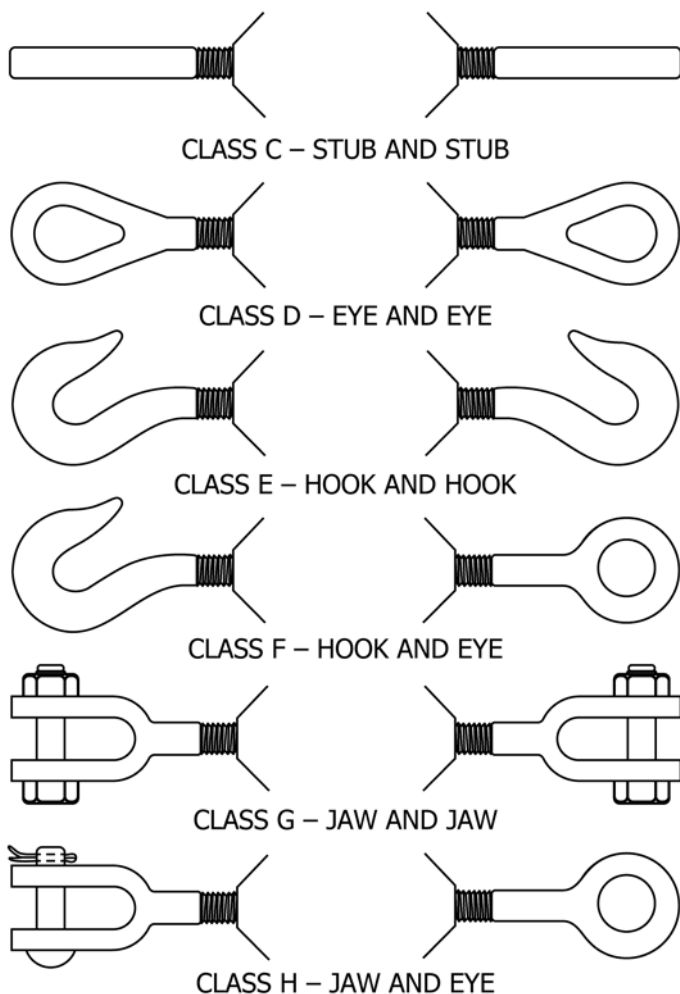

FIG. 1 Classes of Turnbuckles

5. Materials and Manufacture

5.1 Materials:

5.1.1 Unless otherwise specified (see 4.1.4), turnbuckle and end pulls shall be made from steel of a grade which will meet the requirements of Table 3.

5.1.2 For materials used for welded turnbuckle bodies, eye and jaw end pulls, the carbon shall be 0.25 % maximum, sulfur 0.05 % maximum, and phosphorus 0.05 % maximum.

5.1.3 Heavy jam nuts shall be right-hand or left-hand threaded, as required, and made of carbon steel of a type selected from Groups 1016 to 1020, inclusive in accordance with Specification A29/A29M.

TABLE 3 Breaking Strength of Turnbuckles (Complete With End Pulls)

NOTE 1—1 in. = 25.4 mm.

NOTE 2—1 lb = 0.45 kg.

Size, Nominal Outside Diameter of Thread, in.	Strength Breaking, min, lbf (kN)				Recommended Working Loads, lbf (kN)			
	Type I, Grade 1		All Others		Type I, Grade 1		All Others	
	Jaw, Eye, or Stub End Pulls	Hook End Pulls	Jaw, Eye, or Stub End Pulls	Hook End Pulls	Jaw, Eye, or Stub End Pulls	Hook End Pulls	Jaw, Eye, or Stub End Pulls	Hook End Pulls
1/4	2 500 (11)	1 500 (7)	1 550 (7)	1 050 (5)	500 (2)	300 (1.3)	310 (1.4)	210 (0.9)
5/16	3 500 (16)	2 500 (11)	2 700 (12)	1 650 (7.3)	700 (3)	500 (2.2)	540 (2.4)	330 (1.5)
3/8	5 200 (23)	3 500 (16)	4 100 (18)	2 300 (10)	1 040 (4.6)	700 (3.1)	820 (3.6)	460 (2)
1/2	9 000 (40)	5 200 (23)	7 550 (34)	3 700 (16.4)	1 800 (8)	1 040 (8)	1 500 (7)	740 (3.3)
5/8	13 500 (60)	8 000 (36)	12 100 (54)	5 400 (24)	2 700 (12)	1 600 (7.1)	2 400 (11)	1 080 (4.8)
3/4	20 000 (89)	10 000 (44)	18 100 (81)	7 500 (33)	4 000 (18)	2 000 (9)	3 600 (16)	1 500 (7)
7/8	29 000 (129)	12 000 (53)	25 100 (112)	10 000 (44)	5 800 (26)	2 400 (11)	5 000 (22)	2 000 (9)
1	38 000 (169)	14 500 (64)	33 100 (147)	12 800 (57)	7 600 (34)	2 900 (13)	6 600 (29)	2 560 (11.4)
1 1/4	60 000 (267)	23 000 (102)	53 600 (238)	20 600 (92)	12 000 (53)	4 600 (20)	10 700 (48)	4 120 (18.3)
1 3/8	72 000 (320)	29 000 (129)	63 400 (282)	24 300 (108)	14 400 (64)	5 800 (26)	12 600 (56)	4 860 (22)
1 1/2	85 000 (378)	36 000 (160)	77 700 (345)	29 300 (130)	17 000 (76)	7 200 (32)	15 500 (69)	5 860 (26.1)
1 3/4	115 000 (511)	...	105 000 (467)	...	23 000 (102)	...	21 000 (93)	...
2	150 000 (667)	...	138 000 (614)	...	30 000 (133)	...	27 600 (122)	...
2 1/4	197 000 (876)	...	181 000 (805)	...	39 400 (175)	...	36 200 (161)	...
2 1/2	242 000 (1076)	...	223 000 (992)	...	48 400 (215)	...	44 600 (198)	...
2 3/4	304 000 (1352)	...	277 000 (1232)	...	60 800 (270)	...	55 400 (246)	...
3	350 000 (1556)	...	337 000 (1499)	...	70 000 (311)	...	67 400 (300)	...
3 1/4	400 000 (1779)	...	400 000 (1779)	...	80 000 (356)	...	80 000 (356)	...
3 1/2	475 000 (2112)	...	475 000 (2113)	...	95 000 (423)	...	95 000 (423)	...
3 3/4	550 000 (2446)	...	550 000 (2446)	...	110 000 (489)	...	110 000 (489)	...
4	635 000 (2824)	...	635 000 (2824)	...	127 000 (565)	...	127 000 (565)	...

5.1.4 Jaw end pulls 5/8 in. (16 mm) and smaller shall be provided with a steel hexagon head bolt and nut of commercial quality. Jaw end pulls 3/4 in. (19 mm) and larger shall be provided with a round head steel pin and cotter of commercial value.

5.2 Manufacture:

5.2.1 Eye End Pulls—Eye end pulls shall be forged, resistance welded, or arc or gas welded, at the option of the producer, except that when forged bodies are specified, forged-eye end pulls shall be required.

5.2.1.1 Each forged-eye end pull shall be forged at elevated temperature to final shape and size and shall be similar to Fig. 2. The shape of the eye may be either oval or round.

5.2.1.2 Resistance-welded eye end pulls shall be similar to Fig. 3. They shall be fabricated from one piece of material by bending the material to form the eye and joined by resistance welding process.

5.2.1.3 Arc- or gas-welded eye end pulls shall be similar to Fig. 4. They shall be fabricated from one piece of material by bending the material to form the eye and joined by welding. The cross-sectional area through the weld shall be not less than the cross-sectional area of the bar.

5.2.2 Jaw End Pulls—Jaw end pulls shall be forged, arc or gas welded, or upset, at the option of the producer, except that if forged bodies are specified, forged-jaw end pulls shall be provided.

5.2.2.1 Forged-jaw end pulls shall be similar to Fig. 5.

5.2.2.2 Arc- or gas-welded end pulls shall be similar to Fig. 6.

5.2.2.3 Upset jaw end pulls shall be similar to Fig. 7.

5.2.3 Hook End Pulls—Hook end pulls shall be forged and be similar to Fig. 8.

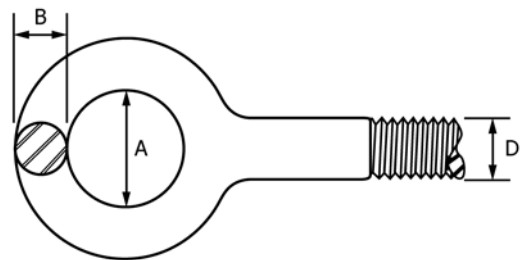
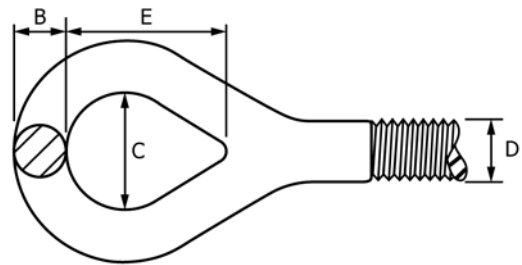

FIG. 2 Forged-Eye End Pull

5.2.4 Type I, Grade 1 Turnbuckles—Each forged turnbuckle body shall be forged at elevated temperature to final shape and size and shall be similar to Fig. 9. The shape of the head of the turnbuckle shall be either round or hexagonal.

5.2.5 Type I, Grade 2 Turnbuckles—For each spread turnbuckle body, one piece of material shall be cut lengthwise from near one end to the other end by any suitable means, such as an oxyacetylene cutting torch; the resulting reins shall then be spread apart at elevated temperatures to final shape and size.

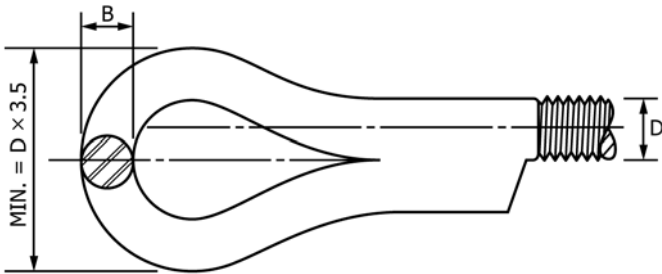

FIG. 3 Resistance-Welded-Eye End Pull

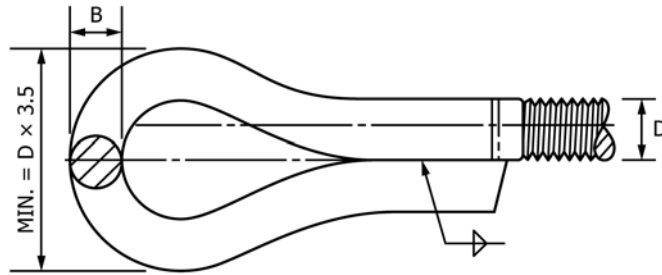

FIG. 4 Arc or Gas Welded-Eye End Pull

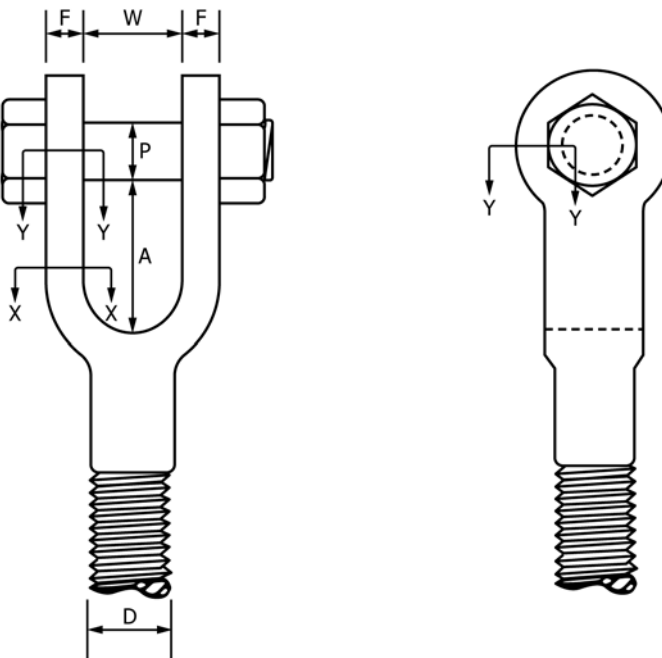

FIG. 5 Forged-Jaw End Pull

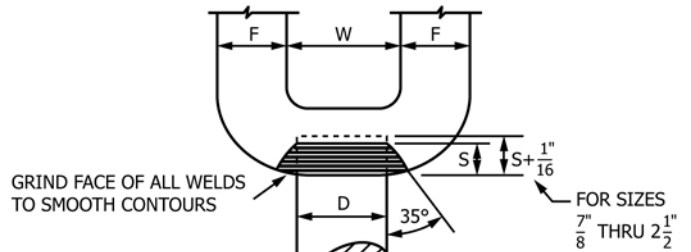
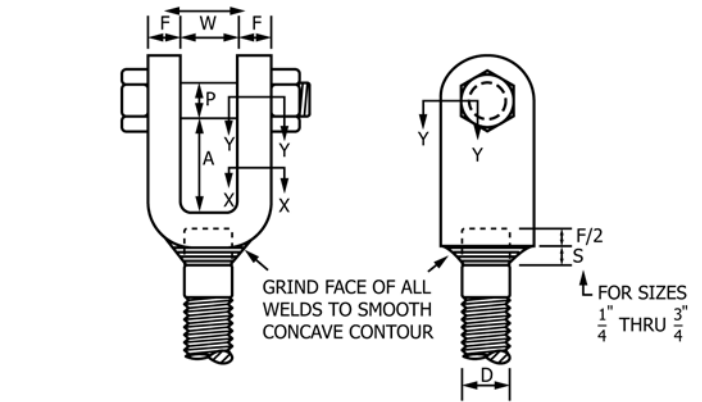

FIG. 6 Arc or Gas Welded-Jaw End Pull

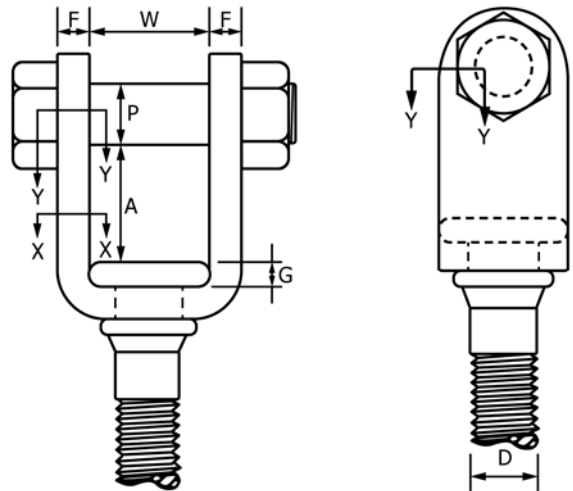

FIG. 7 Upset Jaw End Pull

The bodies shall be similar to Fig. 10. The shape of the cross section of the material shall be at the option of the producer.

5.2.6 *Type I, Grade 3 Turnbuckles*—Each resistance-welded turnbuckle body shall be fabricated by joining two formed pieces of material by either the flash or upset welding process. The welds shall be parallel to the long axis of the piece. The surfaces to be joined shall be held in intimate contact by external forces, an electric current passed through the surfaces, and the weld consolidated by the forces. The bodies shall be similar to Fig. 11. The shape of the cross section of the pieces shall be at the option of the producer.

5.2.7 *Type I, Grade 4 Turnbuckles*—The welds shall be either electric arc or oxyacetylene (gas) at the option of the producer. Arc- or gas-welded turnbuckle bodies shall be fabricated by joining four pieces of material by welds similar to Fig. 12. The faces of the welds shall not be concave but may be somewhat convex.

5.2.8 *Type II, Pipe*—Pipe turnbuckle bodies shall be forged, swaged, spun, drawn, or upset in way of the threaded ends, and shall be similar to Fig. 13.

5.2.9 *Type III, Rigging*—Rigging turnbuckle bodies shall be forged, similar to Fig. 14, and shall be provided with a heavy jam nut (see 5.1.3) of a type which does not depend upon deformation of the threads for security.

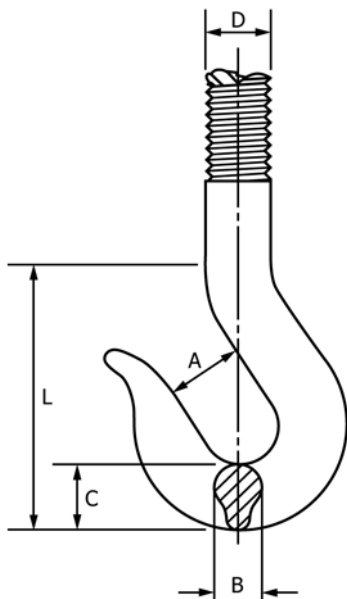

FIG. 8 Hook End Pull

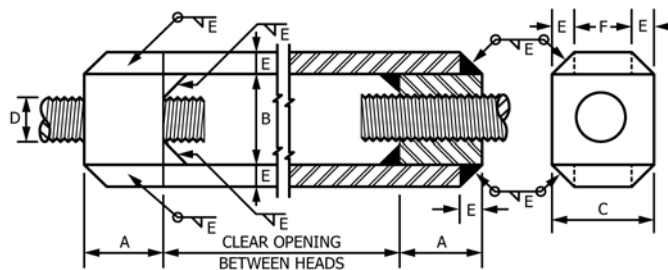

FIG. 12 Type I, Grade 4, Open Turnbuckle Body, Arc or Gas Welded

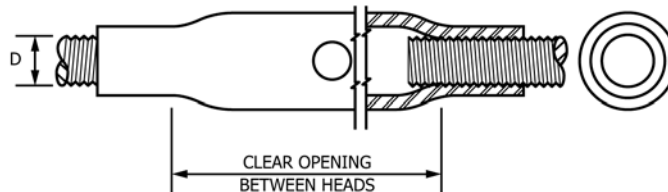

FIG. 13 Type II, Pipe Turnbuckle Body

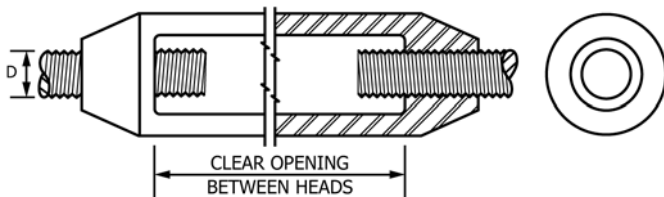

FIG. 9 Type I, Grade 1, Open Turnbuckle Body, Forged

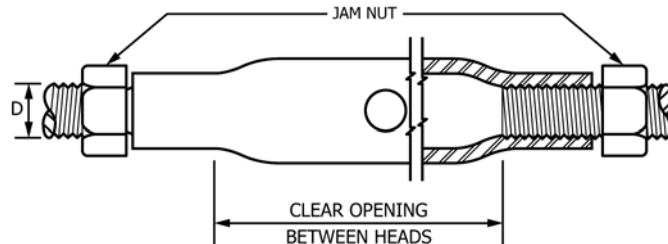

FIG. 14 Type III, Rigging Turnbuckle Body

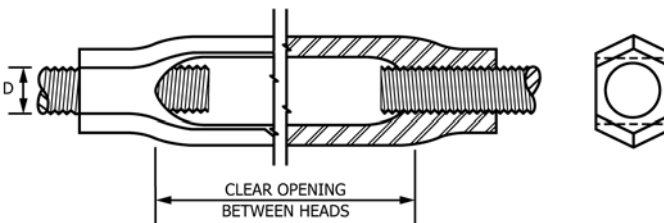

FIG. 10 Type I, Grade 2, Open Turnbuckle Body, Spread

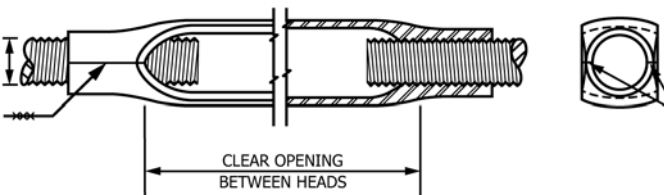

FIG. 11 Type I, Grade 3, Open Turnbuckle Body, Resistance Welded

6. Mechanical Properties

6.1 The breaking strength of turnbuckles, equipped with end pulls, shall be not less than the value given in Table 3 for the required size, type, and grade of end pull specified.

6.2 End pulls shall be capable of bending through an angle of 90° around a pin twice the nominal major diameter of the end pull without either crack or rupture.

6.3 End pulls for Classes D, E, F, G, and H shall be capable of supporting a load equal to one half of the specified breaking strength without permanent deformation.

7. Other Requirements

7.1 All arc-welded bodies, eyes, and jaws shall be welded with Type 7015, 7016, 8015, or 8016 electrodes of AWS A5.1 or AWS A5.5, as applicable.

7.2 All gas-welded bodies, eyes, and jaws shall be welded with welding rods in accordance with AWS A5.2.

7.3 Turnbuckle bodies and end pulls shall be threaded after fabrication to final size and shape. The threads in the heads of the turnbuckle bodies and on the end pulls shall comply with ANSI B1.1 (see 4.1.5). Unified threads in the coarse (UNC) and fine (UNF) standard series should be used. If neither is specified, the threads will be in the UNC series. If the standard diameter-pitch combinations are not suitable, the UNS threads with dimensions in accordance with ANSI B1.1 should be used.

7.3.1 Threads on the finished turnbuckle shall not be looser than class 1A/1B fit. If coated turnbuckles are specified, the male threads on the end pulls may be undercut, as necessary, so that after coating they will properly mate (not looser than 1A/1B fit) with the standard size female threads of the turnbuckle bodies.

7.3.2 The thread in one head of each turnbuckle body shall be right-hand and in the other head, left-hand.

7.3.3 The threads on the end pulls shall be right-hand on one end pull and left-hand on the other. The length of the thread on the two end pulls shall be great enough so that the ends of the end pull can be brought into contact with each other at the middle of the body length when jam nuts are not used.

8. Dimensions and Tolerances

8.1 Turnbuckles covered by this specification shall be furnished in the sizes shown in Table 1 and Table 2, as specified (see 4.1.3).

8.1.1 The size of turnbuckle bodies and turnbuckles shall be the nominal major diameter of the threads in the heads and the clear opening between heads (which is approximately equal to the take up); thus, for a 3/4 by 6-in. (19 by 152-mm) turnbuckle body, the heads shall be threaded for a 3/4-in. (19-mm) nominal major diameter end pull, and the clear opening between heads shall be 6 in. (152 mm). The difference between the actual clear opening in the turnbuckle body and the nominal value given in Table 1 or 2 for the size specified shall not exceed 5 % of the nominal value.

8.1.2 The lengths of the heads of the turnbuckle bodies shall not be less than 1 1/2 times the nominal outside diameter of the end pull for sizes up to 1 1/4 in. (32 mm), and 1 1/4 times for sizes 1 1/4 in. (32 mm) and above.

8.2 Type I, Grade 4 turnbuckle bodies shall comply with the dimensional requirements given in Table 4 for the size specified.

8.3 For Types II and III turnbuckle bodies, holes in body shall be 1/4 in. (6 mm) in diameter for sizes up to and including 5/8 in. (16 mm); holes in body for sizes larger than 5/8 in. (16 mm) shall be 1/2 in. (13 mm) in diameter (see Fig. 13 and Fig. 14, respectively).

8.4 Minimum dimensions for forged-eye end pulls are as shown in Table 5 (Figs. 2-4).

TABLE 5 Dimensions of Eye End Pulls, in. (mm)

D, Nominal, in.	A, min	B, min	C, min	E, min
1/4	1/2 (12.7)	7/32 (5.56)	11/32 (8.73)	11/16 (17.4)
5/16	5/8 (7.93)	9/32 (7.14)	7/16 (11.11)	13/16 (20.6)
3/8	3/4 (19)	11/32 (8.73)	17/32 (13.4)	15/16 (23.8)
1/2	1 (25.4)	7/16 (11.11)	23/32 (18.2)	13/16 (30.1)
5/8	1 1/4 (31.7)	1/2 (12.7)	7/8 (22.2)	13/8 (34.9)
3/4	1 1/2 (38.1)	5/8 (15.8)	1 (25.4)	15/8 (41.2)
7/8	1 3/4 (44.4)	3/4 (19)	1 1/4 (31.7)	17/8 (47.6)
1	2 (50.8)	7/8 (22.2)	1 1/16 (36.5)	2 1/4 (57.1)
1 1/4	2 1/8 (53.9)	1 1/16 (26.9)	1 1/16 (42.8)	2 3/16 (65)
1 1/2	2 1/4 (57.1)	1 1/4 (31.7)	2 1/8 (53.9)	3 1/4 (82.5)
1 3/4	2 1/2 (63.5)	1 7/16 (36.5)	2 3/8 (60.3)	3 3/4 (95.2)
2	3 (76.2)	1 5/8 (41.2)	2 11/16 (68.2)	4 3/8 (111.1)
2 1/4	3 1/4 (82.5)	1 13/16 (46)	2 15/16 (74.6)	5 3/16 (131.7)
2 1/2	3 1/2 (88.9)	2 (50.8)	3 1/8 (79.3)	6 (152.4)

8.5 For arc- or gas-welded and resistance-welded eye end pulls, the outside diameter of the eye shall be not less than 3 1/2 times the nominal diameter of the end pull. Nominal dimensions “D” and “B” (see Fig. 3 and Fig. 4) shall be in accordance with Table 5.

8.6 Forged-jaw end pulls shall comply with the dimensional requirements of Table 6 (Figs. 5-7).

8.6.1 In Fig. 5, the area of the cross section X-X shall be not less than 0.75 of the area corresponding to the nominal diameter. The area of the cross section Y-Y shall be not less than 0.40 of the area corresponding to the nominal diameter.

8.7 Arc- or gas-welded jaw end pulls shall comply with the dimensional requirements of Table 7 (Fig. 6).

8.7.1 In Fig. 6, the area of the cross section X-X shall be not less than 0.75 of the area corresponding to the nominal diameter. The area of the cross section Y-Y shall be not less than 0.40 of the area corresponding to the nominal diameter.

8.8 Upset jaw ends shall comply with the dimensional requirements of Table 8 (Fig. 7).

TABLE 4 Type I, Grade 4 Dimensions of Open Turnbuckle Bodies Fabricated by Arc or Gas Welding, in. (mm)

Size, D, Nominal, in.	Head			Rein		Size of All Fillet Welds, min
	Length, A, min	Thickness, B, min	Width, C, min	Thickness, E, min	Width, F, min	
1/4	7/16 (11.11)	1/2 (12.7)	9/16 (14.3)	1/8 (3.1)	5/16 (7.9)	1/8 (3.17)
5/16	5/8 (15.8)	1 1/16 (17.5)	13/16 (20.6)	3/16 (4.7)	7/16 (11.11)	3/16 (4.76)
3/8	1 1/16 (17.5)	3/4 (19)	7/8 (22.2)	3/16 (4.7)	1/2 (12.7)	3/16 (4.76)
1/2	7/8 (22.2)	1 (25.4)	1 1/8 (28.6)	1/4 (6.35)	5/8 (15.8)	1/4 (6.35)
5/8	1 1/8 (28.6)	1 1/4 (31.7)	1 7/16 (36.5)	5/16 (7.9)	13/16 (20.6)	5/16 (7.93)
3/4	1 3/8 (34.9)	1 1/2 (38.1)	1 3/4 (44.4)	3/8 (9.5)	1 (25.4)	3/8 (9.52)
7/8	1 5/8 (39.7)	1 3/4 (44.4)	2 (50.8)	7/16 (11.11)	1 1/8 (28.5)	7/16 (11.11)
1	1 3/4 (44.4)	2 (51)	2 1/4 (57.1)	1/2 (12.7)	1 1/4 (31.7)	1/2 (12.7)
1 1/4	2 1/8 (54)	2 1/2 (63.5)	2 3/4 (70)	5/8 (15.8)	1 1/2 (38.1)	5/8 (15.8)
1 3/8	2 3/8 (60.3)	2 3/4 (70)	3 1/16 (77.7)	1 1/16 (17.4)	1 11/16 (42.8)	1 1/16 (17.4)
1 1/2	2 5/8 (65.1)	3 (76.2)	3 5/16 (84.1)	3/4 (19.05)	1 13/16 (46)	3/4 (19.05)
1 3/4	2 13/16 (71.4)	3 3/8 (85.7)	3 5/8 (92.1)	13/16 (20.6)	2 (50.8)	13/16 (20.6)
2	3 3/16 (81)	3 7/8 (98.4)	4 1/8 (104.8)	1 5/16 (23.8)	2 1/4 (57.1)	1 5/16 (23.8)
2 1/4	3 1/2 (89)	4 1/4 (108)	4 1/2 (114.3)	1 (25.4)	2 1/2 (63.5)	1 (25.4)
2 1/2	3 15/16 (100)	4 3/4 (120.6)	5 1/16 (128.6)	1 1/8 (28.5)	2 13/16 (71.4)	1 1/8 (28.5)
2 3/4	4 3/8 (111)	5 1/4 (133.4)	5 5/8 (142.9)	1 1/4 (31.7)	3 1/8 (79.3)	1 1/4 (31.7)
3	4 13/16 (122)	5 3/4 (146)	6 3/16 (157.2)	1 3/8 (34.9)	3 7/16 (87.3)	1 3/8 (34.9)
3 1/2	5 5/16 (141)	6 3/4 (171.5)	7 3/16 (182.5)	1 5/8 (41.2)	3 5/16 (100)	1 5/8 (41.2)
4	6 5/16 (160)	7 5/8 (193.7)	8 1/8 (206.3)	1 13/16 (46)	4 1/2 (114.3)	1 13/16 (46)

TABLE 6 Dimensions of Forged-Jaw End Pulls, in. (mm)

D, Nominal, in.	A, min	F, min	P, min	W, min
1/4	5/8 (15.8)	1/8 (3.17)	1/4 (6.35)	3/8 (9.52)
5/16	23/32 (18.2)	1/8 (3.17)	1/4 (6.35)	15/32 (11.9)
3/8	13/16 (20.6)	3/16 (4.76)	5/16 (7.93)	1/2 (12.7)
1/2	1 1/32 (26.1)	1/4 (6.35)	3/8 (9.52)	5/8 (15.8)
5/8	1 1/4 (31.7)	5/16 (7.93)	1/2 (12.7)	3/4 (19)
3/4	1 1/2 (38.1)	3/8 (9.52)	5/8 (15.8)	15/16 (23.8)
7/8	1 3/4 (44.4)	7/16 (11.11)	3/4 (19)	1 1/8 (28.5)
1	2 (50.8)	1/2 (12.7)	7/8 (22.2)	1 3/16 (30.1)
1 1/4	2 3/8 (60.3)	5/8 (15.8)	1 1/8 (28.5)	1 3/4 (44.4)
1 1/2	2 3/4 (69.8)	11/16 (17.4)	1 3/8 (34.9)	2 1/16 (52.3)
1 3/4	3 (76.2)	3/4 (19)	1 5/8 (41.2)	2 3/8 (60.3)
2	3 3/4 (95.2)	13/16 (20.6)	1 7/8 (47.6)	2 1/2 (63.5)
2 1/4	4 (101.6)	7/8 (22.2)	2 1/16 (52.3)	2 5/8 (66.6)
2 1/2	4 1/4 (107.9)	1 (25.4)	2 1/4 (57.1)	2 7/8 (73)

8.8.1 In Fig. 7, the area of the cross section X-X shall be not less than 0.75 of the area corresponding to the nominal diameter. The area of the cross section Y-Y shall be not less than 0.40 of the area corresponding to the nominal diameter.

8.9 Hook end pulls shall comply with the dimensional requirements of Table 9 (Fig. 8).

8.10 Heavy jam nuts (see 5.1.3) shall conform to the dimensional requirements in accordance with ANSI B18.2.2.

9. Workmanship, Finish, and Appearance

9.1 Turnbuckles and end pulls shall be finished in a workmanlike manner. All parts shall be properly shaped and shall be free from fins, cracks, flaws, seams, and other injurious defects.

9.1.1 Screw threads shall be true to form, clean cut, and free from injurious defects.

9.2 Turnbuckles and end pulls shall be finished by grinding the flash and excess weld metal smooth, where required, and the loose scale removed.

9.3 Turnbuckles shall be furnished self-colored, black, or zinc-coated, as specified (see 4.1.6).

9.3.1 If zinc-coated turnbuckles are specified, the coating may be applied by the hot-dip (galvanizing) process or the electrodeposition process at the manufacturer's option.

9.3.1.1 If the hot-dip process is used, the coating shall be applied in accordance with Specification A153/A153M and shall be adherent, smooth, and free from injurious lumps, blisters, dross, or flux.

9.3.1.2 If the electrodeposition process is used, it shall conform to Type II finish, Class Fe/Zn 12 in accordance with Specification B633.

9.3.2 Coating shall be done on the end pulls after threading; coating for turnbuckle bodies shall be done after tapping.

10. Sampling

10.1 All turnbuckles of the same type, grade, class, and size, not exceeding 1000 and presented at one time, shall be considered a lot.

10.2 A random sample of turnbuckles shall be selected from each lot in accordance with Table 10 for the examination specified in 12.2.

10.3 A random sample of turnbuckles shall be selected from each lot in accordance with Table 11 for the breaking strength, proof, bending, and galvanizing tests specified in Section 11.

10.3.1 End pull samples for bending tests shall be selected prior to threading.

10.3.2 Failure of any sample in any test shall be cause for rejection of the lot represented by the sample.

10.3.3 Specimens used for the breaking strength and bend tests may also be used for the galvanizing tests.

11. Test Methods

11.1 *Proof Test*—Each sample selected in accordance with 10.3 shall be subjected to a proof test of one half the specified breaking strength (see Table 11) for the end pull. Test loads shall be applied at end pulls.

11.2 *Breaking Strength Test*—Each sample turnbuckle selected in accordance with 10.3 shall be tested to failure. Loads shall be applied at end pulls.

11.3 *Bending Test*—Each end pull sample selected in accordance with 10.3 shall be bent cold through an angle of 90° around a pin twice the nominal diameter of the end pull.

11.4 *Galvanizing Test*—If the hot-dip zinc-coating method is used, no thickness test will be required. If the electrodeposition method is used, the thickness shall be determined as specified in Specification B633.

11.5 Possible test failures are defined as follows:

11.5.1 *Proof Test*—Evidence of deformation or signs of incipient cracks in turnbuckle body or end pull as a result of specified proof test.

11.5.2 *Breaking Strength Test*—Breaking strength or turnbuckles equipped with end pulls less than the required minimum value.

11.5.3 *Bending Test*—Evidence of cracks or rupture when the unthreaded end pull is bent cold as required.

11.5.4 *Galvanizing Test*—Coating nonconformant; nonadherent, evidence of coat flaking off, or separating from basic metal; thickness less than the allowable minimum.

12. Inspection

12.1 The purchaser reserves the right to perform any of the inspections set forth in the specification where such inspections are deemed necessary to ensure that supplies and services conform to prescribed requirements.

12.2 Each sample turnbuckle selected in accordance with Table 10 shall be examined to verify compliance with the requirements of this specification. Examination shall be conducted as specified in Table 12.

12.2.1 Any turnbuckle in the sample containing one or more defects shall be rejected. If any defects are noted in the original sample units, an additional sample quantity, in accordance with Table 10, shall be randomly selected; and if any defects are noted as specified in Table 12, this shall be cause for rejection of the lot represented by that sample.

13. Rejection and Rehearing

13.1 Material that fails to conform to the requirements of this specification may be rejected. Rejection should be reported

TABLE 7 Dimensions of Arc or Gas Welded-Jaw End Pulls, in. (mm)

D, Nominal Size, in.	A, min		F, min		P, min		S, min		W, min	
1/4	5/8	(15.8)	1/4	(6.35)	1/4	(6.35)	3/16	(4.76)	3/8	(9.52)
5/16	23/32	(18.2)	1/4	(6.35)	1/4	(6.35)	3/16	(4.76)	15/32	(11.9)
3/8	13/16	(20.6)	5/16	(7.93)	5/16	(7.93)	3/16	(4.76)	1/2	(12.7)
1/2	11/32	(26.1)	3/8	(9.52)	3/8	(9.52)	3/16	(4.76)	5/8	(15.8)
5/8	1 1/4	(31.7)	1/2	(12.7)	1/2	(12.7)	1/4	(6.35)	3/4	(19)
3/4	1 1/2	(38.1)	9/16	(14.3)	5/8	(15.8)	5/16	(7.93)	15/16	(23.8)
7/8	1 3/4	(44.4)	11/16	(17.4)	3/4	(19)	3/8	(9.52)	1 1/8	(28.5)
1	2	(50.8)	3/4	(19)	7/8	(22.2)	3/8	(9.52)	1 3/16	(30.1)
1 1/4	2 3/8	(60.3)	7/8	(22.2)	1 1/8	(28.5)	7/16	(11.1)	1 3/4	(44.4)
1 1/2	2 3/4	(69.8)	1 1/8	(28.6)	1 3/8	(34.9)	1/2	(12.7)	2 1/16	(52.3)
1 3/4	3	(76.2)	1 1/4	(31.7)	1 5/8	(41.2)	5/8	(15.8)	2 3/8	(60.3)
2	3 3/4	(95.2)	1 1/2	(38.1)	1 7/8	(47.6)	1 1/16	(17.4)	2 1/2	(63.5)
2 1/4	4	(101.6)	1 1/2	(38.1)	2 1/16	(52.3)	3/4	(19)	2 5/8	(66.6)
2 1/2	4 1/4	(107.9)	1 9/16	(39.6)	2 1/4	(56.2)	1 3/16	(20.6)	2 7/8	(73)

TABLE 8 Dimensions of Upset End Pulls, in. (mm)

D, Nominal, in.	A, min		F, min		G, min		P, min		W, min	
1/4	1/2	(12.7)	1/8	(3.2)	1/8	(3.2)	1/4	(6.35)	1/2	(12.7)
3/8	11/16	(17.4)	3/16	(4.76)	5/32	(4)	3/8	(9.5)	3/4	(19)
1/2	1	(25.4)	1/4	(6.35)	3/16	(4.76)	1/2	(12.7)	1	(25.4)
5/8	1 1/4	(31.7)	5/16	(7.9)	1/4	(6.35)	5/8	(15.9)	1 1/32	(29.4)
3/4	1 7/16	(36.5)	3/8	(9.5)	5/16	(7.9)	3/4	(19)	1 5/16	(33.3)
7/8	1 11/16	(42.8)	7/16	(11.1)	3/8	(9.5)	7/8	(22.2)	1 1/2	(38.1)
1	1 7/8	(47.6)	1/2	(12.7)	7/16	(11.1)	1	(25.4)	1 3/4	(44.4)
1 1/4	2 3/8	(60.3)	5/8	(15.9)	1/2	(12.7)	1 1/4	(31.7)	2 5/16	(58.7)
1 1/2	2 7/8	(73)	1 1/16	(17.4)	9/16	(14.3)	1 1/2	(38.1)	2 5/8	(66.6)
1 3/4	3 3/8	(85.7)	3/4	(19)	5/8	(15.9)	1 3/4	(44.4)	3 1/16	(77.7)
2	3 7/8	(98.4)	1 3/16	(20.6)	1 1/16	(17.4)	2	(50.8)	3 1/2	(88.9)
2 1/4	4 3/8	(111.1)	7/8	(22.2)	3/4	(19)	2 1/4	(57.1)	3 15/16	(100)
2 1/2	4 7/8	(123.8)	1	(25.4)	1 3/16	(23.8)	2 1/2	(63.5)	4 3/8	(111.1)

TABLE 9 Dimensions of Hook End Pulls, in. (mm)

D, Nominal, in.	A, min		B, min		C, min		L, min	
1/4	7/16	(11.1)	3/16	(4.76)	11/32	(8.73)	1	(25.4)
5/16	1/2	(12.7)	1/4	(6.35)	7/16	(11.1)	1 1/4	(31.7)
3/8	9/16	(14.3)	11/32	(8.73)	7/16	(11.1)	1 9/16	(39.6)
1/2	5/8	(15.8)	7/16	(11.1)	5/8	(15.6)	2	(50.8)
5/8	13/16	(20.6)	17/32	(13.4)	3/4	(19)	2 7/16	(61.9)
3/4	1 1/32	(24.6)	5/8	(15.8)	15/16	(23.8)	2 15/16	(74.6)
7/8	1 1/8	(28.5)	3/4	(19)	1	(25.4)	3 7/16	(87.3)
1	1 1/4	(31.7)	15/16	(23.8)	1 3/16	(30.2)	3 7/8	(98.4)
1 1/4	1 1/2	(38.1)	1	(25.4)	1 7/16	(36.5)	4 15/16	(125.4)
1 1/2	1 7/8	(47.6)	1 3/16	(30.2)	1 3/4	(44.4)	5 7/8	(149.2)

TABLE 10 Sampling for Examination

Number of Turnbuckles in Lot	Number of Turnbuckles in Sample
40 or under	10
41 to 110	15
111 to 300	25
301 to 500	35
501 to 800	50
801 to 1000	75

TABLE 11 Sampling for Tests

Number of Turnbuckles in Lot	Number of Samples to be Selected for:		
	Proof	Breaking Strength and Galvanizing	Bend and Galvanizing
40 and under	3	1	1
41 to 110	5	1	1
111 to 300	7	2	2
301 to 500	10	3	3
501 to 1000	15	5	5

to the producer or supplier promptly and in writing. In case of dissatisfaction with the results of the test, the producer or supplier may make claim for a reheating.

14. Packaging and Package Marking

14.1 Unless otherwise specified (see 4.1.8), packaging shall conform to the manufacturer's normal commercial practice, and in such a manner that will ensure acceptance by common carrier and afford protection against physical and mechanical damage during shipment. Shipping containers shall conform to carrier regulations as applicable to the mode of transportation.

15. Keywords

15.1 forged turnbuckles; open turnbuckle body; pipe turnbuckle body; rigging turnbuckle body; swaged turnbuckle; turnbuckle; welded turnbuckle



TABLE 12 Defects

Defects
Type and size not as specified.
Material not as specified; surface not smooth, evidence of scale, fins, cracks, flaws, and scams.
End pulls or locknuts, missing, damaged, or fail to mate as required.
Shape of the head of the body not as required.
Clear opening between heads not within specified tolerance.
Head length of body less than the required minimum.
Thread length of end pulls less than required.
Screw threads nonconforming; not right- or left-hand as required, size and pitch not as specified, pitch, major and minor diameters not within requirements, threads not square or concentric, form not true or clean cut, threads stripped, crossed, chipped, or damaged.
Shape and dimensions of end pulls not as specified, parts missing, incomplete, or damaged.
Surface not free from burrs, sharp edges, or loose scale; not free from rust or corrosion.
Zinc coating when applicable, nonconforming, not adherent, not uniform or smooth, not free from uncoated spots, injurious lumps, blisters, dross, or flux; not coated after threading.
Marking of packages not as specified.
Packaging and packing not as required.

SUPPLEMENTARY REQUIREMENTS

The following supplementary requirements shall apply only for direct government acquisition, when specified in the contract or order (see 4.1.8).

S1. General

S1.1 Navy Fire-Retardant Requirements:

S1.1.1 Treated Lumber and Plywood—When specified, all lumber and plywood including laminated veneer material used in shipping container and pallet construction, members, blocking, bracing, and reinforcing shall be fire-retardant treated material conforming to MIL-L-19140 as follows:

Levels A and B	Type II	Weather Resistant: Category I—General Use
Level C	Type I	Non-Weather Resistant: Category I—General Use

S1.1.2 Fiberboard—Fiberboard used in the construction of interior (unit and intermediate) and exterior fiberboard boxes, including interior packaging forms shall conform to the class domestic/fire retardant or class weather resistant/fire retardant materials requirements as specified in PPP-F-320 and amendments thereto.

S1.1.3 Cushioning and Wrapping Materials—The use of excelsior, newspaper, shredded paper (all types), and similar hydroscopic or non-neutral materials and all types of loose fill materials for packaging applications such as cushioning, fill, stuffing, and dunnage is prohibited. Material selected for cushioning and wrapping shall have properties (characteristics) for resistance to fire. Cushioning or wrapping materials, as applicable, shall be provided to prevent item and package damage and to prevent free movement of the container contents.

S2. Preservation

S2.1 Preservation shall be Level A or commercial as specified.

S2.1.1 Level A—Turnbuckles except black coated and zinc coated, shall be preserved in accordance with Method I of MIL-P-116, using type P-1 or P-19 preservative. Black coated or zinc coated turnbuckles shall be preserved in accordance with Method III of MIL-P-116.

S2.1.1.1 Turnbuckles with a mass less than 5 lb (2.5 kg) each shall be packed in fiberboard boxes conforming to PPP-B-636, class weather resistant. Box closure shall conform to Method V as specified in the applicable box specification appendix. The gross mass of the boxes shall not exceed the limitations of the applicable box specification.

S2.1.1.2 Turnbuckles with a mass over 5 lb (2.5 kg) each shall be bulk packed in containers specified in Section S3.

S2.2 Commercial—Turnbuckles shall be preserved in accordance with Practice D3951.

S3. Packing

S3.1 Packing shall be level A, B, C, or commercial as specified.

S3.1.1 General Requirements for Levels A, B, and C—Containers selected (see S3.1.2) shall be of minimum mass and cube consistent with the protection required, of uniform size, and contain identical quantities.

S3.1.2 Levels A, B, and C—Turnbuckles preserved as specified, shall be packed in exterior shipping containers in accordance with MIL-STD-2073-1, Table VII of Appendix C, for the level of packing specified. Unless otherwise specified container selection including container options shall be the contractor’s option.

S3.1.2.1 Closure, Gross Mass, and Waterproofing:

(1) *Closure*—Container closure, reinforcing, or banding shall be in accordance with container specification or appendix thereto except that weather resistant fiberboard boxes shall be closed in accordance with Method V and reinforced with nonmetallic or tape banding and domestic nonweather-resistant fiberboard boxes shall be closed in accordance with Method I using pressure-sensitive tape.

(2) *Mass*—Wood, plywood, and wood cleated type containers whose mass exceeds 200 lb (90 kg) shall be modified by the addition of skids in accordance with MIL-STD-2073-1, Appendix F or the applicable container specification or appendix thereto.

(3) *Waterproofing*—Unless otherwise specified, Level A and when specified Level B shipping containers shall be provided with case liners, linings, wraps, or shrouds in accordance with the waterproofing requirements of MIL-STD-1186.

S3.1.3 *Commercial*—Turnbuckles preserved as specified shall be packed for shipment in accordance with Practice **D3951** and herein.

S3.1.3.1 *Container Modification*—Shipping containers with mass exceeding 200 lb (90 kg) shall be provided with a minimum of two 3 by 4 in. (75 by 100 mm) nominal wood skids laid flat, or a skid or sill-type base which will support the material and facilitate handling by mechanical handling equipment during shipment, stowage and storage.

S4. Palletized Unit Loads

S4.1 When specified, containers shall be palletized in accordance with MIL-STD 2073-1, Appendix F.

S5. Marking

S5.1 *Levels A, B, C, and Commercial*—In addition to any special marking required, interior (unit) packs, shipping containers, and palletized unit loads shall be marked in accordance with MIL-STD 2073-1, Appendix F for military agencies and FED-STD 123 for civil agencies and shall include bar codes and applicable packaging acquisition options herein as specified.

ASTM International takes no position respecting the validity of any patent rights asserted in connection with any item mentioned in this standard. Users of this standard are expressly advised that determination of the validity of any such patent rights, and the risk of infringement of such rights, are entirely their own responsibility.

This standard is subject to revision at any time by the responsible technical committee and must be reviewed every five years and if not revised, either reapproved or withdrawn. Your comments are invited either for revision of this standard or for additional standards and should be addressed to ASTM International Headquarters. Your comments will receive careful consideration at a meeting of the responsible technical committee, which you may attend. If you feel that your comments have not received a fair hearing you should make your views known to the ASTM Committee on Standards, at the address shown below.

This standard is copyrighted by ASTM International, 100 Barr Harbor Drive, PO Box C700, West Conshohocken, PA 19428-2959, United States. Individual reprints (single or multiple copies) of this standard may be obtained by contacting ASTM at the above address or at 610-832-9585 (phone), 610-832-9555 (fax), or service@astm.org (e-mail); or through the ASTM website (www.astm.org). Permission rights to photocopy the standard may also be secured from the Copyright Clearance Center, 222 Rosewood Drive, Danvers, MA 01923, Tel: (978) 646-2600; <http://www.copyright.com/>