



Standard Specification for Warping Heads, Rope Handling (Gypsy Head, Capstan Head)¹

This standard is issued under the fixed designation F1106; the number immediately following the designation indicates the year of original adoption or, in the case of revision, the year of last revision. A number in parentheses indicates the year of last reapproval. A superscript epsilon (ϵ) indicates an editorial change since the last revision or reapproval.

1. Scope

1.1 This specification covers warping heads used with windlass, winch, and capstan drive units to pull rope on board ships. Warping heads are primarily for use with fiber rope, natural, or synthetic.

1.2 Warping heads with external ribs or whelps on the barrel, notched flanges, attached storage drums, unfinished drums, or non heat-treated fabrications, are considered special and are permitted within the scope of this specification when fully described under special ordering information.

1.3 The values stated in inch-pound units are to be regarded as the standard. The values given in parentheses are for information only.

2. Referenced Documents

2.1 ASTM Standards:²

[A27/A27M Specification for Steel Castings, Carbon, for General Application](#)

[A36/A36M Specification for Carbon Structural Steel](#)

[A53/A53M Specification for Pipe, Steel, Black and Hot-Dipped, Zinc-Coated, Welded and Seamless](#)

[A148/A148M Specification for Steel Castings, High Strength, for Structural Purposes](#)

[A501 Specification for Hot-Formed Welded and Seamless Carbon Steel Structural Tubing](#)

[A724/A724M Specification for Pressure Vessel Plates, Carbon-Manganese-Silicon Steel, Quenched and Tempered, for Welded Pressure Vessels](#)

[A735/A735M Specification for Pressure Vessel Plates, Low-Carbon Manganese-Molybdenum-Columbium Alloy Steel, for Moderate and Lower Temperature Service](#)

[E10 Test Method for Brinell Hardness of Metallic Materials](#)

2.2 AWS Standard:

[D 1.1 Structural Welding Code³](#)

2.3 ANSI Standard:

[ASA B 46.1 Surface Texture⁴](#)

2.4 Military Standards:

[Fed-Spec T-R-605 Manila, Three Strand⁵](#)

[MIL-R-24050 Nylon, Double Braided⁵](#)

3. Definitions of Terms Specific to This Standard

3.1 *barrel*—cylindrical or conical midbody portion of a warping head.

3.1.1 *Discussion*—The barrel may have a uniform diameter through the length or may be tapered from one end to the other.

3.2 *flanges*—circumferential rims at the ends of the barrel used to retain wraps of rope on the barrel portion of the warping head.

3.3 *rope contact surfaces*—portions of the barrel, flanges, and connecting fillets that a rope will contact when led in tangent to the barrel and normal to the shaft centerline, wrapped around the barrel, and led away tangent to the barrel as in normal use. (See [Fig. 1](#) and [Fig. 2](#).)

3.4 *warping head (also known as a gypsy head or capstan head)*—cylindrical or conical rotating member to receive multiple wraps of rope around the circumference of the member and of suitable strength to impart a pulling motion to the rope by friction contact when the member is rotated.

4. Classification

4.1 The size of the warping head shall be identified by the nominal barrel diameter measured at the smallest point of the barrel.

4.2 Warping heads under this specification are furnished in two types as follows:

³ Available from American Welding Society, 550 N.W. Le Jeune Rd., Miami, FL 33126.

⁴ Available from American National Standards Institute (ANSI), 25 W. 43rd St., 4th Floor, New York, NY 10036.

⁵ Available from Superintendent of Documents, U.S. Government Printing Office, Washington, DC 20402.

¹ This specification is under the jurisdiction of ASTM Committee F25 on Ships and Marine Technology and is the direct responsibility of Subcommittee F25.03 on Outfitting and Deck Machinery.

Current edition approved Oct. 1, 2012. Published October 2012. Originally approved in 1987. Last previous edition approved in 2006 as F1106 – 87 (2006). DOI: 10.1520/F1106-87R12.

² For referenced ASTM standards, visit the ASTM website, www.astm.org, or contact ASTM Customer Service at service@astm.org. For *Annual Book of ASTM Standards* volume information, refer to the standard's Document Summary page on the ASTM website.

 **F1106 – 87 (2012)**

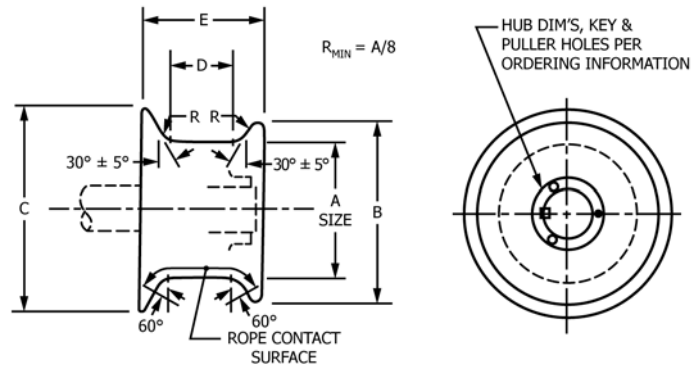

A Diameter, in.	Rope Pull, 1000 lb	B Diameter, in.	C Diameter, in.	D Length, in.	E Length, in.	Tolerance, in. \pm^A	Concentricity, in. ^B
6	12.5	8	9 ¹ / ₁₆	2 ³ / ₄	5 ¹⁵ / ₃₂	1/4	1/8
9	25.0	12	13 ⁹ / ₁₆	4 ¹ / ₁₆	8 ³ / ₁₆	3/8	3/16
12	37.5	16	18 ³ / ₁₆	5 ⁷ / ₁₆	10 ³¹ / ₃₂		
15	50.0	20	22 ³ / ₄	6 ³ / ₄	13 ¹¹ / ₁₆	1/2	1/4
18	75.0	24	27 ⁹ / ₁₆	8 ¹ / ₁₆	16 ¹³ / ₃₂		
21	100.0	28	31 ⁷ / ₈	9 ⁷ / ₁₆	19 ⁹ / ₁₆	5/8	5/16
24	125.0	32	36 ⁹ / ₈	10 ¹³ / ₁₆	21 ⁷ / ₈		
27	150.0	36	41 ¹⁵ / ₁₆	12 ³ / ₁₆	24 ³¹ / ₃₂	3/4	3/8
30	175.0	40	45 ¹ / ₂	13 ¹ / ₂	27 ³ / ₈		
33	200.0	44	50 ¹ / ₁₆	14 ¹³ / ₁₆	30 ⁹ / ₃₂	7/8	7/16
36	225.0	48	54 ⁵ / ₈	16 ³ / ₁₆	32 ⁷ / ₈		

^A Tolerance for dimensions A, B, C, D, and E.

^B Concentricity of rope contact surface and flanges relative to bore.

NOTE 1—1 in. = 25.4 mm.

FIG. 1 Type I Warping Head

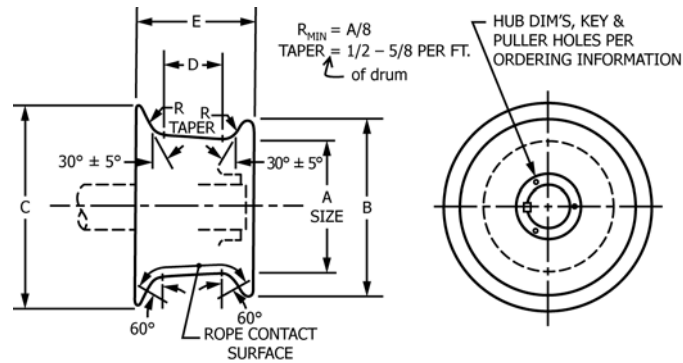

A Diameter, in.	Rope Pull, 1000 lb	B Diameter, in.	C Diameter, in.	D Length, in.	E Length, in.	Tolerance, in. \pm^A	Concentricity, in. ^B
6	12.5	8	9 ¹ / ₄	2 ³ / ₄	5 ¹⁵ / ₃₂	1/4	1/8
9	25.0	12	13 ¹⁵ / ₁₆	4 ¹ / ₁₆	8 ³ / ₁₆	3/8	3/16
12	37.5	16	18 ⁵ / ₈	5 ⁷ / ₁₆	10 ³¹ / ₃₂		
15	50.0	20	23 ¹ / ₄	6 ³ / ₄	13 ¹¹ / ₁₆	1/2	1/4
18	75.0	24	27 ⁷ / ₈	8 ¹ / ₁₆	16 ¹³ / ₃₂		
21	100.0	28	32 ⁹ / ₁₆	9 ⁷ / ₁₆	19 ⁹ / ₁₆	5/8	5/16
24	125.0	32	37 ⁹ / ₁₆	10 ¹³ / ₁₆	21 ⁷ / ₈		
27	150.0	36	41 ⁷ / ₈	12 ³ / ₁₆	24 ³¹ / ₃₂	3/4	3/8
30	175.0	40	46 ¹ / ₂	13 ¹ / ₂	27 ³ / ₈		
33	200.0	44	51 ¹ / ₈	14 ¹³ / ₁₆	30 ⁹ / ₃₂	7/8	7/16
36	225.0	48	55 ¹³ / ₁₆	16 ³ / ₁₆	32 ⁷ / ₈		

^A Tolerance for dimensions A, B, C, D, and E.

^B Concentricity of rope contact surface and flanges relative to bore.

NOTE 1—1 in. = 25.4 mm.

FIG. 2 Type II Warping Head

4.2.1 *Type I Warping Head With Cylindrical Barrel*—Generally used in but not restricted to horizontal shaft applications. Also known as a gypsy head (see Fig. 1).

4.2.2 *Type II Warping Head With a Conical Barrel*—Mounted with the large end of the barrel toward the drive machinery. Generally used in but not restricted to vertical shaft applications. Also known as a capstan head (see Fig. 2).

4.3 Warping heads are divided into four grades as follows:

4.3.1 *Grade 1*—Fabricated from any combination of structural steel plate, pipe, tubing, or steel castings and joined by electric welding.

4.3.2 *Grade 2*—Cast from mild to medium strength steel.

4.3.3 *Grade 3*—Fabricated from any combination of steel plate or steel castings and joined by electric welding. Heat treated to provide a surface hardness ($\frac{1}{8}$ in. (3 mm) deep) of 200 to 250 Brinell on rope contact surface. Rope contact surface finished to an average 125- to 160- μ m. (3175- to 4064- μ m) finish.

4.3.4 *Grade 4*—Cast from high strength steel castings and heat treated to provide a surface hardness ($\frac{1}{8}$ in. (3 mm) deep) of 200 to 250 Brinell on rope contact surface. Rope contact surface finished to an average 125- to 160- μ m. (3175- to 4064- μ m) finish.

4.4 When required by ordering information, an accessory cover will be provided to cover the open end of the warping head.

5. Ordering Information

5.1 Orders for warping heads under this specification shall include the following:

5.1.1 Quantity (number),

5.1.2 ASTM designation and year of issue,

5.1.3 Size (barrel diameter),

5.1.4 Type (I or II),

5.1.5 Grade (1, 2, 3, or 4),

5.1.6 As-cast or machined dimensions for warping head bore, hub length and location, hub puller holes, and shaft keying,

5.1.7 Requirement for optional accessory cover on open end of warping head (see 4.4),

5.1.8 Special features required (ribs or whelps on barrel, notched flanges, and attached storage drums), and

5.1.9 Product marking (shipping).

6. Material and Manufacture

6.1 Material for Grade 1 warping heads shall conform to Specification **A36/A36M** or Specification **A27/A27M** for barrel, flanges, hubs, and structural webs or diaphragms. Materials conforming to Specifications **A53/A53M** or **A501** may be used as an alternate for the barrel. Component parts may be formed by rolling or flanging, and joined by electric welding in accordance with ASW D1.1. Warping head weldment shall be stress relieved.

6.2 Material for Grade 2 warping heads shall conform to Specification **A27/A27M** annealed.

6.3 Material for Grade 3 warping heads shall conform to Specifications **A148/A148M**, **A724/A724M** Grade B, or Speci-

fication **A735/A735M** Class 4. Component parts may be formed by casting, rolling or flanging, and joined by electric welding, in accordance with AWS D1.1. Warping head weldment shall be stress relieved and heat treated for a surface hardness ($\frac{1}{8}$ in. (3 mm) deep) of 200 to 250 Brinell on rope contact surface, in accordance with hardness Test Method **E10**. Rope contact surfaces shall be finished in accordance with 8.7.

6.4 Material for Grade 4 warping heads shall conform to Specification **A148/A148M** quenched and tempered for a surface hardness ($\frac{1}{8}$ in. (3 mm) deep) of 200 to 250 Brinell on rope contact surface in accordance with hardness Test Method **E10**. Rope contact surfaces shall be finished in accordance with 8.7.

6.5 The manufacturer's name or identification mark, ASTM specification number, and pattern, part, or drawing number shall be cast molded or die stamped on the warping head, using minimum $\frac{1}{2}$ -in. (13-mm) size characters. The marking shall not be on the rope contact surface and shall be readily available for identification on an assembled windlass, winch, or capstan.

6.6 Structural webs and diaphragms between the hub and barrel shall completely seal and void internal portions of the warping head against the entry of water or provide complete self-drainage and maintenance access to internal portions. When present, voids shall be treated with preservative or primer paint.

6.7 An accessory cover, when required by the purchase order, shall be provided to cover the open end of the warping head opposite the drive shaft. Material shall be cast or wrought, steel or bronze. The cover shall be flat or domed and attached with corrosion-resistant fasteners (brass or monel), without projections that could snag or cut a slack rope and with provision for locking to prevent loosening under vibration. When the cover forms a void, a gasket shall be provided to seal against the entry of water.

7. Dimensions, Mass, and Permissible Variations

7.1 Principal dimensions, tolerances, and strength requirements for Types I and II are shown in Fig. 1 and Fig. 2, respectively. These requirements are considered standard and will govern unless special features are required and described (see 5.1.8).

7.2 Commonly acceptable warping head sizes for various fiber ropes are shown in Table 1 for general guidance only. The use of five wraps when using manila fiber rope is accepted practice. Some synthetic fiber ropes, because of reduced friction, require additional wraps. The equivalent sizes of synthetic fiber ropes shown in Table 1 are reduced on the basis of breaking strength and provide additional space on the barrel for increased wraps.

7.3 The strength of the barrel, flanges, webs, and diaphragms shall withstand the maximum rope pull shown in Fig. 1 and Fig. 2, applied tangent to the barrel, normal to the shaft, at the midpoint of the barrel, and wrapped around the barrel, with the combined stress not exceeding 75 % of the tensile yield point of the material. Compressive forces on the barrel, torsional shear forces between hub and barrel, and the wedging

TABLE 1 Warping Head Size and Suggested Rope Size

NOTE 1—The following table is provided for guidance subject to variations in breaking strengths and friction characteristics of specific ropes. Breaking strengths of ropes used should not exceed the maximum rope pull shown for the warping head size selected.

NOTE 2—Other rope constructions and materials are not listed in the absence of recognized standard breaking values.

NOTE 3—1 in. = 25.4 mm.

Warping Head Size, Diameter, in.	Rope Pull, Maximum, 1000 lb	Manila Rope Size, Circular, in. ^A	Nylon Rope Size, Circular, in. ^B
6	12.5	5/8 –2	3/4 –2
9	25.0	2 1/4 –3	2 1/4 –2 3/4
12	37.5	3 1/4 –4	3 –3 1/2
15	50.0	4 1/2 –5	3 3/4 –4
18	75.0	5 1/2 –6	4 1/2 –5
21	100.0	6 1/2 –7	5 1/2
24	125.0	7 1/2 –8	6 –6 1/2
27	150.0	8 1/2 –9	7
30	175.0	10	7 1/2
33	200.0	11	8
36	225.0	12	8 1/2 –9

^A Manila, three strand, Fed-Spec T-R-605.

^B Nylon, double braided, MIL-R-24050.

forces against the flanges, shall be considered. This requirement does not imply a similar requirement for drive horsepower or brake capacity in the drive unit.

8. Workmanship, Finish, and Appearance

8.1 Welds shall be extended around ends of members and be free of pockets and irregularities that would tend to trap water.

8.2 Welds shall be ground flush to match the surrounding surface in areas of rope contact.

8.3 Component parts, formed by rolling or flanging, shall be visually examined during fabrication to ensure freedom from cracks.

8.4 Castings shall be smooth, of fine grain, and free of cracks, hot tears, and blow holes, detrimental to end use.

8.5 Castings shall have all flash material, vents, and gates removed and ground flush to match the surrounding surfaces.

8.6 Weldments and castings shall be free of sharp edges and burrs that could cut or snag fiber rope coming in contact with any accessible portion of the rotating warping head.

8.7 Rope contact surfaces of Grades 3 and 4 warping heads shall be finished to an average surface roughness of 125 to 160 $\mu\text{in.}$ (3175 to 4064 μmm) in accordance with ANSI Standard ASA B46.1.

NOTE 1—Local flaws (holes) no larger than 3/16 in. (4.7 mm) in diameter are acceptable when they have no sharp edges or burrs that would cut fiber rope, providing the total area of flaws (holes) does not exceed 5 % of the total rope contact surface.

8.8 Weldments and castings shall be cleaned by sand blasting, shot blast, or equivalent methods to remove all loose scale or slag.

9. Inspection

9.1 The completed warping head shall be visually inspected for workmanship, dimensions, surface hardness (when applicable), finish and appearance, after cleaning.

10. Product Marking

10.1 *Shipping*—Each warping head, when furnished as a separate component, shall be marked with the ASTM standard designation, type and grade, purchase order, and item number. Product marking shall be by paint or weatherproof tag.

11. Packaging and Package Marking

11.1 Warping heads, when furnished as a separate component, shall be crated, skidded, or attached to a pallet in a manner acceptable for handling by common carrier. When warping head is furnished with machined bore or hub, machined surfaces shall be protected against corrosion in open weather storage for a period of at least one year.

12. Keywords

12.1 berthing ship; capstan drive units; capstan head; capstan windlass; gypsyhead; mooring ship; rope handling; warping head winch; warping ship; windlass

ASTM International takes no position respecting the validity of any patent rights asserted in connection with any item mentioned in this standard. Users of this standard are expressly advised that determination of the validity of any such patent rights, and the risk of infringement of such rights, are entirely their own responsibility.

This standard is subject to revision at any time by the responsible technical committee and must be reviewed every five years and if not revised, either reapproved or withdrawn. Your comments are invited either for revision of this standard or for additional standards and should be addressed to ASTM International Headquarters. Your comments will receive careful consideration at a meeting of the responsible technical committee, which you may attend. If you feel that your comments have not received a fair hearing you should make your views known to the ASTM Committee on Standards, at the address shown below.

This standard is copyrighted by ASTM International, 100 Barr Harbor Drive, PO Box C700, West Conshohocken, PA 19428-2959, United States. Individual reprints (single or multiple copies) of this standard may be obtained by contacting ASTM at the above address or at 610-832-9585 (phone), 610-832-9555 (fax), or service@astm.org (e-mail); or through the ASTM website (www.astm.org). Permission rights to photocopy the standard may also be secured from the Copyright Clearance Center, 222 Rosewood Drive, Danvers, MA 01923, Tel: (978) 646-2600; http://www.copyright.com/