



Standard Specification for Envelope Dimensions for Butterfly Valves—NPS 2 to 24¹

This standard is issued under the fixed designation F1098; the number immediately following the designation indicates the year of original adoption or, in the case of revision, the year of last revision. A number in parentheses indicates the year of last reapproval. A superscript epsilon (ϵ) indicates an editorial change since the last revision or reapproval.

1. Scope

1.1 This specification provides standard dimensions for manual (lever and gear actuator) butterfly valves installed in shipboard piping systems in NPS 2 to NPS 24, inclusive.

1.2 This specification covers conventional and ANSI B16.34 class butterfly valves of both lug and wafer types.

1.3 The values stated in inch-pound units are to be regarded as standard. The values given in parentheses are mathematical conversions to SI units that are provided for information only and are not considered standard.

2. Referenced Documents

2.1 *ANSI Standard*:²

B 16.34 Small Butt Welding End Valves

¹ This specification is under the jurisdiction of ASTM Committee F25 on Ships and Marine Technology and is the direct responsibility of Subcommittee F25.11 on Machinery and Piping Systems.

Current edition approved May 1, 2015. Published June 2015. Originally approved in 1987. Last previous edition approved in 2010 as F1098 – 87 (2010). DOI: 10.1520/F1098-87R15.

² Available from American National Standards Institute (ANSI), 25 W. 43rd St., 4th Floor, New York, NY 10036, <http://www.ansi.org>.

3. Dimensions

3.1 *Face-to-Face Dimensions*:

3.1.1 Valve body face-to-face dimensions are provided in **Table 1**.

3.1.2 The face-to-face dimensions are the metal-to-metal dimensions between the valve body flange faces that require separate gaskets or the compressed or installed condition for valves using liners that extend from the body contact faces and act as flange gaskets.

3.2 *Actuator Dimensions*:

3.2.1 The maximum permissible dimensions for lever- and gear-type actuators are provided in **Fig. 1**.

3.2.2 The handwheel and handle may be on either side of the valve.

3.2.3 All handwheels and handles rotate clockwise to close the valve.

4. Tolerances

4.1 *Face-to-Face Dimensions*—A plus or minus tolerance of $\frac{1}{16}$ in. (1.6 mm) for all sizes shall be allowed (see **Table 1**).

5. Keywords

5.1 envelope dimensions; gear actuator butterfly valves; lever butterfly valves; manual butterfly valves

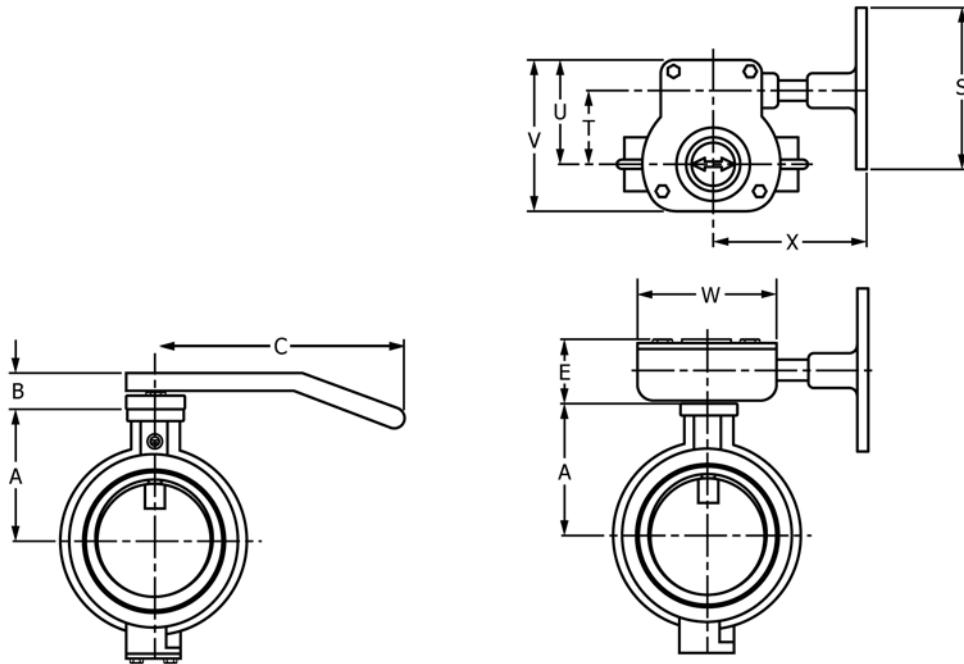

NOTE 1—1 in. = 25.4 mm

Dimensions, in.	Valve Size—NPS													
	2	2.5	3	4	5	6	8	10	12	14	16	18	20	24
A	8.00	9.00	10.00	10.00	11.00	11.00	12.00	14.00	17.00	19.00	21.00	23.00	25.00	27.00
B	3.00	3.00	3.50	3.50	3.50	4.00	4.00	4.00	4.00					
C	15.00	15.00	15.00	15.00	15.00	15.00	24.00	24.00	24.00					
E	4.00	4.00	5.50	5.50	5.50	5.50	5.50	6.00	6.00	8.00	8.00	9.00	9.00	10.00
S	12.00	12.00	12.00	12.00	12.00	12.00	12.00	12.00	12.00	24.00	24.00	24.00	24.00	24.00
T	2.50	2.50	2.50	2.50	2.50	3.50	3.50	6.50	6.50	6.50	6.50	6.50	6.50	6.50
U	4.00	4.00	4.00	4.00	4.00	4.00	4.00	5.00	5.00	8.00	8.00	8.00	8.00	9.50
V	6.50	6.50	6.50	6.50	6.50	6.50	6.50	8.50	8.50	10.50	10.50	11.50	12.00	13.50
W	5.00	5.00	5.00	5.00	5.00	5.00	6.00	7.00	7.50	9.00	9.00	11.00	11.00	11.50
X	9.50	9.50	9.50	9.50	9.50	9.50	9.50	10.50	13.00	13.00	14.50	14.50	20.00	20.00

FIG. 1 Actuator Envelope Dimensions

TABLE 1 Face-to-Face Dimensions

Valve Size, NPS	Conventional, 200 psig, in. (mm)	ANSI B16.34, 150 Class, in. (mm)
2	1 ⁵ / ₈ (41)	1 ³ / ₄ (44)
2 ¹ / ₂	1 ³ / ₄ (44)	1 ⁷ / ₈ (48)
3	1 ³ / ₄ (44)	1 ⁷ / ₈ (48)
3 ¹ / ₂	1 ¹⁵ / ₁₆ (49)	2 (51)
4	2 (51)	2 ¹ / ₈ (54)
5	2 ¹ / ₁₆ (52)	2 ¹ / ₄ (57)
6	2 ¹ / ₈ (54)	2 ¹ / ₄ (57)
8	2 ⁷ / ₁₆ (62)	2 ¹ / ₂ (64)
10	2 ⁹ / ₁₆ (65)	2 ¹³ / ₁₆ (71)
12	3 (76)	3 ³ / ₁₆ (81)
14	3 ¹ / ₁₆ (93)	3 ⁵ / ₈ (92)
16	4 ¹ / ₁₆ (103)	4 (102)
18	4 ⁹ / ₁₆ (116)	4 ¹ / ₂ (114)
20	5 ¹ / ₁₆ (128)	5 (127)
24	5 ⁷ / ₈ (149)	6 ¹ / ₁₆ (154)

 **F1098 – 87 (2015)**

ASTM International takes no position respecting the validity of any patent rights asserted in connection with any item mentioned in this standard. Users of this standard are expressly advised that determination of the validity of any such patent rights, and the risk of infringement of such rights, are entirely their own responsibility.

This standard is subject to revision at any time by the responsible technical committee and must be reviewed every five years and if not revised, either reapproved or withdrawn. Your comments are invited either for revision of this standard or for additional standards and should be addressed to ASTM International Headquarters. Your comments will receive careful consideration at a meeting of the responsible technical committee, which you may attend. If you feel that your comments have not received a fair hearing you should make your views known to the ASTM Committee on Standards, at the address shown below.

This standard is copyrighted by ASTM International, 100 Barr Harbor Drive, PO Box C700, West Conshohocken, PA 19428-2959, United States. Individual reprints (single or multiple copies) of this standard may be obtained by contacting ASTM at the above address or at 610-832-9585 (phone), 610-832-9555 (fax), or service@astm.org (e-mail); or through the ASTM website (www.astm.org). Permission rights to photocopy the standard may also be secured from the Copyright Clearance Center, 222 Rosewood Drive, Danvers, MA 01923, Tel: (978) 646-2600; <http://www.copyright.com/>