



# Standard Practice for Use of Rubber-Cord Pie Disk to Demonstrate the Discernment Capability of a Tire X-ray Imaging System<sup>1</sup>

This standard is issued under the fixed designation F1035; the number immediately following the designation indicates the year of original adoption or, in the case of revision, the year of last revision. A number in parentheses indicates the year of last reapproval. A superscript epsilon ( $\epsilon$ ) indicates an editorial change since the last revision or reapproval.

## 1. Scope

1.1 This practice describes the construction and use of a rubber-cord pie-shaped standard disk for demonstrating the discernment capability of an X-ray imaging system.

1.2 This practice is applicable to direct viewing (fluoroscopic) X-ray imaging systems and film, plate or paper (radiographic) X-ray imaging systems that are used for checking the construction consistency of pneumatic tires.

1.3 The values stated in SI units are to be regarded as the standard.

1.4 *This standard does not purport to address the safety concerns associated with its use. It is the responsibility of the user of this standard to establish appropriate safety and health practices and determine the applicability of regulatory limitations prior to use.*

## 2. Referenced Documents

2.1 *ASTM Standards:*<sup>2</sup>

[D1349 Practice for Rubber—Standard Conditions for Testing](#)

[D3186 Test Methods for Rubber—Evaluation of SBR \(Styrene-Butadiene Rubber\) Mixed With Carbon Black or Carbon Black and Oil](#)

[F538 Terminology Relating to the Characteristics and Performance of Tires](#)

## 3. Terminology

3.1 *Definitions:*

3.1.1 *pie disk, rubber-cord, n— in tire X-ray testing*, a circular disk of a specified diameter having six pie-shaped sections, each containing cord of different materials; it is used

<sup>1</sup> This practice is under the jurisdiction of ASTM Committee F09 on Tires and is the direct responsibility of Subcommittee F09.10 on Equipment, Facilities and Calibration.

Current edition approved June 1, 2015. Published September 2015. Originally approved in 1986. Last previous edition approved in 2008 as F1035 – 03 (2008). DOI: 10.1520/F1035-03R15.

<sup>2</sup> For referenced ASTM standards, visit the ASTM website, [www.astm.org](http://www.astm.org), or contact ASTM Customer Service at [service@astm.org](mailto:service@astm.org). For *Annual Book of ASTM Standards* volume information, refer to the standard's Document Summary page on the ASTM website.

for demonstrating the discernment capability of an X-ray imaging system. **(F538)**

3.1.2 *X-ray image plane, n— in tire testing*, a surface located at a specified distance from the X-ray tube “focal spot.”

3.1.2.1 *Discussion*—The centerline of the cone of radiation from the X-ray tube is normal to the image plane. **F538**

3.1.3 *X-ray imaging system, n— in tire testing*, a collection of the components and subsystems needed to produce a fluoroscopic or radiographic image of the tire.

3.1.3.1 *Discussion*—The collection includes the X-ray high voltage generator, X-ray tube, and X-ray screen or radiograph. **F538**

3.1.4 *X-ray radiograph, n—*an X-ray film, plate, or paper that is placed at the image plane and is used for recording an X-ray image of the object being examined. **F538**

3.1.5 *X-ray screen, n—*a fluorescent screen, placed at the image plane, that produces an X-ray image of the object being examined.

3.1.5.1 *Discussion*—This visible light may be photographed or input to a television system. **F538**

## 4. Summary of Practice

4.1 The pie disk is a rubber-cord composite that is used as the subject in an X-ray imaging system. Each of the six sections of the disk has a different cord material which, together, represent the cords commonly used in vehicle tires. The X-ray absorption of these cords range from very nearly the same as that of the rubber matrix to quite different from it.

4.2 The rubber-cord pie disk shall be placed between the X-ray tube and the X-ray image plane at a specified distance from the image plane (see Fig. 1). The ambient conditions are controlled or monitored, and recorded.

4.3 The image of the disk on a fluorescent screen or photograph can be studied for clarity of detail for each cord material. The voltage and current of the X-ray high voltage generator shall be adjusted for optimum detail and contrast sensitivity to view all cord materials simultaneously.

## 5. Significance and Use

5.1 All X-ray systems are subject to changing efficiencies, so a practice for checking the overall operation is needed. This

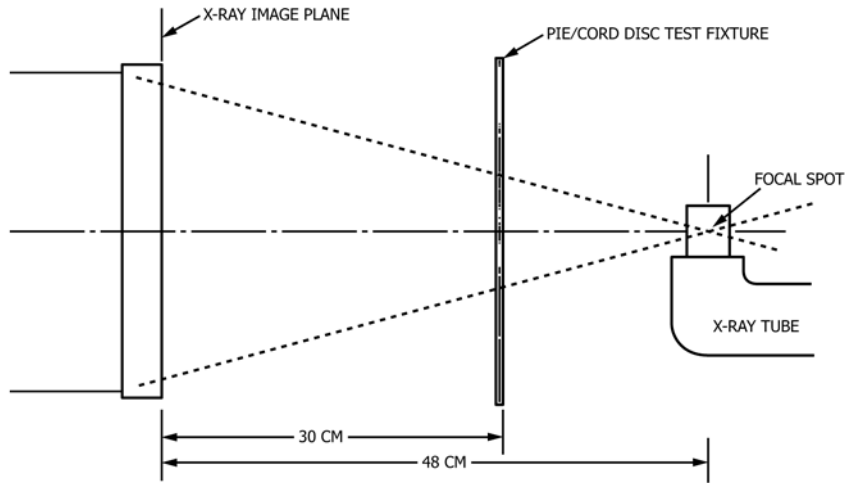

FIG. 1 Pie-Cord Disk Test Fixture Positioning for Tire X-Ray System

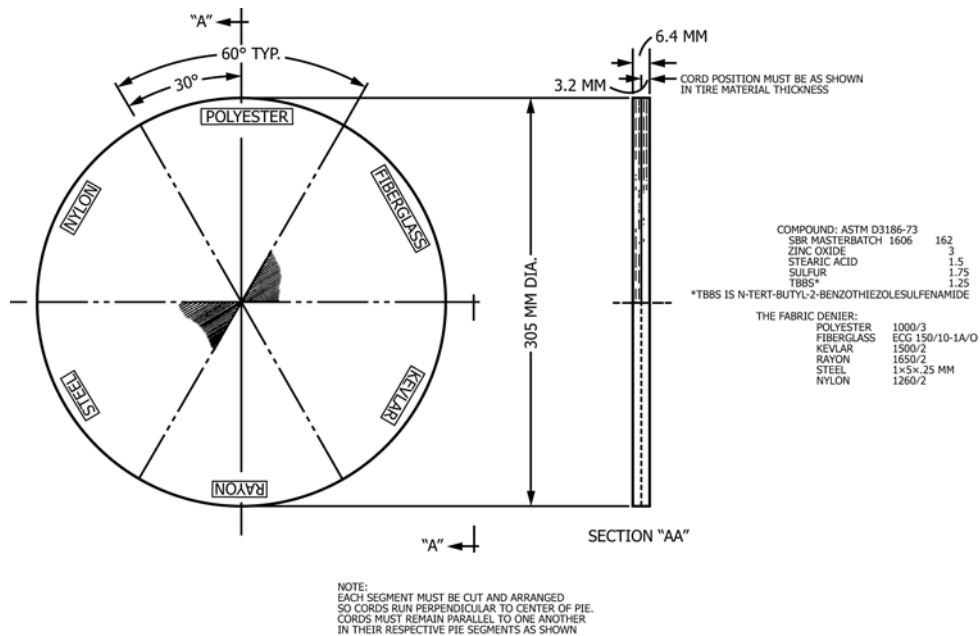

FIG. 2 Pie-Cord Disk Test Fixture

practice will assure the operator of an optimized image when ambient conditions are controlled and the X-ray high voltage generator is adjusted as prescribed.

5.2 The densities of some tire cord materials are very close to that of the rubber matrix in which they are enclosed, so the resolving capability of an X-ray system is critical to the detection of abnormalities. The rubber-cord pie disk provides a means for optimizing the resolving power in a particular apparatus and for comparing its performance over any period of time.

5.3 The rubber-cord pie disk can be used to compare the performances of X-ray systems in different laboratories. It can also be used in special cases to optimize system performance

for a particular sector or cord-type, as may be required for examining a specific tire.

## 6. Preparation of Rubber-Cord Pie Disk<sup>3</sup>

### 6.1 Composition:

6.1.1 The disk shall have six equal-size sectors of rubber-cord composite, as given in Fig. 2. The rubber portion of each has a composition based on Test Methods D3186, using

<sup>3</sup> The sole source of supply of the rubber-cord pie disk known to the committee at this time is Zephyr Technology, Inc., P.O. Box 2691, Bath, OH 44210. If you are aware of alternative suppliers, please provide this information to ASTM International Headquarters. Your comments will receive careful consideration at a meeting of the responsible technical committee<sup>1</sup>, which you may attend.



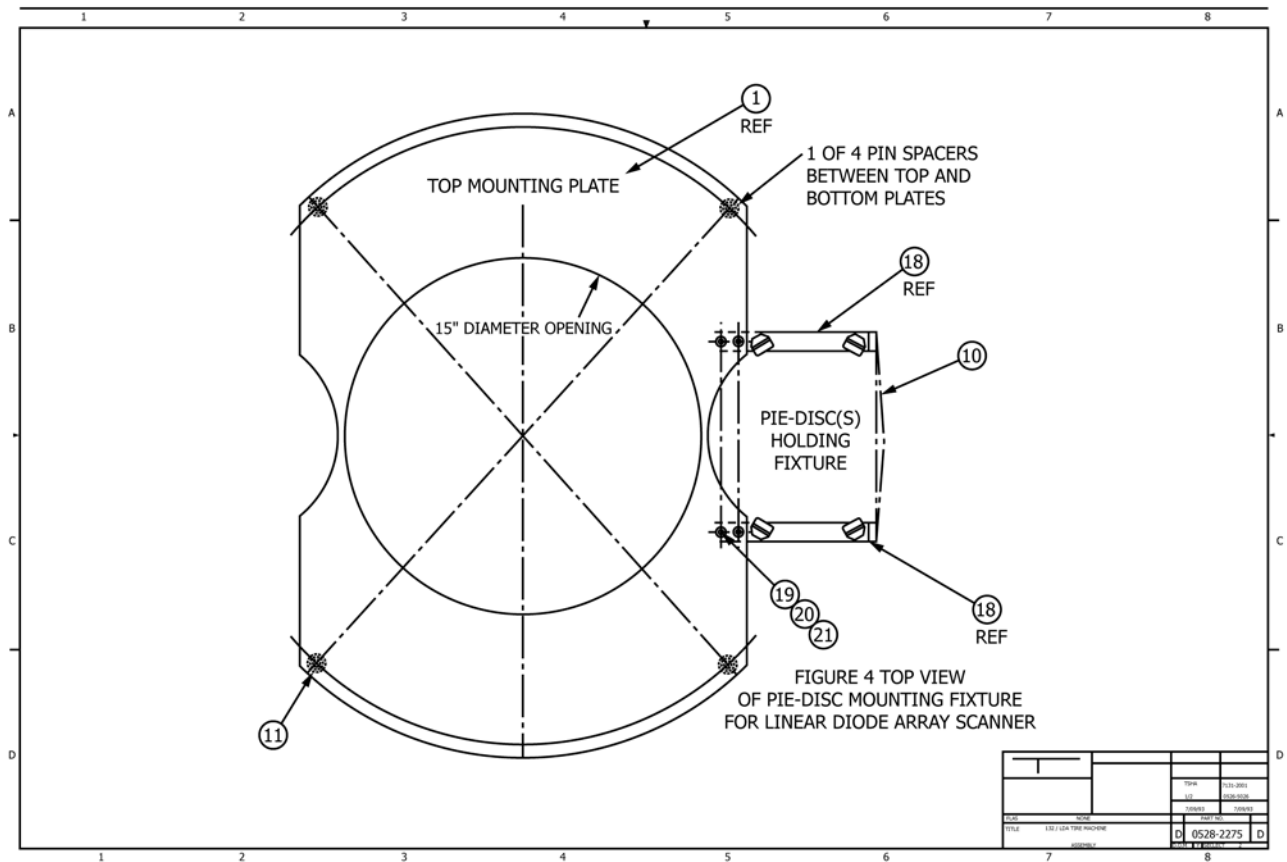

FIG. 4 Top View of Pie Disk Mounting Fixture for Linear Diode Array Scanner

8.2 The ambient temperature and line voltage are monitored and recorded. The ambient temperature and line voltage must be controlled in order to duplicate a previous calibration test.

8.3 The X-ray image of the rubber-cord pie disk is viewed by the operator. The voltage and current of the X-ray high voltage generator shall be adjusted for optimum detail and contrast sensitivity to view all cord materials simultaneously.

**9. Precision and Bias**

9.1 Precision and bias are not pertinent to this practice since it gives procedures for the optimum adjustment of an X-ray system. No measurements are made.

**10. Keywords**

10.1 rubber-cord pie disk; X-ray; X-ray image plane; X-ray radiograph

*ASTM International takes no position respecting the validity of any patent rights asserted in connection with any item mentioned in this standard. Users of this standard are expressly advised that determination of the validity of any such patent rights, and the risk of infringement of such rights, are entirely their own responsibility.*

*This standard is subject to revision at any time by the responsible technical committee and must be reviewed every five years and if not revised, either reapproved or withdrawn. Your comments are invited either for revision of this standard or for additional standards and should be addressed to ASTM International Headquarters. Your comments will receive careful consideration at a meeting of the responsible technical committee, which you may attend. If you feel that your comments have not received a fair hearing you should make your views known to the ASTM Committee on Standards, at the address shown below.*

*This standard is copyrighted by ASTM International, 100 Barr Harbor Drive, PO Box C700, West Conshohocken, PA 19428-2959, United States. Individual reprints (single or multiple copies) of this standard may be obtained by contacting ASTM at the above address or at 610-832-9585 (phone), 610-832-9555 (fax), or service@astm.org (e-mail); or through the ASTM website (www.astm.org). Permission rights to photocopy the standard may also be secured from the Copyright Clearance Center, 222 Rosewood Drive, Danvers, MA 01923, Tel: (978) 646-2600; http://www.copyright.com/*