



Standard Guide for Field Measurements of Airborne Sound Attenuation of Building Facades and Facade Elements¹

This standard is issued under the fixed designation E966; the number immediately following the designation indicates the year of original adoption or, in the case of revision, the year of last revision. A number in parentheses indicates the year of last reapproval. A superscript epsilon (ϵ) indicates an editorial change since the last revision or reapproval.

^ε¹ NOTE—Editorial changes were made throughout in April 2011.

INTRODUCTION

This guide provides methods to measure the sound isolation of a room from outdoor sound, and to evaluate the sound transmission or apparent sound transmission through a particular facade of the room or an element of that facade such as a window or door. Measurements from outdoors to indoors differ from measurements between two rooms. The outdoor sound field is not diffuse and the transmission of that sound through the structure is a function of the outdoor sound angle of incidence. The outdoor-indoor transmission loss values obtained with this guide are not expected to be the same as that obtained in laboratory or other tests between two rooms using diffuse incident sound. At this time, there are insufficient data available to specify a single, standard measurement procedure suitable for all field situations. For this reason, this guide provides alternative test procedures for the measurements of facade field level reduction and transmission loss.

This guide is part of a set of standards for evaluating the sound isolation of rooms and the sound insulating properties of building elements. Others in this set cover the airborne sound transmission loss of an isolated partition element in a controlled laboratory environment (Test Method E90), the laboratory measurement of impact sound transmission through floors (Test Method E492), the measurement of airborne sound transmission in buildings (Test Method E336), the measurement of impact sound transmission in buildings (Test Method E1007), and the measurement of sound transmission through a common plenum between two rooms (Test Method E1414).

1. Scope

1.1 This guide may be used to determine the outdoor-indoor noise reduction (OINR), which is the difference in sound pressure level between the free-field level outdoors in the absence of the structure and the resulting sound pressure level in a room. Either a loudspeaker or existing traffic noise or aircraft noise can be used as the source. The outdoor sound field geometry must be described and calculations must account for the way the outdoor level is measured. These results are used with Classification E1332 to calculate the single number rating outdoor-indoor noise isolation class, OINIC. Both OINR and OINIC can vary with outdoor sound incidence angle.

1.2 Under controlled circumstances where a single facade is exposed to the outdoor sound, or a facade element such as a

door or window has much lower transmission loss than the rest of the facade, an outdoor-indoor transmission loss, OITL(θ), or apparent outdoor-indoor transmission loss, AOITL(θ), may be measured using a loudspeaker source. These results are a function of the angle of incidence of the sound field. By measuring with sound incident at many angles, an approximation to the diffuse field transmission loss as measured between two rooms can be obtained. The results may be used to predict interior sound levels in installations similar to that tested when exposed to an outdoor sound field similar to that used during the measurement. The single number ratings of apparent outdoor-indoor transmission class, AOITC(θ), using AOITL(θ) and field outdoor-indoor transmission class, FOITC(θ), using OITL(θ) may be calculated using Classification E1332. These ratings also may be calculated with the data obtained from receiving room sound pressure measurements performed at several incidence angles as discussed in 8.6.

1.3 To cope with the variety of outdoor incident sound field geometries that are encountered in the field, six testing techniques are presented. These techniques and their general applicability are summarized in Table 1 and Figs. 1-6. The

¹ This guide is under the jurisdiction of ASTM Committee E33 on Building and Environmental Acoustics and is the direct responsibility of Subcommittee E33.03 on Sound Transmission.

Current edition approved Sept. 1, 2010. Published December 2010. Originally approved in 1984. Last previous edition approved in 2004 as E966–04. DOI: 10.1520/E0966-10E01.

TABLE 1 Application Guide to Measurement of Outdoor-Indoor Level Reduction ONIR

Outdoor Signal Source Loudspeaker Required for OITL or AOTL	Outdoor Microphone Position	Measurement Section, Figure, Calculation Equation	Applications Remarks
Calibrated loudspeaker	Incident sound pressure inferred from separate calibration of source	8.3.1, Fig. 1; Eq 3	Use when outdoor measurement at or near specimen is not possible.
Loudspeaker	Several locations averaged about 1.2 m to 2.4 m from the facade element	8.3.2, Fig. 2; Eq 4	Use when calibrated source or flush measurement is not possible.
Loudspeaker	Several locations less than 17 mm from specimen	8.3.3, Fig. 3; Eq 5	Use when the loudspeaker cannot be calibrated.
Traffic, aircraft, or similar line source	Simultaneous measurement remote from the specimen	9.3.1, Fig. 4; Eq 7	Use when it is possible to measure source in free field at same distance as specimen.
Traffic, aircraft, or similar line source	Simultaneous measurement 2 m from the specimen surface	9.3.2, Fig. 5; Eq 9	Use when remote measurement or flush measurement is not possible.
Traffic, aircraft, or similar line source	Simultaneous measurement with entire microphone diaphragm within 17mm of the specimen	9.3.3, Fig. 6; Eq 10	Use when remote measurement is not possible.

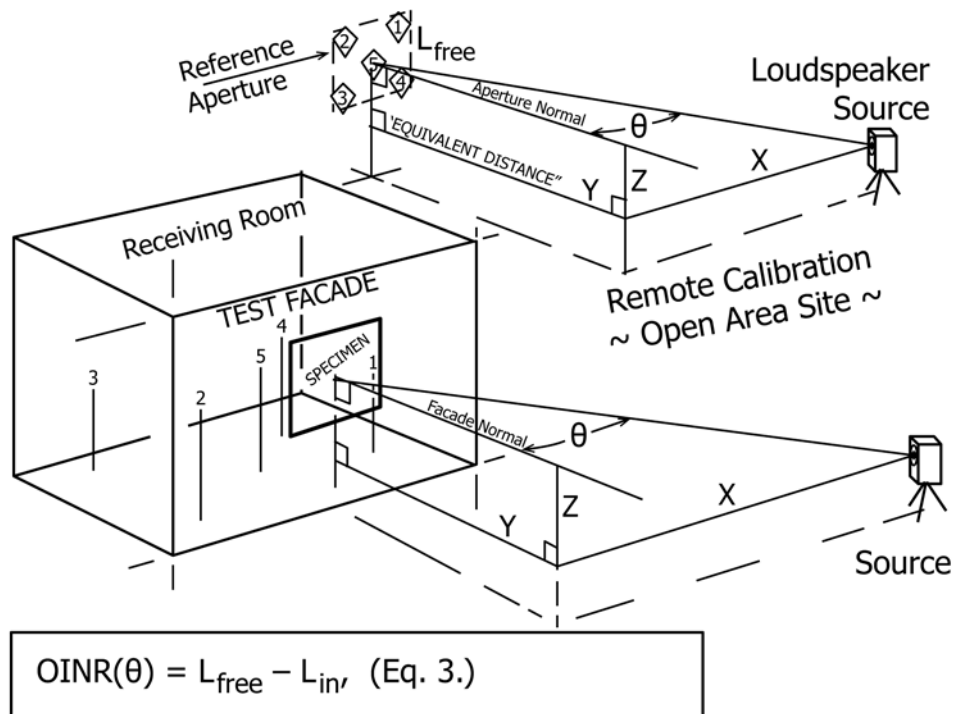

FIG. 1 Geometry—Calibrated Source Method

room, façade, or façade element declared to be under test is referred to as the specimen.

1.4 The values stated in SI units are to be regarded as standard. No other units of measurement are included in this standard.

1.5 *This standard does not purport to address the safety concerns, if any, associated with its use. It is the responsibility of the user of this standard to establish appropriate safety and health practices and determine the applicability of regulatory limitations prior to use.*

1.6 The text of this standard references notes and footnotes which provide explanatory material. These notes and footnotes (excluding those in tables and figures) shall not be considered as requirements of the standard.

2. Referenced Documents

2.1 *ASTM Standards:*²

[C634 Terminology Relating to Building and Environmental Acoustics](#)

[E90 Test Method for Laboratory Measurement of Airborne Sound Transmission Loss of Building Partitions and Elements](#)

[E336 Test Method for Measurement of Airborne Sound Attenuation between Rooms in Buildings](#)

² For referenced ASTM standards, visit the ASTM website, www.astm.org, or contact ASTM Customer Service at service@astm.org. For *Annual Book of ASTM Standards* volume information, refer to the standard's Document Summary page on the ASTM website.

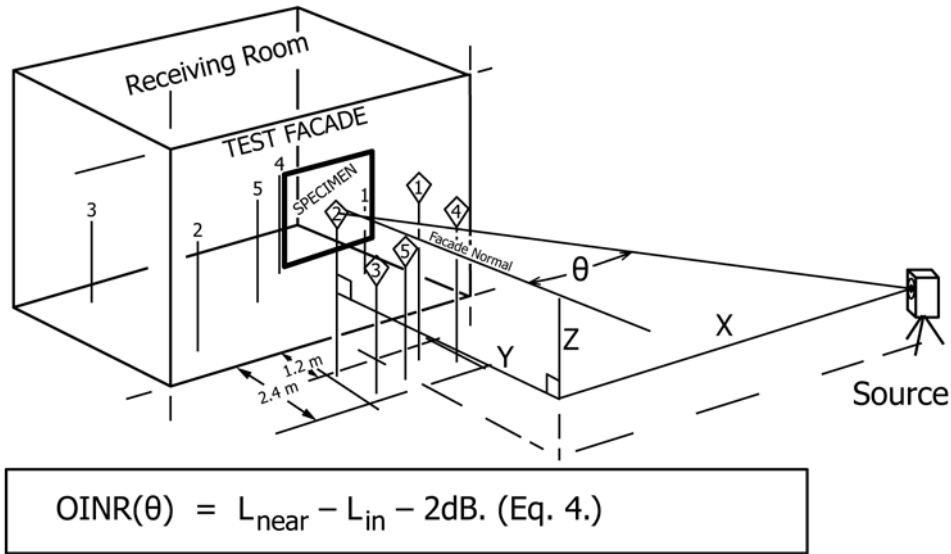

FIG. 2 Geometry—Nearby Average Method

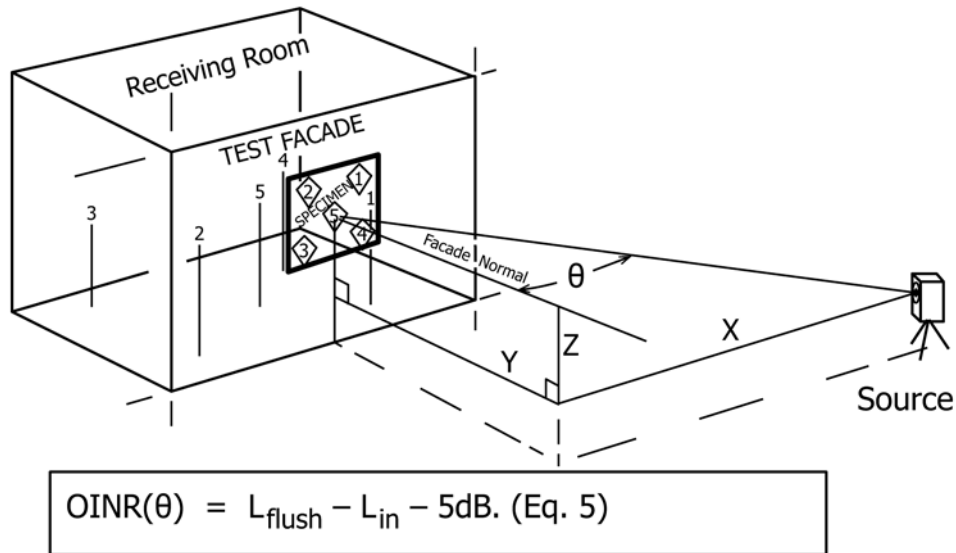

FIG. 3 Geometry—Flush Method

- E492 Test Method for Laboratory Measurement of Impact Sound Transmission Through Floor-Ceiling Assemblies Using the Tapping Machine
- E1007 Test Method for Field Measurement of Tapping Machine Impact Sound Transmission Through Floor-Ceiling Assemblies and Associated Support Structures
- E1332 Classification for Rating Outdoor-Indoor Sound Attenuation
- E1414 Test Method for Airborne Sound Attenuation Between Rooms Sharing a Common Ceiling Plenum
- E2235 Test Method for Determination of Decay Rates for Use in Sound Insulation Test Methods

2.2 ANSI Standards:³

- S1.11 Specification for Octave-Band and Fractional-Octave Analog and Digital Filter Sets
- S1.40 Specifications and Verification Procedures for Sound Calibrators
- S1.43 Specifications for Integrating -Averaging Sound Level Meters

³ Available from American National Standards Institute (ANSI), 25 W. 43rd St., 4th Floor, New York, NY 10036, <http://www.ansi.org>.

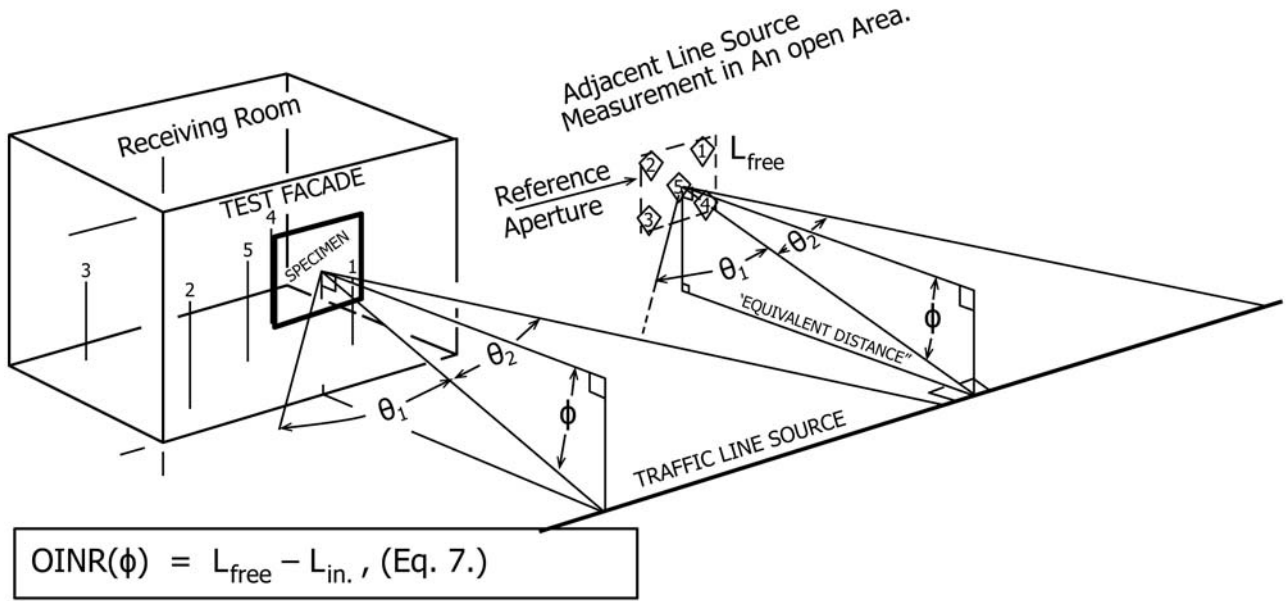

FIG. 4 Geometry—Equivalent Distance Method

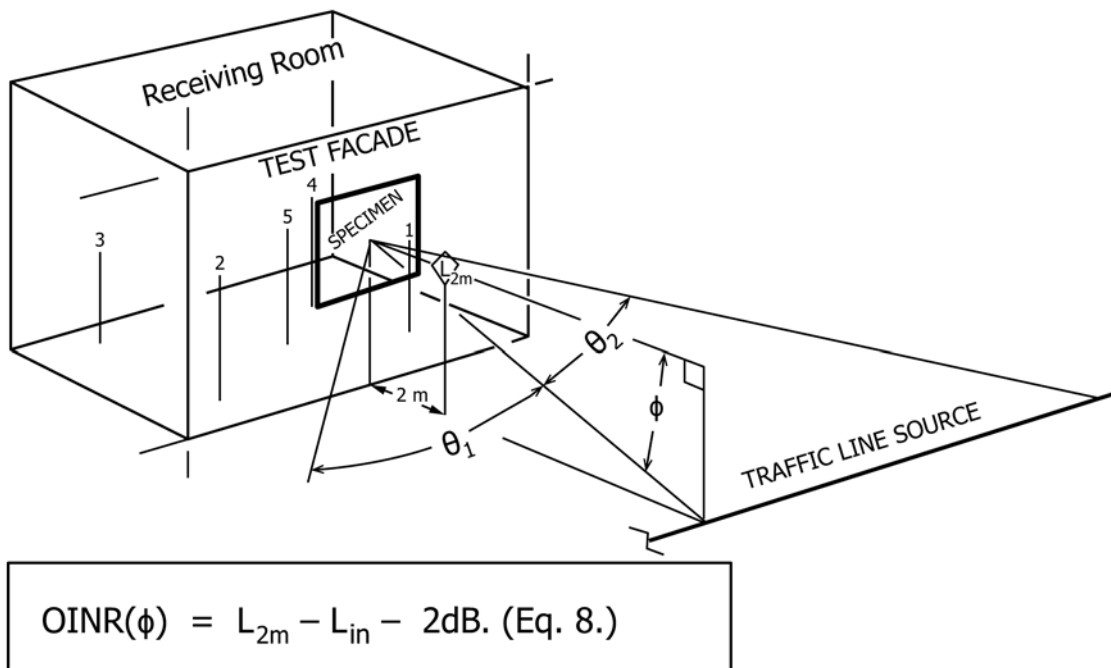

FIG. 5 Geometry—2 m (79 in.) Position Method

2.3 IEC Standards:³

IEC 61672 Electroacoustics - Sound Level Meters

IEC 60942 Electroacoustics - Sound Calibrators

3. Terminology

3.1 Definitions—for acoustical terms used in this guide, see Terminology C634.

3.2 Definitions of Terms Specific to This Standard:

3.2.1 *apparent outdoor-indoor transmission class, apparent AOITL*(θ), *n*—of a building façade or façade element at a specified angle θ or range of angles, a single-number rating calculated in accordance with Classification E1332 using measured values of apparent outdoor-indoor transmission loss.

3.2.2 *apparent outdoor-indoor transmission loss, AOITL*(θ), (*dB*), *n*—of a building facade or facade element in a specified frequency band, for a source at a specified angle θ or range of

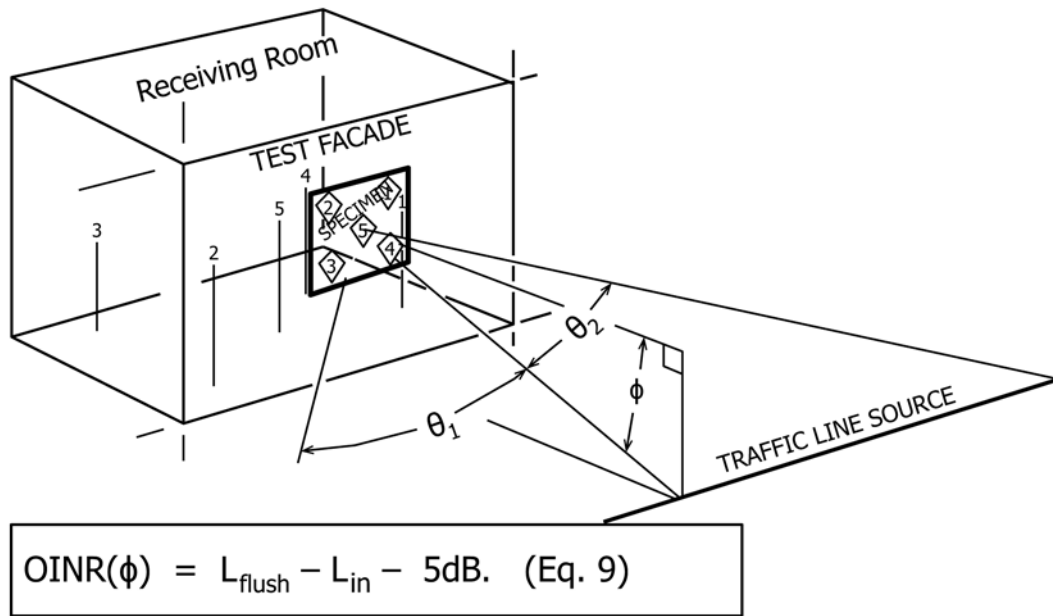

FIG. 6 Geometry and Formulas—Line Source Flush Method

angles as measured from the normal to the center of the specimen surface, the value of outdoor-indoor transmission loss obtained on a test facade element as installed, without flanking tests to identify or eliminate extraneous transmission paths.

3.2.2.1 *Discussion*—This definition attributes all the power transmitted into the receiving room, by direct and flanking paths, to the area of the test specimen. If flanking transmission is significant, the AOITL will be less than the actual OITL for the specimen.

3.2.3 *field outdoor-indoor transmission class, FOITC*(θ), n —of a building façade or façade element at a specified angle θ or range of angles, the single number rating obtained by Classification E1332 with OITL values.

3.2.4 *outdoor-indoor noise isolation class, OINIC*, n —of an enclosed space, a single-number rating calculated in accordance with Classification E1332 using values of outdoor-indoor noise reduction.

3.2.4.1 *Discussion*—OINIC is an A-weighted level difference based on a specific spectrum defined in Classification E1332.

3.2.5 *outdoor-indoor noise reduction, OINR*(θ), n —which may or may not be a function of angle θ or a range of angles, in a specified frequency band the difference between the space-time average sound pressure level in a room of a building and the time-averaged exterior sound pressure level which would be present at the facade of the room were the building and its facade not present.

3.2.5.1 *Discussion*—The outdoor-indoor noise reduction has been known previously in this guide as the outdoor-indoor level reduction, OILR. For measured data, the OINR (θ) may be used to indicate results at a specific angle (θ) as discussed in 8.5. ONIR may be used to indicate the weighted average of measurements over a range of angles as discussed in 8.6 or a

measurement result due to exposure to a line source as discussed in Section 9.

3.2.6 *outdoor-indoor transmission loss, OITL*(θ), (dB), n —of a building façade or façade element in a specified frequency band, for a source at a specified angle θ or range of angles as measured from the normal to the center of the specimen surface, ten times the common logarithm of the ratio of airborne sound power incident on the specimen to the sound power transmitted through it and radiated to the room interior.

3.2.6.1 *Discussion*—The unqualified term OITL(θ) signifies that flanking tests have been performed according to Annex A1 to verify that there was no significant flanking or leakage transmission. In the absence of such tests, the test result may be termed the AOITL(θ) (see 3.2.2).

3.2.7 *sound exposure level*—*SEL in decibels where the “*” denotes the frequency weighting such as CSEL for C-weighting (understood to be A if absent).

3.2.8 *one-third octave-band sound exposure—level one-third octave-band SEL*(f), (dB), n —ten times the logarithm to the base ten of the ratio of a given time integral of squared instantaneous sound pressure in a specific one-third octave-band of center frequency f , over a stated time interval or event, to the product of the squared reference sound pressure of 20 micropascals and reference duration of one second.

3.2.9 *traffic noise*—noise emitted by moving transportation vehicles, such as cars, trucks, locomotives, or aircraft moving along an extended line path.

4. Summary of Guide

4.1 This guide provides procedures to measure the reduction in sound level from the outdoors to an enclosed room, the outdoor-indoor level reduction, OINR, with a variety of sources and methods. With further measurements under restricted conditions using a loudspeaker source, a basic property

of a facade or facade element, the outdoor-indoor transmission loss, OITL(θ), may be determined. This requires that the conditions of Annex A1 be met to demonstrate that flanking of sound around the test specimen is not significant. If it is not possible to meet the conditions of Annex A1, the AOITL(θ) is reported. These results measured with a loudspeaker will vary with the angle of the source θ as measured from the normal to the surface as shown on Fig. 7. The OINR(θ), the AOITL(θ), and the OITL(θ) may be reported for a variety of angles. The result using traffic noise, OINR(line, Φ), can depend on the incidence angle Φ , from the normal to the point at closest approach. See Fig. 8),

4.2 Sources of Test Signal:

4.2.1 Loudspeaker Source—The outdoor sound pressure level produced by a loudspeaker source is either inferred from a previous calibration of the level emitted by that loudspeaker at a specific distance (Fig. 1 and 8.3.1), or it is measured near the façade (Fig. 2 and 8.3.2), or it is measured flush to the facade (Fig. 3 and 8.3.3). When the outdoor sound level is measured near the facade, measurements shall be averaged over several locations near the test specimen to minimize effects of incident and reflected sound wave interference. The test sound incidence angle, θ , is determined and reported.

4.2.2 Traffic Source—In the traffic noise method used for OINR only, movement of noise sources along a line such as a highway or flight path combined with time averaging will minimize sound wave interference effects. See Figs. 4-6. To

account for source fluctuations using the traffic noise method, the incident sound level is measured synchronously with the indoor sound level.

4.3 To avoid extraneous noise and propagation anomalies, the measurements shall be made without precipitation and when the wind speed is less than 5 m/s.

4.4 Sound measurements made to assess the sound attenuation of an exterior partition should be conducted in a series of one-third octave-band frequencies from at least 80 to 4000 Hz, preferably to 5000 Hz. Such data can be used to compute the expected performance of the specimen exposed to a specific spectrum of sound, such as is done using Classification E1332.

5. Significance and Use

5.1 The best uses of this guide are to measure the OINR and the AOITL(θ) or OITL(θ) at specific angles of incidence. By measuring the AOITL(θ) or OITL(θ) at several loudspeaker sound incidence angles, by energy-averaging the receiving room sound levels before computing results, an approximation of the diffuse field results measured with Test Methods E90 and E336 may be obtained.

5.2 The traffic noise method is to be used only for OINR measurements and is most suitable for situations where the OINR of a specimen at a specific location is exposed to an existing traffic noise source.

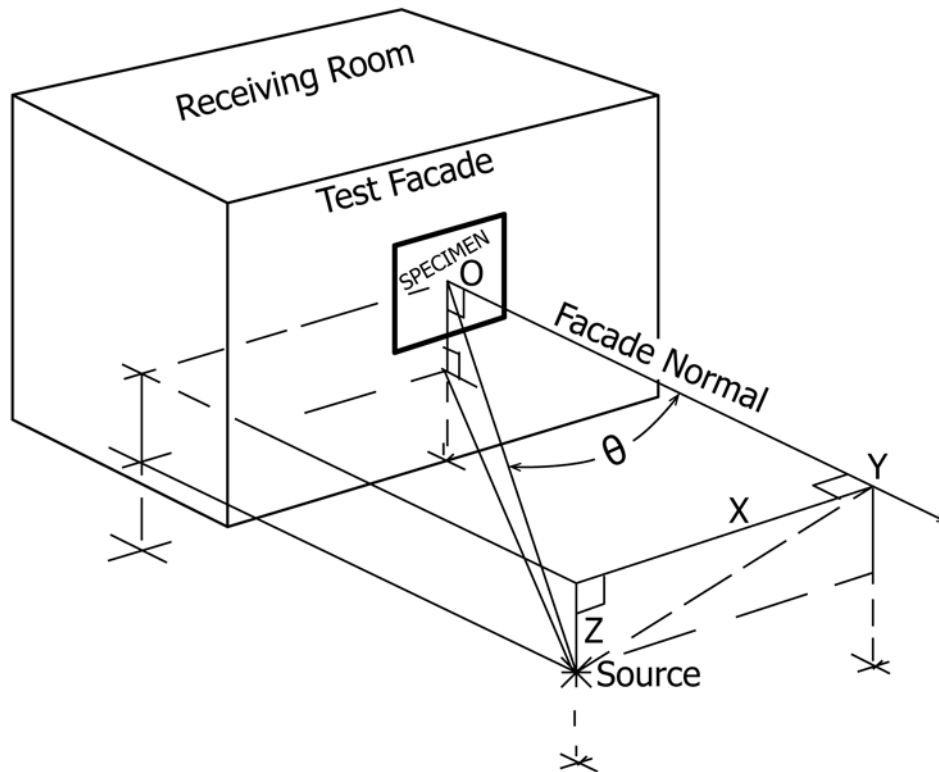

θ = angle of incidence.

FIG. 7 Source Location (*) and θ Definition

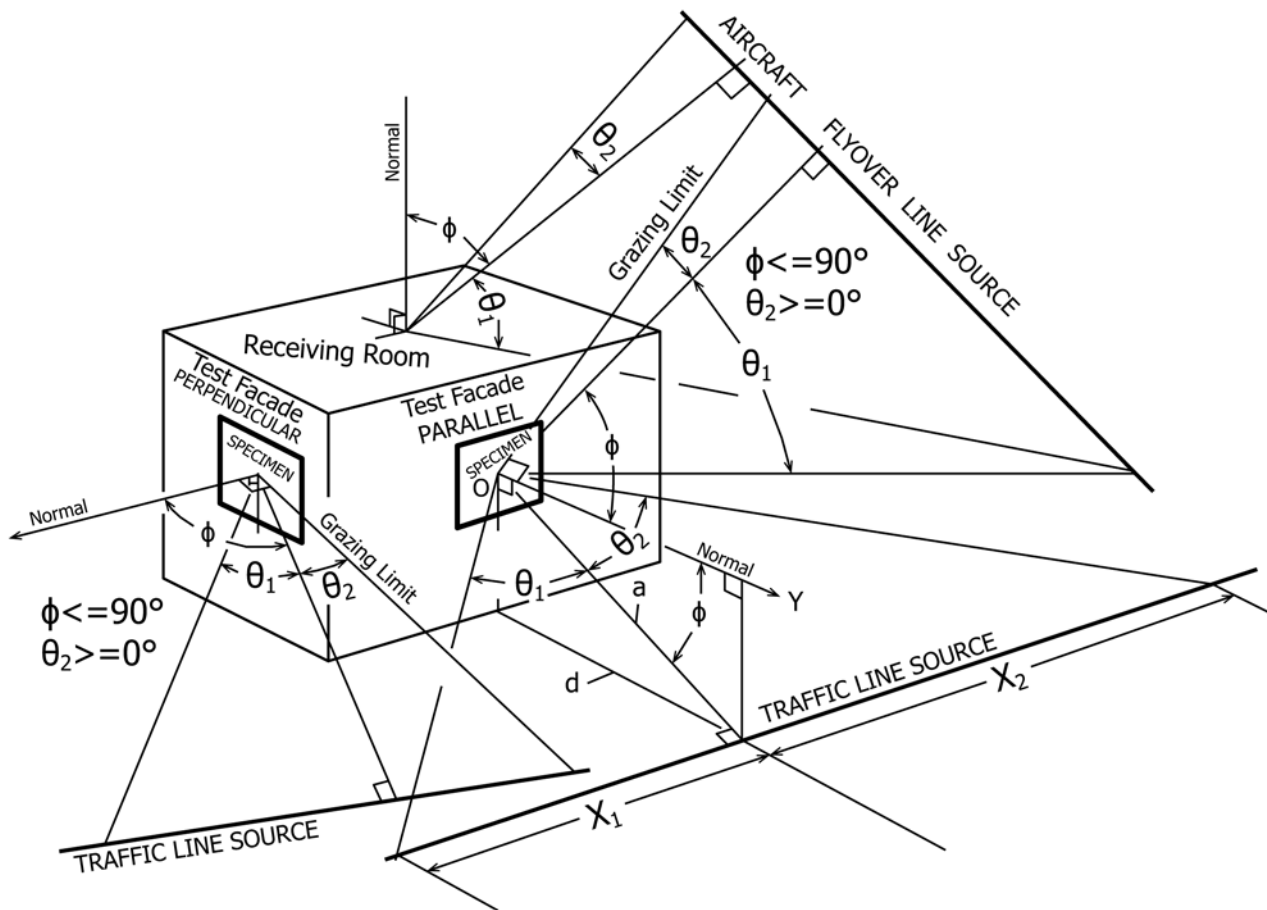

FIG. 8 Location of Traffic Line Source and Orientation of Incidence Angles with Respect to Traffic Flow and Facade Normal

5.3 The OINR, AOITL(θ), and OITL(θ) produced by the methods described will not correspond to the transmission loss and noise reduction measured by Test Methods E90 and E336 because of the different incident sound fields that exist in the outdoors (1)⁴. All of these results are a function of the angle of incidence of the sound for two reasons.

5.3.1 The transmission loss is strongly influenced by the coincidence effect where the frequency and projected wavelength of sound incident at angle, θ , coincides with the wavelength of a bending wave of the same frequency in the panel (2, 3, 4, 5). This frequency and the angle of least transmission loss (greatest transparency) both depend on specimen panel stiffness, damping and area mass. In diffuse-field testing as in the laboratory, the effect is a weakness at the diffuse field average coincidence frequency that is dependent on material and thickness, often seen around the frequency of 2 500 Hz for drywall and glass specimens. For free field sound coming from one direction only, the coincidence frequency varies with incidence angle and will differ from the diffuse-field value (5). Near or at grazing ($\theta \leq 90^\circ$) it will be much lower in frequency than the diffuse field (E90 and E336) value, and will increase with reducing θ to be considerably above the diffuse-field frequency when θ is 30° or less. Wood panels (that

⁴ The boldface numbers in parentheses refer to a list of references at the end of this standard.

is, doors) and masonry walls exhibit lower coincidence frequencies while sheet steel exhibits higher coincidence frequencies.

5.3.2 The OINR is influenced by the angle of incidence of free field sound coming from a specific angle as compared to a diffuse field. This is because the intensity of free field sound incident across the specimen surface S is reduced by $\cos(\theta)$ when the sound is not incident normal to the surface. Additionally, when the sound of level L arrives as a free-field from one direction only, and that is normal to the surface, the resulting sound intensity in this direction is 4 times that due to diffuse-field sound of the same level, L . These factors are reflected by the $\cos(\theta)$ and 6 dB terms in Eq 6.

5.3.3 The methods in this guide should not be used as a substitute for laboratory testing in accordance with Test Method E90.

5.4 Of the three methods cited for measuring the outdoor sound field from a loudspeaker, the calibrated loudspeaker and flush methods are most repeatable. The near method is used only when neither the calibrated speaker nor the flush method are feasible.

5.5 Flanking transmission or unusual field conditions could render the determination of OITL(θ) difficult or meaningless. Where the auxiliary tests described in Annex A1 cannot be satisfied, only the OINR and the AOITL(θ) are valid.

5.6 When a room has multiple surfaces exposed to outdoor sound, testing with just one surface exposed to test sound will result in a greater OINR than when all surfaces are exposed to test sound. The difference is negligible when the OITC of the unexposed surface is at least 10 greater than the OITC of the exposed surface.

6. Conditions Required to Measure AOITL(θ) or OITL(θ) of a Façade or Facade Element Specimen

6.1 The specimen under test will often be a complete façade wall enclosing one room (the receiving room). The room selected for test must be surrounded with equal or better construction, with no obvious leakage paths such as open windows in adjacent spaces. Rooms at the top floor of a building or at a corner might be unsuitable for wall, window, and door testing because of flanking transmission through the roof. A room at the corner of a building may be undesirable for evaluating a small specimen since sound penetrating the adjoining exterior wall may be difficult to assess.

6.2 If a relatively massive facade contains a low-mass element such as a window or door, the latter could be considered the specimen under test on the assumption that it transmits a greater amount of incident sound. The specimen area, S in Eq 6, shall include its perimeter joints and framing.

6.3 If the OITL is to be measured, flanking measurement according to Annex A1 must be made by blocking the specimen under test as defined in 6.2. This test determines the degree to which sound transmits through the remainder of the facade. The OITL(θ) may be computed with the result of Eq A1.1, and so stated in the report according to 12.1.2.

7. Properties of the Receiving Room Required to Determine OITL(θ) or AOITL(θ)

7.1 The sound transmitted through the specimen is measured in an adjacent receiving room. This room must form an enclosed space. See Figs. 1-6. The ratio of the incident power to the power transmitted and radiated into the room is calculated using the space- and time-averaged room sound pressure level and room sound absorption.

7.2 *Receiving Room Shape and Volume*—The receiving room must form an enclosed space. For determining the OITL(θ) or AOITL(θ), the room length, width, and height should be all different with the largest dimension no greater than twice the shortest. The smallest room dimension must be at least 2.3 m. Except for windows and doors, the specimen dimensions should be at least 2.3 by 2.4 m.

7.2.1 The volume of the receiving room determines to a large extent the lowest frequency at which the sound fields are adequately uniform. The larger the room, the lower the limiting frequency. In all cases, the room volume must be reported. For measurement of AOITL(θ) at frequencies of 125 Hz and higher and the reporting of AOITC(θ), the receiving room volume must be at least 25 m³. For measurement of OITL(θ) at frequencies of 125 Hz and higher and the reporting of FOITC(θ), the room volume must be at least 40 m³.

7.3 *Diffusion*—For determining an accurate spatial sound pressure level, it is preferred that the receiving room contains diffusing objects such as hard furniture.

7.4 *Receiving Room Sound Absorption Measurement for Determining OITL(θ) and AOITL(θ):*

7.4.1 It is preferred that the receiving room should have hard wall, ceiling, and floor surfaces. The receiving room sound absorption shall not exceed:

$$A_2 = V^{2/3} \text{ for AOITL}(\theta) \text{ when the room volume is } 150 \text{ m}^3 \text{ or more, (1)}$$

$$A_2 = V^{2/3} \text{ for OITL}(\theta) \text{ in any size room (2)}$$

where:

V = room volume, m³ (ft³), and

A_2 = absorption, m².

7.4.2 *Measurement of the Receiving Room Sound Absorption, A_2 :*

7.4.2.1 When room sound absorption or decay rate must be measured in the receiving room to determine the AOITL(θ) or OITL(θ), they shall be determined in accordance with Test Method E2235.

8. OINR (θ), AOITL (θ), and OITL (θ) Measurement with a Fixed (Loudspeaker) Source

8.1 *Measurements:*

8.1.1 Specific measurement procedures are provided for each measurement method in 8.3 and 8.4.

8.1.2 *Site Background Noise*—Where possible turn off any extraneous interfering noise sources either indoors or outdoors. Measure the background sound both indoors and outdoors in the same way the test noise levels are measured with the source operating. Make adjustments for this background noise as required by Section 10. It may be necessary to conduct measurements during periods of low indoor and outdoor ambient noise to meet these requirements.

8.1.3 One-third octave-band filtering should be used in the measuring system to reduce the effects of background sound on measurements.

8.1.4 Bands of random noise may exhibit minor fluctuations in level with time. Measurements should be averaged over at least 15 s below 250 Hz, and 5 s at 250 Hz and higher.

8.2 *Generation of Outdoor Sound Field:*

8.2.1 *Loudspeaker Sound Emission Characteristics*—A single loudspeaker enclosure is preferred. Its directional characteristic should be such that at 2 000 Hz the free-field radiated sound pressure up to an angle of 45° off-axis shall not be more than 6 dB different from the on-axis sound pressure. It must supply sufficient output in all measurement bands to achieve sound levels at least 5 dB and preferably 10 dB over the background level in the receiving room over the range from 80 to 4 000 Hz. It may be necessary to add a high frequency loudspeaker in or on the enclosure to achieve sound that is reasonably distributed over the specimen area and to have the transmitted sound be above the background noise in the receiving room.

8.2.2 *Test Signal*—The electrical signal to the loudspeaker shall consist of random noise over the test frequency range. It may be necessary to filter the spectrum of the noise source to concentrate the available speaker sound power capability in a few bands to increase the receiver room sound pressure level. In such cases, the bandwidth of the filter applied to the source

signal shall extend at least one-third octave-band above and below the frequency band(s) measured in the receiving room.

8.2.3 Geometry of the Angle of Incidence—As shown in Fig. 7, the loudspeaker shall be located to create sound arriving at the specimen at a specified angle of incidence, θ , which is the angle between a perpendicular line OY at the midpoint of the specimen and the line from that midpoint to the source. In this guide, this angle can lie in any plane. See also Figs. 1-3.

8.2.3.1 When the test objective is to evaluate the performance of a specimen for a particular source location, the test should duplicate the condition of concern as closely as possible.

8.2.3.2 When the test objective is to minimize the number of source locations, an incident angle, θ , of 45 is preferred. If these results are to be compared to those obtained in a diffuse sound field, measurements should be made at angles of 15, 30, 45, 60 and 75 and averaged according to 8.6.1. The source positions should preferably be in the vertical plane through the center of the specimen and perpendicular to the specimen.

8.2.3.3 If the facade has major irregularities such as balconies, additional measurement directions may be needed to provide adequate representation of the facade performance. The preferred set of additional source positions are in the horizontal plane through the center of the specimen. If measurements are made at several angles of incidence, the individual values of OITL(θ) should be reported. The OITL(θ) is computed with Eq 6.

8.2.4 Distance of Source from Test Specimen—The source shall be far enough from the specimen so that the ratio of the distances from the source in the farthest and nearest parts of the test surface is no more than two. The loudspeaker axis shall be directed toward the center of the specimen, favoring the more remote edge only as needed to make the sound pressure variation across the specimen as small as possible, preferably within 3 dB.

8.2.5 Rooms with multiple surfaces—If a room has multiple exterior surfaces such as two perpendicular walls or walls and roof, and a loudspeaker source is used, each surface must be tested and reported separately.

8.2.5.1 If it is desired to establish the OINR of the room for a source at a specific fixed location, the loudspeaker can be placed in that location or in that direction.

8.2.5.2 If it is desired to establish the OINR of each surface including flanking, such as to establish the AOITL of each surface, test the surface following normal requirements.

8.2.5.3 If a room surface other than the one primarily exposed in the test is much weaker, sound flanking around through that weaker surface may be the primary path of sound into the room. This is still a valid test of the OINR of the room for this defined exposure.

8.2.5.4 If the room has multiple surfaces exposed to moving or distributed sources, and it is desired to use data from loudspeaker tests to predict interior levels or to determine the OITL, then the OINR of each individual surface must be established separately. This requires minimizing the influence of sound passing through surfaces not under test (see A1.2.2) by covering weak areas such as doors, windows or

penetrations, or by using outdoor sound barriers parallel to and extended from the surface under test.

8.2.5.5 If multiple room surfaces are exposed simultaneously in actual use, the sound reaching the room interior will be sum of the total sound through each of the surfaces, and the sound level inside will be higher than predicted based on the OINR of a single side.

8.2.5.6 If the expected overall interior sound level due to simultaneous exposure of several surfaces is desired, determine the OINR for each surface. Determine the exposure SPL for each surface. An estimate of the sum of the sound through all the affected surfaces is the sum of the resulting sound levels.

8.2.5.7 This guide does not provide a way to use the tests of individual surfaces to provide an OINR of the room due to exposure on multiple surfaces.

8.3 Determination of Outdoor Sound Pressure Level:

8.3.1 Calibrated Loudspeaker Source Method (Fig. 1)—The sound pressure incident on the specimen is inferred from a prior calibration of the source of constant test sound such as a loudspeaker. In addition to the requirements of 8.2.1 and 8.2.2, this source shall be calibrated in a free-field (echo-free) environment, and at the same distance that the source is to be from the specimen. Measurements are made of L at all test frequencies at a distance from the source and at an angle from the source (loudspeaker) axis corresponding to the loudspeaker location relative to the specimen (Fig. 1 inset). Each level measurement must be averaged over a sufficient time period (see 8.1.3). The level L at each frequency is assumed to be the sound pressure level incident on the specimen without the specimen and without reflections from surrounding building components. Average the sound pressure level found at five random positions within the reference aperture that corresponds to the expected location of the test specimen. See Fig. 1. In addition, measure and record a near-field calibration value at a fixed short distance on-axis, that is, at 0.5m, to provide a value that shall be verified at the time of specimen test.

8.3.1.1 The calibration site ground must be similar to that at the test site. The objective is that the sound pressure level imposed on the specimen, were the specimen not there, shall be the same as found during calibration. The effect of nearby object reflections at higher frequencies is determined by blocking or deflecting all evident reflection paths with a screen or by applying a sound absorber to those surfaces. For purposes of this guide, the calibration site meets the free-field requirement when the L calibration level does not change by more than 1 dB when the screen(s) and absorber(s) are removed.

NOTE 1—When outdoor measurements made proximate to another building facade are influenced by reflections from that other building, it should be so stated in the test report. This fact is especially important when the test noise source is a calibrated loudspeaker or a traffic source at an equivalent distance.

8.3.2 Outdoor Measurement Near the Specimen (Fig. 2)—Measure the outdoor sound pressure level near the specimen. To minimize wave interference effects, average five or more measurements at random distances from the specimen, at random positions across the specimen, and at varying heights across the specimen. The random distances should be in the range of more than 1.2 m and less than 2.5 m from the

specimen. The random positions and random heights should be within the left, right, upper, and lower limits of the specimen. If there are projections from the primary surface, measure 1.2 to 2.5 m from those for sample locations near them.

8.3.3 Flush Outdoor Measurement Position (Fig. 3)—This measurement method is feasible when the specimen is smooth and hard. Measure the sound pressure with a small condenser microphone 13 mm in diameter mounted very close to the specimen surface at the midpoint and at other positions on the surface of the specimen, but not so close that it is likely to touch the specimen surface or impede the airflow through the microphone grille (see also 11.1.3). It is suggested that up to five measurements about the surface of the specimen be made and averaged.

NOTE 2—The sound absorption of the specimen surface must be very low (6). If the microphone diaphragm is entirely within 17 mm of the surface, it provides acceptable flush measurements for frequencies up to 5000 Hz (7).

8.4 Indoor Sound Pressure Level Determination—Measure the average sound pressure level in the room.

8.4.1 Fixed microphone positions or a single moving microphone manually swept or moving continuously along a circular path may be used while satisfying the following conditions:

8.4.1.1 No microphone position shall be closer than 1 m to the inside surface of the exterior wall or to any other boundary or extended surface, unless the room is too small to allow adequate microphone positions within this restriction in which case the microphones may be within 0.5 m of surfaces other than the specimen

8.4.1.2 For a fixed microphone, a minimum of three microphone positions is required, but up to six are recommended.

8.4.1.3 The minimum separation of fixed microphone positions should be 1 m but may be less in small rooms if necessary to get adequate number of microphone positions.

8.4.1.4 For a moving microphone use an integrating averaging sound level meter meeting the requirements of ANSI S1.43 or IEC 61672.

8.4.1.5 The minimum averaging time for a moving microphone shall be 30 s.

8.4.2 If and only if only OINR is being reported, and if the room volume is 150 m³ or more, all measurements shall be made 1 to 2 m from the specimen and at least 1 m from other surfaces intersecting the specimen. For a moving microphone, this 1 to 2 m area should be scanned, but not more than 2 m above the floor for the case of vertical facades. For fixed microphones, the minimum number shall be determined by dividing the largest dimension of the specimen in meters by 3 and rounding up to the next integer. These positions are not permitted for OITL and AOITL.

8.5 Determination of Outdoor-Indoor Noise Reduction (OINR):

8.5.1 Calibrated Source Method—If the incident outdoor level L has been established by prior calibration as in 8.3.1, the value of OINR is calculated using:

$$OINR(\theta) = L_{free} - L_{in}(\theta) \quad (3)$$

where:

- L_{free} = Calibrated level, L , and
- $L_{in}(\theta)$ = Average sound pressure level in the room enclosed by the specimen, dB, caused by exterior sound incident at angle θ , and
- θ = Angle of incidence, that is, the angle between the source position and the perpendicular to the test element midpoint, degrees. (See Fig. 1, Fig. 2, and Fig. 3.)

8.5.2 Nearby Microphone Method—The presence of the façade approximately doubles the sound pressure near the façade (+3 dB), but in practice, this increase is found less; a 2 dB representation is used here. The average outdoor sound pressure level is measured near the specimen as described in 8.3.2. The OINR for that angle is calculated using:

$$OINR(\theta) = L_{near} - L_{in}(\theta) - 2 \text{ dB} \quad (4)$$

8.5.3 Flush Microphone Method—The presence of the façade approximately quadruples the sound pressure (+6 dB) on the specimen. But in practice, this increase is found to be about 5 dB (8). See also X1.1. When the outdoor sound pressure level has been measured very close to the surface as described in 8.3.3, the OINR(θ) value for that angle is calculated using:

$$OINR(\theta) = L_{flush} - L_{in}(\theta) - 5 \text{ dB} \quad (5)$$

NOTE 3—The 2 dB and 5 dB factors in Eq 4, Eq 5, Eq 9, and Eq 10 differ by one dB from the theoretically expected differences shown in earlier versions of this guide. This difference is based on experimental observations documented in reference (8).

8.6 Calculation of AOITL(θ) and OITL(θ)—Calculate AOITL(θ) or OITL(θ) using :

$$OITL(\theta) = OINR(\theta) + 10 \log(S^* \cos(\theta)/A_2) + 6 \text{ dB} \quad (6)$$

where:

- S = Area of the specimen
- A_2 = room sound absorption determined in, 7.4, m².

8.6.1 This AOITL(θ) or OITL(θ) measured at angle θ is valid only for that angle. These results cannot be predicted for other angles. To compare this OITL(θ) results with the results for equal specimens found with Test Method E90, the sound energy transmitted at all incidence angles must be averaged. An approximation to this average is found by measuring the room sound pressure level for several loudspeaker sound incidence angles. These angles may be chosen to represent equal areas of a hemisphere, so that the resultant pressures need only be pressure squared averaged. For three measurement angles, θ , these angles are 34°, 60°, and 80°. If a uniform angular increment is more convenient, a weighting factor must be applied to the measured pressure squared values at each angle. For instance, for incidence angles of 15°, 30°, 45°, 60°, and 75°, the factors that weight each pressure squared measurement according to the hemispherical solid angle of incidence that it represents are respectively 0.08, 0.15, 0.22, 0.26, and 0.29. If measurements are made only at 30° and 60°, the corresponding factors are respectively 0.37 and 0.63. This pressure squared average, expressed in decibels is $L_{in}(\theta)$, used in Eq 6 to compute OITL(θ) or AOITL(θ).

9. Measurement of OINR with Traffic Noise (Fig. 8, or any Extended Line of Similar Sources)

9.1 Traffic noise may be used as the source of noise for the measurement of OINR(line,Φ) only. Often these measurements are made to evaluate the performance of a specific structure at a specific location (9). Otherwise, the requirements of 9.2.1 must be met. OITL(θ) shall only be measured using a controlled point source, as described in Section 8.

9.2 *Line Source Measurement Site*(Fig. 8)—When measurements are intended to indicate the typical performance of a specimen that may occur at various locations, an acceptable traffic noise site is one for which the specimen surface is parallel to a straight and level traffic route that is long enough to include angles of incidence up to at least 70° in each direction, (θ1+θ2>140°). The angle of incidence at the point of traffic closest approach, Φ, must be no greater than 30° at the vehicle location nearest to the specimen. See Fig. 4, Fig. 5, or Fig. 6. If these restrictions are not met, though the result is valid for the angle Φ tested, this OINR(line,Φ) shall not be used to typify the general noise isolation performance of the specimen under test.

9.2.1 For aircraft traffic noise sources, the incidence angle at closest approach, Φ, can vary widely for each noise event. See Fig. 8. The noise level also varies significantly with time for each event. Measurements with aircraft noise sources may be restricted to component specimens such as roofs, ventilators, and to complete structure specimens that cannot be readily tested by other means. When flying aircraft provide the test noise, the angle Φ shall be reported. The outdoor free-field microphone method (like Fig. 4) is preferred (8)

9.3 Determination of Outdoor Traffic Noise Level:

9.3.1 *Traffic Noise Measurement at an Equivalent Distance* (Fig. 4)—This method is used with steady and uniform roadway traffic as a noise source. Measure the traffic noise sound pressure level, L , outdoors at a reference aperture (Fig. 4 inset), remote from any reflecting surfaces other than the ground, at the same distance as the test facade is from the traffic. The indoor and outdoor sound pressure levels shall be measured simultaneously as described in 9.5. If traffic is non-uniform, or if over flying aircraft are used as the noise source, the average of the indoor noise level and the outdoor noise level, or the SEL of each, must each properly represent each vehicle passage. See 9.5.

9.3.2 *Traffic Noise Measurement at the 2 m, Position* (Fig. 5)—Measure the traffic noise outdoors at a point opposite the center of the facade element under test, at a distance of 2 m from the outermost portion of the facade. If there are major protrusions such as balconies, the test point shall be 2 m outside the protruding section, and the protrusion should be identified as part of the specimen under test.

9.3.3 *Traffic Noise Measurement at the Flush Position* (Fig. 6)—This method may be used when the facade is smooth or if only one element of a facade such as a window is the specimen under test. Measure the traffic noise outdoors flush with the specimen surface at its center and preferably at up to four more points about the specimen surface. Use a small diameter microphone according to 8.3.3.

9.4 *Determination of Indoor Sound Pressure Level*—The indoor measurement positions shall be as described in 8.4 with the exception that if a room volume is less than 150 m³, a single microphone position located from 1.2 to 1.5 m above the floor may be used. Its exact location with respect to the specimen under test shall be reported. For measurement procedures, see 9.5.

9.5 *Measurement Procedures for Fluctuating Traffic Noise*—Measure the average sound pressure level of all fluctuating noises using an integrating averaging sound level meter meeting the requirements of ANSI S1.43 or IEC 61672. Outdoor and indoor measurements must be averaged over the same time interval (see 8.1.3). When fixed microphone positions are used, measurements shall be made simultaneously for all microphones.

9.5.1 The outdoor free field microphone method (like Fig. 4 is preferred (8)). If only the A-weighted noise reduction due to the actual source is desired, ASEL measurements may be used instead of one-third octave-band measurements. For aircraft flyover noise or where natural traffic is sparse, simultaneously measure both the outdoor and the indoor one-third octave-band sound exposure level, one-third octave-band SEL(f) of individual events. Reject outliers such as flyovers where $\phi \geq 90^\circ$. Compute a single OINR(line,φ) value at each frequency from the sum of all of the exterior SEL(f) values accepted vs the sum of all the corresponding interior SEL(f) values, according to Eq 7 as follows: For each frequency, “f”, and for “j” overflights where “i” is the ith overflight indexed from 1 through j; $SELO_{f,i}$ is the ith overflight outdoor noise SEL and $SELI_{f,i}$ is the corresponding ith overflight room interior noise SEL.

$$OINR_j(\text{line}, \phi) = 10 * \text{Log}[SUM_j (10^{(SELO_{f,i} / 10)})] \quad (7)$$

$$- 10 * \text{Log}[SUM_j (10^{(SELI_{f,i} / 10)})] - C$$

where C , according to the outdoor microphone position, is either 0 (calibrated loudspeaker), or 2 (near the façade) or 5 (flush).

NOTE 4—If the A-weighted noise reduction due to the actual source is reported, the result is called noise level reduction. See X1.1.2.1.

9.5.2 Background levels, outdoors and indoors, should also be verified before and after each measurement session. Corrections are made if necessary according to Section 10. Background levels may be established during periods of light road traffic or no aircraft traffic. Otherwise the OINR values measured must be reported as minimum values.

NOTE 5—An outdoor-indoor microphone pair can be used to measure OINR with a continuous traffic noise source. The level difference is measured, then the indoor microphone is moved and this procedure is repeated for each additional indoor microphone positions located according to 8.4.1.2.

9.6 Calculation of OINR for the Traffic Noise Methods:

9.6.1 *Remote Outdoor Sound Field Measurement* (see 9.3.1)—Calculate OINR as:

$$OINR(\text{line}) = L_{free} - L_{in} \quad (8)$$

where:

L_{free} = remote traffic outdoor sound pressure level, L_f and
 L_{in} = simultaneous space average sound pressure level in the receiving room.

9.6.2 *Outdoor Measurements at 2 m from the Facade* (see 9.3.2)—The presence of the façade approximately doubles the sound pressure near the façade (+3 dB), but in practice, this increase is found less; a 2 dB representation is used here. Calculate OINR as follows:

$$OINR (\text{line } \Phi) = L_{near} - L_{in} - 2 \text{ dB} \quad (9)$$

where:

L_{2m} = equivalent sound pressure level outdoors at a point 2 m (79 in.) from the facade test element, dB.

9.6.3 *Outdoor Sound Field Measurements Flush to the Facade* (see 9.3.3)—The presence of the façade approximately quadruples the sound pressure (+6 dB) on the specimen. But in practice, this increase is found to be about 5 dB (8). See also X1.1. Calculate OINR as follows:

$$OINR (\text{line}, \Phi) = L_{flush} - L_{in} - 5 \text{ dB} \quad (10)$$

NOTE 6—See Note 3.

10. Adjustments for Background Noise

10.1 Verify that the outdoor and indoor levels are from the designated test source (traffic or loudspeaker) and not from some extraneous background noise source. At each measurement position, the background level should be at least 5 dB below the level of signal and background combined. Adjustments shall be made unless the background level is more than 10 dB below the combined level. If the background level is between 5 and 10 dB below the combined signal and background combined, the adjusted value of the signal level is calculated as follows:

$$L_s = 10 * \log(10^{L_{sb}/10} - 10^{L_b/10}) \quad (11)$$

where:

L_b = Background noise level, dB,

L_{sb} = Level of signal and background combined, dB, and

L_s = Adjusted signal level, dB.

11. Instrumentation

11.1 *Measurements of Sound Pressure Level:*

11.1.1 *Loudspeaker Source Method*—An integrating-averaging sound level meter or equivalent instrumentation that meets Type 1 requirements of ANSI S1.43 or IEC 61672 is required for the methods in Section 8. Type 2 instrumentation may be used when traffic or aircraft sound sources are used provided the same calibrator and microphone types are used for both the indoor and the outdoor sound measurement systems.

11.1.2 *Traffic Noise Source*—Two similar microphone systems meeting the requirements of 11.1.1 are required for simultaneous measurement of indoor and outdoor levels for the method in Section 9.

11.1.3 *Windscreen*—The microphone should be fitted with a wind screen of such design that the system meets the Type 2 requirements for outdoor measurements. For the flush method described in 8.3.3, a modified foam windscreen partly cut away to permit placement of the microphone close to the surface may be used.

11.2 *Filters*—Filters for defining the frequency bands used shall meet the class 1 requirements or better of ANSI S1.11 for one-third octave-band and for octave-band filters.

11.3 *Calibration*—The calibration of all measurement systems shall be verified at one frequency before (and preferably after) each series of tests at a given site using a calibrator meeting class 2 requirements of ANSI S1.40 or IEC 60942.

12. Report

12.1 The test report should include the following:

12.1.1 Provide a statement, if true in every respect, that the test was performed in accordance with one of the methods described in this guide.

12.1.2 Describe the test site: the dimensions and construction of the facade, the dimensions and furnishings of the receiving room, whether the room was highly absorbent, and the condition of operable windows or doors (open or closed). If auxiliary tests are done, for example to investigate flanking transmission or to determine the sound transmission loss of a portion of the facade or if steps are taken to limit flanking through surfaces other than the one under the test, these procedures also shall be reported.

12.1.3 Cite the specific test method used and essential details of the test procedure. If the traffic noise method is used, describe the traffic flow and its location relative to the facade. If a loudspeaker source is used, report the characteristics of the loudspeaker and its location relative to the test façade and to any other exterior surface of the receiving room. If a calibrated loudspeaker source was used, report the method of test and free-field determination. If the flush microphone position is used, report the microphone type, orientation, and spacing to the facade exterior surface.

12.1.4 Identify the instruments used and the measurement and calibration procedures (including microphone calibration). For a time-varying noise source such as traffic, describe the method of determining equivalent sound pressure levels.

12.1.5 List results according to frequency and clearly identified as OINR, OITL(θ), or AOITL(θ).

12.1.6 Identify single number rating results as being either OINIC, FOITC(q) or AOITC(q) (see 3.2.1, 3.2.3 and 3.2.4). The single number rating, OITC, rates the effectiveness of a building facade element at reducing transportation noise intrusion. It is defined in Classification E1332. Only the TL values determined by Test Method E90 are used to calculate OITC. When a single number rating is calculated using the E1332 Classification method and the OITL(θ) values obtained here, it is termed “field” as FOITC(θ). When a single number rating is calculated using AOITL(θ) values obtained here, it is termed AOITC(θ).

12.1.7 Include the following statement in the report: “The results stated in this report represent only the specific construction and acoustical conditions present at the time of the test. Measurements performed in accordance with this standard on nominally identical constructions and acoustical conditions may produce different results.”

12.1.8 On each page of the report containing test results, place the following statement: “This page alone is not a complete report.”

13. Precision and Bias

13.1 *Precision*—No body of experience in the use of this guide exists at present; however, it is estimated that the

repeatability standard deviation of these test procedures are of the order of 2 to 3 dB, depending on frequency.

13.2 *Bias*—The bias of test methods referenced in this guide have not been established and await a round robin of OITL measurements.

13.3 The principal aspect of these test procedures that degrades precision and bias, especially for OITL(θ) calculation, is the measurement of L_{outdoor} the wide range of exterior sound field configurations.

14. Keywords

14.1 calibrated loudspeaker; doors; facade; flanking; noise reduction; outdoor noise field; outdoor-indoor level reduction; outdoor-indoor transmission loss; traffic noise; transmission loss; windows

ANNEX

(Mandatory Information)

A1. TESTS FOR ASSESSING FLANKING TRANSMISSION (PATHS OTHER THAN THROUGH THE SPECIMEN)

A1.1 Introduction:

A1.1.1 The formulas provided in this guide determine the outdoor-indoor transmission loss of the test specimen presuming that all the sound reaching the receiving room is transmitted through the specimen. In practical testing, some sound may find its way through adjacent elements (flanking transmission).

A1.1.2 To provide a better estimate of the true OITL(θ) of the test element alone, a flanking test is applied. The sound transmitted into the receiving room by flanking paths is identified by blocking the test specimen and repeating the measurement. Sound transmitted under this condition may be eliminated or corrections made for it.

A1.1.3 The tests given in A1.2 – A1.4 apply to a test specimen, which can be the entire facade, such as a wall, or to a test element which forms only part of that facade, such as a window. In applying this procedure to the test specimen (see the procedure in A1.3), specific attention is given to joints between the specimen and the remainder of the facade. If they are considered part of the specimen, then they must be covered.

A1.2 *Specimen and Perimeter Integrity*—This survey is recommended before proceeding to OINR or OITL(θ) measurements:

A1.2.1 To compare sound transmitted through the test facade or element to that transmitted elsewhere, survey the sound levels within a few millimetres of the various surfaces of the receiving room. This may be done with a stethoscope or a sound level meter, and headphones. A more revealing method is to sense the vibration of each room surface with a low mass vibration transducer placed on each of the room surfaces in turn. Identify major air leaks through joints or local defects with the open end of the air tube of a stethoscope, used as a probe at all such locations.

NOTE A1.1—In conducting the indoor airborne sound survey, there is a normal buildup of sound pressure near any reflecting surface (+ 3 dB) in the intersecting corner of any two (+ 6 dB) or three (+ 9 dB) reflecting surfaces.

A1.2.2 *Remedial Procedures*—Reduce significant sound transmission through surfaces or elements not included in the specimen. For example (unless it forms part of the test specimen), a leaky joint can be taped or caulked, a ventilator opening can be covered, or filler panels around windows or air conditioners may be made more massive. All remedial steps should be reported.

A1.3 Facade Flanking Test Procedure:

A1.3.1 *Blocking Panel*—Measure the apparent AOITL (θ) of the specimen as found. Cover the interior side of the specimen with an additional panel designed to reduce transmission through the specimen by at least 10 dB. A suitable construction consists of a layer of freestanding or lightly supported plywood or gypsum board weighing about 10 kg/m², spaced at least 100 mm (4 in.) from the test facade or element. Fill the space with soft sound absorbing material such as glass fiber batts. Seal all panel joints and perimeter with tape, gaskets, or caulking compound.

A1.3.2 *Repeat Tests*—Measure the AOITL (θ) of the modified specimen. Compare with the initial OITL measurement.

A1.3.3 *Assessment of Results*—If the AOITL (θ) of the modified specimen is at least 10 dB higher in every one-third octave band than the initially-measured OITL, then the initial measurements may represent the true AOITL (θ) of the specimen.

A1.3.3.1 If the difference in apparent AOITL (θ) is less than 5 dB, proceed to A1.4.

A1.3.3.2 If the difference is between 5 and 10 dB, estimate the true OITL (θ) by treating level measurements with the test element blocked off as background noise for the same outdoor level in each case (see Section 10). Adapting Eq 11:

$$L_s = 10 \log(10^{(L_{ab}/10)} - 10^{(L_b/10)}) \quad (\text{A1.1})$$

where:

L_b = Indoor level with the specimen blocked off,
 L_{ab} = Initial indoor level with specimen exposed, and

L_s = Adjusted indoor level due to transmission through the specimen alone.

A1.4 *Supplementary Flanking Tests*—If blocking the test specimen reduces the receiving room level by less than 5 dB, increase the transmission loss of the blocking panel or block off

other possible sound transmitting paths into the room. The tests given in A1.2 may provide guidance in choosing the next step. It is likely that it will be necessary to cover flanking paths to reduce the flanking noise, and then repeat the procedure starting at A1.3.1. The procedure given in A1.3 may be repeated until the requirements of A1.3.3 are met.

APPENDIX

(Nonmandatory Information)

X1. OTHER FACADE ATTENUATION MEASURING METHODS

INTRODUCTION

The United States Federal Highway Administration (FHWA) and Federal Aviation Administration (FAA) and consultants doing work for them have used variations on the methods presented in this guide. Other single number metrics for evaluating façades have been developed. These techniques are listed here only as historic references. They are not techniques included in this guide.

X1.1 Measurement Methods

X1.1.1 FHWA measurement methods:

X1.1.1.1 Current FHWA measurement guidance (10) is based on an earlier version of this guide using traffic as the source and measurements by either the remote measurement procedure or 2 meter procedure. Alternatively a loudspeaker source at 15 to 60 and preferably 45 degrees is suggested. The difference between the 2 m measurement and the free field result is assumed to be 3 dB in accordance with earlier versions of this guide. Time-average levels over a long time period are recommended. The A-weighted sound level difference is the preferred final result.

X1.1.1.2 An earlier measurement method developed for the FHWA (11) used road noise as the source with an outdoor microphone at the façade and a single indoor measurement location near the center of the room. The difference between the sound level on the surface and the free-field level was found to be 5 dB, corresponding to Eq 5 and Eq 10 of this guide. Time average sound levels were computed from slow response A-weighted sound levels sampled at 10 second intervals for 15 minutes. Suggested alternatives to road noise were a truck either idling or driving by, or a loudspeaker playing recorded traffic noise.

X1.1.2 FAA measurement methods:

X1.1.2.1 The primary FAA interest is the measurement of the façade noise reduction improvement achieved by modifications to structures. The FAA names the decibel difference between the A-weighted sound level measured in the free-field and the indoor sound level as the “noise level reduction”. The current recommended procedure (12) uses overflying aircraft as the source. The outdoor microphone must have a clear unobstructed view of the flight path. A pole in an adjacent yard or 3 m above the building roof is suggested. Two indoor microphones at least 1.2 m from any hard reflective surface are recommended but one is allowed. Several overflight event measurements are recommended, with SEL preferred but maximum levels allowed.

X1.1.2.2 Earlier FAA methods (13) used maximum sound levels with the outdoor microphone mounted approximately 40 mm from the façade and four microphone positions within the room. It was found with these methods that the difference between the free-field level and the level close to the façade was 5 dB.

X1.1.2.3 The FAA allows flexibility in methods especially when aircraft noise sources are not convenient. Loudspeakers have been used as the outdoor sound source, measuring the level reduction in one-third octave-bands and calculating the A-weighted level difference based on a typical aircraft spectrum. A method also has been developed with a loudspeaker inside since the primary concern is a difference in performance before and after modifications. (14) Measurements are made 0.3 m from the specimen surface inside and outside.

X1.2 Single Number Rating Methods

X1.2.1 Exterior wall noise rating, EWN_R (15) and External Wall Rating EWR—Associated with the measurement method described in X1.1.2.2 the FHWA sponsored development of the Exterior Wall Noise Rating, EWN_R. It was first shown based on data and reference to earlier research that a moving source provided enough variation in the angle of incidence that the cos θ term could be deleted from what is Eq 6 of this guide.

X1.2.1.1 An EWN_R rating curve was based on the concept that a material with a transmission loss curve matching it when exposed to a traffic noise spectrum would produce a resulting spectrum approximating an inverse A-weighting curve. The resulting rating curve has a slope of 6 dB per octave from 125 to 500 Hz, flat from 500 to 2000 Hz, and -6 dB from 2000 to 4000 Hz. It was proposed that by using an average value of room sound absorption, the A-weighted level reduction could be computed from:

$$A - \text{weighted level reduction} = \text{EWN}_R - 10 \log(S/A) - 6 \quad (\text{X1.1})$$

X1.2.2 Experimental data showed that the initial value read from the contour curve at 500 Hz had to be reduced by 4 dB to

give the best correlation for typical traffic noise or 6 dB to correlate with aircraft noise of the era. This factor was

incorporated into the EWNRR. The value read from the curve at 500 Hz was then defined as the External Wall Rating EWR.

REFERENCES

- (1) Donovan, P. R., Flynn, D. R., and Yaniv, S. L., “Highway Noise Criteria Study: Outdoor/Indoor Noise Isolation,” *Technical Note* 1113-2, National Bureau of Standards, 1980.
- (2) Jones, R. E., “Intercomparisons of Laboratory Determinations of Airborne Sound Transmission Loss,” *Journal of the Acoustical Society of America*, Vol 66, 1970, pp. 148–164.
- (3) Quint, J. D., “Acoustic Insulation Factor: A Rating for the Insulation of Buildings Against Outdoor Noise,” *Building Research Note 148*, June 1979 (Revised June 1980), National Research Council, Canada.
- (4) Cremer, L. and Heckel, M. *Structure-Borne Sound*, Springer-Verlag, 1988, Chapter VI, Part 6.
- (5) Ver, I. and Holmer, C. *Noise and Vibration Control*, 1971, Institute of Noise Control Engineers, Chapter 11, pp 281–283.
- (6) Waterhouse, R. V., “Interference Patterns in Reverberant Sound Fields,” *Journal of the Acoustical Society of America*, Vol 27, 1955, pp. 247–258.
- (7) Nash, A., “Facade Sound Insulation—A Field Study,” *Inter-Noise 84 Proceedings*, Noise Control Foundation, Poughkeepsie, NY, pp. 593–596.
- (8) Bradley, J. S. and Chu, W. T., Errors When using Façade Measurements of Incident Aircraft Noise, 2002 International Congress and Exposition on Noise control engineering, Dearborn, MI, August 19-21. 2002
- (9) Lewis, P. T., “A Method for Field Measurements of the Transmission Loss of Building Facades,” *Journal of Sound and Vibration*, Vol 33, Part 2, 1974, pp. 127–141.
- (10) Lee, C.S.Y. and Fleming, G. G., “Measurement of Highway Related Noise,” Chapter 8, *U. S. Department of Transportation Report No. FHWA-PD-96-046*, May, 1996.
- (11) Davy, B. A. and Skale, S.R., “Insulation of Buildings against Highway Noise,” *U. S. Department of Transportation Report No. FHWA-TS-77-202*, August 1, 1977 .
- (12) “Study of Soundproofing Public Buildings Near Airports,” Section 4.2.2, *U. S. Department of Transportation Report No. DOT-FAA-AEQ-77-9*, April 1977.
- (13) “Study of Soundproofing Public Buildings Near Airports,” Report No. DOT-FAA-AEQ-77-9, April 1977 .
- (14) Gurovich, Y. A. and Ehrlich, G., Façade Sound Insulation Testing using Aircraft and Loudspeaker Techniques, 2004 International Congress and Exposition on Noise control engineering, Prague, Czech Republic, August 22-25. 2004.
- (15) Mange, G. E., Skale, S. R., and Sutherland L. C., “Background Report on Outdoor-Indoor Noise Reduction Calculation Procedures Employing the Exterior Wall Noise Rating (EWNRR) Method,” *U. S. Department of Transportation Report No. FHWA-TS-77-220*, March, 1978.

ASTM International takes no position respecting the validity of any patent rights asserted in connection with any item mentioned in this standard. Users of this standard are expressly advised that determination of the validity of any such patent rights, and the risk of infringement of such rights, are entirely their own responsibility.

This standard is subject to revision at any time by the responsible technical committee and must be reviewed every five years and if not revised, either reapproved or withdrawn. Your comments are invited either for revision of this standard or for additional standards and should be addressed to ASTM International Headquarters. Your comments will receive careful consideration at a meeting of the responsible technical committee, which you may attend. If you feel that your comments have not received a fair hearing you should make your views known to the ASTM Committee on Standards, at the address shown below.

This standard is copyrighted by ASTM International, 100 Barr Harbor Drive, PO Box C700, West Conshohocken, PA 19428-2959, United States. Individual reprints (single or multiple copies) of this standard may be obtained by contacting ASTM at the above address or at 610-832-9585 (phone), 610-832-9555 (fax), or service@astm.org (e-mail); or through the ASTM website (www.astm.org). Permission rights to photocopy the standard may also be secured from the Copyright Clearance Center, 222 Rosewood Drive, Danvers, MA 01923, Tel: (978) 646-2600; http://www.copyright.com/