



Standard Specification for Sampling Single-Phase Geothermal Liquid or Steam for Purposes of Chemical Analysis¹

This standard is issued under the fixed designation E947; the number immediately following the designation indicates the year of original adoption or, in the case of revision, the year of last revision. A number in parentheses indicates the year of last reapproval. A superscript epsilon (ϵ) indicates an editorial change since the last revision or reapproval.

1. Scope

1.1 This specification covers the basic requirements for equipment to be used for the collection of uncontaminated and representative samples from single-phase geothermal liquid or steam. Geopressured liquids are included. See Fig. 1.

2. Referenced Documents

2.1 *ASTM Standards*:²

D1192 Guide for Equipment for Sampling Water and Steam in Closed Conduits (Withdrawn 2003)³

3. Application

3.1 This specification covers only that equipment which is commonly used for the sampling of single-phase geothermal liquid or steam. It does not cover specialized equipment required for, and unique to, a specific test or method of analysis. The specification covers items such as valves, fittings, tubing, cooling coils and condensers, pumps, degassers, sample containers, sample probes, and packaging materials, but excludes equipment used in specific testing and analysis.

3.2 This procedure applies to single-phase steam or liquid streams prior to separation and to separated single-phase steam or liquid streams.

3.3 For most geothermal and geopressured fluids tested by the procedures outlined in this specification, both liquid and gas samples may be collected.

4. Sample Probes

4.1 Sample probes shall be used to extract liquid or steam from the main part of the geothermal flow rather than using a wall-accessing valve and pipe arrangement.

¹ This specification is under the jurisdiction of ASTM Committee E44 on Solar, Geothermal and Other Alternative Energy Sources and is the direct responsibility of Subcommittee E44.15 on Geothermal Field Development, Utilization and Materials.

Current edition approved March 1, 2015. Published April 2015. Originally approved in 1983. Lasts previous edition approved in 2007 as E947-83(2007). DOI: 10.1520/E0947-83R15.

² For referenced ASTM standards, visit the ASTM website, www.astm.org, or contact ASTM Customer Service at service@astm.org. For *Annual Book of ASTM Standards* volume information, refer to the standard's Document Summary page on the ASTM website.

³ The last approved version of this historical standard is referenced on www.astm.org.

4.1.1 The probe permits the sampling of various positions within the flow to determine whether stratified or annular two-phase flow is present which would bias a single-point sample.

4.2 Sample probes shall be designed to extract representative samples from flowing systems. Special attention during construction of the probe shall be given to the stresses that the probe will later be subjected to during insertion into, and operation in, a pressurized flowing system.

4.3 The sampling probe (see Fig. 2) passes through the sliding seal and access valve in order that liquid or steam can be sampled from the mainstream of the flow line. Thereafter, the sample contacts only surfaces that the operator can verify are noncontaminating and nonabsorbing.

4.3.1 Moving the probe tip across the diameter of the pipe may allow the operator to determine the existence of stratification or multiphase sampling problems.

4.3.2 Flow regulation is accomplished downstream of the cooling coils in order to avoid residual flashing into steam at the point of pressure reduction. Flashing may cause scale deposition which would preclude the accurate determination of certain constituents.

5. Sampling Lines

5.1 *Safety*—Sampling lines shall be as short as practical and of sufficient strength to prevent structural failure.

5.2 *Construction*—All sample lines shall be constructed to eliminate traps in which condensate, entrained particulates, or scale precipitates might settle since they may be partially emptied with changes in flow conditions and may result in sample contamination. Allow for thermal expansion.

6. Valves, Fittings, and Gages

6.1 Valves which control access to the sampling point shall have straight throats (frequently designated as ball, plug, and gate valves). This permits a probe to be inserted directly into the flow.

6.2 It is recommended that at least one full-port shut-off valve be placed on the downstream end of the sample probe so that the sampling line may be isolated when desired.

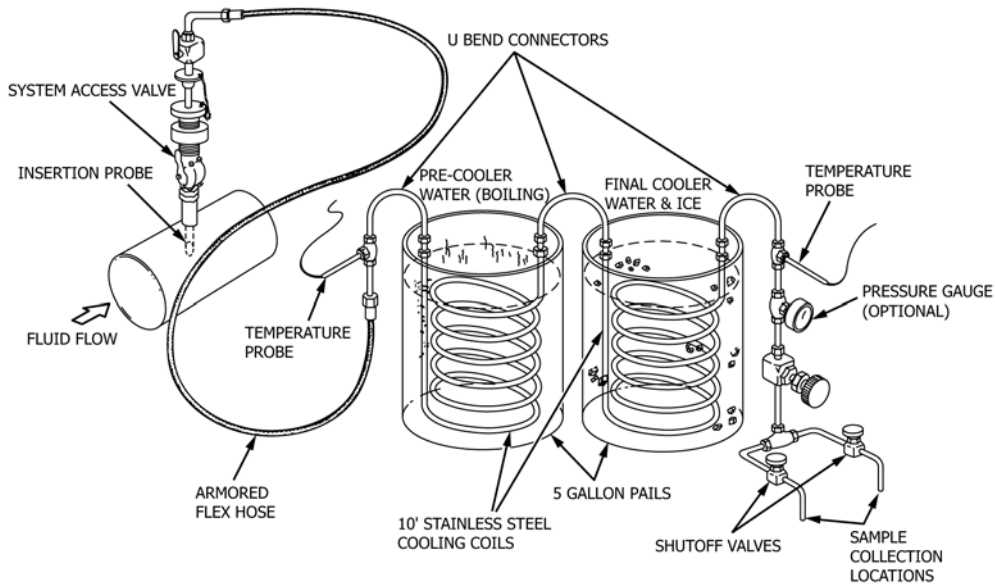

FIG. 1 Example Assembly (Particularly Suited for Liquid Flows)

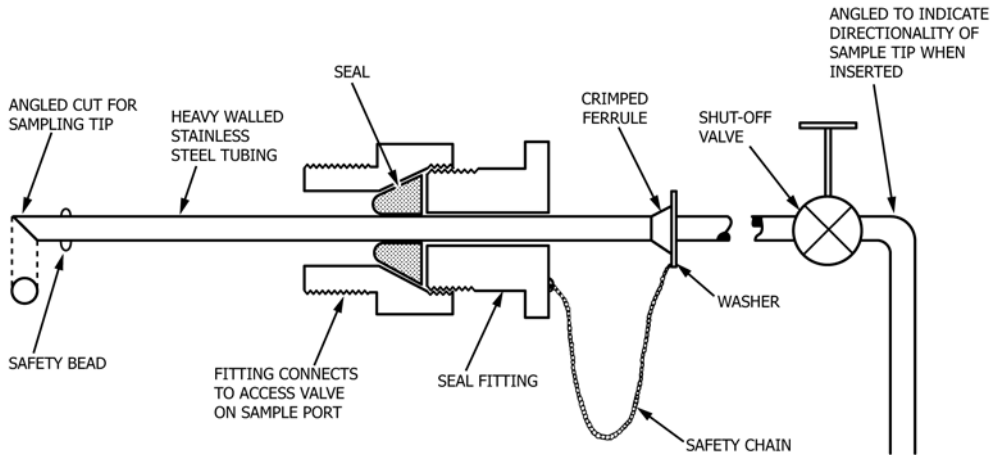

FIG. 2 Sample Probe

6.3 Throttling devices such as valves, capillary tubes, or orifices, if used, shall be placed at the sample outlet of the cooler or condenser. This practice will ensure cooling at the highest pressure and will minimize the possibility of fluid flashing or scale forming in the cooling coil. A head column such as that recommended for normal water and steam sampling (Specification D1192, for Equipment for Sampling Water and Steam) shall not be used because it provides a mechanism for gas separation and escape prior to sample collection.

6.4 Equipment adequate to determine the pressure and temperature of the mainstream liquid or steam flow shall be utilized.

7. Sample Cooler

7.1 The tube through which the sample flows shall be continuous through the cooling location so there will be no possibility of sample contamination or dilution from the cooling water. The internal diameter of the tube is suggested to be no larger than that of the sample probe so that storage within

the coil is low and the time lag of sample through the cooling phase will be a minimum.

7.2 When the temperature of the sample is above the boiling point of water, it may be advantageous, in order to conserve ice, to use a pre-cooler containing water to lower the temperature of the sample before it enters the cooler. The temperature of the sample can then be controlled by the flow rate and the temperature of the final cooling bath (frequently an ice water bath).

8. Materials and Lubricants

8.1 Lubricants:

8.1.1 No lubricant shall be used in the collection containers, or their valves and seals, where it could contact the sample and bias the components of interest. This is particularly important if minor constituents are to be measured.

8.1.2 Other valves and moving parts in the sampling equipment that contact the sample should be lubricated to the minimum extent consistent with service life.

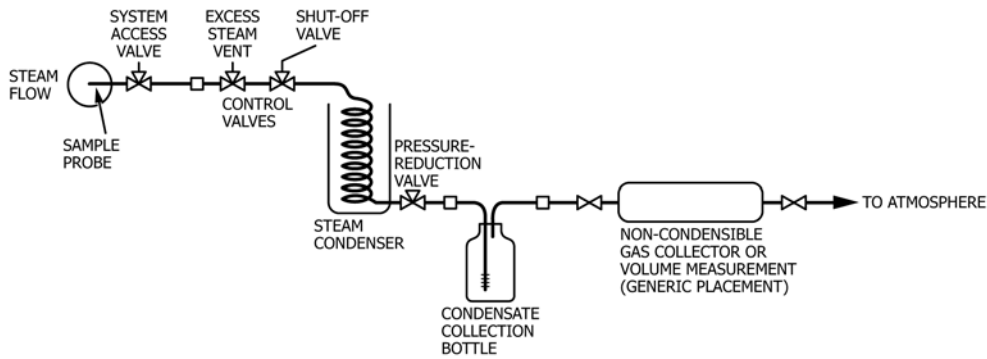

FIG. 3 Example Assembly (Particularly Suited for Steam Flows)

8.2 *Materials:*

8.2.1 In all cases, the sampling equipment shall be made of materials resistant to corrosion by the sample and that will not bias the results. Stainless steel, glass, and polymers are examples of materials that are generally satisfactory.

8.2.2 Copper-based alloys should be avoided.

9. **Liquid Sample Containers**

9.1 Liquid sample containers and compatible closures shall not bias the sample components of interest. Sample containment shall conform to EPA guidelines.⁴ These guidelines recommend the collection of liquid samples in either plastic or glass containers. Boron and silica samples should be collected in plastic containers.

9.2 The closures of the filled sample containers shall be fixed in place to prevent accidental opening in transit. Alternatively, the sample containers may be secured inside a shipping container designed to prevent disturbance of the inner container.

10. **Gas Sample Containers**

10.1 Devices used to collect and transport the gas component of the samples (as shown in Fig. 3) shall be resistant to chemical reactions and to gaseous diffusion or adsorption. They should be filled to equal or exceed atmospheric pressure to prevent air from leaking into the sample container.

11. **Filters**

11.1 Filters, when used, shall be housed in a pressure-tight container assuring that the full flow passes through the filter.

12. **Cleaning**

12.1 The sampling apparatus shall be kept clean.

12.2 When finished sampling, or when the sampling apparatus will be idle, the interior of the apparatus shall be rinsed with distilled water to minimize corrosion and contamination.

12.3 It may be necessary to disassemble and clean new equipment prior to initial use.

13. **Example of Sampling Train**

13.1 Examples of a sampling train are shown in Fig. 1 and Fig. 3. Consideration should be given to the force generated by any specific combination of probe diameter and system pressure and to the limitations and safety of sliding seals. A combination of probe tip bead and safety chain are recommended to restrict forcible ejection of the probe from the line being sampled. In unsafe cases, a fixed connection is preferred.

14. **Keywords**

14.1 chemical analysis; geopressured liquid; geothermal liquid; geothermal steam; single-phase geothermal liquid; single-phase geothermal steam

⁴ Federal Register, Vol 44, No. 244, pp. 75050–75052.

ASTM International takes no position respecting the validity of any patent rights asserted in connection with any item mentioned in this standard. Users of this standard are expressly advised that determination of the validity of any such patent rights, and the risk of infringement of such rights, are entirely their own responsibility.

This standard is subject to revision at any time by the responsible technical committee and must be reviewed every five years and if not revised, either reapproved or withdrawn. Your comments are invited either for revision of this standard or for additional standards and should be addressed to ASTM International Headquarters. Your comments will receive careful consideration at a meeting of the responsible technical committee, which you may attend. If you feel that your comments have not received a fair hearing you should make your views known to the ASTM Committee on Standards, at the address shown below.

This standard is copyrighted by ASTM International, 100 Barr Harbor Drive, PO Box C700, West Conshohocken, PA 19428-2959, United States. Individual reprints (single or multiple copies) of this standard may be obtained by contacting ASTM at the above address or at 610-832-9585 (phone), 610-832-9555 (fax), or service@astm.org (e-mail); or through the ASTM website (www.astm.org). Permission rights to photocopy the standard may also be secured from the Copyright Clearance Center, 222 Rosewood Drive, Danvers, MA 01923, Tel: (978) 646-2600; http://www.copyright.com/