



# Standard Specification for Glass Stopcocks with Polytetrafluoroethylene (PTFE) Plugs<sup>1</sup>

This standard is issued under the fixed designation E911; the number immediately following the designation indicates the year of original adoption or, in the case of revision, the year of last revision. A number in parentheses indicates the year of last reapproval. A superscript epsilon ( $\epsilon$ ) indicates an editorial change since the last revision or reapproval.

## 1. Scope

1.1 This specification covers standard dimensional requirements for obtaining, within practical limits, interchangeability in glass stopcocks (**Note 1**) with polytetrafluoroethylene (PTFE) plugs for ordinary laboratory and industrial applications. It covers dimensional interchangeability only and does not involve design characteristics of the item except where specified, nor does it involve physical or chemical characteristics of the material used. It does not cover glass stopcocks with glass plugs (**Note 2**) or stopcocks intended for use in high-vacuum work.

**NOTE 1**—A stopcock is defined as consisting of a plug and barrel in assembled configuration.

**NOTE 2**—Glass stopcocks with glass plugs are covered by Specification **E675**.

**NOTE 3**—The dimensions pertaining to stopcocks were taken from the now obsolete Commercial Standard CS 21-58 of the U.S. Department of Commerce and Product Standard PS 28-70 published by the National Bureau of Standards.

**NOTE 4**—Although glass is the most common material for stopcocks, other materials may be used as specified. Stopcocks constructed from glass shall be in accordance with Specifications **E438** and **E671**.

## 2. Referenced Documents

### 2.1 ASTM Standards:<sup>2</sup>

**D374** Test Methods for Thickness of Solid Electrical Insulation (Withdrawn 2013)<sup>3</sup>

**D1457** Specification for Polytetrafluoroethylene (PTFE) Molding and Extrusion Materials (Withdrawn 1996)<sup>3</sup>

**E438** Specification for Glasses in Laboratory Apparatus

**E671** Specification for Maximum Permissible Thermal Residual Stress in Annealed Glass Laboratory Apparatus

**E675** Specification for Interchangeable Taper-Ground Stopcocks And Stoppers

<sup>1</sup> This specification is under the jurisdiction of ASTM Committee **E41** on Laboratory Apparatus and is the direct responsibility of Subcommittee **E41.01** on Laboratory Ware and Supplies.

Current edition approved June 1, 2015. Published July 2015. Originally approved in 1982. Last previous edition approved in 2009 as E911 – 98 (2009). DOI: 10.1520/E0911-98R15.

<sup>2</sup> For referenced ASTM standards, visit the ASTM website, [www.astm.org](http://www.astm.org), or contact ASTM Customer Service at [service@astm.org](mailto:service@astm.org). For *Annual Book of ASTM Standards* volume information, refer to the standard's Document Summary page on the ASTM website.

<sup>3</sup> The last approved version of this historical standard is referenced on [www.astm.org](http://www.astm.org).

**E920** Specification for Commercially Packaged Laboratory Apparatus

**E921** Specification for Export Packaged Laboratory Apparatus

**E1133** Practice for Performance Testing of Packaged Laboratory Apparatus for United States Government Procurements

**E1157** Specification for Sampling and Testing of Reusable Laboratory Glassware

2.2 *Other Standard:*<sup>4</sup>

**PS 28-70** Glass Stopcocks With Polytetrafluoroethylene (PTFE) Plugs

## 3. Material

3.1 The PTFE material used to manufacture the plugs shall be in accordance with the requirements of Specification **D1457** Types I and IV, extrusion and molding grade resins.

## 4. Requirements for Single Straight-Bore Stopcocks

4.1 The designations and dimensions for single straight-bore stopcocks are shown in **Fig. 1** and **Table 1**.

4.2 *Taper* (**Note 3**)—All straight-bore stopcocks shall have a taper of  $2 \pm 0.006$  mm of diameter per 10 mm of length (1 to 5).

**NOTE 5**—The lines of contact of the mating surfaces should form a conical section having a taper of  $2 \pm 0.006$  mm per 1 cm of axial length (before compression of the plug surface) for an axial distance of at least 10 mm on each side of the bore.

## 5. Requirements for Single Oblique-Bore Stopcocks

5.1 The designations and dimensions for single oblique-bore stopcocks are shown in **Fig. 2** and **Table 2**.

5.2 *Taper* (**Note 4**)—All single oblique-bore stopcocks shall have a taper of  $2 \pm 0.006$  mm of diameter per 10 mm of length (1 to 5).

## 6. Requirements for Double Oblique-Bore (3-Way) Stopcocks

6.1 The designations and dimensions for double-oblique-bore stopcocks are shown in **Fig. 3** and **Table 3**.

<sup>4</sup> Commercial Standards and Product Standards are available from National Institute of Standards and Technology (NIST), 100 Bureau Dr., Stop 1070, Gaithersburg, MD 20899-1070, <http://www.nist.gov>.

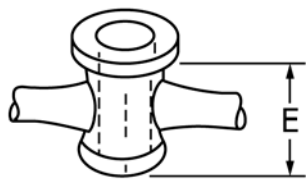

FIG. 1 Stopcock

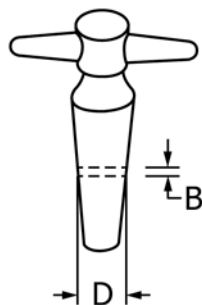

TABLE 1 Single Straight-Bore Stopcocks

Stopcock Designation and Bore of Hole in Plug B, mm	Diameter of Plug at Centerline of Bore D, mm	Length of Shell E, mm
1	11 ± 0.06	25 ± 0.5
2	11 ± 0.06	25 ± 0.5
3	15.2 ± 0.10	30 ± 0.5
4	15.2 ± 0.10	30 ± 0.5
6	16 ± 0.20	35 ± 0.5

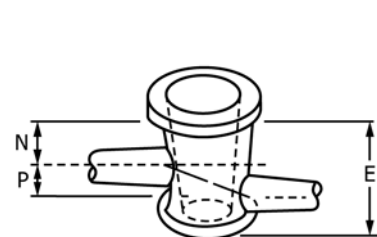

FIG. 2 Single Oblique-Bore Stopcock

TABLE 2 Single Oblique-Bore Stopcocks

Stopcock Designation and Bore of Hole in Plug B, mm	Diameter of Plug at Centerline of Hole near Large End D, mm	Length of Shell E, mm	Axial Distance from Large End of Shell to Hole at D N, mm	Axial Distance Between Bore Holes P, mm
2	15.9 ± 0.20	30 ± 0.5	11.5 ± 0.5	8 ± 0.5

6.2 *Taper (Note 3)*—All double oblique-bore (3-way) stopcocks shall have a taper of  $2 \pm 0.006$  mm of diameter per 10 mm of length (1 to 5).

## 7. Requirements for T-Bore and 120° Bore Stopcocks

7.1 These stopcocks are designated by the nominal bore size. With the exception of the bore sizes, the dimensions and tolerances for 1 and 2-mm T-bore and 120° bore stopcocks are the same as for the 4-mm single straight-bore stopcocks. Dimensions and tolerances for 3 and 4-mm T-bore and 120° bore stopcocks are the same as for the 6-mm single-bore stopcocks (see Table 1).

7.2 *Taper (Note 3)*—All T-bore and 120° bore stopcocks shall have a taper of  $2 \pm 0.006$  mm of diameter per 10 mm of length (1 to 5).

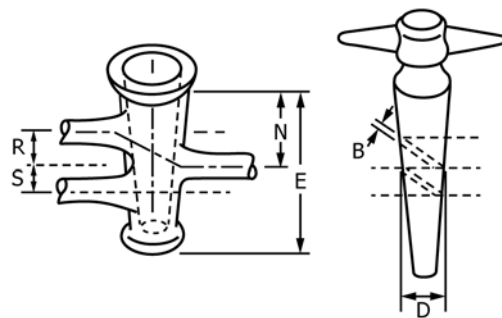

FIG. 3 Double Oblique-Bore (3-Way) Stopcock

## 8. Test Methods

8.1 *Dimensions*—Determine dimensions in accordance with Method B of Test Methods D374, except that micrometre calipers graduated to 0.01 mm shall be used.

8.2 *Taper*—Measure taper by using a sine bar and plate or an air gage.

8.3 *Leak Rate*—Use the leak test apparatus illustrated in Fig. 4, or one functionally similar to it. Suspend weights of 500 to 1500 g from the test plug to apply downward force for properly seating the plug in the barrel. Conduct the test as follows:

8.3.1 Check the apparatus setup, Fig. 1, for any leakage under the test conditions before testing any stopcocks, T.

8.3.2 Clean all surfaces of plug and shell with lint-free tissue or rinse with acetone.

8.3.3 Firmly seat the plug into the shell by rotating the plug. Remove the plug and repeat cleaning of both surfaces.

8.3.4 Attach stopcock T to rubber tubing R, and secure the connection.

8.3.5 Mount stopcock T horizontally so that the plug handle will be on top.

8.3.6 Gently reseat the plug into the shell in a closed position without applying tension or pressure.

8.3.7 Suspend weight W under the tested plug in such a manner that the gravitational force is applied uniformly.

8.3.8 Turn stopcock A to connect the source of vacuum and bulb B; then evacuate to 0-mm reading on scale S of the closed-end manometer, M. Tap the manometer gently before reading.

8.3.9 Turn stopcock A clockwise to connect stopcock T to vacuum, thus evacuating the stem to the test stopcock.

8.3.10 Turn stopcock A clockwise to connect stopcock T to bulb B.

8.3.11 Time for 60 s and then turn stopcock A counter-clockwise to isolate the manometer from stopcock T and vacuum source.

8.3.12 Tap manometer M gently; then measure and record the pressure change (in millimetres of mercury or kilopascals) of scale S.

8.4 *Performance*—Evaluate the stopcocks for performance in accordance with 8.3 using the test apparatus illustrated in Fig. 4. The 1, 2, 3, and 4-mm straight-bore stopcocks shall be considered acceptable if the manometer reading indicates a pressure increase of not more than 30-mm Hg (4 kPa), after 60 s with downward force applied by a 500-g weight. All other

TABLE 3 Double Oblique-Bore (3-Way) Stopcocks

Stopcock Designation and Bore of Hole in Plug <i>B</i> , mm	Diameter of Plug at Centerline of Openings at Center of Plug <i>D</i> , mm	Length of Shell <i>E</i> , mm	Axial Distance from Large End of Shell to Openings at <i>D</i> <i>N</i> , mm	Axial Distance from Openings at Center to Opening Nearest Large End <i>R</i> , mm	Axial Distance from Openings at Center to Opening Nearest Small End <i>S</i> , mm
1	12.9 ± 0.06	44 ± 0.5	22 ± 0.5	9.4 ± 0.5	8.1 ± 0.5
2	12.9 ± 0.06	44 ± 0.5	22 ± 0.5	9.4 ± 0.5	8.1 ± 0.5
3	14.4 ± 0.10	44 ± 0.5	22 ± 0.5	10.4 ± 0.5	9.0 ± 0.5
4	14.4 ± 0.10	44 ± 0.5	22 ± 0.5	10.4 ± 0.5	9.0 ± 0.5

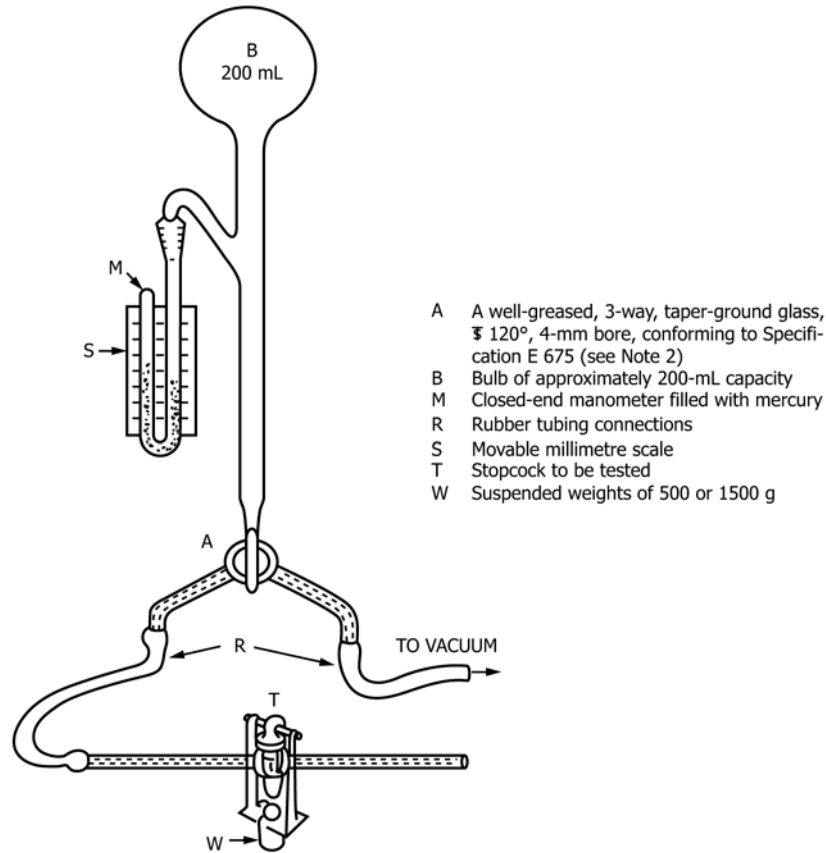

FIG. 4 Schematic Representation of Leak Test Apparatus

stopcocks shall be considered acceptable if the manometer reading indicates a pressure increase of not more than 30 mm Hg after 60 s with downward force applied by a 1500-g weight.

## 9. Marking

9.1 Interchangeable glass stopcocks with PTFE plugs conforming to this specification shall be marked on the glass barrel with the symbol  $\overset{P}{S}$ , the size designation, and trademark of the manufacturer or distributor. This symbol is the manufacturer's assurance to purchasers that the item identified by the symbol is a standard interchangeable size and type described and is manufactured within the tolerances permitted by this speci-

fication. It shall not be used on stopcocks nor in advertising description of stopcocks or PTFE plugs of any size or type other than those described in this specification.

## 10. Sampling and Testing

10.1 For sampling and testing refer to Specification E1157.

## 11. Packaging

11.1 For packaging, select from Specification E920, Specification E921, or Practice E1133.

## 12. Keywords

12.1 glass; PTFE; stopcocks

 **E911 – 98 (2015)**

*ASTM International takes no position respecting the validity of any patent rights asserted in connection with any item mentioned in this standard. Users of this standard are expressly advised that determination of the validity of any such patent rights, and the risk of infringement of such rights, are entirely their own responsibility.*

*This standard is subject to revision at any time by the responsible technical committee and must be reviewed every five years and if not revised, either reapproved or withdrawn. Your comments are invited either for revision of this standard or for additional standards and should be addressed to ASTM International Headquarters. Your comments will receive careful consideration at a meeting of the responsible technical committee, which you may attend. If you feel that your comments have not received a fair hearing you should make your views known to the ASTM Committee on Standards, at the address shown below.*

*This standard is copyrighted by ASTM International, 100 Barr Harbor Drive, PO Box C700, West Conshohocken, PA 19428-2959, United States. Individual reprints (single or multiple copies) of this standard may be obtained by contacting ASTM at the above address or at 610-832-9585 (phone), 610-832-9555 (fax), or [service@astm.org](mailto:service@astm.org) (e-mail); or through the ASTM website ([www.astm.org](http://www.astm.org)). Permission rights to photocopy the standard may also be secured from the Copyright Clearance Center, 222 Rosewood Drive, Danvers, MA 01923, Tel: (978) 646-2600; <http://www.copyright.com/>*