



Standard Practice for Measuring Colorimetric Characteristics of Retroreflectors Under Nighttime Conditions¹

This standard is issued under the fixed designation E811; the number immediately following the designation indicates the year of original adoption or, in the case of revision, the year of last revision. A number in parentheses indicates the year of last reapproval. A superscript epsilon (ϵ) indicates an editorial change since the last revision or reapproval.

1. Scope

1.1 This practice describes the instrumental determination of retroreflected chromaticity coordinates of retroreflectors. It includes the techniques used in a photometric range to measure retroreflected (nighttime) chromaticity with either a telecolorimeter or telespectroradiometer.

1.2 This practice covers the general measurement procedures. Additional requirements for specific tests and specifications are described in Section 7.

1.3 The description of the geometry used in the nighttime colorimetry of retroreflectors is described in Practice E808 and the methods for calculation of chromaticity are contained in Practice E308.

1.4 *This standard does not purport to address all of the safety concerns, if any, associated with its use. It is the responsibility of the user of this standard to establish appropriate safety and health practices and determine the applicability of regulatory limitations prior to use.*

2. Referenced Documents

2.1 *ASTM Standards:*²

E284 Terminology of Appearance

E308 Practice for Computing the Colors of Objects by Using the CIE System

E691 Practice for Conducting an Interlaboratory Study to Determine the Precision of a Test Method

E808 Practice for Describing Retroreflection

E809 Practice for Measuring Photometric Characteristics of Retroreflectors

2.2 *CIE Documents:*³

CIE Publication No. 15.2 Colorimetry, 2d ed.

CIE Standard S 001/ISO IS 10526, Colorimetric Illuminants

CIE Standard S 002/ISO IS 10527, Colorimetric Observers

CIE Technical Report 54.2 Retroreflection: Definition and Measurement

3. Terminology

3.1 The terms and definitions in Terminology E284 apply to this practice.

3.2 *Definitions:*

3.2.1 *chromaticity coordinates, n*—the ratios of each of the tristimulus values of a psychophysical color to the sum of the tristimulus values.

3.2.1.1 *Discussion*—Chromaticity coordinates in the CIE 1931 system of color specification are designated by x , y , z and in the CIE 1964 supplementary system by x_{10} , y_{10} , z_{10} .

3.2.2 *CIE 1931 (x, y)-chromaticity diagram*—the chromaticity diagram for the CIE 1931 standard observer, in which the CIE 1931 chromaticity coordinates are plotted with x as the abscissa and y as the ordinate.

3.2.3 *CIE 1931 standard observer, n*—ideal colorimetric observer with color matching functions $\bar{x}(\lambda)$, $\bar{y}(\lambda)$, $\bar{z}(\lambda)$ corresponding to a field of view subtending a 2° angle on the retina; commonly called the “ 2° standard observer.” [CIE]^{B4}

3.2.3.1 *Discussion*—The color matching functions of the CIE 1931 standard observer are tabulated in Practice E308, CIE Publication No. 15.2, and CIE Standard S 002.

3.2.4 *CIE standard illuminant A, n*—colorimetric illuminant, representing the full radiation at 2855.6 K, defined by the CIE in terms of a relative spectral power distribution. [CIE]^B

3.2.4.1 *Discussion*—The relative spectral power distribution of CIE standard illuminant A is tabulated in Practice E308, CIE Publication No. 15.2, and CIE Standard S 001.

¹ This practice is under the jurisdiction of ASTM Committee E12 on Color and Appearance and is the direct responsibility of Subcommittee E12.10 on Retroreflection.

Current edition approved July 1, 2015. Published July 2015. Originally approved in 1981. Last previous edition approved in 2009 as E811 – 09. DOI: 10.1520/E0811-09R15.

² For referenced ASTM standards, visit the ASTM website, www.astm.org, or contact ASTM Customer Service at service@astm.org. For *Annual Book of ASTM Standards* volume information, refer to the standard’s Document Summary page on the ASTM website.

³ Available from U.S. National Committee of the CIE (International Commission on Illumination), C/o Thomas M. Lemons, TLA-Lighting Consultants, Inc., 7 Pond St., Salem, MA 01970, http://www.cie-usnc.org.

⁴ Stephenson, H. F., “The Colorimetric Measurement of Retroreflective Materials. Progress Report on International Exchange Tests,” *Proceedings of the CIE*, 18th Session (London), pp. 595–609, 1975.



3.2.5 *CIE standard source A, n*—a gas-filled tungsten-filament lamp operated at a correlated color temperature of 2855.6 K. [CIE]^B

3.2.6 *entrance angle, β , n*—the angle between the illumination axis and the retroreflector axis.

3.2.6.1 *Discussion*—The entrance angle is usually no larger than 90°, but for completeness its full range is defined as $0^\circ \leq \beta \leq 180^\circ$. In the CIE (goniometer) system β is resolved into two components, β_1 and β_2 . Since by definition β is always positive, the common practice of referring to the small entrance angles that direct specular reflections away from the photoreceptor as negative valued is deprecated by ASTM. The recommendation is to designate such negative values as belonging to β_1 .

3.2.7 *goniometer, n*—an instrument for measuring or setting angles.

3.2.8 *illumination axis, n—in retroreflection*, a line from the effective center of the source aperture to the retroreflector center.

3.2.9 *observation angle, n*—angle between the axes of the incident beam and the observed (reflected) beam, (*in retroreflection, α* , angle between the illumination axis and the observation axis).

3.2.10 *observation axis, n—in retroreflection*, a line from the effective center of the receiver aperture to the retroreflector center.

3.2.11 *retroreflection, n*—reflection in which the reflected rays are preferentially returned in directions close to the opposite of the direction of the incident rays, this property being maintained over wide variations of the direction of the incident rays. [CIE]^B

3.2.12 *retroreflective device, n*—deprecated term; use *retroreflector*.

3.2.13 *retroreflective sheeting, n*—a retroreflective material preassembled as a thin film ready for use.

3.2.14 *retroreflector, n*—a reflecting surface or device from which, when directionally irradiated, the reflected rays are preferentially returned in directions close to the opposite of the direction of the incident rays, this property being maintained over wide variations of the direction of the incident rays. [CIE, 1982]^B

3.2.15 *retroreflector axis, n*—a designated line segment from the retroreflector center that is used to describe the angular position of the retroreflector.

3.2.15.1 *Discussion*—The direction of the retroreflector axis is usually chosen centrally among the intended directions of illumination; for example, the direction of the road on which or with respect to which the retroreflector is intended to be positioned. In testing horizontal road markings the retroreflector axis is usually the normal to the test surface.

3.2.16 *retroreflector center, n*—a point on or near a retroreflector that is designated to be the center of the device for the purpose of specifying its performance.

3.2.17 *rotation angle, ϵ , n*—the angle in a plane perpendicular to the retroreflector axis from the observation halfplane to

the datum axis, measured counter-clockwise from a viewpoint on the retroreflector axis.

3.2.17.1 *Discussion*—Range: $-180^\circ < \epsilon \leq 180^\circ$. The definition is applicable when entrance angle and viewing angle are less than 90°. More generally, rotation angle is the angle from the positive part of second axis to the datum axis, measured counterclockwise from a viewpoint on the retroreflector axis.

3.2.17.2 *Discussion*—Rotation of the sample about the retroreflector axis while the source and receiver remain fixed in space changes the rotation angle (ϵ) and the orientation angle (ω_s) equally.

3.2.18 *spectroradiometer, n*—an instrument for measuring the spectral distribution of radiant energy or power.

3.2.19 *tristimulus colorimeter, n*—instrument that measures psychophysical color, in terms of tristimulus values, by the use of filters to convert the relative spectral power distribution of the illuminator to that of a standard illuminant, and to convert the relative spectral responsivity of the receiver to the responsivities prescribed for a standard observer.

3.2.19.1 *Discussion*—In some instruments, the filters may be combined into one set placed in the receiver; in such cases, caution should be observed when measuring fluorescent specimens.

3.2.20 *viewing angle, v , n—in retroreflection*, the angle between the retroreflector axis and the observation axis.

3.3 Definitions of Terms Specific to This Standard:

3.3.1 *telecolorimeter, n*—a tristimulus colorimeter equipped with collection optics for viewing a limited area at a distance from the instrument.

3.3.2 *telespectroradiometer, n*—a spectroradiometer equipped with collection optics for viewing a limited area at a distance from the instrument.

4. Summary of Practice

4.1 Two procedures are described in this practice (see also Practice E809). Procedure A is based on a calibrated light source, colored reference filters, a white reference standard and a telecolorimeter equipped with tristimulus filters. In this procedure, measurements of the incident light on the white standard at the specimen position are made using the colored filters and correction factors developed. Then the retroreflected light is measured under the test geometry and the corrected relative tristimulus values are computed. In Procedure B, spectral measurements are made of the incident light and of the retroreflected light under the test geometry required. From these spectral measurements, the relative tristimulus values are determined. In both procedures, the chromaticity coordinates x , y are based on the CIE 1931 Standard Color Observer.

5. Significance and Use

5.1 This practice describes a procedure for measuring the chromaticity of retroreflectors in a nighttime, that is, retroreflective, geometry of illumination and observation. CIE Standard Source A has been chosen to represent a tungsten automobile headlamp. Although the geometry must be specified by the user of this practice, it will, in general, correspond to the relationship between the vehicle headlamp, the

retroreflector, and the vehicle driver's eyes. Thus, the chromaticity coordinates determined by the procedures in this practice describe numerically the nighttime appearance of the retroreflector.⁵

6. Use of the CIE Chromaticity Diagram for the Specification of Color

6.1 *Tristimulus Values for a Colored Sample*—The spectral nature of the light coming to the eye from a retroreflector depends upon the spectral distribution of the radiation from the source, $S(\lambda)$, and a quantity proportional to the spectral reflectance of the retroreflector, $R(\lambda)$. For nighttime colorimetric measurements of retroreflectors, $S(\lambda)$ is Illuminant A. The spectral tristimulus values, \bar{x} , \bar{y} , and \bar{z} , the illuminant power $S(\lambda)$, and the reflectance quantity $R(\lambda)$ are used together to calculate three numbers, the tristimulus values X , Y , and Z as follows:

$$X = k \int_{380}^{740} S_A(\lambda) R(\lambda) \bar{x}(\lambda) d\lambda$$

$$Y = k \int_{380}^{740} S_A(\lambda) R(\lambda) \bar{y}(\lambda) d\lambda$$

$$Z = k \int_{380}^{740} S_A(\lambda) R(\lambda) \bar{z}(\lambda) d\lambda$$

where:

- $S_A(\lambda)$ = spectral power distribution of Illuminant A,
- $R(\lambda)$ = spectral reflectance factor of the sample, and
- $\bar{x}(\lambda)$, $\bar{y}(\lambda)$, $\bar{z}(\lambda)$ = color matching functions of the CIE standard observer.

$$100/k = \int_{380}^{740} S_A \bar{y}(\lambda) d\lambda$$

Integration of each curve across the visible region (380 to 740 nm) give the numerical value for the corresponding tristimulus value X , Y , or Z .

6.2 *Chromaticity Coordinates*—The chromaticity coordinates x , y , and z are computed from the tristimulus values X , Y , and Z as follows:

$$x = X/(X+Y+Z)$$

$$y = Y/(X+Y+Z)$$

$$z = Z/(X+Y+Z)$$

The normalization constant k in the equations for X , Y , and Z cancels out in calculating x , y , and z . Thus, x , y , and z express the color of the reflected light without regard to its intensity. Because the sum of x , y , and z is always equal to one, only two of these quantities are needed to describe the chromaticity of a light. The chromaticity coordinates x and y are chosen for this purpose.

6.3 *CIE 1931 (x, y) Chromaticity Diagram*—The chromaticity coordinates x and y can be plotted as shown in Practice

E308, Fig. 1. The outline in the figure encloses the entire range of combinations of x and y that correspond to real colors. The points at which monochromatic radiation of various wavelengths falls are indicated on this boundary, with the more nearly neutral colors being represented by points toward the center of the bounded region.

6.4 *Specifying Color Limits*—A color point representing the x and y chromaticity coordinates of a test sample can be located on the CIE diagram. A specification for a specific retroreflective color limit would require that the color point for a sample of this color fall within specified boundaries of the diagram. The area within these boundaries is referred to as a color area, and is defined exactly by specifying four sets of chromaticity coordinates in the specification.

6.5 *Daytime versus Nighttime Color Limits*—Different color limits are required to specify daytime and nighttime color. Nighttime and daytime color limits are different for two major reasons: the quality of the illuminating light and the geometry or direction of the illuminating light. Daytime color is viewed under a source of daylight quality, and nighttime color is viewed under Source A (a CIE source corresponding to an incandescent lamp, such as an automobile headlamp). Illumination in the daytime is from skylight, and diffusely reflected light is observed; illumination in the nighttime comes from a point very near the observer, and retroreflected light is observed.

7. Requirements to be Stated in Specifications

7.1 When stating colorimetric retroreflective requirements, the following requirements shall be given in the specification for the material:

7.1.1 Limits of the color area on the 1931 CIE chromaticity diagram (usually four pairs of chromaticity coordinates (x and y) are required to define an area on the diagram).

7.1.2 Chromaticity coordinate limits and spectral transmittance limits of the standard filter when Procedure A is used. (These may be specified by giving the filter glass type and thickness or the manufacturer's part number of the filter.)

7.1.3 Observation angle (α).

7.1.4 Entrance angle (β) and when required the components of the entrance angle β_1 , and β_2 . (When specifying entrance angles near 0° , care must be taken to prevent "white" specular reflection from entering the receptor. Therefore, instead of specifying 0° , the entrance angle is usually specified so that specular light is reflected away from the receptor.)

7.1.5 Rotation angle (ϵ) and the location of the datum mark, if random orientation of the test specimen is not suitable.

7.1.6 Observation distance (d).

7.1.7 Test specimen dimensions and shape.

7.1.8 Receptor angular aperture, usually either 6 min or 10 min of arc.

7.1.9 Source angular aperture, usually either 6 min or 10 min of arc.

7.1.10 Reference center of the retroreflector.

7.1.11 Reference axis of the retroreflector. (The reference axis is usually perpendicular to the surface of sheeting. In such complex devices as automobile or bicycle reflectors, the

⁵ Rennilson, J. J., "Chromaticity Measurements of Retroreflective Material Under Nighttime Geometry," *Applied Optics*, Vol 45, April 15, 1980.

reference axis and reference center may be defined with respect to the viewing direction.)

8. Apparatus

8.1 The apparatus shall consist of either a spectroradiometer equipped with collection optics or a telecolorimeter, a regulated light projector source, a goniometer sample holder, a photometric range, and calibration standards.

8.2 *Telecolorimeter*—The telecolorimeter shall be equipped with three or more filters having spectral transmittances such that the spectral products of CIE Illuminant A with CIE tristimulus functions \bar{x} , \bar{y} , and \bar{z} are each linear combinations of the spectral products of the instrument illumination, the instrument detector sensitivity, and the three or more filters transmittances.

8.2.1 Discussion—If the Instrument illumination matches CIE Illuminant A, then the condition simplifies to the CIE Tristimulus functions \bar{x} , \bar{y} , and \bar{z} each being linear combinations of the spectral products of the instrument detector sensitivity and the three or more filters transmittances.

8.2.2 *Stability and Linearity*—The linearity of the scale reading shall be within 1.0 % over the range to be measured.

8.2.3 *Light Filter Holder Attachment*—If the filter correction factor is to be used, the telecolorimeter shall be equipped with an attachment to mount filters in a way that prevents interreflection between the filter and the telecolorimeter.

8.2.4 *Means to Eliminate Stray Light*—Stray light shall be reduced to a negligible level by use of a field aperture on the telecolorimeter. The field aperture may be omitted if baffling of the photometric range is carefully employed. Elimination of stray light is particularly important when a photometer-type instrument is used.

8.3 *Spectroradiometer*—The spectroradiometer shall be equipped with the following:

8.3.1 *Dispersive Element*—A device that separates the incident radiant flux into narrow bands of wavelength. It shall consist of a monochromator or a series of narrow-band interference filters. The stray light shall be sufficiently small to permit an accuracy of ± 0.005 in the measured values of x and y . The wavelength reproducibility shall be ± 1 nm or better.

8.3.2 *Receptor Stability and Linearity*—The receptor shall be stable and linear to within ± 1 % over the range to be measured.

8.3.3 *Output*—The spectroradiometer shall be capable of providing either graphical or digital information from which chromaticity coordinates can be computed.

8.3.4 *Collection Optics*—The radiant flux shall be collected by either limiting the acceptance cone to narrow angles or by such optical means as are used in a telecolorimeter.

8.4 *Light Projector Source*—The light source shall be a lamp with appropriate reflector and lenses to provide normal illumination on the test sample with a continuous spectral energy distribution having adequate power over the range 380 nm to 780 nm.

8.5 *Goniometer Sample Holder and Other Supports*—Suitable supports shall be provided for the source, telecolorimeter, and test samples as required so that the

geometric arrangement required for calibration and measurements can be achieved and maintained.

8.6 *Photometric Range*—The background behind the sample shall be flat black to minimize the effect of stray light. Light baffles shall be located, as necessary, between the projector and the test sample. Goniometer parts, range wall, ceiling, and floor exposed to the light beam shall be painted flat black.

9. Test Specimen and Sample

9.1 The test specimen is the unit on which the test is made. The specimen is the material selected by a sampling process which is not part of this practice.

9.2 The test specimen should be one entire retroreflector (a large retroreflector may be tested by summing the effects of smaller segments).

9.3 When testing retroreflective sheeting, a minimum area of $0.1 (\pm 0.05) \text{ m}^2$ should be used. This may be accomplished by testing a single specimen of this area or by averaging measurements of several smaller areas totaling $0.1 (\pm 0.05) \text{ m}^2$.

9.4 When testing retroreflective sheeting, the test specimen must be held flat by vacuum or some other means. It may be applied to a flat aluminum backing panel so that the entrance angle is consistent across the test specimen. Aluminum panels flat to ± 0.015 in. have been found satisfactory for this purpose.

10. Calibration and Standardization

10.1 *Light Source*—The projector light source used in Procedure B must be calibrated to a correlated color temperature of 2856 K. This may be accomplished by comparing the tristimulus values of the projector source to those of a reference lamp calibrated by a recognized agency or by measurement of the spectral power distribution of the projector source.

10.2 *Telecolorimeter*—The telecolorimeter must be calibrated before each measurement or series of measurements by using the method outlined in Procedure A.

10.3 *Telespectroradiometer*—The telespectroradiometer must be calibrated for wave-length accuracy and photometric scale linearity. An effective means to test the calibration of the unit is to measure the reference light level from the BaSO_4 standard and then to insert into the optical system colored filters of known chromaticity and then, by transmittance, measure the chromaticity of the standard filters. Filters specifically designed to test the accuracy of spectrophotometer systems are available and should be used for this purpose.

10.4 *Goniometer:*

10.4.1 Calibrate the goniometer at the 0° entrance angle position in the vertical and horizontal planes of the test sample. Take all measurements relative to this point and check each time the goniometer or light projector is moved. If measurements are to be made at extreme angles of 75° to near 90° , it is recommended to calibrate the goniometer at the 90° entrance angle position for greatest accuracy.

10.4.2 Accomplish calibration by locating a 300-mm (12-in.) square, high-quality, plane mirror in place of the sample. A 300-mm cross, centered on the surface of the mirror, can be

made with photographic black tape. A 600-mm square piece of white construction paper, with a hole in the center, can be placed over the exit aperture of the projector. By observing the white paper, the goniometer can be adjusted so that the shadow of the cross is reflected directly on the exit aperture of the projector. This horizontal position of the goniometer is the 0° entrance angle of the test sample.

11. Procedure

11.1 *General*—The geometry used to determine the performance of retroreflective materials shall be in accordance with Practice E808, for both Procedures A and B.

11.2 Procedure A—Telecolorimeter Method:

11.2.1 *Effective Responses*—The instrument makes N reading R_1, R_2, \dots, R_N each using a different filter ($N \geq 3$). The spectral designs of the filters, the detector (or detectors), and the light source are such that some linear combination of these N readings yields the CIE \bar{x} response to the specimen when illuminated by CIE Illuminant A, another linear combination of these readings yields the CIE \bar{y} response to the specimen when illuminated by CIE Illuminant A, and another linear combination of these readings yields the CIE \bar{z} response to the specimen when illuminated by CIE Illuminant A. For example, the three effective responses, $R_X, R_Y,$ and $R_Z,$ of a three-filter instrument are given by the following three equations based on nine coefficients.

$$\begin{aligned} R_X &= a_1R_1 + a_2R_2 + a_3R_3 \\ R_Y &= b_1R_1 + b_2R_2 + b_3R_3 \\ R_Z &= c_1R_1 + c_2R_2 + c_3R_3 \end{aligned}$$

The three effective responses of a four-filter instrument are given by the following three equations based on twelve coefficients.

$$\begin{aligned} R_X &= a_1R_1 + a_2R_2 + a_3R_3 + a_4R_4 \\ R_Y &= b_1R_1 + b_2R_2 + b_3R_3 + b_4R_4 \\ R_Z &= c_1R_1 + c_2R_2 + c_3R_3 + c_4R_4 \end{aligned}$$

For instruments based on five or more filters the three equations will be written analogously to these examples. All the coefficient values should be provided to the instrument user by the instrument maker.

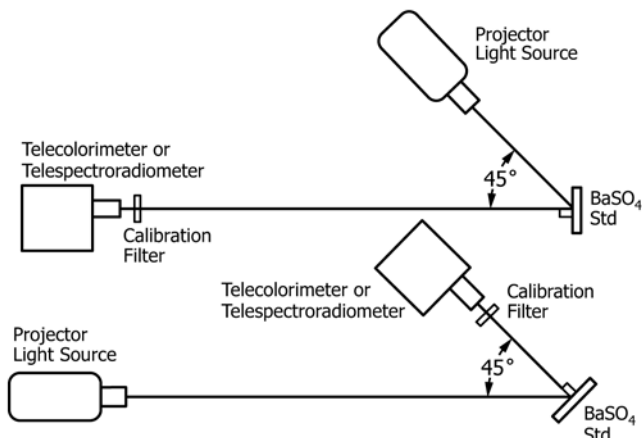

FIG. 1 Two Arrangements Suitable for Calibration of Telecolorimeter or Telespectroradiometer

NOTE 1—For the four-filter instrument described in E811 - 95 the coefficients have the following simple values:

$$\begin{aligned} a_1 &= 1 \\ a_2 &= 1 \\ a_3 &= 0 \\ a_4 &= 0 \\ b_1 &= 0 \\ b_2 &= 0 \\ b_3 &= 1 \\ b_4 &= 0 \\ c_1 &= 0 \\ c_2 &= 0 \\ c_3 &= 0 \\ c_4 &= 1 \end{aligned}$$

11.2.2 *Calibration of the Telecolorimeter*—Place a spectrally flat (white) diffusing surface in the sample position as shown in Fig. 1. Focus the telecolorimeter, equipped with the field aperture to be used during the color measurements, on the white surface. Obtain N readings R_1, R_2, \dots, R_N with the telecolorimeter for the N instrument filters and calculate the three corresponding effective responses $R_X, R_Y,$ and R_Z according to the equations in 11.2.1. The three responses should be found to be approximately in the ratio

$$1:0.910:0.324$$

Next insert into the auxiliary filter holder the reference filter of color similar to the specimen's, which has been measured with a spectrophotometer to have tristimulus values $X_{ref}, Y_{ref},$ and Z_{ref} for Illuminant A. Obtain N new readings $R_{1,ref}, R_{2,ref}, \dots, R_{N,ref}$ with the telecolorimeter for the N instrument filters and calculate the three corresponding effective responses $R_{X,ref}, R_{Y,ref},$ and $R_{Z,ref},$ according to the equations in 11.2.1.

11.2.2.1 Calculate the color correction factors $CF_X, CF_Y,$ and CF_Z as follows:

$$\begin{aligned} CF_X &= X_{ref}/R_{X,ref} \\ CF_Y &= Y_{ref}/R_{Y,ref} \\ CF_Z &= Z_{ref}/R_{Z,ref} \end{aligned}$$

where:

CF_X, CF_Y, CF_Z = correction factors
 $X_{ref}, Y_{ref}, Z_{ref}$ = the X, Y and Z values assigned to the reference filter. These values are determined with a spectrophotometer for Illuminant A and the 1931 Standard Observer.

$R_{X,ref}, R_{Y,ref}, R_{Z,ref}$ = telecolorimeter effective responses with the reference filter inserted calculated according to the equations in 11.2.1

11.2.3 *Color Measurement*—Reposition the telecolorimeter to achieve the geometric arrangement specified for the test material. No changes in the adjustment of the telecolorimeter shall be made, but the range scale of the instrument may be used. The same light source must be used for both calibration and color measurements. Focus the telecolorimeter on the test surface and ensure that the field stop aperture of the telecolorimeter is completely filled with light. Obtain N readings R_1, R_2, \dots, R_N from the specimen by positioning each of the N instrument filters in turn before the photoreceptor. Calculate

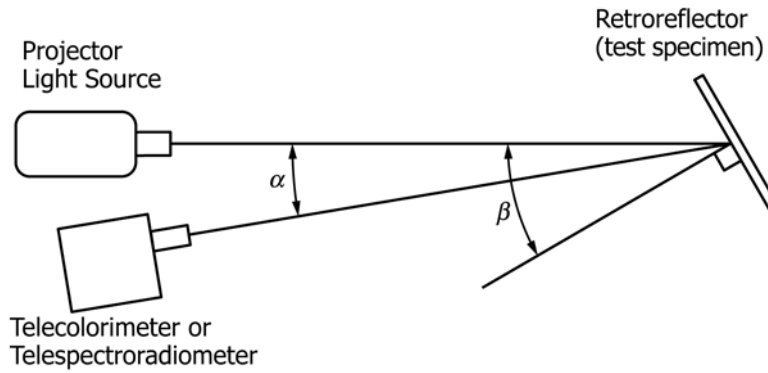

FIG. 2 Simplified Geometric Arrangement of Apparatus for Measurement of Chromaticity of Test Specimen

the three effective responses R_X , R_Y , and R_Z according to the equations in 11.2.1. Then correct these values by the following equations:

$$\begin{aligned} X_{test} &= R_X \cdot CF_X \\ Y_{test} &= R_Y \cdot CF_Y \\ Z_{test} &= R_Z \cdot CF_Z \end{aligned}$$

11.2.3.1 Compute the chromaticity coordinates (x, y) of the test specimen by the following equations:

$$\begin{aligned} x_{test} &= \frac{X_{test}}{X_{test} + Y_{test} + Z_{test}} \\ y_{test} &= \frac{Y_{test}}{X_{test} + Y_{test} + Z_{test}} \end{aligned}$$

11.3 Procedure B—Telespectroradiometer Method:

11.3.1 Use of Spectroradiometer—This method employs a spectroradiometer to measure the spectral distribution of the irradiance on the specimen and the irradiance at the receptor. Use of this method does not require that the source be at the proper color temperature or that the intensity scale of the spectroradiometer be properly calibrated. However, the spectroradiometer must be linear, and its wavelength scale must be calibrated. The collection optics of the spectroradiometer must be adjusted so that, when placed in the receptor position, either the entire retroreflecting specimen is contained within its field of view or the entire field of view is contained within the uniform specimen surface. In the case of retroreflecting devices, the first of these conditions is recommended. When the entire specimen is included in the field of view, the field of view should be sufficiently larger than the specimen to avoid problems in alignment, but not so large as to cause difficulty by collecting stray radiation. When the entire field of view is within the retroreflection specimen area, its size should be sufficiently smaller than the specimen area in order to avoid problems with misalignment, but should not be so small as to cause difficulty with specimen nonuniformity.

11.3.2 Color Measurement:

11.3.2.1 Place the spectroradiometer in the specimen position, ensuring that the entire source exit aperture is contained within the field of view of the spectroradiometer, and take readings $m_2(\lambda)$ at each wavelength from 380 to 780 nm at 10-nm intervals. Then return the spectroradiometer to the receptor position and take readings $m_1(\lambda)$ of the light reflected from the retroreflector being measured at each wavelength from 380 to 780 nm at 10-nm intervals.

11.3.2.2 An alternative set of $m_2(\lambda)$ readings can be obtained by viewing the radiation reflected from a BaSO₄ plaque as shown in Fig. 1. This method has the advantage that $m_1(\lambda)$ and $m_2(\lambda)$ can be made to be approximately the same magnitude by properly choosing the distance between the receptor and the white standard. However, in both methods, the position of the spectroradiometer must be held constant during the entire series of measurements of $m_2(\lambda)$ and its collection optics must not be changed from that used when $m_1(\lambda)$ is measured.

11.3.2.3 Calculate the tristimulus values $X, Y,$ and Z by the following equations:

$$\begin{aligned} X &= k \sum_{380}^{780} [m_1(\lambda)/m_2(\lambda)] S_A(\lambda) \bar{x}(\lambda) \Delta\lambda \\ Y &= k \sum_{380}^{780} [m_1(\lambda)/m_2(\lambda)] S_A(\lambda) \bar{y}(\lambda) \Delta\lambda \\ Z &= k \sum_{380}^{780} [m_1(\lambda)/m_2(\lambda)] S_A(\lambda) \bar{z}(\lambda) \Delta\lambda \end{aligned}$$

where:

- m_1 = reading of the sample
- m_2 = reading of the incident radiation, either directly or reflected from a BaSO₄ plaque

11.3.2.4 The chromaticity coordinates x and y are given by:

$$\begin{aligned} x &= X/(X + Y + Z) \\ y &= Y/(X + Y + Z) \end{aligned}$$

12. Precision and Bias

12.1 The precision and bias information contained in this section is based on the work of the International Commission on Illumination (CIE) and technical committee TC 2-19. The measurements were made on various grades and colors of retroreflective sheeting materials using spectral radiometers. The data is based on measurements at an entrance angle of 5 degrees of arc and an observation angle of 0.33 degrees of arc. The aperture size for both source and receptor is 10 minutes of arc. Table 1 shows the mean values of the chromaticity coordinates $x, y,$ from measurements on the test specimens made in the 6 laboratories that participated in the international intercomparison. Included for reference in this table is the mean value of the retroreflectance, R_A , of the test specimen calculated from the spectral measurements as described in CIE Technical Report 54.2.

**TABLE 1 Mean of Normalized Data — Retroreflectance [RA] and Chromaticity x, y values**

TC 2–19 Panel Designation		R _A	x	y
Enclosed Lens				
1	A(White)	96	0.4572	0.4305
2	B(Yellow)	48	0.5463	0.4451
3	C(Red)	25	0.6564	0.3421
4	D(Blue)	6	0.1094	0.2826
5	E(Green)	10	0.1852	0.5937
6	F(Brown)	5	0.5972	0.3904
7	G(Orange)	30	0.6165	0.3712
Encapsulated Lens				
8	H(White)	233	0.4589	0.4289
9	J(Yellow)	161	0.5549	0.4415
10	K(Red)	49	0.6769	0.3202
11	L(Blue)	23	0.1596	0.3161
12	M(Green)	43	0.1689	0.6020
13	N(Brown)	10	0.6136	0.3795
14	P(Orange)	92	0.5977	0.3940
Prismatic Materials				
15	R(White)	783	0.4500	0.4065
16	S(Yellow)	648	0.5478	0.4478
17	T(Red)	172	0.6792	0.3186
18	U(Blue)	53	0.1386	0.2509
19	V(Green)	70	0.1751	0.6857
20	W(Orange)	385	0.6161	0.3828

TABLE 3 95 % Repeatability Interval (Repeat Measurements Within a Single Laboratory)

TC 2–19 Panel Designation		x	y
Enclosed Lens			
1	A(White)	0.0015	0.0007
2	B(Yellow)	0.0008	0.0008
3	C(Red)	0.0010	0.0004
4	D(Blue)	0.0021	0.0042
5	E(Green)	0.0012	0.0046
6	F(Brown)	0.0070	0.0019
7	G(Orange)	0.0011	0.0004
Encapsulated Lens			
8	H(White)	0.0024	0.0004
9	J(Yellow)	0.0009	0.0009
10	K(Red)	0.0007	0.0004
11	L(Blue)	0.0018	0.0028
12	M(Green)	0.0011	0.0030
13	N(Brown)	0.0019	0.0006
14	P(Orange)	0.0008	0.0005
Prismatic Materials			
15	R(White)	0.0015	0.0006
16	S(Yellow)	0.0005	0.0005
17	T(Red)	0.0006	0.0003
18	U(Blue)	0.0005	0.0017
19	V(Green)	0.0012	0.0012
20	W(Orange)	0.0006	0.0007

TABLE 2 The Pooled Standard Deviation From the Mean of Chromaticity Measurements From Each of the 6 Laboratories

TC 2–19 Panel Designation		x	y
Enclosed Lens			
1	A(White)	0.0005	0.0003
2	B(Yellow)	0.0003	0.0003
3	C(Red)	0.0003	0.0001
4	D(Blue)	0.0007	0.0015
5	E(Green)	0.0004	0.0016
6	F(Brown)	0.0025	0.0007
7	G(Orange)	0.0004	0.0002
Encapsulated Lens			
8	H(White)	0.0009	0.0001
9	J(Yellow)	0.0003	0.0003
10	K(Red)	0.0003	0.0001
11	L(Blue)	0.0007	0.0010
12	M(Green)	0.0004	0.0011
13	N(Brown)	0.0007	0.0002
14	P(Orange)	0.0003	0.0002
Prismatic Material			
15	R(White)	0.0005	0.0002
16	S(Yellow)	0.0002	0.0002
17	T(Red)	0.0002	0.0001
18	U(Blue)	0.0002	0.0006
19	V(Green)	0.0004	0.0004
20	W(Orange)	0.0002	0.0002

TABLE 4 95 % Reproducibility Interval (Between Laboratories)

TC 2–19 Panel Designation		x	y
Enclosed Lens			
1	A(White)	0.0045	0.0026
2	B(Yellow)	0.0040	0.0022
3	C(Red)	0.0054	0.0031
4	D(Blue)	0.0099	0.0114
5	E(Green)	0.0109	0.0139
6	F(Brown)	0.0104	0.0030
7	G(Orange)	0.0063	0.0029
Encapsulated Lens			
8	H(White)	0.0049	0.0013
9	J(Yellow)	0.0037	0.0028
10	K(Red)	0.0050	0.0032
11	L(Blue)	0.0064	0.0116
12	M(Green)	0.0089	0.0098
13	N(Brown)	0.0069	0.0044
14	P(Orange)	0.0028	0.0033
Prismatic Materials			
15	R(White)	0.0067	0.0051
16	S(Yellow)	0.0082	0.0105
17	T(Red)	0.0042	0.0037
18	U(Blue)	0.0057	0.0160
19	V(Green)	0.0115	0.0132
20	W(Orange)	0.0039	0.0045

12.2 *Precision*—Table 2 shows the average precision of the nighttime chromaticity coordinates x, y, measurements expressed as the mean standard deviation from the mean of repeat measurements in the individual laboratories.

12.3 *Repeatability*—Table 3 shows the expected repeatability, at the 95 % confidence interval, within laboratories using the methods of Practice E691.

12.4 *Reproducibility*—Table 4 shows the expected reproducibility, at the 95 % confidence interval, between laboratories expressed using the methods of Practice E691. It is based on measurements in 6 laboratories.

13. Keywords

13.1 chromaticity; retroreflector

ASTM International takes no position respecting the validity of any patent rights asserted in connection with any item mentioned in this standard. Users of this standard are expressly advised that determination of the validity of any such patent rights, and the risk of infringement of such rights, are entirely their own responsibility.

This standard is subject to revision at any time by the responsible technical committee and must be reviewed every five years and if not revised, either reapproved or withdrawn. Your comments are invited either for revision of this standard or for additional standards and should be addressed to ASTM International Headquarters. Your comments will receive careful consideration at a meeting of the responsible technical committee, which you may attend. If you feel that your comments have not received a fair hearing you should make your views known to the ASTM Committee on Standards, at the address shown below.

This standard is copyrighted by ASTM International, 100 Barr Harbor Drive, PO Box C700, West Conshohocken, PA 19428-2959, United States. Individual reprints (single or multiple copies) of this standard may be obtained by contacting ASTM at the above address or at 610-832-9585 (phone), 610-832-9555 (fax), or service@astm.org (e-mail); or through the ASTM website (www.astm.org). Permission rights to photocopy the standard may also be secured from the Copyright Clearance Center, 222 Rosewood Drive, Danvers, MA 01923, Tel: (978) 646-2600; <http://www.copyright.com/>