



Designation: E81 – 96 (Reapproved 2017)

Standard Test Method for Preparing Quantitative Pole Figures¹

This standard is issued under the fixed designation E81; the number immediately following the designation indicates the year of original adoption or, in the case of revision, the year of last revision. A number in parentheses indicates the year of last reapproval. A superscript epsilon (ϵ) indicates an editorial change since the last revision or reapproval.

1. Scope

1.1 This test method covers the use of the X-ray diffractometer to prepare quantitative pole figures.

1.2 The test method consists of several experimental procedures. Some of the procedures (1-5)² permit preparation of a complete pole figure. Others must be used in combination to produce a complete pole figure.

1.3 Pole figures (6) and inverse pole figures (7-10) are two dimensional averages of the three-dimensional crystallite orientation distribution. Pole figures may be used to construct either inverse pole figures (11-13) or the crystallite orientation distribution (14-21). Development of series expansions of the crystallite orientation distribution from reflection pole figures (22, 23) makes it possible to obtain a series expansion of a complete pole figure from several incomplete pole figures. Pole figures or inverse pole figures derived by such methods shall be termed calculated. These techniques will not be described herein.

1.4 Provided the orientation is homogeneous through the thickness of the sheet, certain procedures (1-3) may be used to obtain a complete pole figure.

1.5 Provided the orientation has mirror symmetry with respect to planes perpendicular to the rolling, transverse, and normal directions, certain procedures (4, 5, 24) may be used to obtain a complete pole figure.

1.6 The test method emphasizes the Schulz reflection technique (25). Other techniques (3, 4, 5, 24) may be considered variants of the Schulz technique and are cited as options, but not described herein.

1.7 The test method also includes a description of the transmission technique of Decker, et al (26), which may be used in conjunction with the Schulz reflection technique to obtain a complete pole figure.

¹ This test method is under the jurisdiction of ASTM Committee E04 on Metallography and is the direct responsibility of Subcommittee E04.11 on X-Ray and Electron Metallography.

Current edition approved June 1, 2017. Published June 2017. Originally approved in 1949. Last previous edition approved in 2011 as E81 – 96 (2011). DOI: 10.1520/E0081-96R17.

² The boldface numbers in parentheses refer to the list of references at the end of this test method.

1.8 *This standard does not purport to address all of the safety concerns, if any, associated with its use. It is the responsibility of the user of this standard to establish appropriate safety and health practices and determine the applicability of regulatory limitations prior to use.*

1.9 *This international standard was developed in accordance with internationally recognized principles on standardization established in the Decision on Principles for the Development of International Standards, Guides and Recommendations issued by the World Trade Organization Technical Barriers to Trade (TBT) Committee.*

2. Summary of Test Method

2.1 The test method consists of characterizing the distribution of orientations of selected lattice planes with respect to sample-fixed coordinates (6). The distribution will usually be obtained by measurement of the intensity of X rays diffracted by the sample. In such measurements the detector and associated limiting slits are fixed at twice the appropriate Bragg angle, and the diffracted intensity is recorded as the orientation of the sample is changed (1-6, 25, 26, 27). After the measured data have been corrected, as necessary, for background, defocusing, and absorption, and normalized to have an average value of unity, the results may be plotted in stereographic or equal-area projection.

2.2 The geometry of the Schulz (25) reflection method is illustrated in Fig. 1. Goniometers employing this geometry are commercially available. The source of X rays is indicated by L . Slit S1 limits divergence of the incident beam in the plane of projection. Slit S2 limits divergence perpendicular to the plane of projection. The sample, indicated by crosshatching, may be tilted about the axis FF' , which is perpendicular to the diffractometer axis and lies in the plane of the sample. The tilt angle was denoted ϕ by Schulz (25). The sample position shown in Fig. 1 corresponds to $\phi = 0$ deg, for which approximate parafoocusing conditions exist at the detector slit, S3. With the application of a defocusing correction, this method is useful over a range of colatitude ϕ from 0 deg to approximately 75 deg.

2.2.1 Tilting the sample about FF' , so as to reduce the distance between L and points in the sample surface above the plane of projection, causes X rays diffracted from these points to be displaced to the left of the center of S3, while X rays diffracted from points in the sample surface below the plane of

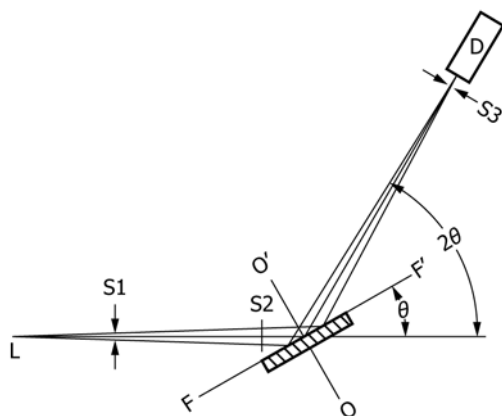

FIG. 1 Geometry of Reflection Method.

projection are displaced to the right of the center of S3. The displacement is equal to $2D \tan \phi \cos \theta$, where D is the distance above or below the plane of projection. The integrated, or total, diffracted intensity is influenced only slightly by tilting the sample (28). Insofar as possible, the detector slit shall be of sufficient width to include the defocused line profile corresponding to the maximum sample tilt for which measurements are to be made. Because of interferences from neighboring diffraction peaks and physical limitations on sample size and detector slit width, it is necessary to limit vertical divergence of the incident beam. A widely used pole figure goniometer with a focal spot to the center of the sample distance of 172 mm employs a 0.5-mm slit located 30 mm from the center of the sample for this purpose. Measured intensities may be corrected for defocusing by comparison with intensities diffracted by a randomly oriented specimen of similar material, or by employing the theoretically calculated corrections (28).

2.3 The geometry of the transmission technique of Decker, et al (26) is shown in Fig. 2. In contrast to the reflection method, X rays diffracted from different points in the sample diverge, making the resolution of adjacent peaks more difficult. The ratio of the diffracted intensity at $\alpha = -5, -10, \dots, -70$ deg, to the diffracted intensity at $\alpha = 0$ deg, calculated in accordance with the expression given by Decker, et al (26) for linear absorption thickness product, $\mu t = 1.0, 1.4, \dots, 3.0$, and, for $\theta = 5, 10, \dots, 25$ deg is given in Table 1. These data may be used as a guide to determine the useful range of α for a given

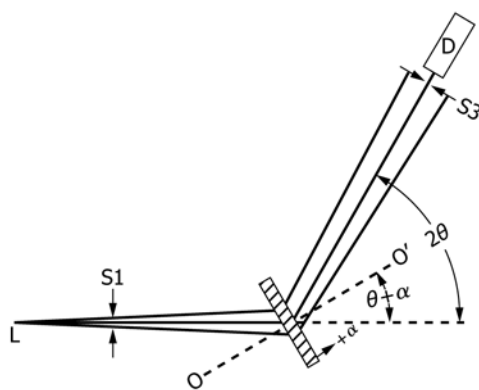

FIG. 2 Geometry of Transmission Method.

μt and θ . If, for example, I_α / I_0 is restricted to values ≥ 0.5 , one arrives at the series of curves shown in Fig. 3.

3. Significance and Use

3.1 Pole figures are two-dimensional graphic representations, on polar coordinate paper, of the average distribution of crystallite orientations in three dimensions. Data for constructing pole figures are obtained with X-ray diffractometers, using reflection and transmission techniques.

3.2 Several alternative procedures may be used. Some produce complete pole figures. Others yield partial pole figures, which may be combined to produce a complete figure.

4. Apparatus

4.1 *Source of X Rays*—A beam of characteristic X rays of substantially constant intensity is required. Characteristic K-alpha radiation of chromium, iron, cobalt, nickel, copper, molybdenum, and silver have all been used successfully, depending on the chemical composition of the specimen. Insofar as possible, the radiation selected shall provide sufficient angular dispersion to permit the resolution of peaks to be measured, and shall not produce excessive fluorescence in the sample. Linear absorption coefficients (29) for selected elements are given in Table 2. Lower energy radiation (Cr, Fe, Co, Ni, Cu) is generally preferred for reflection pole figure measurements as it provides greater angular dispersion. Higher energy radiation (Mo, Ag) is generally preferred for transmission measurements.

4.2 *Slits*—Suitable slits shall be provided to limit horizontal (in the plane of projection of Figs. 1 and 2) and vertical (perpendicular to the plane of projection of Figs. 1 and 2) divergence of the incident beam. Horizontal divergences of 1 to 3 deg for reflection and 0.5 deg for transmission are typical. Vertical divergences of 0.2 deg for reflection and 1 deg for transmission are typical. Insofar as possible, the receiving slit shall be of sufficient width to include the diffracted peak. Receiving slits corresponding to 1 deg 2-theta are typical.

4.3 *Specimen Holder—Reflection Method:*

4.3.1 The specimen holder for the reflection method shall preferably employ the Schulz reflection geometry illustrated in Fig. 1 and described in 2.2. It is desirable that the specimen holder be equipped with a means for oscillating the sample in the plane of its surface without changing the orientation of the sample. It is also desirable that the magnitude of the oscillation be variable. The specimen holder shall preferably be provided with automatic means for changing colatitude and longitude of the sample.

4.3.2 Alternative reflection geometries include those of Bakarian (1), Field and Marchant (27), and Jetter and Borie (2). The method of Bakarian requires machining a number of cylindrical specimens whose axes are perpendicular to the sheet normal direction. Each specimen provides intensity data along one parallel of longitude. The method of Jetter and Borie entails the preparation of a spherical specimen. In the methods of Bakarian and of Jetter and Borie, the sample shall, insofar as possible, be prepared from homogeneous material. These methods have the advantage that intensity data need not be corrected for absorption or defocusing. They do not permit

TABLE 1 (I_a/I_0) × 1000

θ	μt	$-\alpha$													
		5	10	15	20	25	30	35	40	45	50	55	60	65	70
5	1.0	992	984	976	966	954	939	918	890	851	796	703	617	480	313
	1.4	991	978	962	941	915	882	840	786	719	636	533	412	277	146
	1.8	989	972	948	917	878	828	768	695	608	508	395	276	162	070
	2.2	988	966	935	893	842	778	702	614	515	406	294	186	095	034
	2.6	986	960	922	871	807	731	643	544	436	326	219	126	057	017
	3.0	985	954	909	849	775	687	589	481	370	261	164	086	034	009
10	1.0	984	969	952	934	912	887	855	815	762	694	603	486	344	191
	1.4	983	962	938	908	873	831	779	716	640	548	440	320	198	094
	1.8	981	956	924	884	836	779	710	630	538	435	325	215	119	049
	2.2	980	950	911	861	801	730	649	556	455	348	242	147	074	027
	2.6	978	944	898	839	768	686	593	492	385	280	183	103	047	016
	3.0	977	938	885	817	737	644	543	436	328	226	139	073	030	009
15	1.0	976	952	927	900	868	832	789	735	668	583	477	349	209	085
	1.4	975	946	912	874	829	776	714	640	553	453	342	227	123	046
	1.8	973	939	898	850	792	725	648	560	462	358	252	155	078	027
	2.2	972	933	885	826	758	678	590	492	389	286	190	110	052	017
	2.6	970	927	872	804	725	636	538	435	331	232	146	080	036	011
	3.0	968	921	859	783	695	597	493	386	283	190	115	060	025	007
20	1.0	968	935	901	863	822	774	718	649	566	465	345	214	093	000
	1.4	966	928	885	836	781	717	643	557	460	354	243	140	058	000
	1.8	964	921	870	811	743	666	579	484	381	278	180	099	039	000
	2.2	963	915	857	788	709	621	525	424	321	224	139	074	028	000
	2.6	961	909	843	766	678	582	479	375	274	185	111	057	020	000
	3.0	960	903	831	746	650	547	440	335	238	155	090	044	015	000
25	1.0	959	917	872	824	771	710	639	555	455	339	214	096	000	
	1.4	957	909	856	796	728	651	565	468	362	253	151	065	000	
	1.8	955	902	840	770	690	602	505	402	298	200	115	048	000	
	2.2	953	895	826	746	657	560	456	352	253	164	092	038	000	
	2.6	952	889	812	724	627	523	417	314	219	139	076	031	000	
	3.0	950	883	800	705	601	493	384	283	194	121	065	025	000	

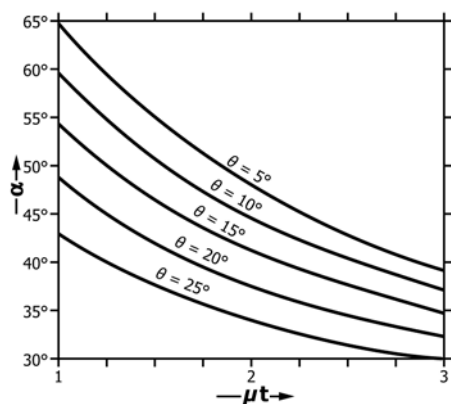

FIG. 3 α versus μt for $I_a/I_0 = 0.5$, $\theta = 5, 10, \dots, 25$ deg.

oscillation of the sample. Equipment is not currently commercially available for these methods.

4.3.3 The method of Field and Marchant (27) requires an absorption correction. If this method is used in conjunction with the transmission method of Decker, et al (26), it is necessary to use either different orders of reflection or different radiations in order to obtain a complete pole figure.

4.4 Specimen Holder—Transmission Method—If the transmission method is used, the specimen holder shall employ the geometry of Decker, et al (26), shown in Fig. 2 and described in 2.3. It is desirable that the specimen holder be equipped with a means for oscillating the sample in the plane of its surface without changing the orientation of the sample. The specimen holder shall preferably be provided with automatic means for changing colatitude and longitude of the sample.

4.5 Detector—The detector shall preferably be of an energy-dispersive type, for example, a solid state, proportional, or scintillation counter, and used in conjunction with a pulse height selector circuit to discriminate against X rays whose energies differ markedly from that of the characteristic K-alpha radiation being used. Reduction of the characteristic K-beta radiation requires the use of a monochromator or appropriate beta filter. Pd, Zr, Ni, Co, Fe, Mn, and V are appropriate beta filters for Ag, Mo, Cu, Ni, Co, Fe, and Cr, respectively.

5. Test Specimens

5.1 For the reflection method, the sample shall be of sufficient thickness that loss of intensity due to transmission through the sample may be ignored. If a maximum loss of 1 % the incident beam is acceptable, the specimen must have a linear absorption thickness product equal to or greater than $2.3 \sin \theta$. For an iron sample with molybdenum K-alpha radiation, this requires that μt be greater than 0.4, 0.6, and 0.7 for the (110), (200), and (211) reflections, respectively.

5.1.1 Surface preparation is particularly important in the reflection method. Calculations due to Borie (30), who assumed a sawtooth surface of spacing a on a material with linear absorption coefficient μ , indicate that the product μa should be less than 0.5 if significant intensity losses are to be avoided. For an iron sample with cobalt K-alpha radiation, $\mu = 416 \text{ cm}^{-1}$, corresponding to $a \leq 12 \text{ }\mu\text{m}$.

5.2 For the transmission method, maximum intensity is obtained for a linear absorption thickness product equal to $\cos \theta$. For an iron sample with molybdenum K-alpha, this corresponds to μt equal to 0.98, 0.97, and 0.95 for the (110), (200),

TABLE 2 Linear Absorption Coefficient μ (cm^{-1}) for Selected Wavelengths and Elements

		K-alpha Radiation						
		Ag	Mo	Cu	Ni	Co	Fe	Cr
λ		0.5608	0.7107	1.5418	1.6591	1.7902	1.9373	2.2909
Absorber								
6	C	0.90	1.41	10.4	12.8	15.9	20.0	32.6
12	Mg	3.69	7.15	67.2	83.0	104	130	211
13	Al	7.15	13.9	131	162	202	253	410
22	Ti	55.4	109	936	1134	1386	1696	2570
24	Cr	114	224	1869	2258	2739	3329	574
25	Mn	131	257	2115	2545	3072	424	539
26	Fe	155	303	2424	2912	416	523	850
27	Co	194	378	2786	436	544	684	1112
28	Ni	214	415	407	503	627	789	1282
29	Cu	236	455	472	585	729	920	1482
30	Zn	205	395	430	532	663	834	1348
40	Zr	380	103	930	1144	1404	1742	2724
42	Mo	661	188	1652	2020	2479	3060	4723
47	Ag	137	271	2287	2769	3367	4102	6147
48	Cd	121	238	1998	2413	2924	3564	5302
50	Sn	116	227	1869	2256	2723	3292	4833
74	W	1023	1912	3320	4014	4883	5944	8839
79	Au	1215	2215	4006	4815	5817	7030	10250
82	Pb	768	1361	2631	3153	3788	4559	6566

and (211) reflections, respectively. Thus, a suitable transmission sample can also be used for reflection measurements.

5.3 Ordinarily test specimens are obtained from thicker sections by reducing them mechanically so far as possible and then etching to final thickness. The sample must not be overheated or plastically deformed during the thinning process. The etchant used must remove material uniformly without pitting. The finished specimen may have a “matte” appearance, but surfaces shall be flat and parallel.

5.3.1 For an iron sample with molybdenum K-alpha radiation, the linear absorption coefficient is 303 cm^{-1} , and optimum specimen thickness for transmission is approximately 0.03 mm (0.001 in.). It is extremely difficult to prepare specimens this thin, and in practice iron specimens 0.05 to 0.1 mm (0.002 to 0.004 in.) are normally used in transmission with molybdenum K-alpha radiation.

5.4 A statistical deviation of 5% requires diffraction from 400 grains. For diffraction from planes of multiplicity factor 6 and a receiving slit typically subtending a solid angle on the order of $1/(2 \times 10^4)$ of 4π , the surface examined must contain $400 \times 2 \times 10^4 / 6$, that is, on the order of 10^6 grains. If 1 cm^2 of surface is examined, the grain size should ideally be ASTM 10 or finer.

6. Procedure

6.1 Select an X-ray tube appropriate to the sample, diffracting planes, and experimental method (reflection, transmission, or both). See 4.1 and Table 2. If it is desired to obtain a complete pole figure by combination of reflection and transmission measurements, the same target (usually molybdenum) shall preferably be used in both measurements.

6.2 Set the detector, amplifier, and pulse height selector in accordance with the manufacturer’s recommendations.

6.3 Measure diffracted intensity at constant X-ray tube potential as the tube current is increased. Intensity should increase linearly with the X-ray tube current. Departure from

linearity at high counting rates (typically several thousand counts per second) is due to coincidence losses in the detector or resolving time of the amplifier and pulse-height selector circuits. The X-ray tube current must be adjusted to keep below counting rates at which departure from linearity becomes significant.

6.4 In the event that the transmission method is to be used, measure the linear absorption thickness product, μt , of the specimen. This is best accomplished by placing a similar material in the specimen holder, measuring the intensity of the diffracted beam, I_1 , placing the specimen between the divergence slit and the specimen holder so that the specimen surface is perpendicular to the incident beam, and measuring the intensity of the diffracted beam, I_2 . The linear absorption thickness product, μt , is given by $-\ln(I_2/I_1)$.

6.4.1 If diffraction data from a random sample are used to correct for defocusing, select a random sample having a linear absorption thickness product, μt , equal to that of the specimen being measured. This is normally accomplished by combining several layers of random sample until the diffracted intensity with the random compact inserted between the divergence slit and the specimen holder is equal to that for the specimen inserted in the same position.

6.5 If both transmission and reflection measurements are to be made on the same sample, it is preferable to make transmission measurements first, because of the greater danger of damaging the sample during removal from the reflection specimen holder.

6.5.1 Interpolation, using the data in Table 1, and the linear absorption thickness product, μt , of the specimen and Bragg angle, θ , for the (hkl) reflection and characteristic X-radiation selected, may be used to construct a plot of (I_α/I_0) versus $-\alpha$. Alternatively, such curves may be calculated in accordance with Decker, et al (26), or experimentally determined using a random sample with the same linear absorption thickness product as that of the specimen.

6.5.2 A similar curve (I_ϕ / I_0) versus ϕ may be constructed for the reflection case, either by calculation (28) or experimentally determined using a random sample. If the curves (I_α / I_0) versus $-\alpha$ and (I_ϕ / I_0) versus ϕ are experimentally determined, it is desirable to make measurements of background intensities on either side of the diffraction peak. Background intensity under the peak may be taken as the average of background on either side of the peak. If background intensity is significant by comparison with peak intensity, subtract the background intensity from the peak intensity before constructing plots of (I_ϕ / I_0) versus ϕ and (I_α / I_0) versus $-\alpha$.

6.5.3 The value of ϕ or $-\alpha$, where $\phi + (-\alpha) = 90$ deg, for which (I_ϕ / I_0) and (I_α / I_0) are equal, is selected as the boundary between regions of the pole figure measured by reflection and by transmission. Curves of I_ϕ / I_0 versus ϕ and I_α / I_0 versus $-\alpha$ for the (200) reflection of a α -brass sample ($\mu t = 2.36$) with molybdenum K-alpha radiation are shown in Fig. 4. The curve of I_α / I_0 versus $-\alpha$ was calculated in accordance with Decker, et al (26). The curve of I_ϕ / I_0 versus ϕ was determined experimentally, using a randomly oriented copper specimen. For this specimen, the region from $\phi = 0$ to 60 deg ($\alpha = -30$ to -90 deg) should be measured by the Schulz reflection method, while the region from $\alpha = 0$ to -30 deg ($\phi = 60$ to 90 deg) should be scanned by the transmission method.

6.6 Measure diffracted intensity in transmission as latitude and longitude coordinates are varied. Measure background on either side of the peak (if other peaks do not interfere) as a function of $-\alpha$. Subtract background from peak intensities.

6.7 If a random standard is used to correct for absorption, repeat 6.6 with the random standard in the specimen holder.

6.8 Measure diffracted intensity in reflection as colatitude and longitude coordinates are varied. Measure background on either side of the peak (if others peaks do not interfere) as a function of ϕ . Subtract background from peak intensities.

6.9 If a random standard is used to correct for defocusing, repeat 6.8 with the random standard in the specimen holder.

6.10 Correct transmission data for absorption and reflection data for defocusing.

6.11 Match or blend transmission and reflection regions. This may be done by scaling either all of the transmission or all of the reflection intensities so that the average of the transmission intensities along the boundary is equal to the average of the reflection intensities along the boundary after scaling. Individual intensities along the boundary shall preferably be assigned the mean value of the corresponding reflection and transmission intensities after scaling.

6.12 Data shall be normalized to have an average value of unity. In this averaging procedure, assign each data point a weight proportional to the solid angle which the point represents.

6.13 Normalized data may be plotted in stereographic or equal-area projection. It is customary to use the plane of the sheet as the plane of projection. The nature of the projection should be stated. A {200} pole figure of an α -brass sheet cold-rolled 90 % and recrystallized is shown in Fig. 5. The region $\phi = 0$ to 60 deg was determined by the Schulz reflection method. The region $\phi = 60$ to 90 deg was determined by the transmission method.

7. Random Intensities

7.1 Random intensities, if required, shall be established either through the use of random standard samples or by theoretical calculation (24, 26, 28). The use of random standard samples is preferred where suitable samples can be prepared.

7.1.1 For reflection methods, random standard samples may be prepared by hydrostatically compressing and sintering a powder of crystallite size determined in accordance with 5.4.

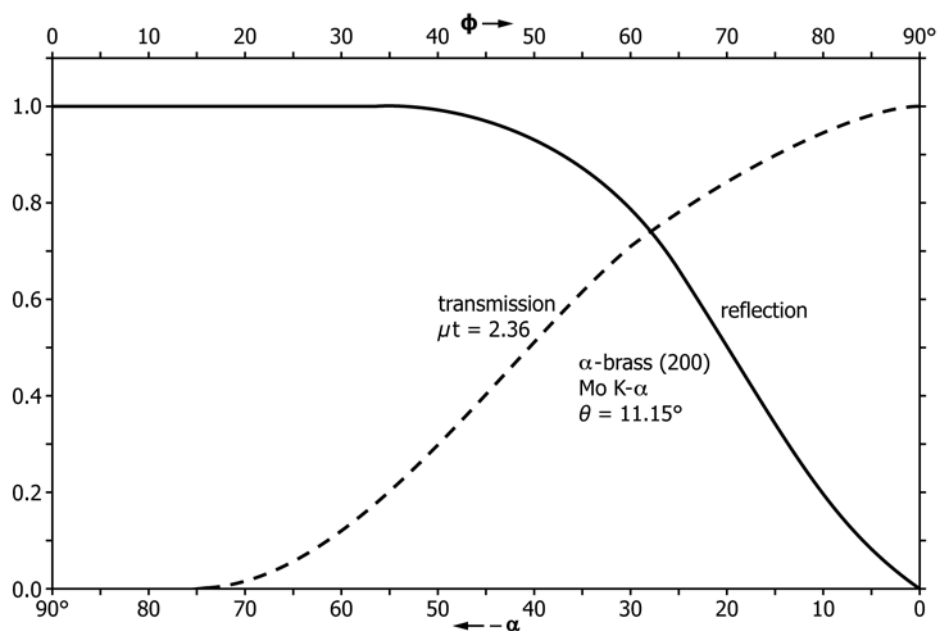

FIG. 4 I_ϕ / I_0 versus ϕ (solid) and I_α / I_0 versus $-\alpha$ (dashed).

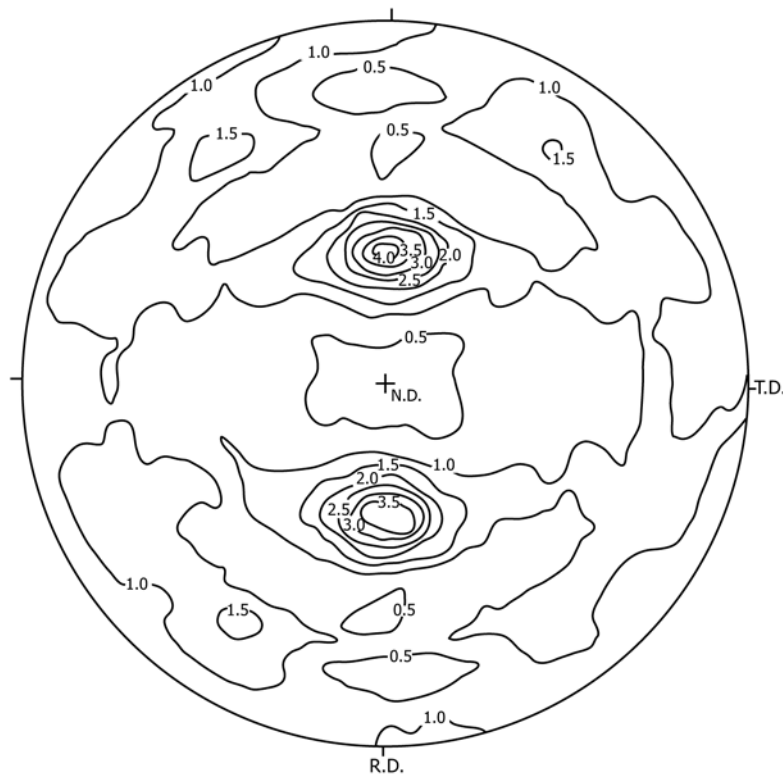

FIG. 5 α -Brass {200} Pole Figure Equal Area Projection.

The standard may be checked for random orientation by comparing diffraction patterns obtained from three perpendicular faces.

7.1.2 It is extremely difficult to prepare random standard samples for transmission having diffracting properties, background, and density similar to test specimens. Grains of appropriate diameter (see 5.4) may be added to clear Glyptal,³ and the mixture spray painted on weighing paper using a medical atomizer. Each application must be light enough so

that there is no dripping. The desired thickness may be obtained by a series of applications. If allowed to dry, the mixture may be peeled from the paper. Random standard samples prepared in this manner have densities much lower than solid specimens and yield higher backgrounds. The use of theoretical corrections (26) based on the measured linear absorption thickness product would seem to be preferred in the transmission case.

8. Keywords

8.1 crystal; orientation; pole figure; X-ray diffraction

³ Glyptal is a registered trademark of the General Electric Company.

REFERENCES

- (1) Bakarian, P. W., "Preferred Orientation in Rolled Magnesium and Magnesium Alloys," *Transactions of the American Institute of Mining and Metallurgical Engineers, Institute of Metals Division, TAMDA*, Vol 147, 1942, p. 266.
- (2) Jetter, L. K., and Borie, B. S., Jr., "A Method for the Quantitative Determination of Preferred Orientation," *Journal of Applied Physics, JAPIA*, Vol 24, 1953, p. 532.
- (3) Mueller, M. H., and Knott, H. W., "Quantitative Pole Figures for Sheet Material by the Reflection Technique," *Review of Scientific Instruments, RSINA*, Vol 25, 1954, p. 1115.
- (4) Lopata, S. L., and Kula, E. B., "A Reflection Method for Pole Figure Determination," *Transactions of the Metallurgical Society of A.I.M.E./ American Institute of Mining, Metallurgical, and Petroleum Engineers, TMSAA*, Vol 224, 1962, p. 865.
- (5) Mieran, E. S., "Use of the Reciprocal Lattice for the Development of a New Pole Figure Technique," *Review of Scientific Instruments, RSINA*, Vol 33, 1962, p. 319.
- (6) Wever, F., "Über die Walzstruktur kubisch kristallisierender Metalle," *Zeitschrift für Physik, ZEPYA*, Vol 28, 1924, p. 69.
- (7) Barrett, C. S., and Levenson, L. H., "The Structure of Aluminum After Compression," *Transactions of the American Institute of Mining and Metallurgical Engineers, Institute of Metals Division, TAMDA*, Vol 137, 1940, p. 112.
- (8) Harris, G. B., "Quantitative Measurement of Preferred Orientation in Rolled Uranium Bars," *Philosophical Magazine, PHMAA*, Vol 43, 1952, p. 113.
- (9) Morris, P. R., "An Internal Standard for the Determination of the Proportionality Constant in Preferred Orientation Studies," USAEC Report FMPC-310, 1953.
- (10) Morris, P. R., "Reducing the Effects of Nonuniform Pole Distribution in Inverse Pole Figures," *Journal of Applied Physics, JAPIA*, Vol 30, 1959, p. 595.

- (11) Jetter, L. K., McHargue, C. J., and Williams, R. O., “Method of Representing Preferred Orientation Data,” *Journal of Applied Physics*, JAPIA, Vol 27, 1956, p. 368.
- (12) Bunge, H. J., “Zur Darstellung von Fasertexturen,” *Deutsche Akademie der Wissenschaften Zu Berlin, Monatsberichte*, MDAWA, Vol 1, 1959, p. 27.
- (13) Roe, R.-J., and Krigbaum, W. R., “Description of Crystallite Orientation in Polycrystalline Materials Having Fiber Texture,” *Journal of Chemical Physics*, JCPA, Vol 40, 1964, p. 2608.
- (14) Viglin, A. S., “A Quantitative Measure of the Texture of a Polycrystalline Material-Texture Function,” *Fizika Tverdogo Tela*, FTVTA, Vol 2, 1960, p. 2463.
- (15) Bunge, H. J., “Zur Darstellung Allgemeiner Texturen,” *Zeitschrift fur Metallkunde*, ZEMIA, Vol 56, 1965, p. 872.
- (16) Roe, R.-J., “Description of Crystallite Orientation in Polycrystalline Materials. III General Solution to Pole Figure Inversion,” *Journal of Applied Physics*, JAPIA, Vol 36, 1965, p. 2024.
- (17) Roe, R.-J., “Inversion of Pole Figures for Materials Having Cubic Symmetry,” *Journal of Applied Physics*, JAPIA, Vol 37, 1966, p. 2069.
- (18) Williams, R. O., “The Representation of the Textures of Rolled Copper, Brass, and Aluminum by Biaxial Pole Figures,” *Transactions of the Metallurgical Society of A.I.M.E./American Institute of Mining, Metallurgical and Petroleum Engineers*, TMSAA, Vol 242, 1968, p. 105.
- (19) Bunge, H. J., “Mathematische Methoden der Texturanalyse,” Akademie-Verlag, Berlin, (1969).
- (20) Pospiech, J., and Jura, J., “Fourier Coefficients of the Generalized Spherical Function and an Exemplary Computer Program,” *Kristall und Technik*, KRTEA, Vol 10, 1975, p. 783.
- (21) Morris, P. R., “Program for Calculation of Augmented Jacobi Polynomials,” *Texture*, TEXUA, Vol 2, 1975, p. 57.
- (22) Pospiech, J., and Jura, J., “Determination of the Orientation Distribution Function from Incomplete Pole Figures,” *Zeitschrift fur Metallkunde*, ZEMIA, Vol 65, 1974, p. 324.
- (23) Morris, P. R., “Crystallite Orientation Analysis from Incomplete Pole Figures,” *Advances in X-Ray Analysis*, Vol 18, Pickels, W. L., Barrett, C. W., Newkirk, J. B., and Ruud, C. O., Editors, Plenum, New York, 1975.
- (24) Wilson, D., and Bainbridge, D. W., “Defocusing Correction for the Measurement of Preferred Orientation,” *Metallurgical Abstracts*, MEABA, Vol 2, 1971, p. 2925.
- (25) Schulz, L. G., “A Direct Method of Determining Preferred Orientation of a Flat Reflection Sample Using a Geiger Counter X-Ray Spectrometer,” *Journal of Applied Physics*, JAPIA, Vol 20, 1949, p. 1030.
- (26) Decker, B. F., Asp, E. T., and Harker, D., “Preferred Orientation Determination Using a Geiger Counter X-Ray Diffraction Goniometer,” *Journal of Applied Physics*, JAPIA, Vol 19, 1948, p. 388.
- (27) Field, M., and Marchant, M. E., “Reflection Method of Determining Preferred Orientation on the Geiger-Counter Spectrometer,” *Journal of Applied Physics*, JAPIA, Vol 20, 1949, p. 741.
- (28) Gale, B., and Griffiths, D., “Influence of Instrumental Aberrations on the Schulz Technique for the Measurement of Pole Figures,” *British Journal of Applied Physics*, BJAPA, Vol 11, 1960, p. 96.
- (29) MacGillavry, C. H., and Rieck, G. D., eds., “International Tables for X-Ray Crystallography, Vol III, 1962, pp. 46–56, 162–169.
- (30) Trucano, P., and Batterman, B. W., *Journal of Applied Physics*, JAPIA, Vol 41, 1970, p. 3949.

ASTM International takes no position respecting the validity of any patent rights asserted in connection with any item mentioned in this standard. Users of this standard are expressly advised that determination of the validity of any such patent rights, and the risk of infringement of such rights, are entirely their own responsibility.

This standard is subject to revision at any time by the responsible technical committee and must be reviewed every five years and if not revised, either reapproved or withdrawn. Your comments are invited either for revision of this standard or for additional standards and should be addressed to ASTM International Headquarters. Your comments will receive careful consideration at a meeting of the responsible technical committee, which you may attend. If you feel that your comments have not received a fair hearing you should make your views known to the ASTM Committee on Standards, at the address shown below.

This standard is copyrighted by ASTM International, 100 Barr Harbor Drive, PO Box C700, West Conshohocken, PA 19428-2959, United States. Individual reprints (single or multiple copies) of this standard may be obtained by contacting ASTM at the above address or at 610-832-9585 (phone), 610-832-9555 (fax), or service@astm.org (e-mail); or through the ASTM website (www.astm.org). Permission rights to photocopy the standard may also be secured from the Copyright Clearance Center, 222 Rosewood Drive, Danvers, MA 01923, Tel: (978) 646-2600; http://www.copyright.com/