



Standard Practice for Exposure of Cover Materials for Solar Collectors to Natural Weathering Under Conditions Simulating Operational Mode¹

This standard is issued under the fixed designation E782; the number immediately following the designation indicates the year of original adoption or, in the case of revision, the year of last revision. A number in parentheses indicates the year of last reapproval. A superscript epsilon (ϵ) indicates an editorial change since the last revision or reapproval.

1. Scope

1.1 This practice provides a procedure for the exposure of cover materials for flat-plate solar collectors to the natural weather environment at temperatures that are elevated to approximate operating conditions.

1.2 This practice is suitable for exposure of both glass and plastic solar collector cover materials. Provisions are made for exposure of single and double cover assemblies to accommodate the need for exposure of both inner and outer solar collector cover materials.

1.3 This practice does not apply to cover materials for evacuated collectors or photovoltaics.

1.4 The values stated in SI units are to be regarded as the standard.

1.5 *This standard does not purport to address all of the safety concerns, if any, associated with its use. It is the responsibility of the user of this standard to establish appropriate safety and health practices and determine the applicability of regulatory limitations prior to use.*

2. Referenced Documents

2.1 ASTM Standards:²

E781 Practice for Evaluating Absorptive Solar Receiver Materials When Exposed to Conditions Simulating Stagnation in Solar Collectors With Cover Plates

E881 Practice for Exposure of Solar Collector Cover Materials to Natural Weathering Under Conditions Simulating Stagnation Mode

G7 Practice for Atmospheric Environmental Exposure Testing of Nonmetallic Materials

¹ These test methods are under the jurisdiction of ASTM Committee E44 on Solar, Geothermal and Other Alternative Energy Sources and is the direct responsibility of Subcommittee E44.05 on Solar Heating and Cooling Systems and Materials.

Current edition approved March 1, 2015. Published April 2015. Originally approved in 1981. Last previous edition approved in 2007 as E782 – 95 (2007). DOI: 10.1520/E0782-95R15.

² For referenced ASTM standards, visit the ASTM website, www.astm.org, or contact ASTM Customer Service at service@astm.org. For *Annual Book of ASTM Standards* volume information, refer to the standard's Document Summary page on the ASTM website.

3. Significance and Use

3.1 This practice describes a weathering box test fixture and provides uniform exposure guidelines to minimize the variables encountered during outdoor exposure testing.

3.2 This practice may be useful in comparing the performance of different materials at one site or the performance of the same material at different sites, or both.

3.3 Since the combination of elevated temperature and solar radiation may cause some solar collector cover materials to degrade more rapidly than either alone, a weathering box that elevates the temperature of the cover materials is used.

3.4 This practice is intended to assist in the evaluation of solar collector cover materials in the operational, not stagnation mode. Insufficient data exist to obtain exact correlation between the behavior of materials exposed according to this practice and actual in-service performance.

3.5 Means of evaluation of effects of weathering are provided in Practice E781, and in other ASTM test methods that evaluate material properties.

3.6 Tests of the type described in this practice may be used to evaluate the stability of solar collector cover materials when exposed outdoors to the varied influences which comprise weather. Exposure conditions are complex and changeable. Important factors are solar radiation, temperature, moisture, time of year, presence of pollutants, etc. These factors vary from site to site and should be considered in selecting locations for exposure. Control samples must always be used in weathering tests for comparative analysis. Outdoor exposure for at least two years is required to make evident changes, such as surface degradation without the use of sophisticated analytical equipment.

3.7 Temperature conditions attained with this box may not exactly duplicate those that occur under operational conditions with fluid flow. Dependent on environmental exposure conditions, the cover plate temperatures obtained with this box may be higher or lower than those obtained under operational conditions. Additional testing under stagnation conditions, although not covered by this practice should be conducted.

NOTE 1—Research has shown that exposure outdoors at sites having the combination of high levels of humidity, solar energy, and ambient

temperature can cause more severe degradation of some polymeric cover materials, (for example, microcracking and leaching of UV radiation screening additives) than exposure in arid climates.

NOTE 2—Stagnation conditions are a normal occurrence for solar collectors, for example, during operation when the storage is fully charged; when the collectors are initially installed, before system start-up; or when the system is shut down for maintenance or seasonal considerations such as heating only systems in the summer.

4. Weathering Box Test Fixture

4.1 *Weathering Box Test Fixture*, consisting of a box, rails, a box top, a glazing frame, and adhesive tapes. The weathering box test fixture should be constructed in accordance with Figs. 1-5.

4.1.1 The box and box top should be made in metal that is suitably resistant to corrosion encountered in the exposure environment. A weep hole should be drilled at the lower end of the bottom of the box to provide drainage and to minimize moisture accumulation.

NOTE 3—The box top is intended to protect the edges of the test specimen in contact with the box from reaching excessively high temperatures, to minimize exposure of the adhesive to sunlight, and to minimize moisture penetration into the exposure test fixture.

4.1.2 The box interior shall be a flat black nonselective coating having an absorptance of not less than 0.90 after exposure. Organic absorber coatings should be heated in an oven at 150°C (302°F) for 24 h before the test fixture is assembled. This should minimize outgassing, which results

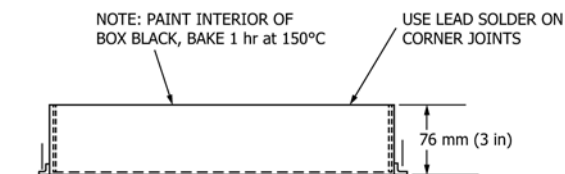
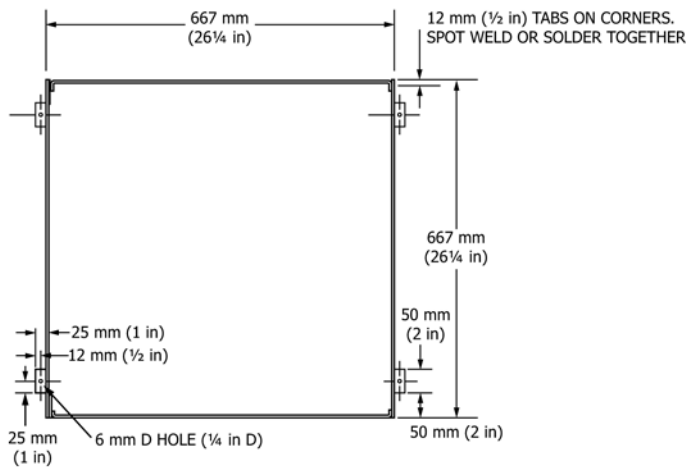

NOTE 1—Material: metal suitably corrosion-resistant for exposure. A typical material would be 24-gage galvanized steel.

NOTE 2—Dimension tolerance ± 1 mm ($\pm 1/16$ in.).

NOTE 3—Box must be watertight when weep hole is covered.

NOTE 4—Paint interior of box black, bake 1 h at 150°C.

NOTE 5—Use lead solder on corner joints.

FIG. 1 Natural Weathering Box—Box

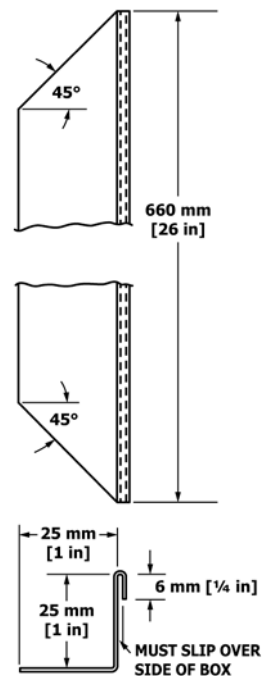

NOTE 1—Make: 4 per box.

NOTE 2—Material: metal suitably corrosion-resistant for exposure. A typical material would be 24-gage galvanized steel.

NOTE 3—Dimension tolerance ± 1 mm ($\pm 1/16$ in.).

FIG. 2 Natural Weathering Box—Rolls

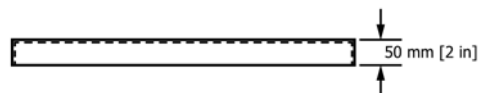
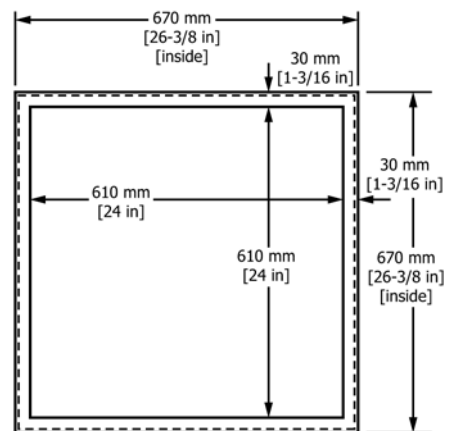

NOTE 1—Make: 1 per box.

NOTE 2—Material: metal suitably corrosion-resistant for exposure. A typical material would be 24-gage galvanized steel.

NOTE 3—Top must fit over box with rails in place.

FIG. 3 Natural Weathering Box—Top

from deterioration of the organic components exposed to elevated temperatures.

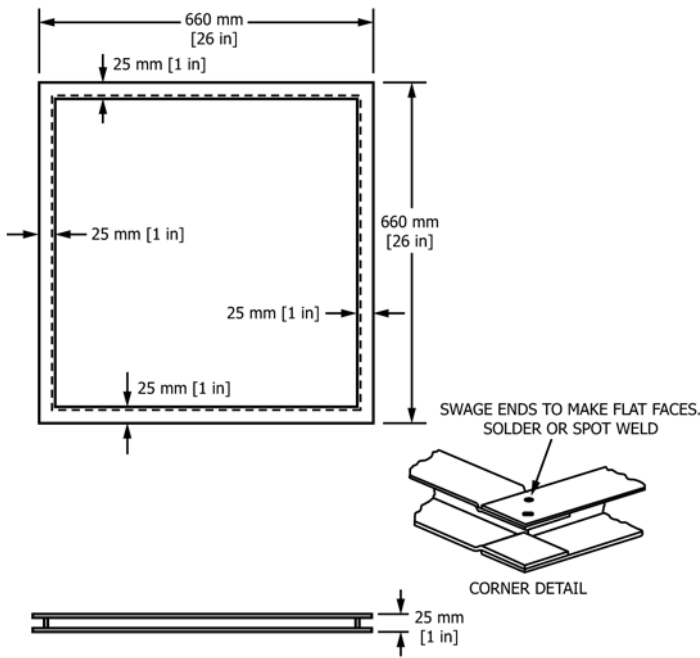

NOTE 1—Make: 1 per box.

NOTE 2—Material: metal suitably corrosion-resistant for exposure. A typical material would be 24-gage galvanized steel.

NOTE 3—Glazing frame must fit into box.

FIG. 4 Natural Weathering Box—Glazing Frame

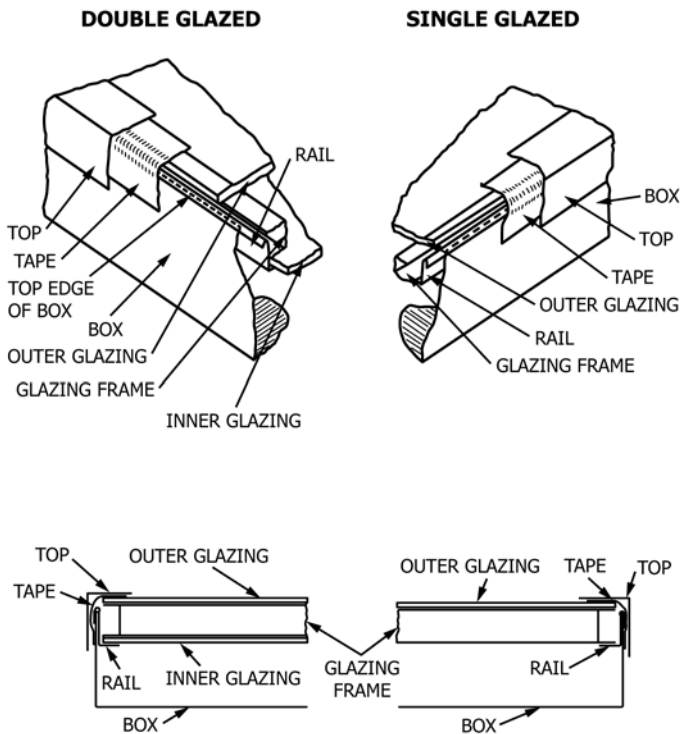

FIG. 5 Natural Weathering Box Assembly—Rigid Glazing

4.1.3 The adhesive tapes should be stable when exposed to moisture and elevated temperatures. They should be compatible with the specific materials from which the box, glazing frame, box top, and cover plate are made.

4.1.4 Organic materials are potential sources for outgassing and should be eliminated from the interior of the weathering box where possible. For example, metallic parts should be cleaned to remove traces of grease or other foreign matter. Other possible sources of outgassing include coatings and sealants. Section 4.1.2 addresses outgassing of absorber coatings.

4.2 Test Specimen:

4.2.1 The test specimen shall be of an adequate size to cover the aperture of the box or glazing frame, and consideration given to dimensional changes due to temperature.

4.2.2 The test specimen identification marks shall not interfere with either the exposure or the subsequent testing.

4.3 Sample Mounting:

4.3.1 Rigid and Semirigid Glazings:

4.3.1.1 Lay test specimens for single cover exposure directly on the glazing frame and place the frame on the rails in the weathering box (see Fig. 5).

4.3.1.2 Lay test specimens for inner cover exposure on a double cover assembly on the rails before the glazing frame is put in place (see Fig. 5).

4.3.1.3 Lay test specimens for outer cover exposure on a double cover assembly on the glazing frame (see Fig. 5).

4.3.2 Films:

4.3.2.1 Place film test specimens on the glazing frame using adhesive transfer tape to hold the test specimens taut. Then place the frame in the box (see Fig. 5) similar to 4.3.1.1, 4.3.1.2, and 4.3.1.3.

4.4 Assembly of Weathering Box:

4.4.1 Slide the various parts of the weathering box test fixture into position. The outer glazing must be roughly flush with the top side of the box. The position of an inner glazing, if used, will be nearest the bottom of the box. If an inner glazing of substantial thickness is used, the frame may protrude above the box edge by an amount equal to the thickness of the glazing.

4.4.2 After assembly, seal the frame and outer glazing in place with an adhesive tape to prevent moisture intrusion. Then place the cover on the box covering the tape (see Fig. 5).

5. Natural Weathering Exposure

5.1 Mount the weathering boxes in a backed condition (using 13-mm (1/2-in.) exterior grade plywood) on weathering racks such as those described in Recommended Practice G7. The racks should be capable of having the angles adjusted and have their axis of rotation on an east-west line.

5.2 Use a variable-angle exposure to maximize solar radiation upon the weathering box. Adjust the racks in accordance with one of the schedules contained in Annex of Practice E881.

5.3 When a number of weathering boxes are exposed simultaneously, mount the boxes side by side with the sides not touching.

5.4 Do not clean the solar collector cover materials during exposure.

6. Report

6.1 The report shall include the following:

6.1.1 Complete identification of the solar collector cover material,

6.1.2 Whether the solar collector cover materials are exposed as a single or double cover configuration and whether the test specimen was the inner or outer cover,

6.1.3 Material used for the absorber coating,

6.1.4 Description of the test specimen attachment and mounting procedures,

6.1.5 Latitude, longitude, altitude, and address of the testing site including a description of the type of climate,

6.1.6 Exposure data,

6.1.7 Climatological data,

6.1.7.1 Radiant exposure (GJ/m^2) measured in the plane of the weathering boxes,

6.1.7.2 Monthly maximum, minimum, and mean temperatures,

6.1.8 Visual inspection of test specimens, noting any obvious changes in appearance should be made at regular scheduled intervals (once per month minimum),

6.1.9 Description of control specimens, and

6.1.10 Any deviation from this practice.

6.2 Other data that are desirable to report, if available, are:

6.2.1 Optional climatological data,

6.2.1.1 Daily maximum, minimum, and mean percent relative humidity,

6.2.1.2 Daily hours of wetness, both dew and rain,

6.2.1.3 Daily total inches of rainfall,

6.2.1.4 Daily maximum and minimum ambient temperature,

6.2.1.5 Daily radiant energy,

6.2.1.6 Wind direction and velocity,

6.2.2 Type of atmosphere, for example, industrial, and level of air pollutants,

6.2.3 Ultraviolet radiation, and

6.2.4 Maximum absorber plate temperature.

7. Keywords

7.1 aging; cover plates; exposure; natural weathering; solar collectors; solar collector cover materials; weathering

ASTM International takes no position respecting the validity of any patent rights asserted in connection with any item mentioned in this standard. Users of this standard are expressly advised that determination of the validity of any such patent rights, and the risk of infringement of such rights, are entirely their own responsibility.

This standard is subject to revision at any time by the responsible technical committee and must be reviewed every five years and if not revised, either reapproved or withdrawn. Your comments are invited either for revision of this standard or for additional standards and should be addressed to ASTM International Headquarters. Your comments will receive careful consideration at a meeting of the responsible technical committee, which you may attend. If you feel that your comments have not received a fair hearing you should make your views known to the ASTM Committee on Standards, at the address shown below.

This standard is copyrighted by ASTM International, 100 Barr Harbor Drive, PO Box C700, West Conshohocken, PA 19428-2959, United States. Individual reprints (single or multiple copies) of this standard may be obtained by contacting ASTM at the above address or at 610-832-9585 (phone), 610-832-9555 (fax), or service@astm.org (e-mail); or through the ASTM website (www.astm.org). Permission rights to photocopy the standard may also be secured from the Copyright Clearance Center, 222 Rosewood Drive, Danvers, MA 01923, Tel: (978) 646-2600; <http://www.copyright.com/>