



# Standard Test Method for Ball Punch Deformation of Metallic Sheet Material<sup>1</sup>

This standard is issued under the fixed designation E643; the number immediately following the designation indicates the year of original adoption or, in the case of revision, the year of last revision. A number in parentheses indicates the year of last reapproval. A superscript epsilon ( $\epsilon$ ) indicates an editorial change since the last revision or reapproval.

## INTRODUCTION

The ball punch deformation test is used for evaluating the ductility of metallic sheet materials. The test involves biaxial stretching of a constrained test specimen. Ideally, no draw-in of flange metal from under the hold-down occurs. The sheet metal test specimen is bulged at a specified rate until the force drops or until either necking or fracture occurs; the test is then terminated. Ball punch (penetrator) movement to drop-in-force or necking or fracture is the test result. It is known that test results may vary with hold-down force, lubrication, and criterion for determining the end point of the test.

### 1. Scope

1.1 This test method covers the procedure for conducting the ball punch deformation test for metallic sheet materials intended for forming applications. The test applies to specimens with thicknesses between 0.008 and 0.080 in. (0.2 and 2.0 mm).

NOTE 1—The ball punch deformation test is intended to replace the Olsen cup test by standardizing many of the test parameters that previously have been left to the discretion of the testing laboratory.

NOTE 2—The modified Erichsen test has been standardized in Europe. The main differences between the ball punch deformation test and the Erichsen test are the diameters of the penetrator and the dies. Erichsen cup heights are given in SI units.

1.2 The values stated in inch-pound units are to be regarded as standard. The values given in parentheses are mathematical conversions to SI units that are provided for information only and are not considered standard.

1.3 *This standard does not purport to address all of the safety concerns, if any, associated with its use. It is the responsibility of the user of this standard to establish appropriate safety and health practices and determine the applicability of regulatory limitations prior to use.*

### 2. Referenced Documents

2.1 *ASTM Standards:*<sup>2</sup>

<sup>1</sup> This test method is under the jurisdiction of ASTM Committee E28 on Mechanical Testing and is the direct responsibility of Subcommittee E28.02 on Ductility and Formability.

Current edition approved May 1, 2015. Published June 2015. Originally published in 1978. Last previous edition approved in 2009 as E643-09. DOI: 10.1520/E0643-15.

<sup>2</sup> For referenced ASTM standards, visit the ASTM website, [www.astm.org](http://www.astm.org), or contact ASTM Customer Service at [service@astm.org](mailto:service@astm.org). For *Annual Book of ASTM Standards* volume information, refer to the standard's Document Summary page on the ASTM website.

[E177 Practice for Use of the Terms Precision and Bias in ASTM Test Methods](#)

[E691 Practice for Conducting an Interlaboratory Study to Determine the Precision of a Test Method](#)

2.2 *National Institute of Standards and Technology Document.*<sup>3</sup>

[NIST Handbook 91 Experimental Statistics](#)

### 3. Terminology

3.1 *Definitions of Terms Specific to This Standard:*

3.1.1 *cup height*, the height of the formed cup at the end point of the test.

### 4. Significance and Use

4.1 The ball punch deformation test is widely used to evaluate and compare the formability of metallic sheet materials. Biaxial stretching is the predominant mode of deformation occurring during the test and, therefore, the results are most often used to rate or compare materials that are to be formed mainly by stretching. However, precise correlations between the cup height as determined by this test and the formability of a sheet material under production conditions have not been established.

4.2 It is recognized that the cup heights for specimens from the same sample may vary with differences in magnitude of hold-down force, lubrication, and method of end point determination. The procedures described in Sections 5, 7.1, and 7.3 will minimize these variations.

### 5. Apparatus

5.1 *Cupping Machines (Fig. 1)*—Any machine used for ball punch deformation tests shall be equipped to hold the specimen

<sup>3</sup> Available from National Institute of Standards and Technology (NIST), 100 Bureau Dr., Stop 1070, Gaithersburg, MD 20899-1070, <http://www.nist.gov>.

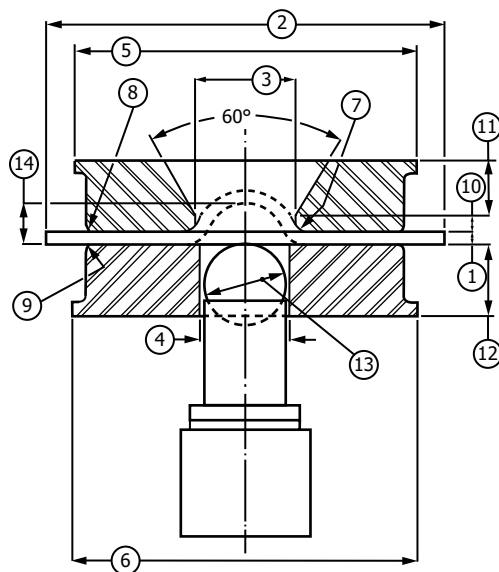

Key	Dimensions	
	in.	mm
(1) Thickness of test piece	full thickness	full thickness
(2) Width of test piece (minimum)	3.5	89
(3) Bore Diameter of top die	See 6.3.	See 6.3.
(4) Bore Diameter of bottom die	1 ± 0.004	25.4 ± 0.1
(5) External diameter of top die (approximate)	3.5	89
(6) External diameter of bottom die (approximate)	3.5	89
(7) Corner radius of interior top die	0.032 ± 0.002	0.81 ± 0.05
(8) Corner radius of exterior top die	0.032	0.81
(9) Depth of bore of top die	0.032	0.81
(10) Depth of bore of top die	0.197 ± 0.010	5.00 ± 0.025
(11) Thickness of top die (minimum)	0.78	20
(12) Thickness of bottom die (minimum)	0.78	20
(13) Diameter of spherical end of penetrator <sup>A</sup>	0.875 ± 0.002	22.2 ± 0.05
(14) Cup Height	Cup Height	Cup Height

<sup>A</sup> "Olsen Ball, 22.22 mm (7/8 in.); "Erichsen" Ball, 20mm.

FIG. 1 Ball Punch Deformation Test Tooling

with a minimum force of 2200 lbf (9800 N). It shall have a spherical-ended penetrator capable of forcing the central portion of the specimen through the die until the end point of the test occurs (see 7.3).

5.1.1 Variation in hold-down force is a source of variation in cup height. For machines not equipped to measure the hold-down force, the magnitude of the force should be established.

5.1.2 The magnitude of the hold-down force shall be such that no appreciable draw-in occurs.

5.1.3 The machine shall be provided with a displacement indicator to measure cup height.

5.2 *Displacement Indicator*—The displacement indicator shall monitor the ball penetrator movement and the scale shall be graduated such that displacement can be measured to within at least ± 0.0025 in. (when using indicators reading in SI units, the displacement shall be measured to within at least ± 0.05 mm).

5.3 *Tooling:*

5.3.1 The penetrator shall be sufficiently rigid so as not to be deformed or to turn or move laterally during the test. Its head shall be spherical and have a diameter of 0.875 ± 0.002 in. (22.2 ± 0.05 mm), and only this spherical portion of the

penetrator shall contact the specimen. The penetrator shall move along the axial centerline of the top and bottom dies. It shall be clean and free from oxide build-up, corrosion, dirt, etc.

5.3.2 The surface of the top die in contact with the test specimen shall be plane and parallel to the surface of the bottom die. Both surfaces shall be clean and free from oxide build-up, corrosion, dirt, etc.

5.3.3 The surface finish of the penetrator and top die in contact with the specimen shall not exceed 160 μin. (0.004 mm) when based on maximum distance peak-to-peak.

5.3.4 The spherical portion of the penetrator shall have a hardness not less than 62 HRC. The working surfaces of the top and bottom dies shall have a hardness of 56 HRC or higher.

6. Test Specimens

6.1 *Number of Tests*—A minimum of three tests shall be performed. When greater precision is required, see Section 9 for determining the number of tests to be performed.

6.2 *Specimen Size*—Specimen blanks may be either circular or rectangular. The minimum width (or diameter) shall be 3.5 in. (89 mm). When evaluating rectangular strip, the cups shall

not be closer than 3.0 in. (76 mm) from center to center, and the center of any cup shall not be within 1.5 in. (38 mm) of the end of the strip.

6.2.1 The minimum specimen width may be 2.5 in. (64 mm) for machines unable to accommodate larger width specimens.

6.3 *Specimen Thickness*—This method applies to thicknesses between 0.008 and 0.080 in. (0.2 and 2.0 mm). The appropriate top dies are shown below. When thicknesses less than 0.020 in. are tested, it is recommended that the top die have self-leveling capability. When thicknesses greater than 0.080 in. are tested, agreement regarding the hold-down pressure necessary to prevent draw-in and the appropriate bore diameter of the top die shall be made between the supplier and the user.

Specimen Thickness, in. (mm)	Bore Diameter of Top Die in. (mm)
0.060 (1.5) or less	1.000 (25.40)
over 0.060 to 0.080 (1.5 to 2.0)	1.125 (28.58)

## 7. Procedure

### 7.1 Lubrication:

7.1.1 The cup height is strongly affected by the choice of lubricant or whether lubrication is employed at all. Studies have shown that variation in lubrication influences the strain distribution and the state of strain in the material being stretched over the punch. The cup height obtained under well lubricated conditions will be significantly greater than that obtained under poorly lubricated conditions.

7.1.1.1 Use a commercially available petroleum jelly as the lubricant.

7.1.1.2 Do not mechanically or chemically alter the specimen surface, which shall be representative of the material as supplied.

7.1.2 Lubricate only the punch. A thin coat of lubricant is sufficient. In order to decrease the possibility of any relative movement (that is, “draw-in”) of the specimen with respect to the die surfaces, do not lubricate the dies or test specimen.

7.1.3 Other systems of lubrication and specimen preparation may be used as agreed upon between the supplier and the user.

### 7.2 Test Speed:

7.2.1 The speed of the penetrator shall be between 0.2 and 1.0 in./min (0.08 and 0.42 mm/s).

7.2.2 Near the end of the test, the speed may be reduced to the lower limit in order to more accurately determine the end point.

### 7.3 End Point of Test:

7.3.1 The preferred method for determining the end point shall be by the drop-in force on the specimen. In general, this indicates the onset of necking in the dome.

7.3.1.1 Some test machines may not be equipped with a force indicator. In this case, the end point shall be either visible necking or fracture of the test specimen in the dome.

7.3.1.2 Do not consider the test results valid for normal reporting when fracture occurs in the hold-down area (base failures).

7.3.1.3 If the drop-in-force method is used and the machine has a pressure switch unit, set the switch at minimum time delay.

7.3.1.4 Report the method used to determine the end point with the test results.

### 7.3.2 Ball Punch Deformation Cup Height:

7.3.2.1 The cup height is the penetrator displacement as measured by the indicator in thousandths of an inch (or hundredths of a millimetre) at the end point of the test.

7.3.2.2 Set the penetrator displacement indicator to read zero at the start of test. The start of test is when the penetrator, under test conditions, makes contact with the specimen.

NOTE 3—The test results may be affected by specimen thinning if the tests are performed on a machine that uses an indicator in contact with the test piece.

## 8. Report

8.1 The report shall include the following:

8.1.1 Identification of the material.

8.1.2 Thickness of the material.

8.1.3 Method of end point determination.

8.1.4 Number of tests.

8.1.5 Type of lubricant, if other than specified.

8.1.6 Average value and range (or standard deviation) of cup heights.

8.1.7 Average of maximum forces (if known).

8.1.8 Method of hold-down—constant or proportional.

8.1.9 Hold-down force (if known).

## 9. Precision and Bias

9.1 The precision of this test method is based on an interlaboratory study of E643, Standard Test Method for Measurement of Ball Punch Deformation of Metallic Sheet Material, conducted in 2008. Each of six laboratories tested five different materials. Every “test result” represents an individual determination. Each laboratory reported three replicate test results for the analyses. Practice E691 was followed

**TABLE 1 Day 1 (thousandths of an in.)**

Material	Average <sup>A</sup>	Repeatability Standard Deviation	Reproducibility Standard Deviation	Repeatability Limit	Reproducibility Limit
	$\bar{x}$	$S_r$	$S_R$	$r$	$R$
A	426.22	2.95	30.98	8.27	86.75
B	371.89	9.50	19.30	26.61	54.04
C	434.33	5.73	24.04	16.03	67.30
D	408.72	8.09	16.73	22.65	46.86
E	581.00	10.60	25.30	29.68	70.83

<sup>A</sup>The average of the laboratories' calculated averages.

**TABLE 2 Day 2 (thousandths of an in.)**

Material	Average <sup>A</sup>	Repeatability Standard Deviation	Reproducibility Standard Deviation	Repeatability Limit	Reproducibility Limit
	$\bar{x}$	$S_r$	$S_R$	$r$	$R$
A	426.61	2.37	28.79	6.63	80.61
B	370.28	5.43	25.38	15.19	71.05
C	437.61	3.99	22.50	11.16	63.00
D	408.39	4.05	21.14	11.34	59.19
E	579.83	9.40	22.78	26.31	63.79

<sup>A</sup>The average of the laboratories' calculated averages.

**TABLE 3 Day 3 (thousandths of an in.)**

Material	Average <sup>A</sup>	Repeatability Standard Deviation	Reproducibility Standard Deviation	Repeatability Limit	Reproducibility Limit
	$\bar{x}$	$S_r$	$S_R$	$r$	$R$
A	425.89	2.86	32.05	8.00	89.74
B	376.44	8.83	17.55	24.74	49.15
C	435.94	3.77	22.41	10.56	62.75
D	408.06	7.62	17.67	21.33	49.47
E	579.44	3.82	22.78	10.70	63.79

<sup>A</sup>The average of the laboratories' calculated averages.

for the design and analysis of the data; the details are given in ASTM Research Report No. E28-1041.<sup>4</sup>

9.1.1 *Repeatability limit (r)*—Two test results obtained within one laboratory shall be judged not equivalent if they differ by more than the “*r*” value for that material; “*r*” is the interval representing the critical difference between two test results for the same material, obtained by the same operator using the same equipment on the same day in the same laboratory.

9.1.1.1 Repeatability limits are listed in [Table 1](#), [Table 2](#), and [Table 3](#).

9.1.2 *Reproducibility limit (R)*—Two test results shall be judged not equivalent if they differ by more than the “*R*” value for that material; “*R*” is the interval representing the critical difference between two test results for the same material, obtained by different operators using different equipment in different laboratories.

<sup>4</sup> Supporting data have been filed at ASTM International Headquarters and may be obtained by requesting Research Report RR:E28-1041.

9.1.2.1 Reproducibility limits are listed in [Table 1](#), [Table 2](#), and [Table 3](#).

9.1.3 The above terms (repeatability limit and reproducibility limit) are used as specified in Practice [E177](#).

9.1.4 Any judgment in accordance with statements [9.1.1](#) and [9.1.2](#) would have an approximate 95% probability of being correct.

9.2 *Bias*—At the time of the study, there was no accepted reference material suitable for determining the bias for this test method, therefore no statement on bias is being made.

9.3 The precision statement was determined through statistical examination of 270 results, from six laboratories, on five materials. The materials were described as the following:  
 Material A: 0.021 in. Cold rolled steel (uncoated)  
 Material B: 0.034 in. Hot-dip galvanized steel  
 Material C: 0.036 in. Hot-dip galvanized steel  
 Material D: 0.038 in. Cold rolled steel (uncoated)  
 Material E: 0.079 in. Hot-dip galvanized steel

*ASTM International takes no position respecting the validity of any patent rights asserted in connection with any item mentioned in this standard. Users of this standard are expressly advised that determination of the validity of any such patent rights, and the risk of infringement of such rights, are entirely their own responsibility.*

*This standard is subject to revision at any time by the responsible technical committee and must be reviewed every five years and if not revised, either reapproved or withdrawn. Your comments are invited either for revision of this standard or for additional standards and should be addressed to ASTM International Headquarters. Your comments will receive careful consideration at a meeting of the responsible technical committee, which you may attend. If you feel that your comments have not received a fair hearing you should make your views known to the ASTM Committee on Standards, at the address shown below.*

*This standard is copyrighted by ASTM International, 100 Barr Harbor Drive, PO Box C700, West Conshohocken, PA 19428-2959, United States. Individual reprints (single or multiple copies) of this standard may be obtained by contacting ASTM at the above address or at 610-832-9585 (phone), 610-832-9555 (fax), or service@astm.org (e-mail); or through the ASTM website (www.astm.org). Permission rights to photocopy the standard may also be secured from the Copyright Clearance Center, 222 Rosewood Drive, Danvers, MA 01923, Tel: (978) 646-2600; http://www.copyright.com/*