



Standard Practice for Sampling of Zinc and Zinc Alloys by Spark Atomic Emission Spectrometry¹

This standard is issued under the fixed designation E634; the number immediately following the designation indicates the year of original adoption or, in the case of revision, the year of last revision. A number in parentheses indicates the year of last reappraisal. A superscript epsilon (ϵ) indicates an editorial change since the last revision or reappraisal.

1. Scope

1.1 This practice covers the sampling of zinc and zinc alloys to obtain a sample suitable for quantitative spark atomic emission spectrochemical analysis. Included are procedures for obtaining representative samples from molten metal, from fabricated or cast products that can be melted, and from other forms that cannot be melted.

1.2 The values stated in SI units are to be regarded as standard. The values given in parentheses are for information only.

1.3 *This standard does not purport to address all of the safety concerns, if any, associated with its use. It is the responsibility of the user of this standard to establish appropriate safety and health practices and determine the applicability of regulatory limitations prior to use.*

2. Summary of Practice

2.1 Molten metal representative of the furnace melt is poured into a mold to produce a chill-cast sample. The sample, which must represent the average composition, is machined to a specified shape to produce an acceptable surface for excitation.

2.2 Fabricated or cast products are remelted and cast into molds or are excited directly without remelting.

3. Significance and Use

3.1 This practice, used in conjunction with an appropriate quantitative spark atomic emission spectrochemical method, is suitable for use in manufacturing control, material or product acceptance, and development and research.

4. Apparatus

4.1 *Ladle*, of steel, designed to hold sufficient molten metal to completely fill the sample mold, with a handle of sufficient length to reach into a furnace, trough, pot, or crucible.

¹ This practice is under the jurisdiction of ASTM Committee E01 on Analytical Chemistry for Metals, Ores, and Related Materials and is the direct responsibility of Subcommittee E01.05 on Cu, Pb, Zn, Cd, Sn, Be, their Alloys, and Related Metals.

Current edition approved April 1, 2012. Published May 2012. Originally approved in 1978. Last previous edition approved in 2005 as E634 – 05. DOI: 10.1520/E0634-12.

NOTE 1—Pure zinc metal (Special High Grade) is sampled using a ceramic or graphite ladle, as the solubility of iron in Special High Grade Zinc is sufficient to cause a measurable contamination.

4.2 *Sample Molds*, designed to produce homogeneous chill-cast specimens having smooth surfaces, free from surface pockets and pores. The specimens shall be representative (in the region to be excited) of the product metal. The samples shall have a spectrochemical response similar to the standards used in preparing the analytical curves. This is ensured by casting standards and specimens in the same manner. Also, the specimens shall have a repeatability of measurement for major elements from excitation-to-excitation with a relative error of no more than 2 %. Several types of molds have been found acceptable.

4.2.1 *Type A, Pin Mold (Fig. 1)*—This mold produces two diagonally cast pins with sprues at the top of the specimens. The mold dimensions are such as to produce pins approximately 100 mm (3.9 in.) in length by 11 mm (0.4 in.) in diameter. The mold is made of steel or cast iron and weighs approximately 4.5 to 5.5 kg (10 to 12 lb). Pin specimens have been found to be very homogeneous. If properly prepared, these specimens provide very reliable results with only one burn. However, pin specimens must be reshaped for each additional burn.

4.2.2 *Type B, Book Mold (Fig. 2)*—This mold produces a vertically cast disk with a sprue on the edge of the specimen. The mold dimensions are such as to produce a disk of approximately 64 mm (2.5 in.) in diameter by 6 to 8 mm (0.2 to 0.3 in.) in thickness. A circular central recess, 15 to 25 mm (0.6 to 1.0 in.) in diameter, on one side of the specimen facilitates machining of that side in preparation for excitation. It also promotes more uniform freezing of the raised peripheral area. The mold is made of steel or cast iron and weighs approximately 2 to 3 kg (4 to 7 lb). This mold works well for high purity zinc grades, but with alloys may cause segregation due to solidification phenomena. Specimens should be excited only in the areas indicated in Fig. 3, and it may be necessary to make several burns and report an average. The user is strongly cautioned to thoroughly investigate specimen homogeneity for each alloy system to be analyzed.

4.2.3 *Type C, Center Pour Mold (Fig. 4)*—This mold produces a horizontally cast disk with a sprue over the center on the back side. The mold dimensions are such as to produce

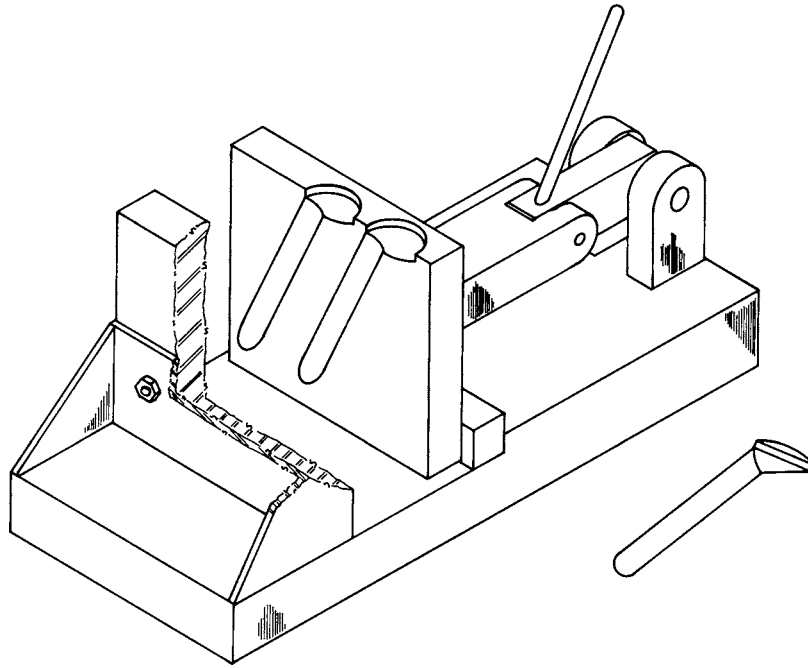

FIG. 1 Type A Mold and Specimen

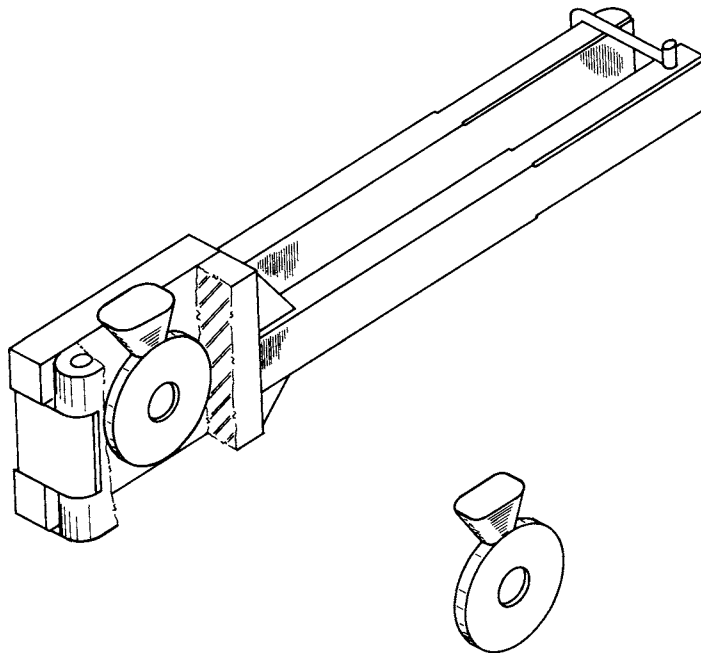

FIG. 2 Type B Mold and Specimen

a disk approximately 64 mm (2.5 in.) in diameter by 8 mm (0.3 in.) in thickness. A circular central recess, 10 to 20 mm (0.4 to 0.8 in.) in diameter, on one side of the specimen facilitates machining of that side in preparation for excitation. It also promotes more uniform freezing of the raised peripheral area, but the corresponding raised portion of the mold shall not be so large as to restrict the throat for the sprue. A slight taper, 1 to 2 deg, on the hinged portion of the mold facilitates opening when a specimen has been cast. The mold is made of steel or cast iron and weighs approximately 3.5 to 4.5 kg (8 to 10 lb).

The advantage of this mold is that the specimen obtained may be excited around the entire annular area. However, as with the vertically cast disk specimens, although not as severe, segregation can be a problem. Therefore, it may be necessary to make several burns and report an average.

4.2.4 *Other Molds*—Molds of different types, materials, and dimensions may be used provided that the uniformity of the specimens obtained is comparable to the uniformity of specimens obtained from Type A, B, or C molds. Further, the

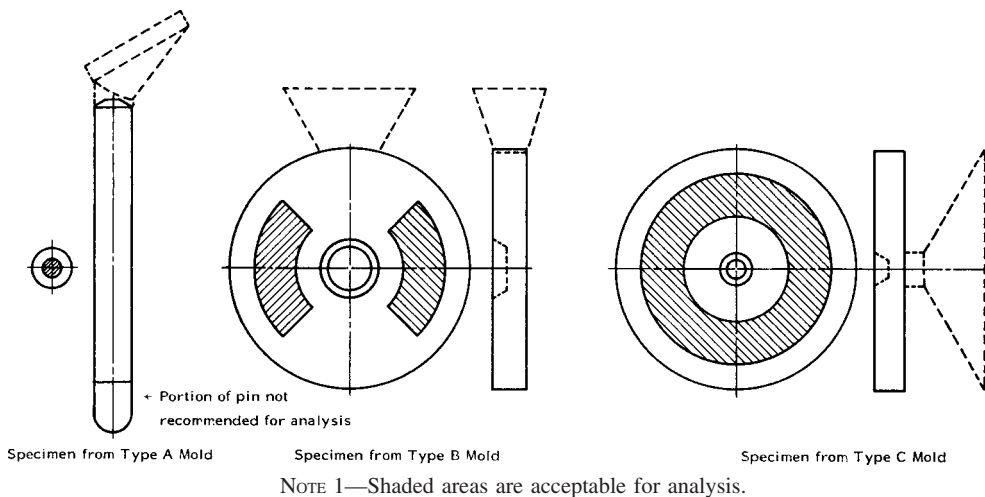

FIG. 3 Specimens from Type A, B, and C Molds

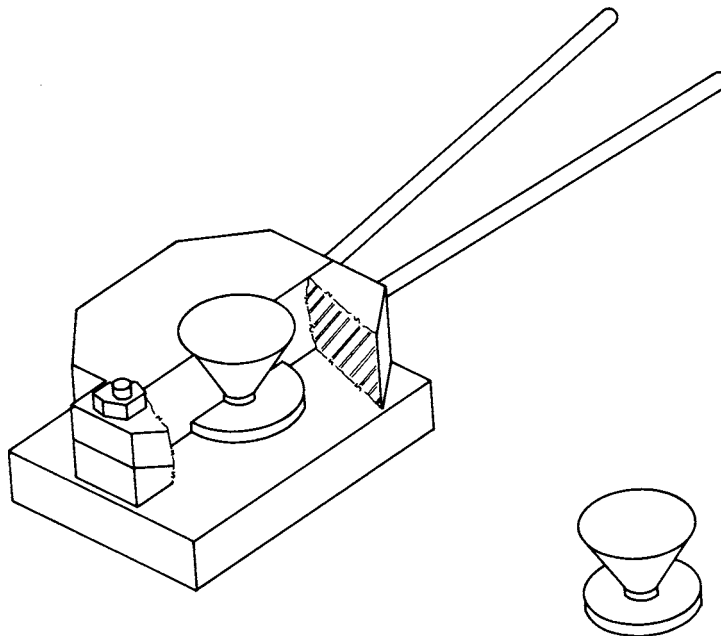

FIG. 4 Type C Mold and Specimen

specimens shall have a spectrochemical response similar to the standards used for preparing the analytical curves.

4.3 *Lathe or Milling Machine*, capable of machining a smooth flat surface.

NOTE 2—When using pin specimens, reproducibility of the exact pin shape is very important. To maintain the integrity of the pin shapes it may be necessary to equip a micrometer cross-fed lathe with a special pin-shaping tool.

4.4 *Cutting Tools*—Either alloy steel or cemented carbide is recommended.

5. Sampling

5.1 *Molten Metal*—When molten metal is sampled, the temperature shall be well above the point at which any solid

phase can be present. Using a clean ladle, push any dross away from the sampling area. Then dip the ladle sideways into the clear area, well below the surface, and stir momentarily. Turn the ladle upright and quickly withdraw. Heating the ladle prevents metal freezing, while obtaining metal well beneath the surface minimizes the danger of inclusion of oxide. Unless the mold is already hot, cast and discard a preliminary specimen. Remove any excess metal from the ladle, dip it into the molten metal as before, and fill the mold using an even rate of pour so as to allow for the escape of air. Do not dump the metal into the mold. Avoid overfilling the sprue or the mold may be difficult to open. Allow the metal to freeze without jarring. The cast surfaces of the specimen, upon removal from the mold, shall be free from shrinkage, inclusions, cracks, or roughness.

NOTE 3—A change in the temperature profile of the mold, caused by a significant change in the sampling rate, may result in different chill-cast characteristics and poor repeatability. Therefore, it is recommended that the sampling schedule be considered when an analysis program is being developed. Also, experience has shown that pin specimens are much less sensitive than disk samples to temperature profile changes in the mold.

5.2 Fabricated and Cast Products—When the metal is in the wrought or cast form and a destructive test is practical, remelt a representative portion of the metal at a temperature well above the liquidus line on the phase diagram of the metal. The sample is placed in a graphite or other inert crucible and heated in a laboratory electric furnace. The melt is then cast in the mold as outlined in 5.1. If the sample is in the form of thin sheet, turnings, or other finely divided material, remove any coatings or grease with an appropriate solvent and press into a briquet before melting. Details of briquet size and formation are not critical to the successful preparation of a melt. It is imperative that the specimen and the standards used in preparing the analytical curves undergo the same sampling procedure, that is, remelting, to ensure valid analyses. However, when possible, it is recommended that analytical methods involving dissolution of the metal be used in preference to the remelting of samples.

6. Preparation of Specimens

6.1 Chill-Cast Pins from Type A Mold—Cut off the sprues from the pins and machine the sprue ends of both pins to the same shape. Each time the pins are reshaped, about 3 mm (0.1 in.) of metal should be removed from the end of the pins. Then make a second cut to produce a surface at an angle of about 60 deg to the axis of the pin. Continue this cut until the flat end of the pin measures exactly 3 mm (0.1 in.) in diameter. The completed pin tip is a truncated cone with a 120-deg apex angle and a 3-mm (0.1-in.) diameter (Fig. 3). The machined surface shall be smooth and free from scuffs, pits, or inclusions. The ideal surface is neither polished nor visibly grooved, but should show a very fine tool pattern. More specifically, the ideal surface may be defined as approximately a 1.6 by 10⁻³-mm (63- μ m.) standard machine finish. A surface much finer or coarser may result in an analytical difference. Further, it is important that both specimens and standards have the same machine finish. Pin specimens have been found to be very homogeneous and can be excited over the entire length of the pin. However, it is recommended that the lower 13 mm (0.5

in.) of the pin specimen (Fig. 3) not be excited because of potential solidification effects.

6.2 Chill-Cast Disk from Type B or C Molds—Cut off the sprue and machine the raised peripheral area surrounding the recess to a depth of 1 to 1.5 mm (0.04 to 0.06 in.) below the original surface. This depth is important because it corresponds to the composition on the phase diagram which represents the average composition of the entire disk and, in turn, the actual composition of the melt. Any other depth may result in an invalid analysis. The machined surface shall be smooth, and free from scuffs, pits, or inclusions. The ideal surface is neither polished nor visibly grooved, but should show a very fine tool pattern. The ideal surface may be defined as approximately a 1.6 by 10⁻³-mm (63- μ m.) standard machine finish. A surface much finer or much coarser may result in an analytical difference. It is also important that both specimens and standards have the same machine finish. A type B disk may be excited only in certain areas (Fig. 3), while a Type C disk may be excited around the entire annular area. For both types, the outer 5 mm (0.2 in.) to the edge and the inner region up to about a 12-mm (0.48-in.) radius should not be excited (Fig. 3).

6.3 Chill-Cast Specimens from Other Acceptable Molds—Since a mold of different dimensions may result in a different freezing pattern, each type of mold shall be evaluated to determine the proper area and depth to machine the specimen to represent the true composition of the melt.

6.4 Direct Excitation Without Casting a Specimen—If the procedure outlined in Section 5 cannot be followed, only approximate analyses can be made. The specimen shall be massive enough to prevent undue heating and shall have a flat surface suitable for excitation. Further, standards having a similar spectrochemical response shall be available. On sheet or plate specimens, machine off about 0.8 mm (0.03 in.) or one-fourth of the thickness, whichever is smaller. On thicker specimens, machine at least 1.3 mm (0.05 in.) below the original surface. Choose the location, depth, and number of areas to be analyzed to provide a representative analysis of the product.

7. Keywords

7.1 optical emission; sampling; spark atomic emission; spectrochemical analysis; zinc and zinc alloys

ASTM International takes no position respecting the validity of any patent rights asserted in connection with any item mentioned in this standard. Users of this standard are expressly advised that determination of the validity of any such patent rights, and the risk of infringement of such rights, are entirely their own responsibility.

This standard is subject to revision at any time by the responsible technical committee and must be reviewed every five years and if not revised, either reapproved or withdrawn. Your comments are invited either for revision of this standard or for additional standards and should be addressed to ASTM International Headquarters. Your comments will receive careful consideration at a meeting of the responsible technical committee, which you may attend. If you feel that your comments have not received a fair hearing you should make your views known to the ASTM Committee on Standards, at the address shown below.

This standard is copyrighted by ASTM International, 100 Barr Harbor Drive, PO Box C700, West Conshohocken, PA 19428-2959, United States. Individual reprints (single or multiple copies) of this standard may be obtained by contacting ASTM at the above address or at 610-832-9585 (phone), 610-832-9555 (fax), or service@astm.org (e-mail); or through the ASTM website (www.astm.org). Permission rights to photocopy the standard may also be secured from the ASTM website (www.astm.org/COPYRIGHT/).